

**RETAINED PROTEIN DOMAINS**  
reading frame unclear



**SUPPORTING READ COUNT**

Split reads = 3994  
Discordant mates = 77

- translocation
- duplication
- deletion
- inversion

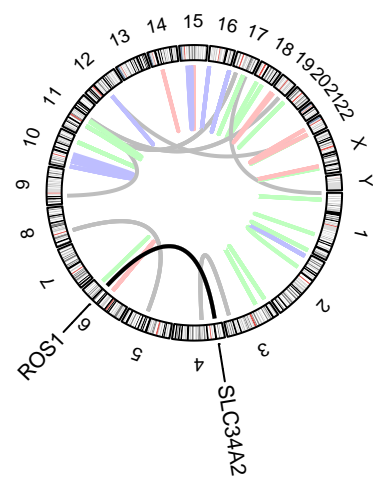
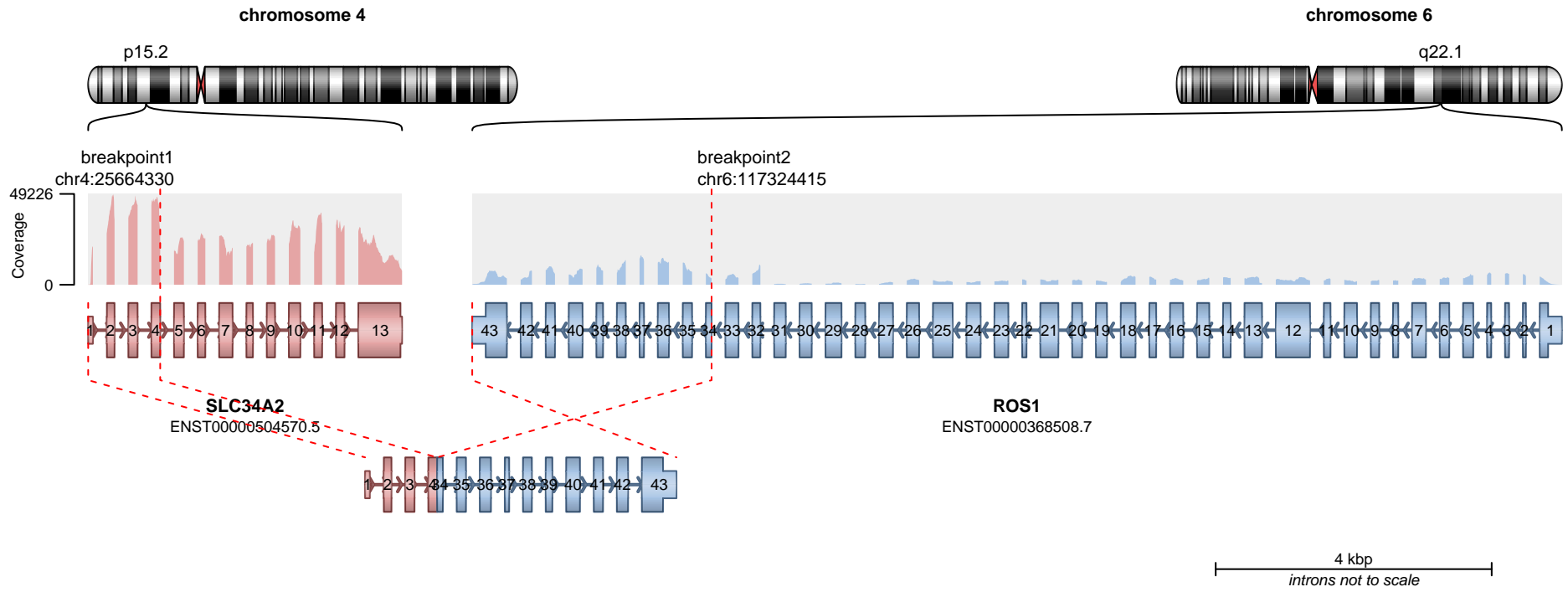

**RETAINED PROTEIN DOMAINS**  
reading frame unclear



**SUPPORTING READ COUNT**

Split reads = 272  
Discordant mates = 16

- translocation
- duplication
- deletion
- inversion

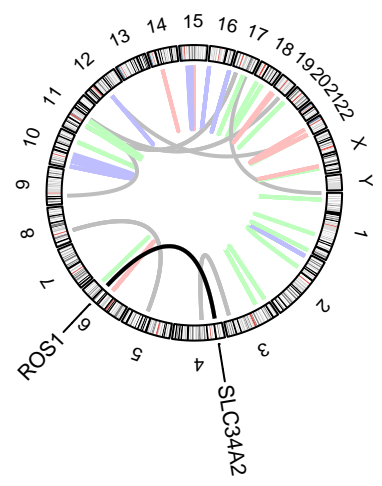
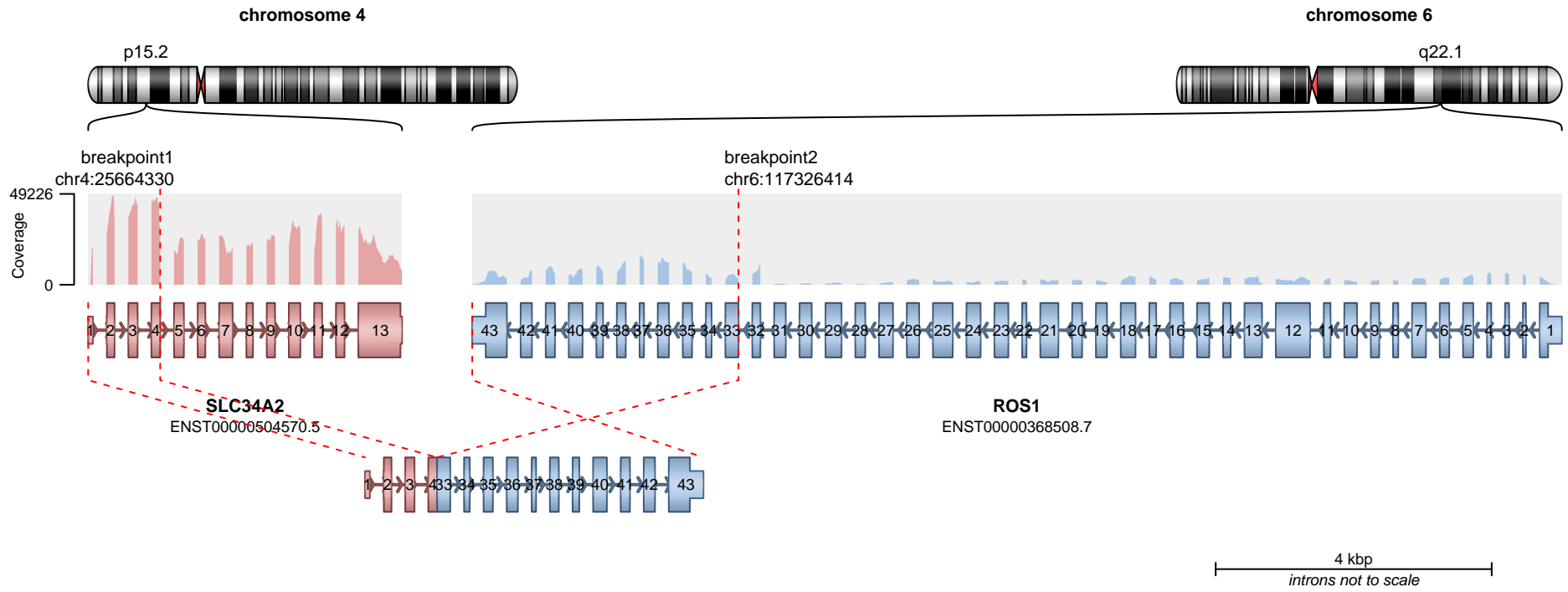

**RETAINED PROTEIN DOMAINS**  
reading frame unclear



**SUPPORTING READ COUNT**

Split reads = 61  
Discordant mates = 16

- translocation
- duplication
- deletion
- inversion

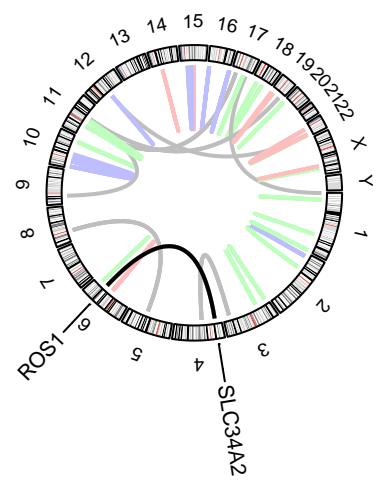
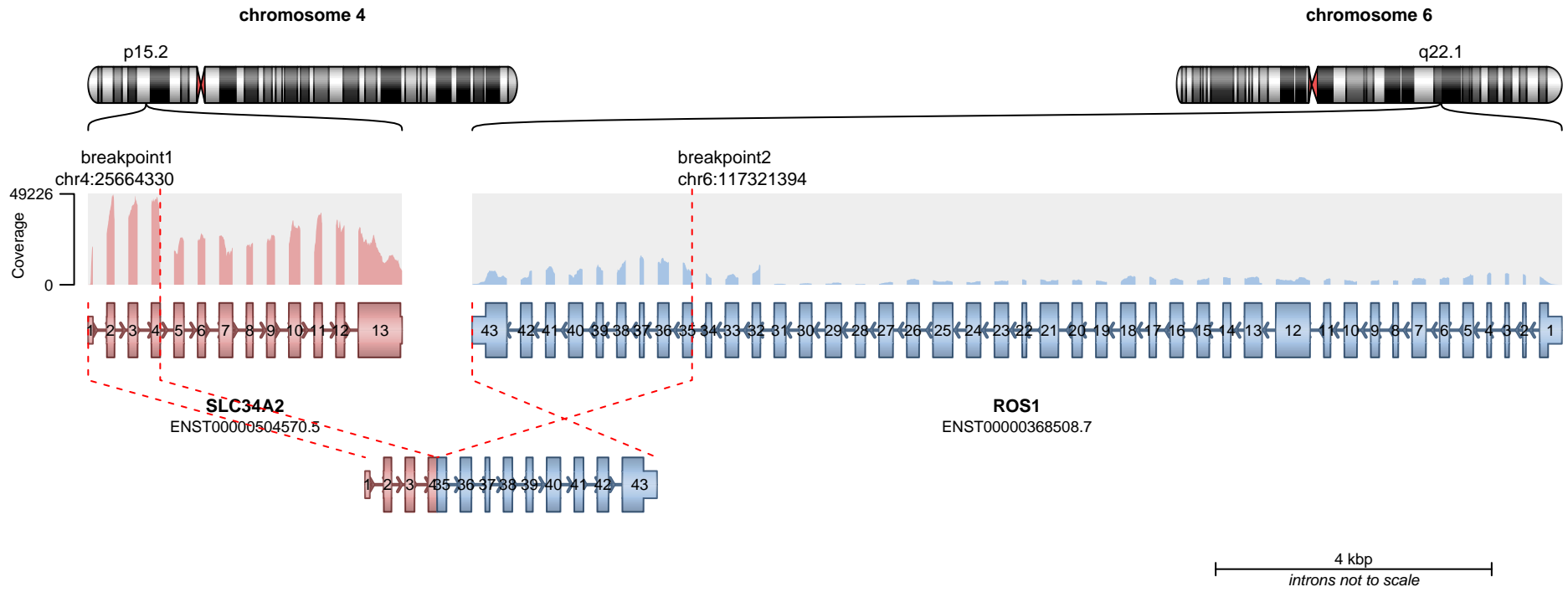

**RETAINED PROTEIN DOMAINS**  
reading frame unclear

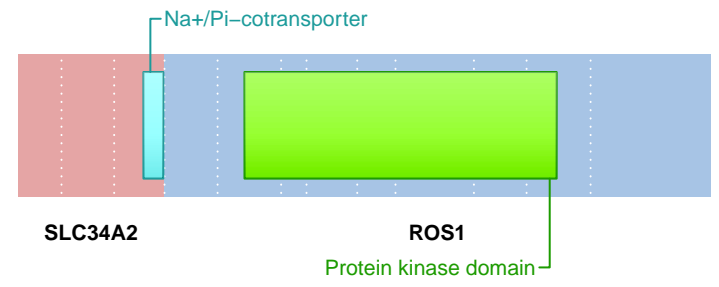

**SUPPORTING READ COUNT**

Split reads = 21  
Discordant mates = 4

- translocation
- duplication
- deletion
- inversion

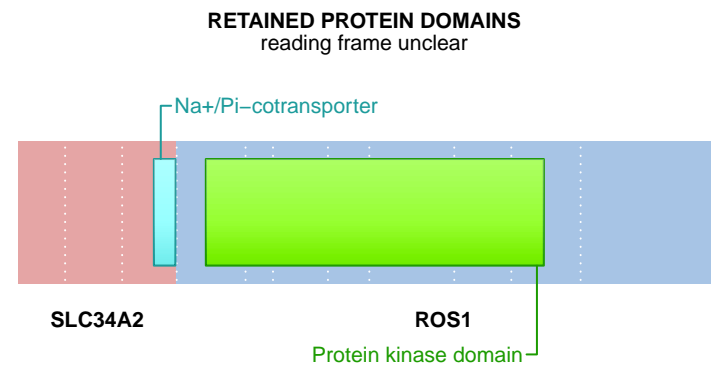
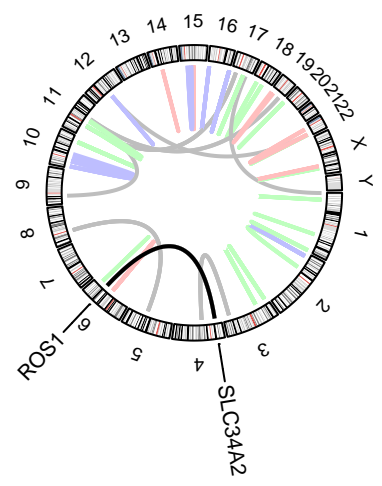
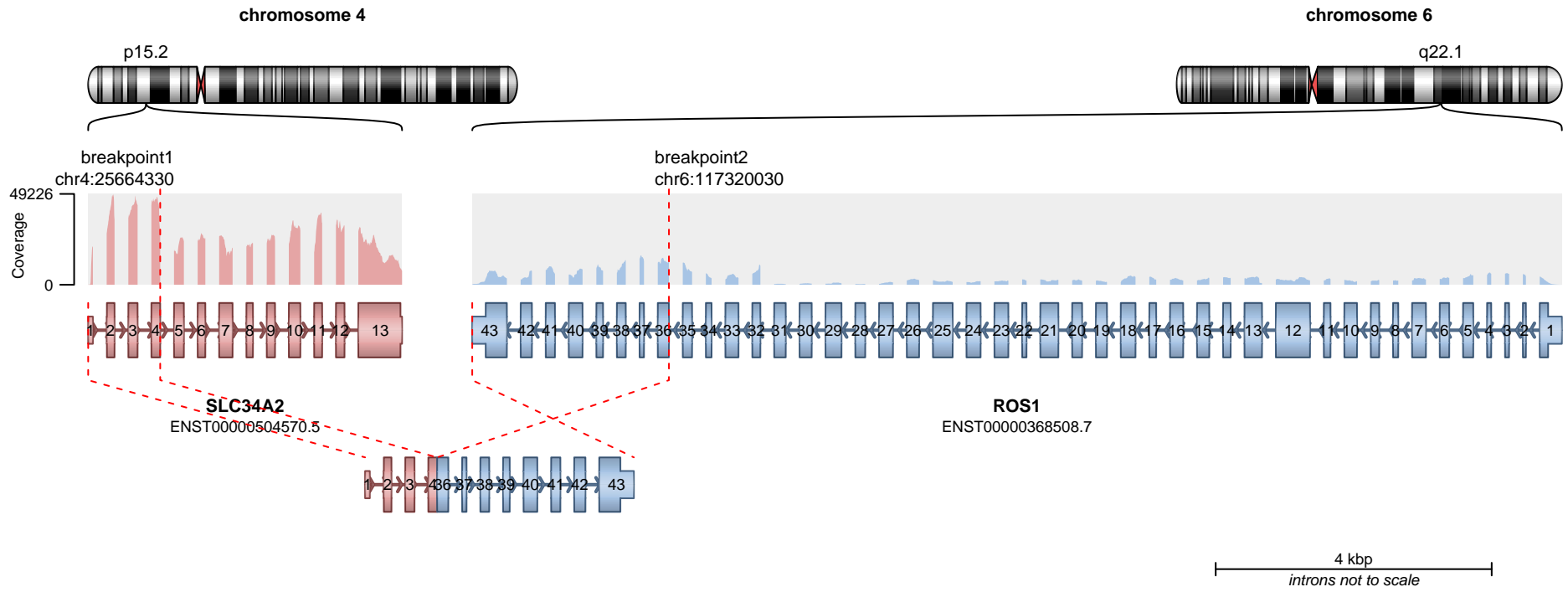

**SUPPORTING READ COUNT**

Split reads = 5  
Discordant mates = 1

— translocation — deletion  
— duplication — inversion

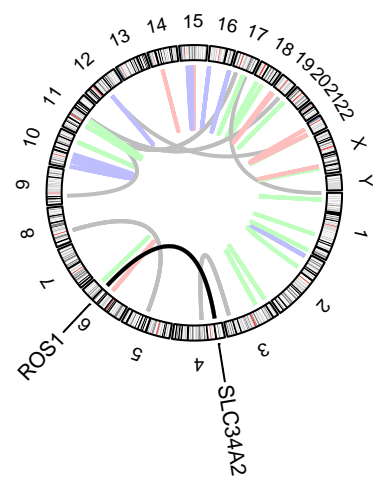
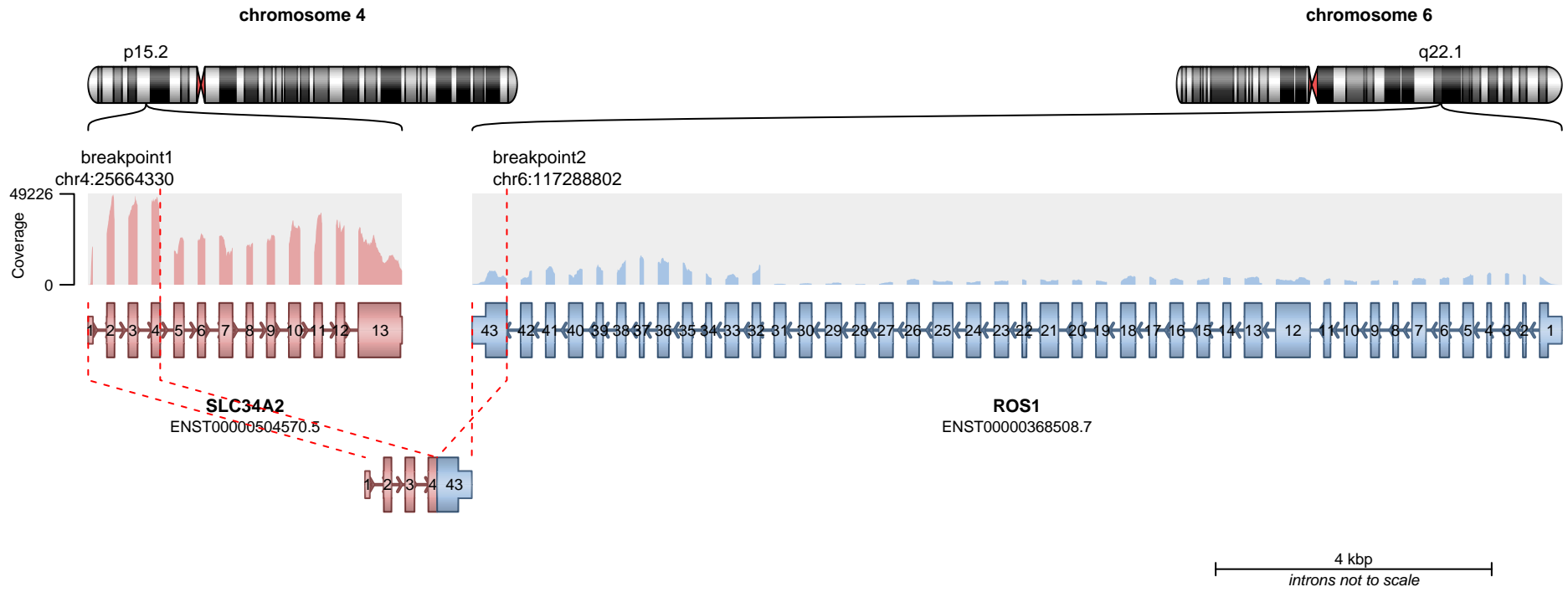

**RETAINED PROTEIN DOMAINS**  
reading frame unclear

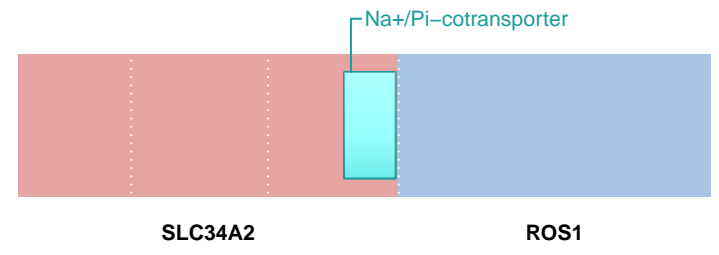

**SUPPORTING READ COUNT**

Split reads = 3  
Discordant mates = 0

- translocation
- duplication
- deletion
- inversion

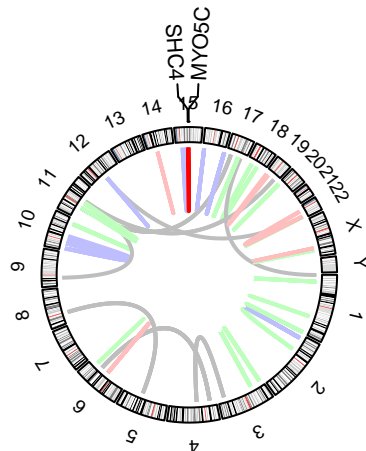
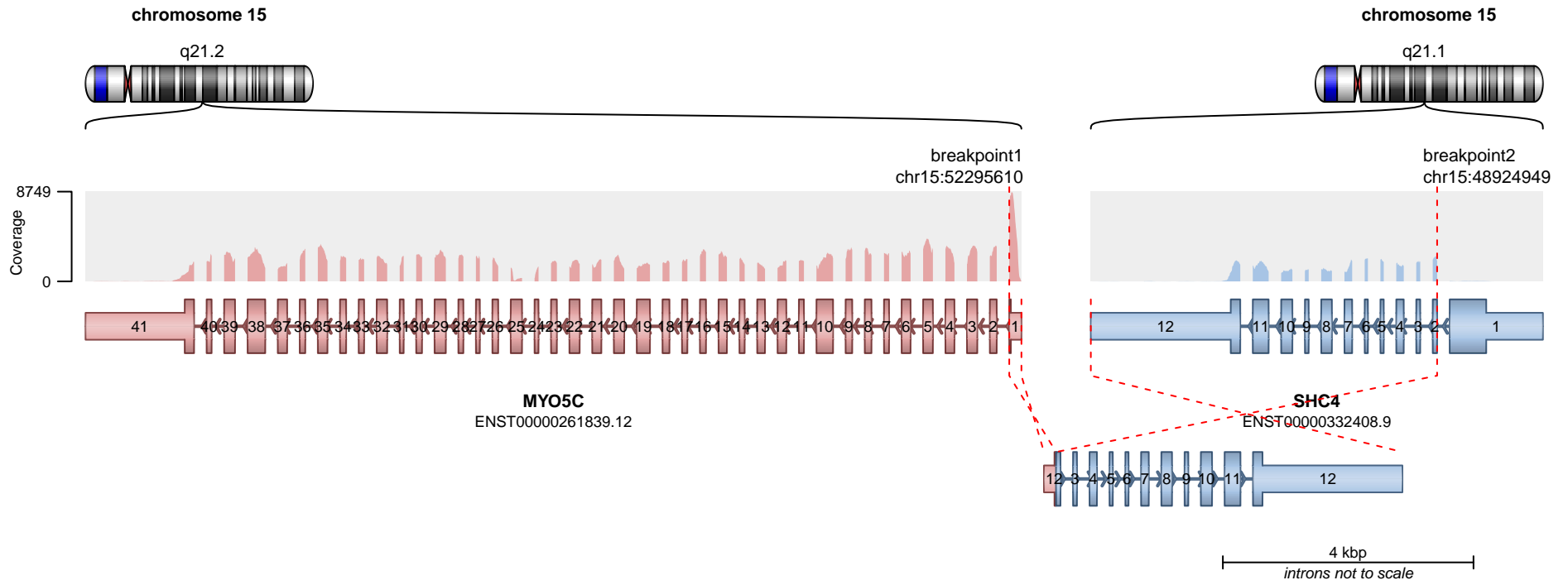

**RETAINED PROTEIN DOMAINS**  
reading frame unclear

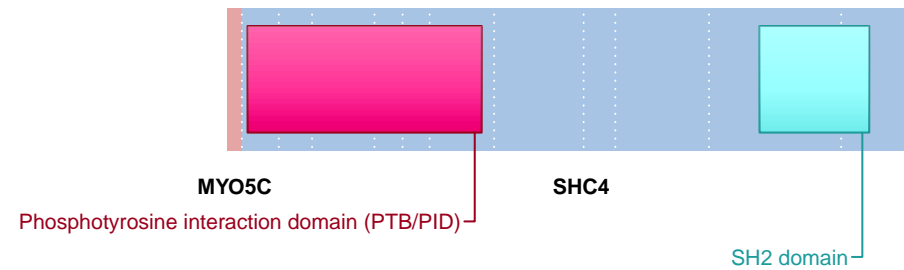

**SUPPORTING READ COUNT**

Split reads = 1099  
Discordant mates = 22

- translocation
- duplication
- deletion
- inversion

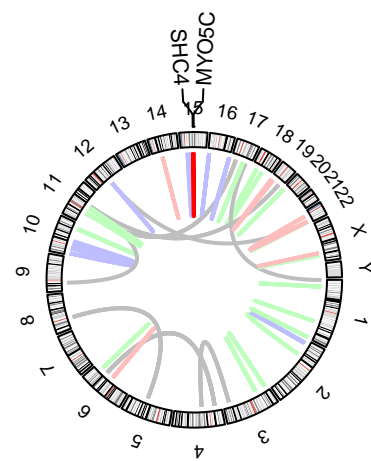
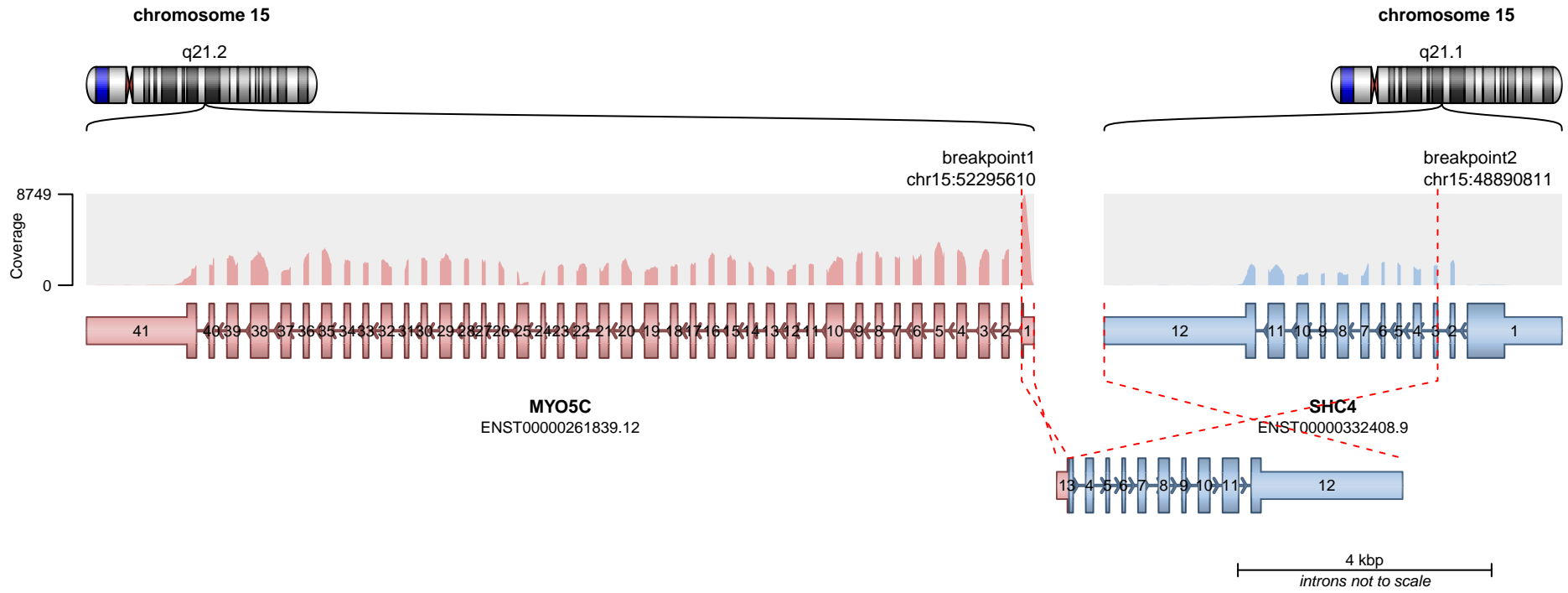

**RETAINED PROTEIN DOMAINS**  
reading frame unclear

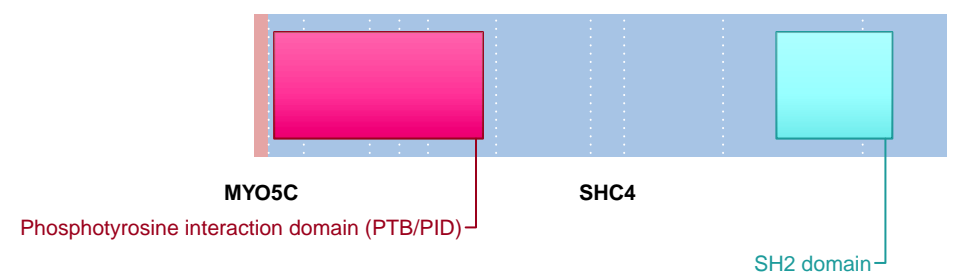

**SUPPORTING READ COUNT**

Split reads = 33  
Discordant mates = 11

- translocation
- duplication
- deletion
- inversion

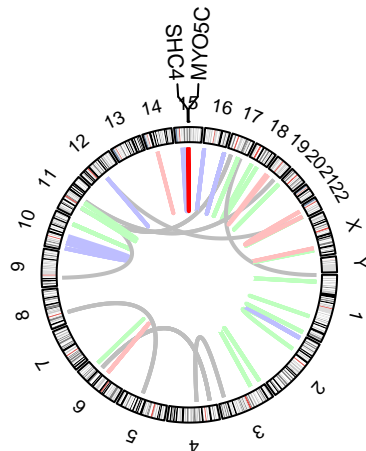
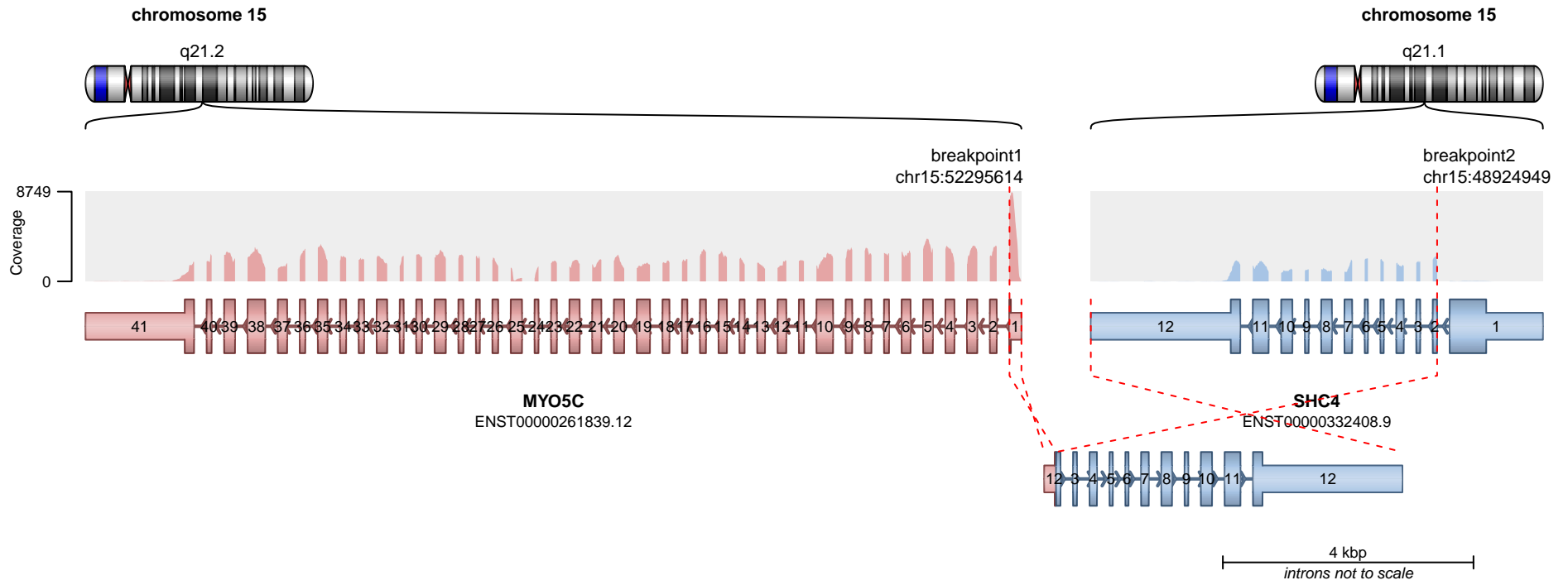

**RETAINED PROTEIN DOMAINS**  
reading frame unclear

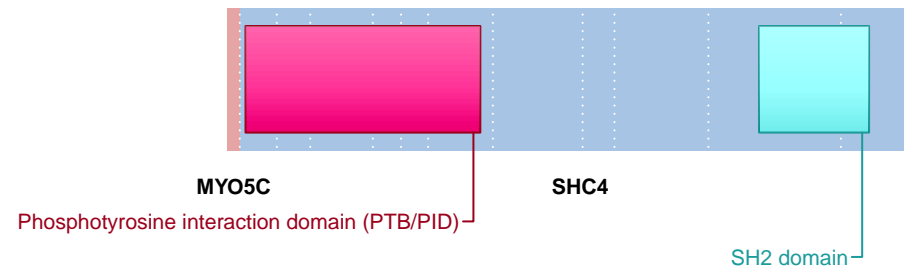

**SUPPORTING READ COUNT**

Split reads = 5  
Discordant mates = 22

- translocation
- duplication
- deletion
- inversion

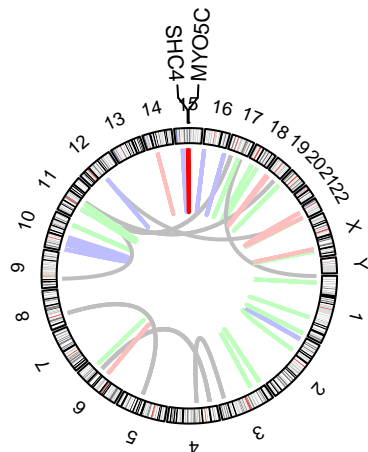
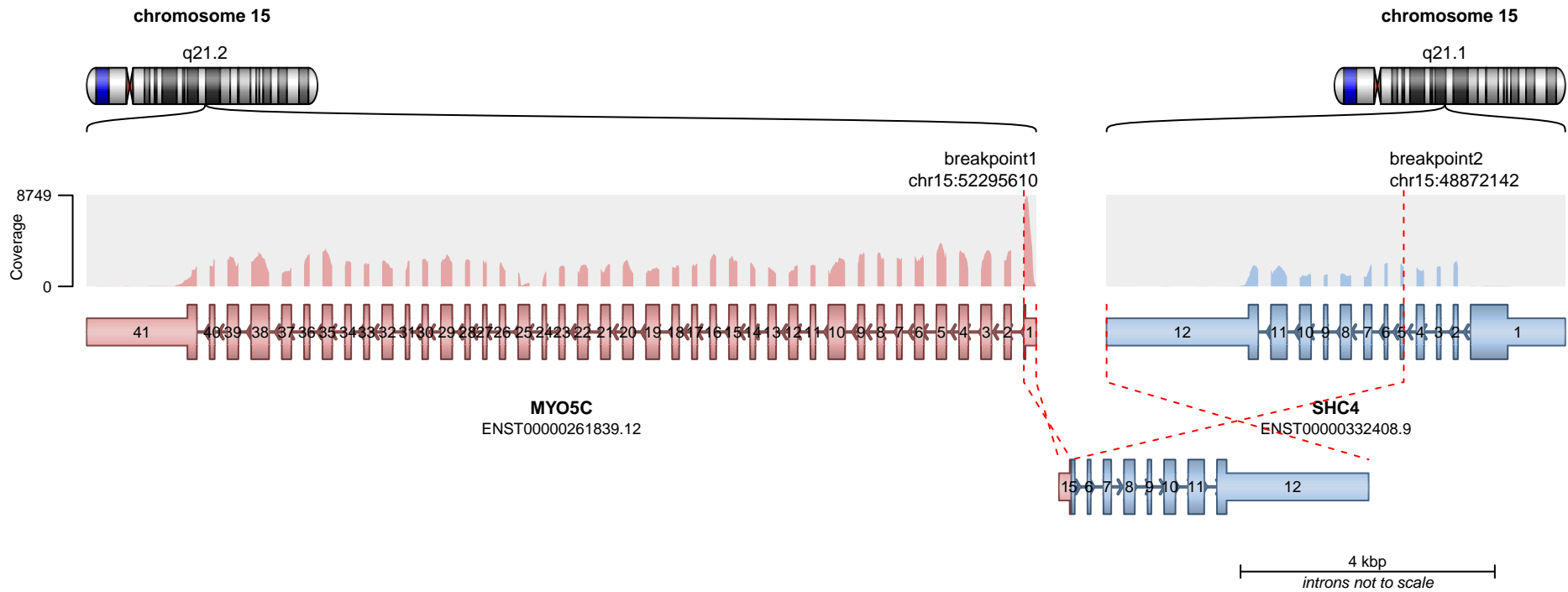

**RETAINED PROTEIN DOMAINS**  
reading frame unclear

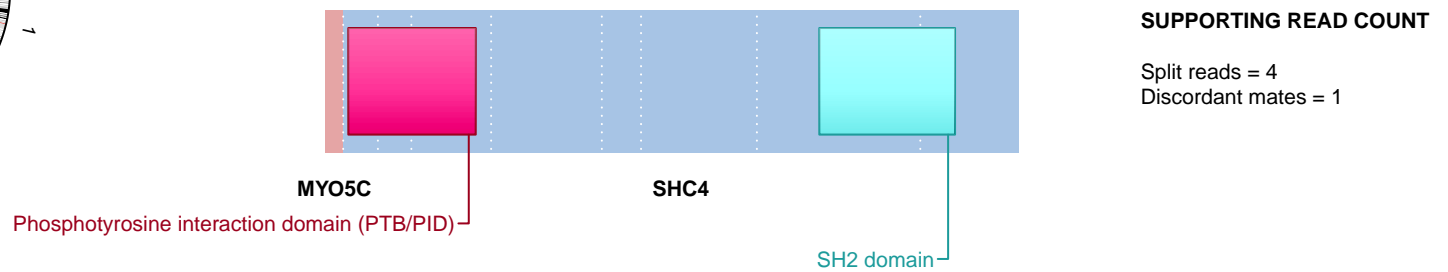

- translocation
- duplication
- deletion
- inversion

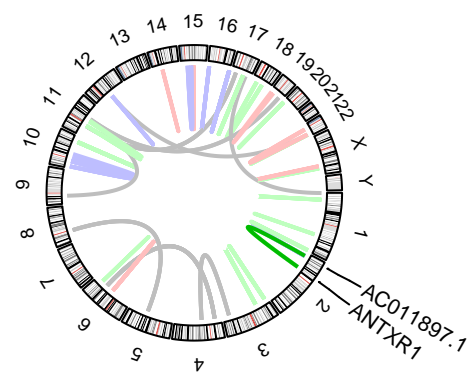
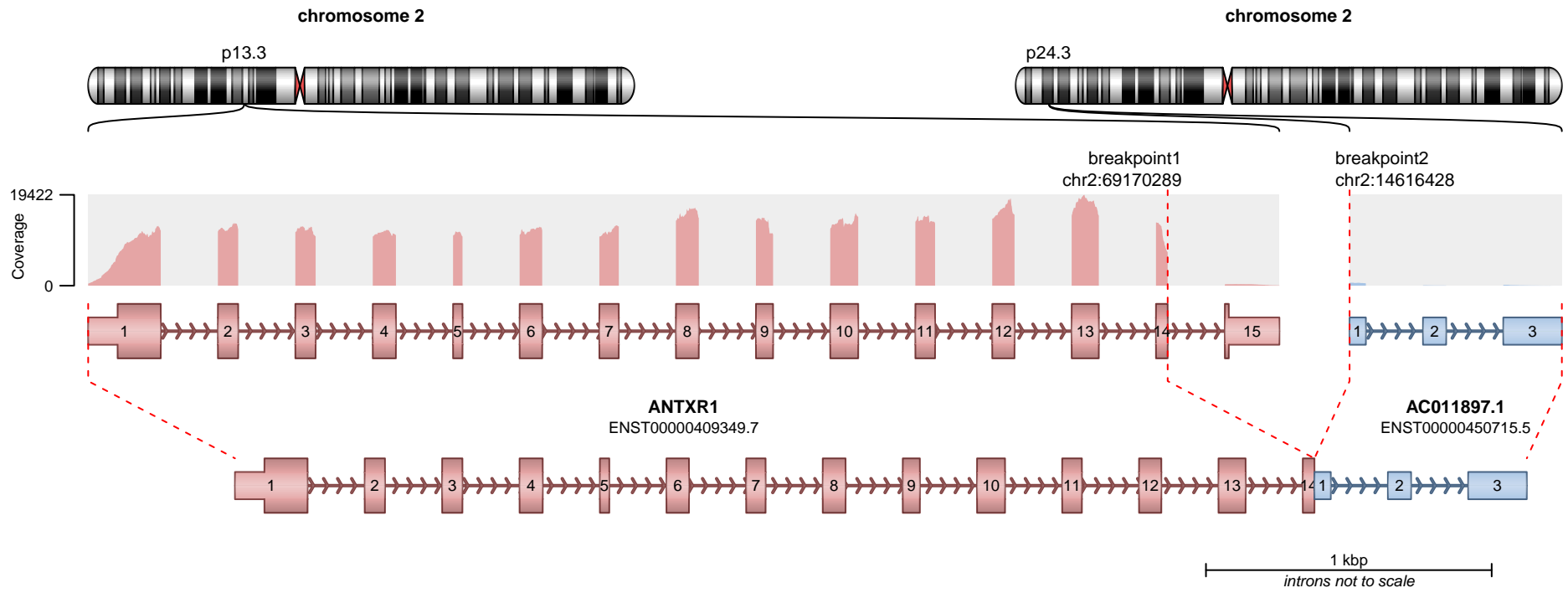

**RETAINED PROTEIN DOMAINS**  
reading frame unclear

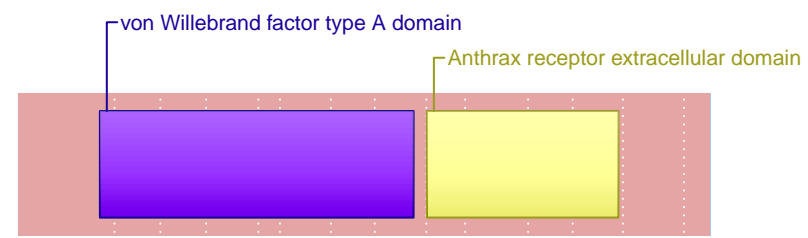

**SUPPORTING READ COUNT**

Split reads = 632  
Discordant mates = 17

- translocation
- duplication
- deletion
- inversion

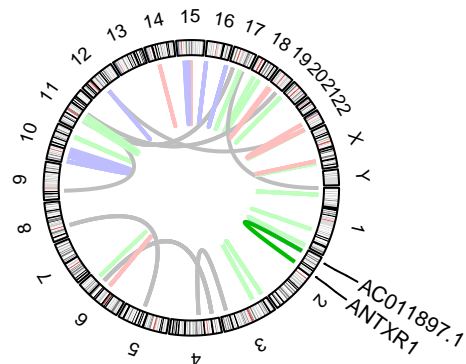
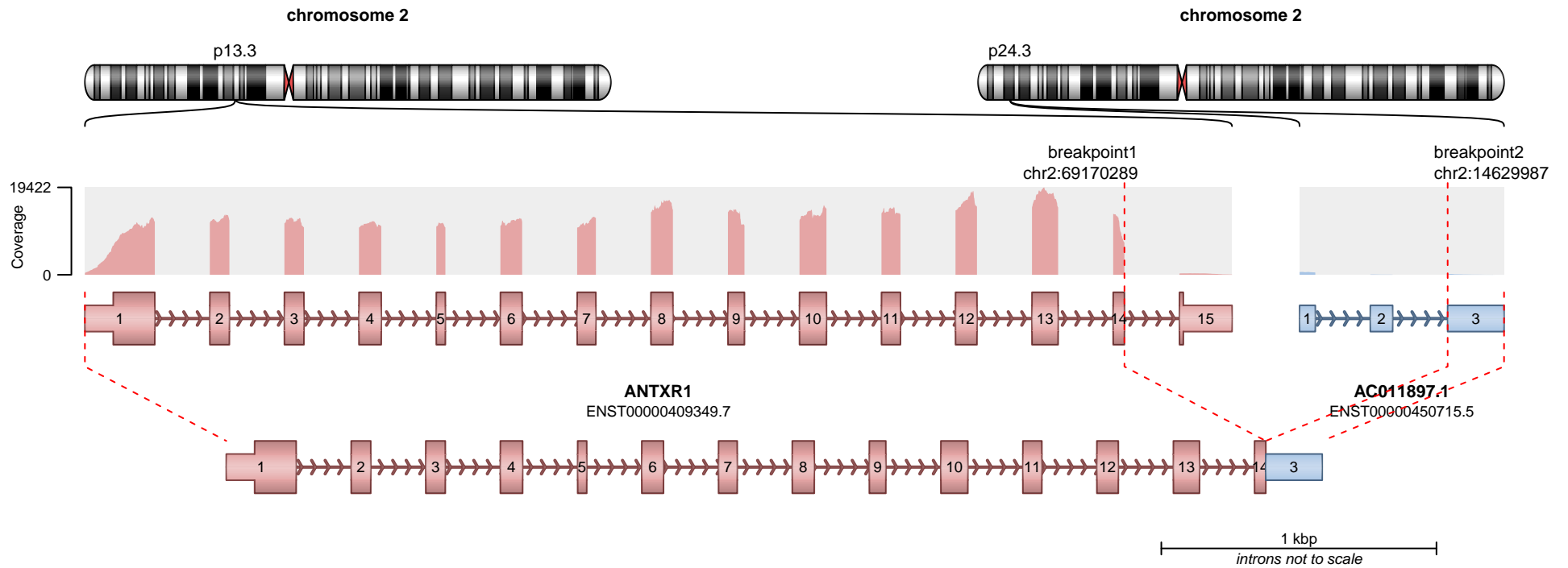

**RETAINED PROTEIN DOMAINS**  
reading frame unclear

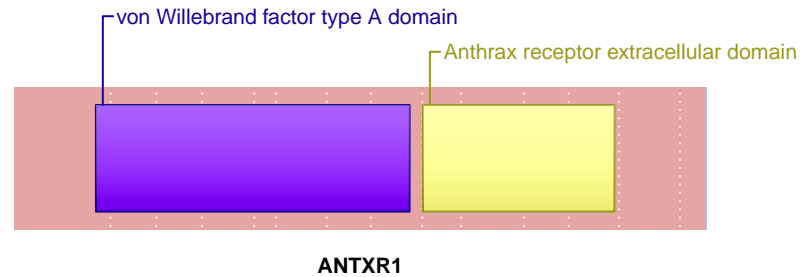

**SUPPORTING READ COUNT**

Split reads = 6  
Discordant mates = 2

— translocation — deletion  
— duplication — inversion

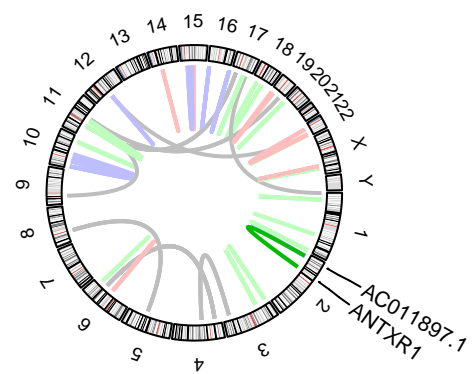
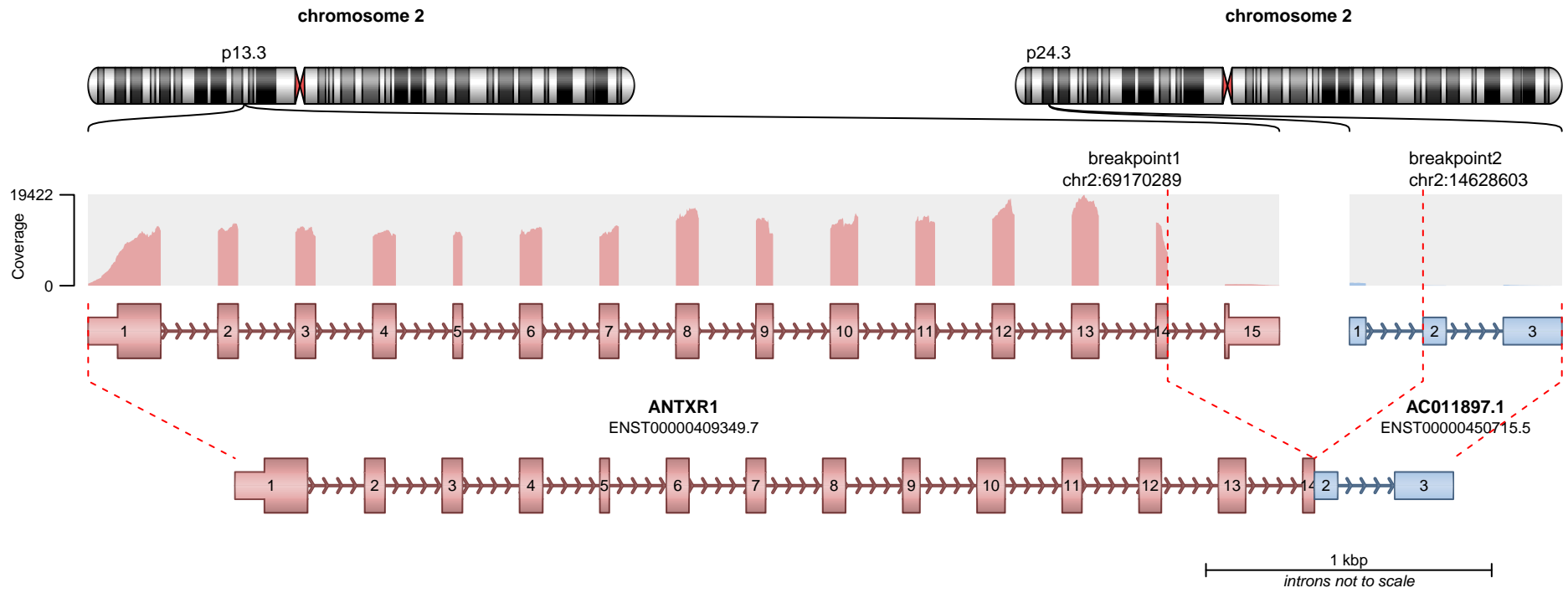

**RETAINED PROTEIN DOMAINS**  
reading frame unclear

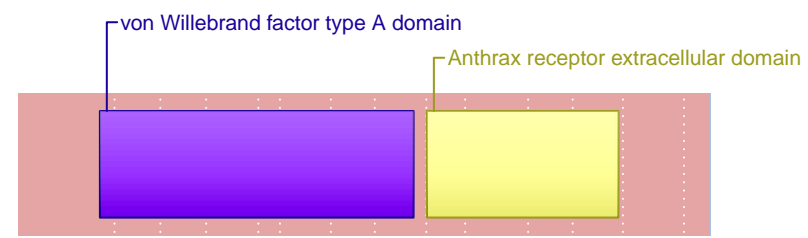

**SUPPORTING READ COUNT**

Split reads = 1  
Discordant mates = 3

- translocation
- duplication
- deletion
- inversion

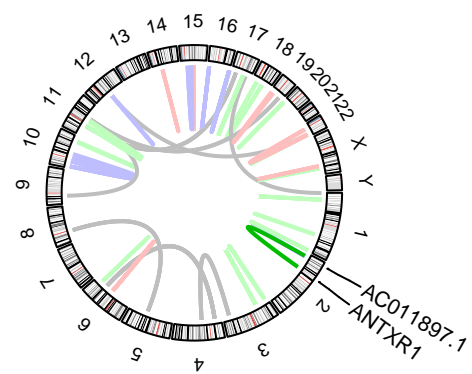
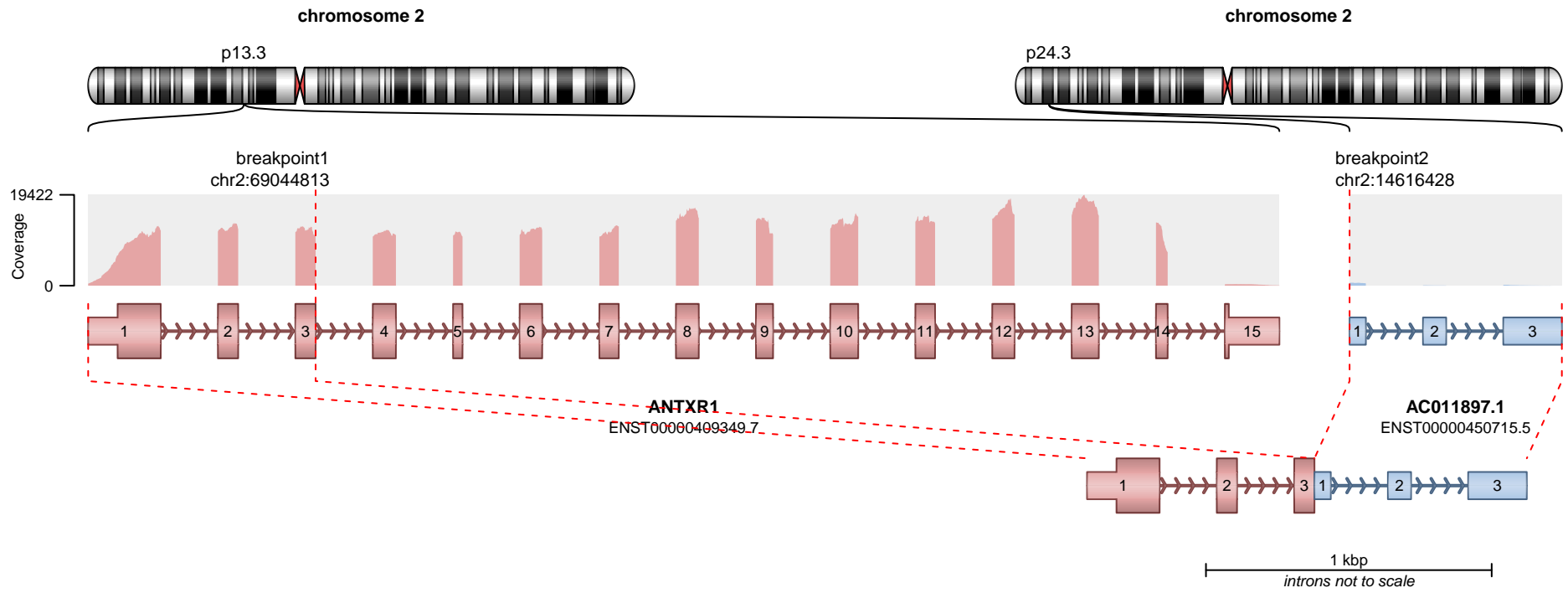

**RETAINED PROTEIN DOMAINS**  
reading frame unclear

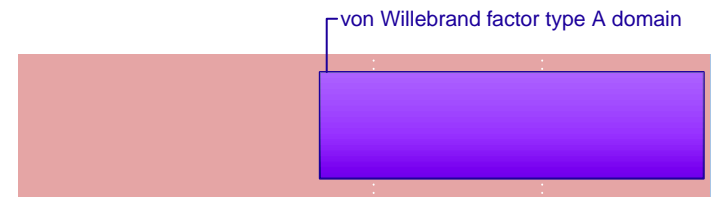

**SUPPORTING READ COUNT**

Split reads = 1  
Discordant mates = 0

- translocation
- duplication
- deletion
- inversion

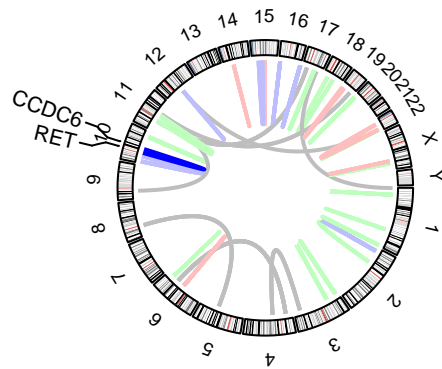
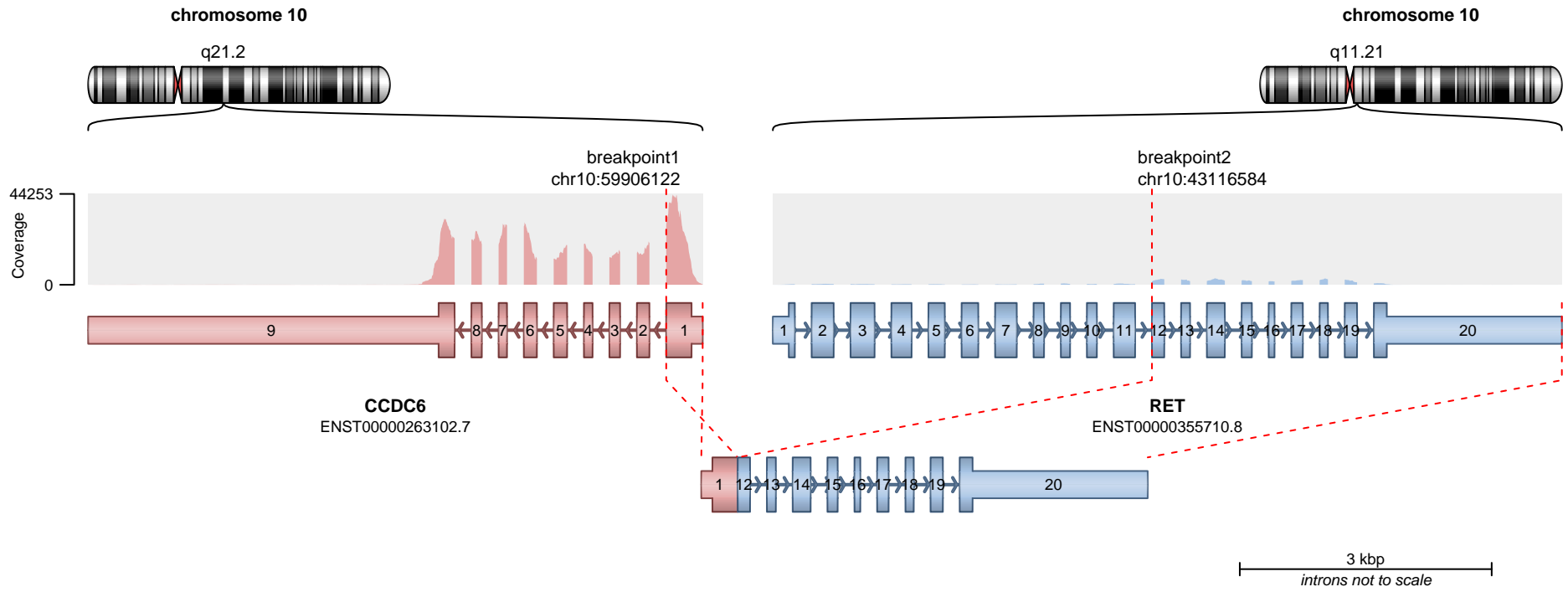

**RETAINED PROTEIN DOMAINS**  
reading frame unclear

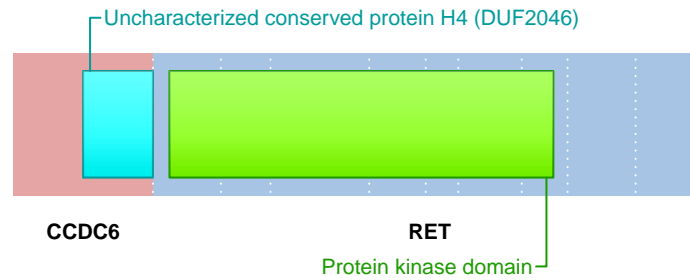

**SUPPORTING READ COUNT**

Split reads = 537  
Discordant mates = 20

- translocation
- duplication
- deletion
- inversion

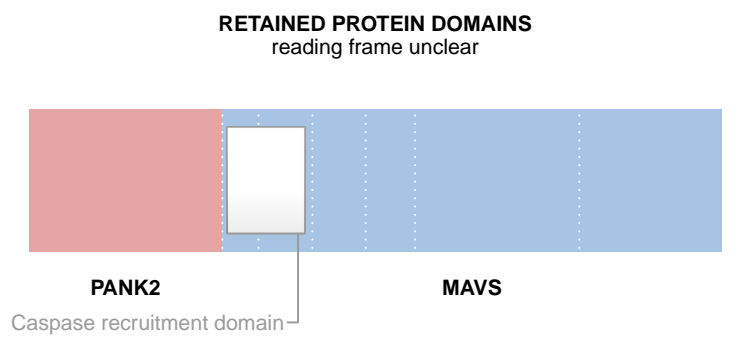
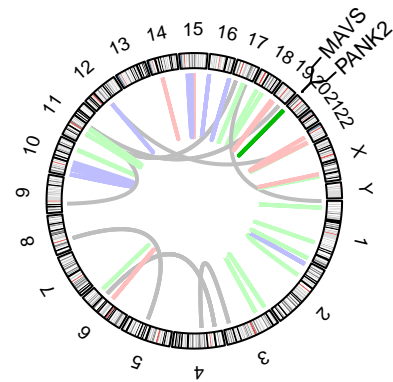
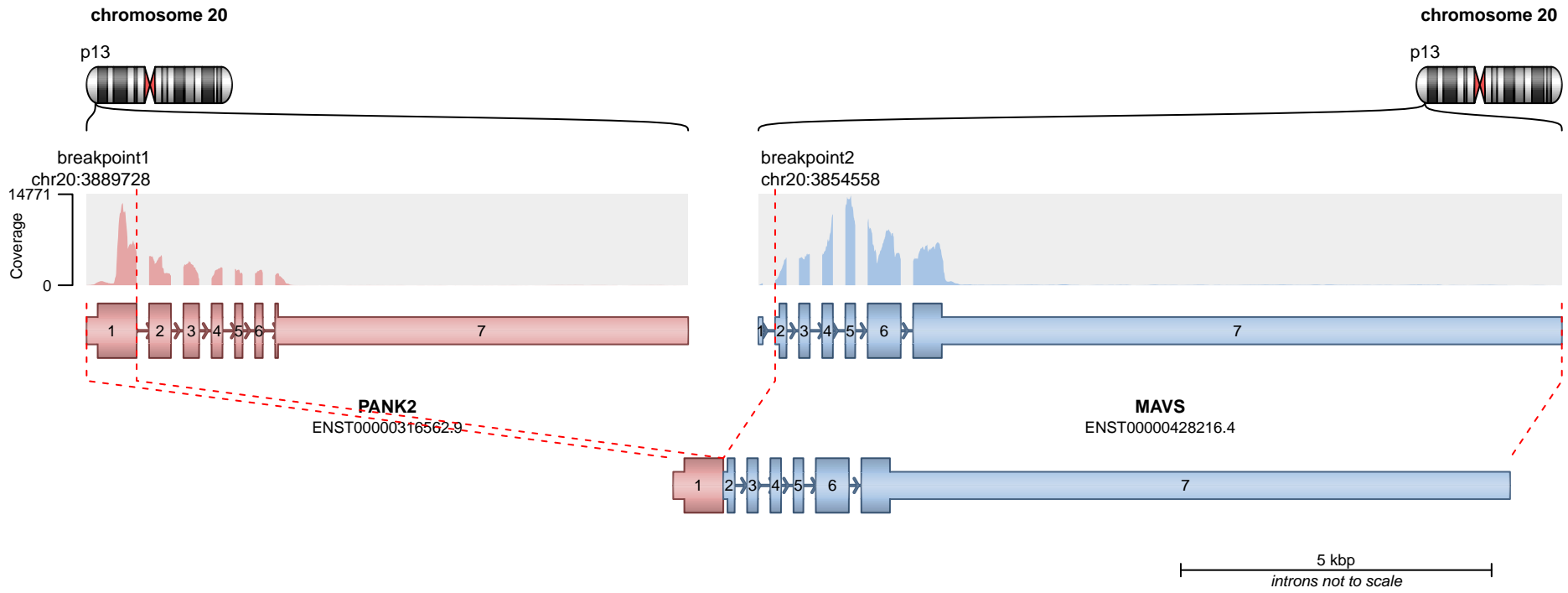

**SUPPORTING READ COUNT**

Split reads = 204  
Discordant mates = 3

— translocation — deletion  
— duplication — inversion

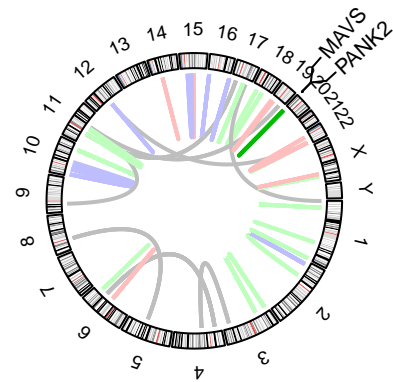
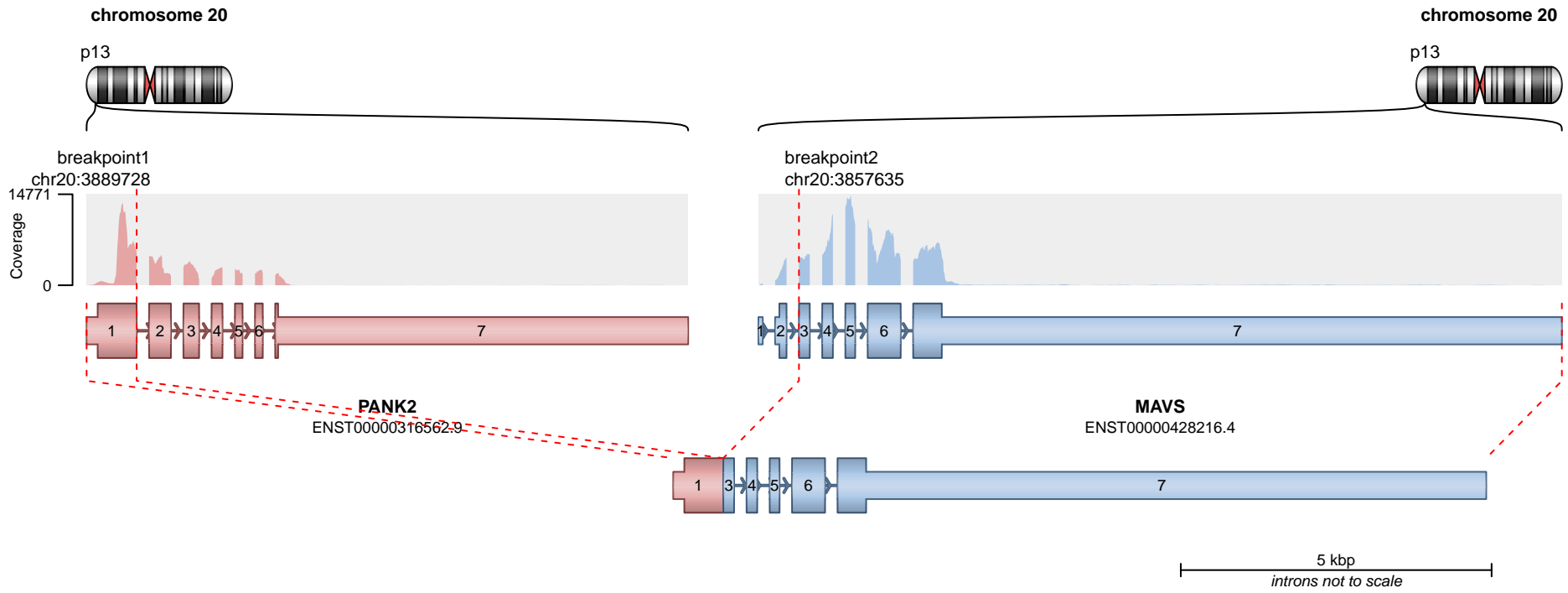

**RETAINED PROTEIN DOMAINS**  
reading frame unclear

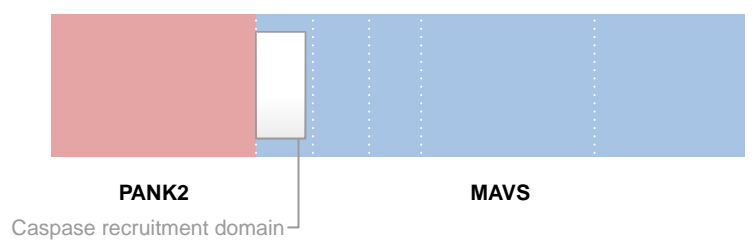

**SUPPORTING READ COUNT**

Split reads = 10  
Discordant mates = 0

- translocation
- duplication
- deletion
- inversion

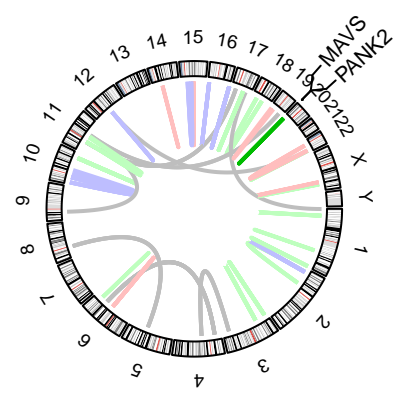
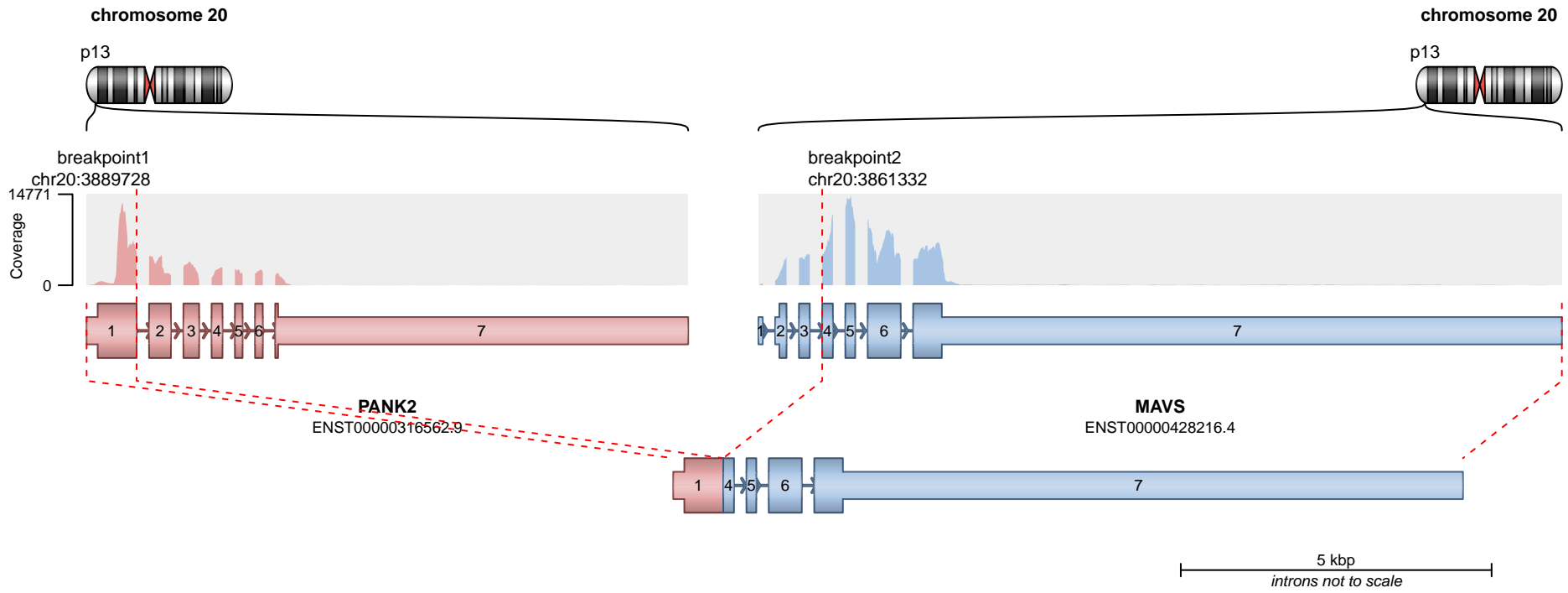

— translocation    — deletion  
— duplication    — inversion

No protein domains retained in fusion.

**SUPPORTING READ COUNT**

Split reads = 7  
Discordant mates = 0

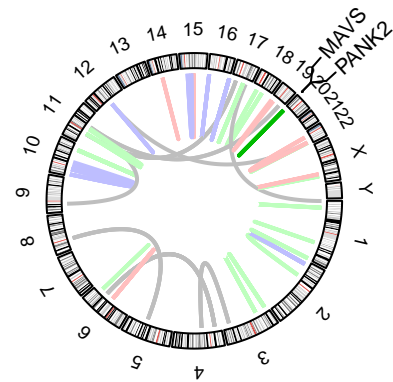
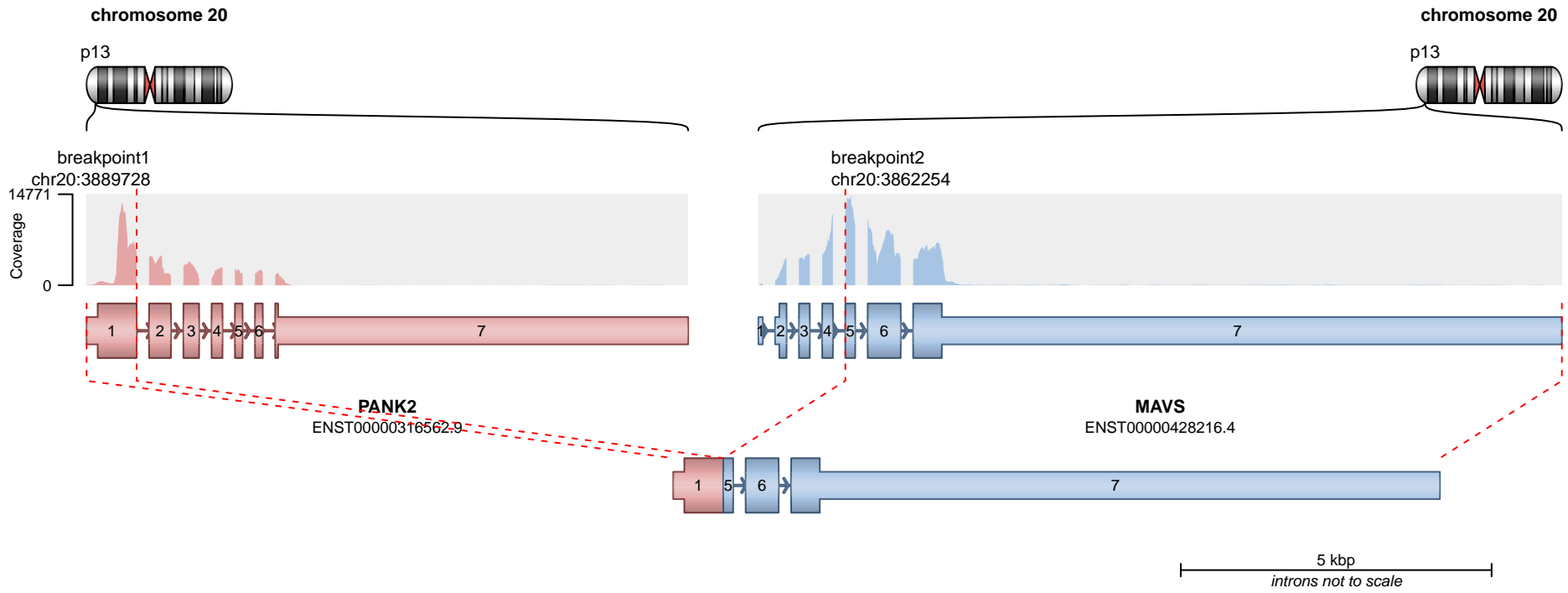

— translocation    — deletion  
— duplication    — inversion

No protein domains retained in fusion.

**SUPPORTING READ COUNT**

Split reads = 2  
Discordant mates = 0

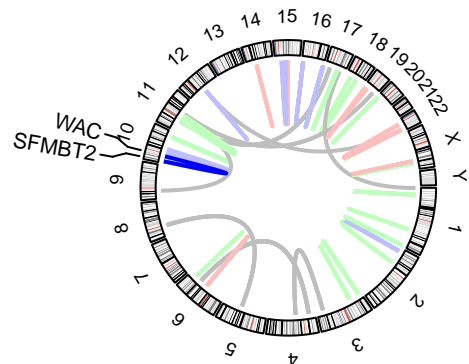
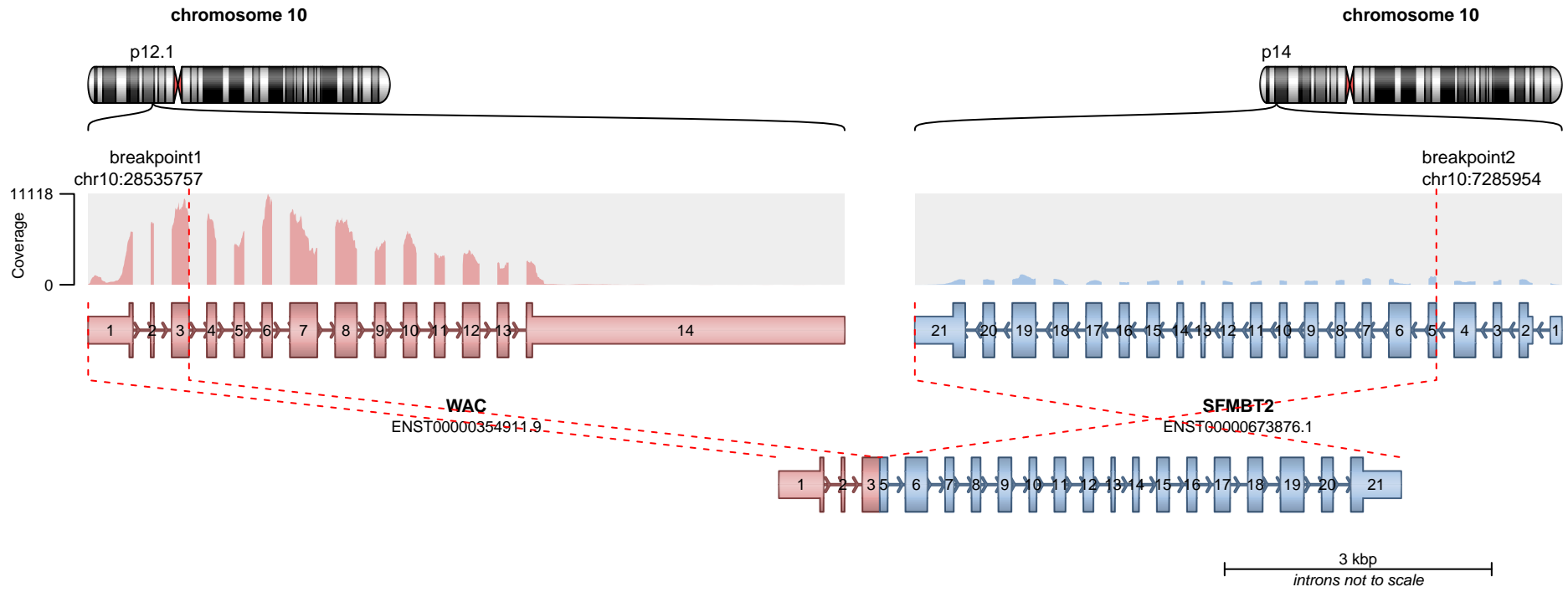

— translocation — deletion  
— duplication — inversion

**RETAINED PROTEIN DOMAINS**  
reading frame unclear

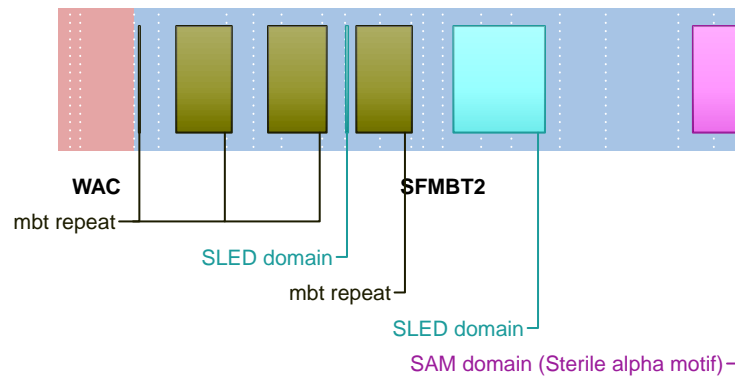

**SUPPORTING READ COUNT**

Split reads = 138  
Discordant mates = 2

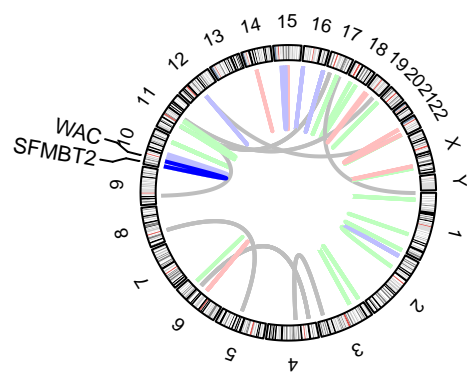
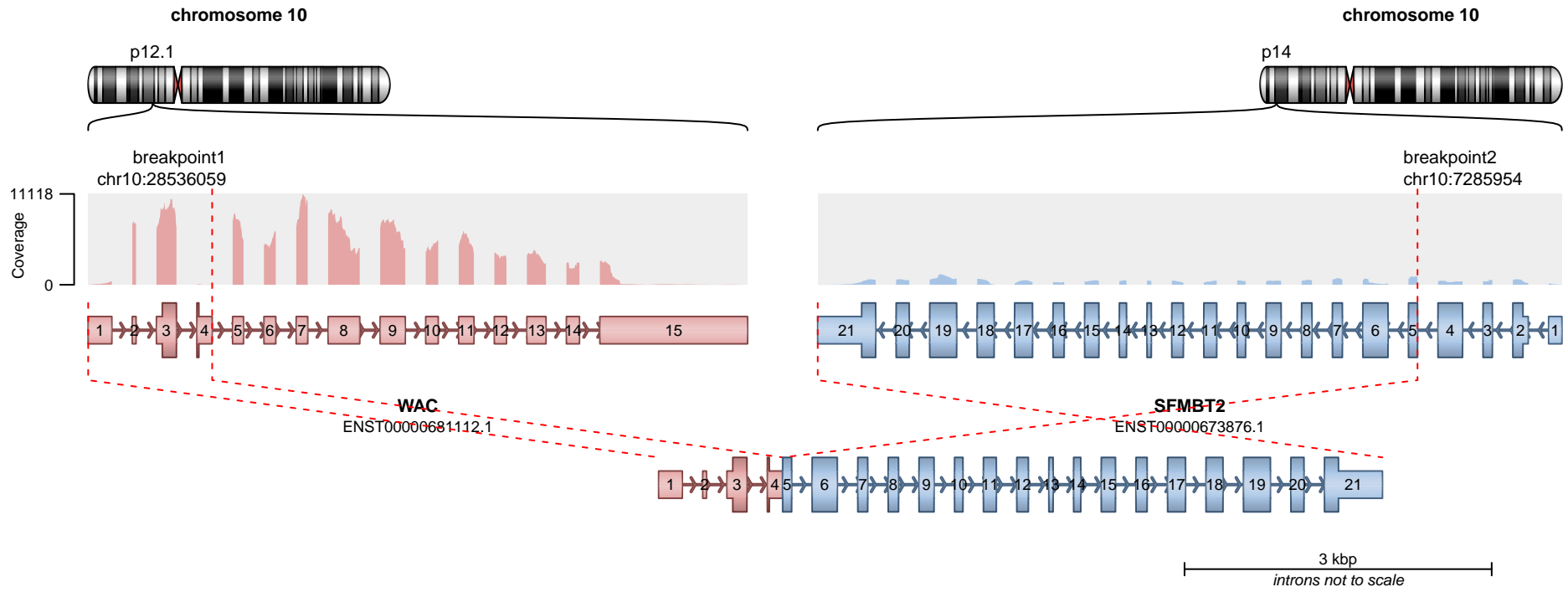

— translocation — deletion  
— duplication — inversion

**RETAINED PROTEIN DOMAINS**  
reading frame unclear

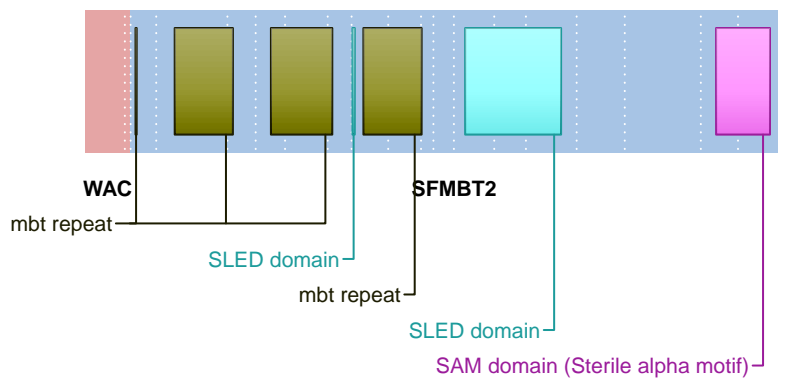

**SUPPORTING READ COUNT**

Split reads = 2  
Discordant mates = 2

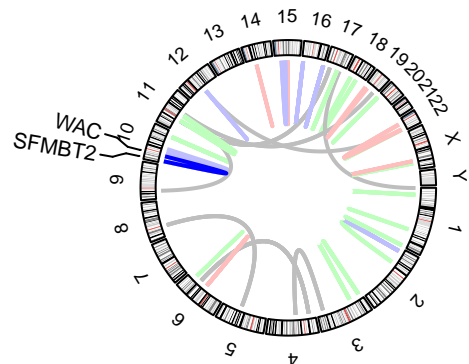
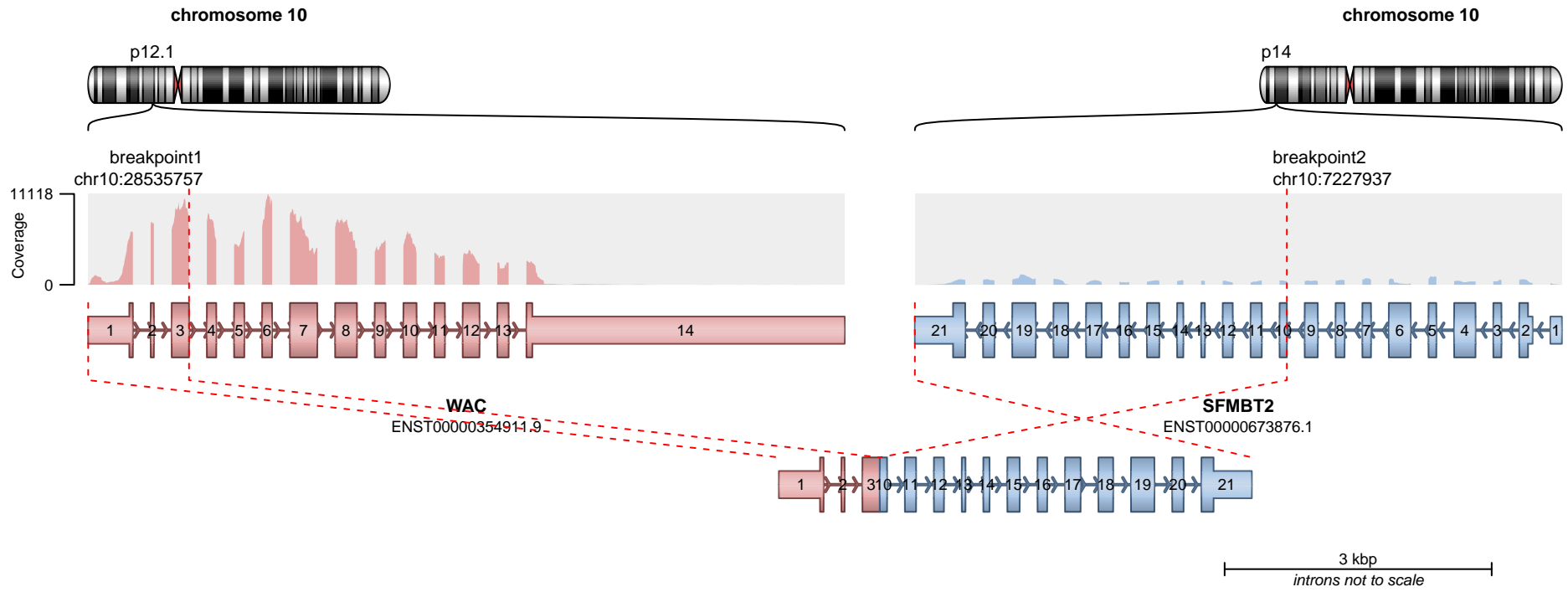

— translocation — deletion  
— duplication — inversion

**RETAINED PROTEIN DOMAINS**  
reading frame unclear

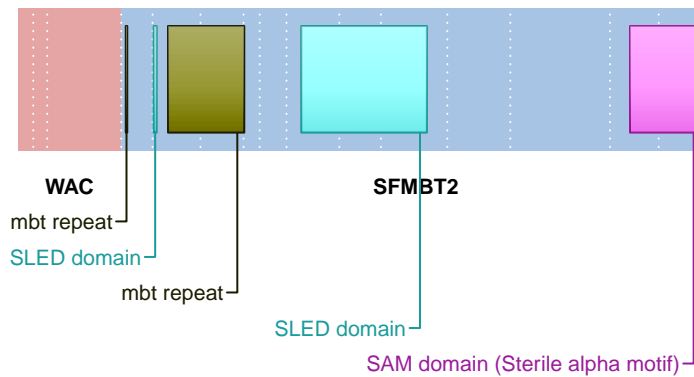

**SUPPORTING READ COUNT**

Split reads = 2  
Discordant mates = 0

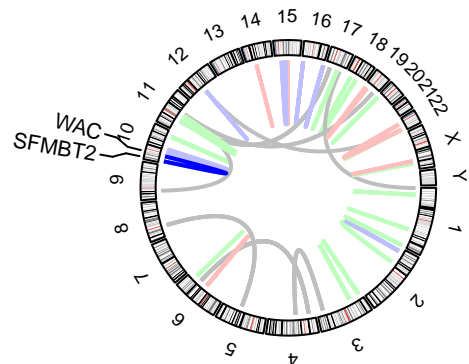
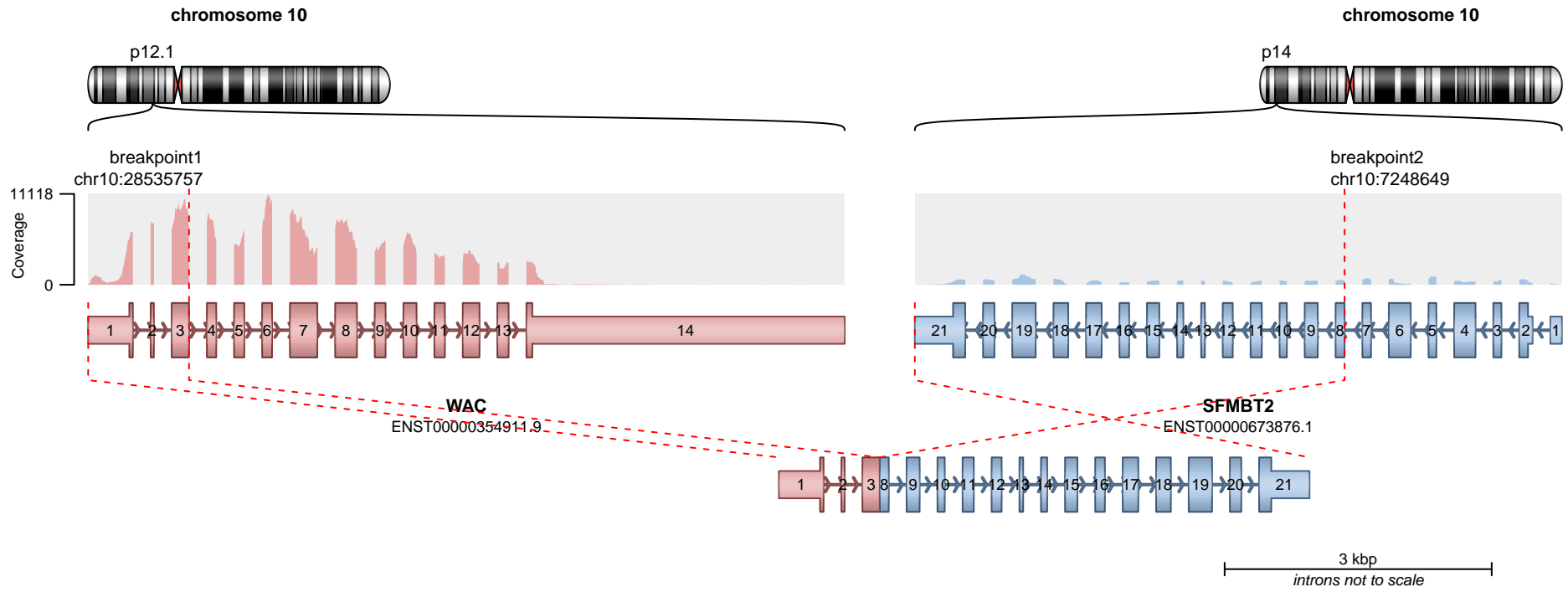

— translocation — deletion  
— duplication — inversion

**RETAINED PROTEIN DOMAINS**  
reading frame unclear

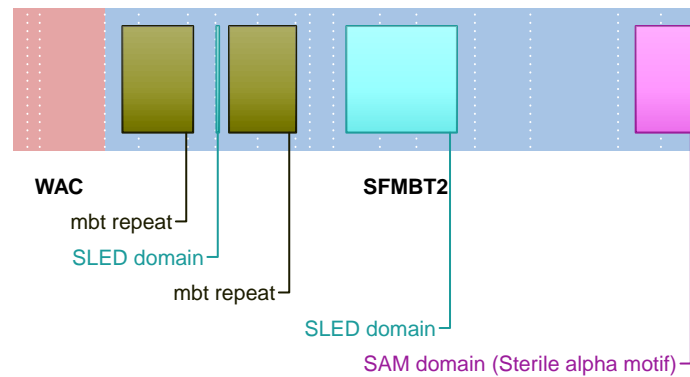

**SUPPORTING READ COUNT**

Split reads = 1  
Discordant mates = 0

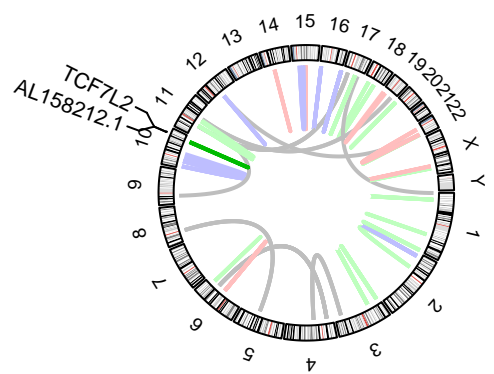
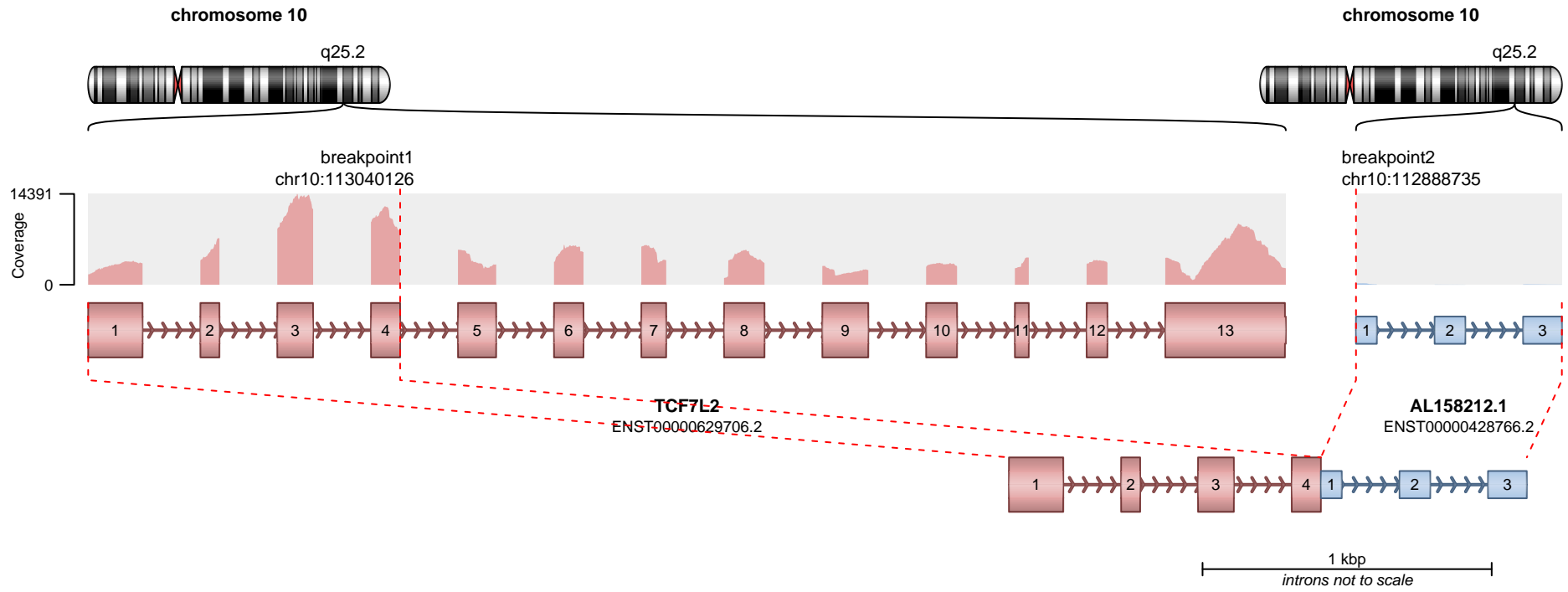

**RETAINED PROTEIN DOMAINS**  
reading frame unclear

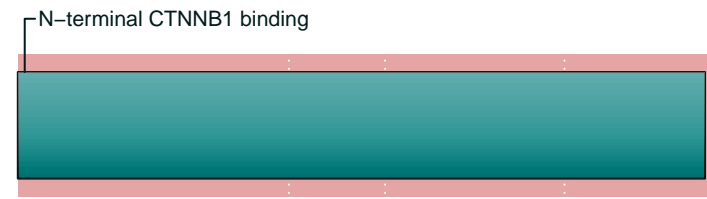

**SUPPORTING READ COUNT**

Split reads = 121  
Discordant mates = 3

- translocation
- duplication
- deletion
- inversion

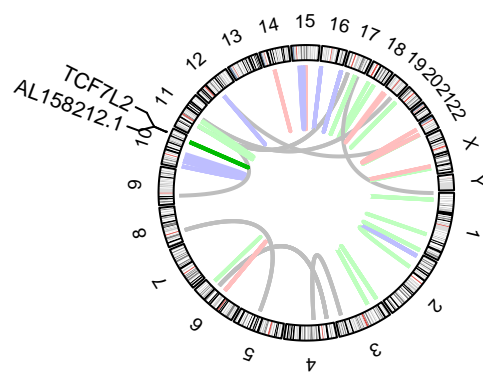
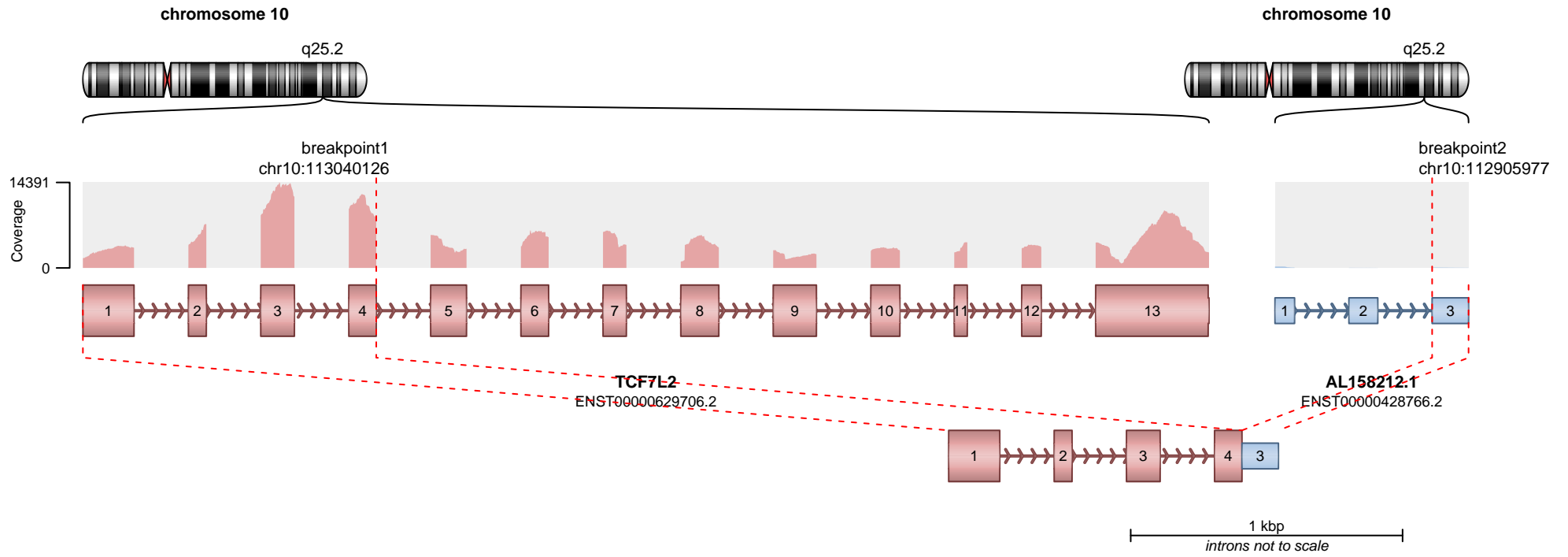

**RETAINED PROTEIN DOMAINS**  
reading frame unclear

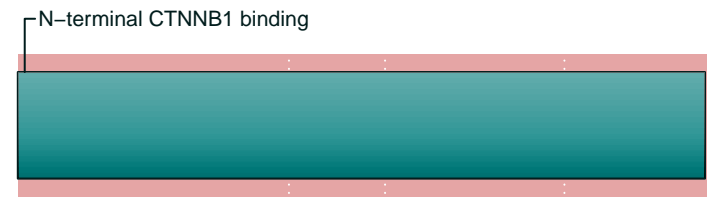

**SUPPORTING READ COUNT**

Split reads = 24  
Discordant mates = 0

- translocation
- duplication
- deletion
- inversion

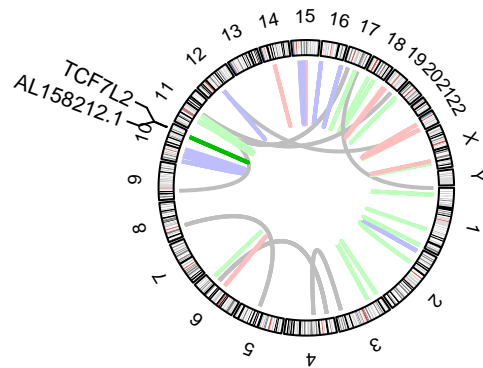
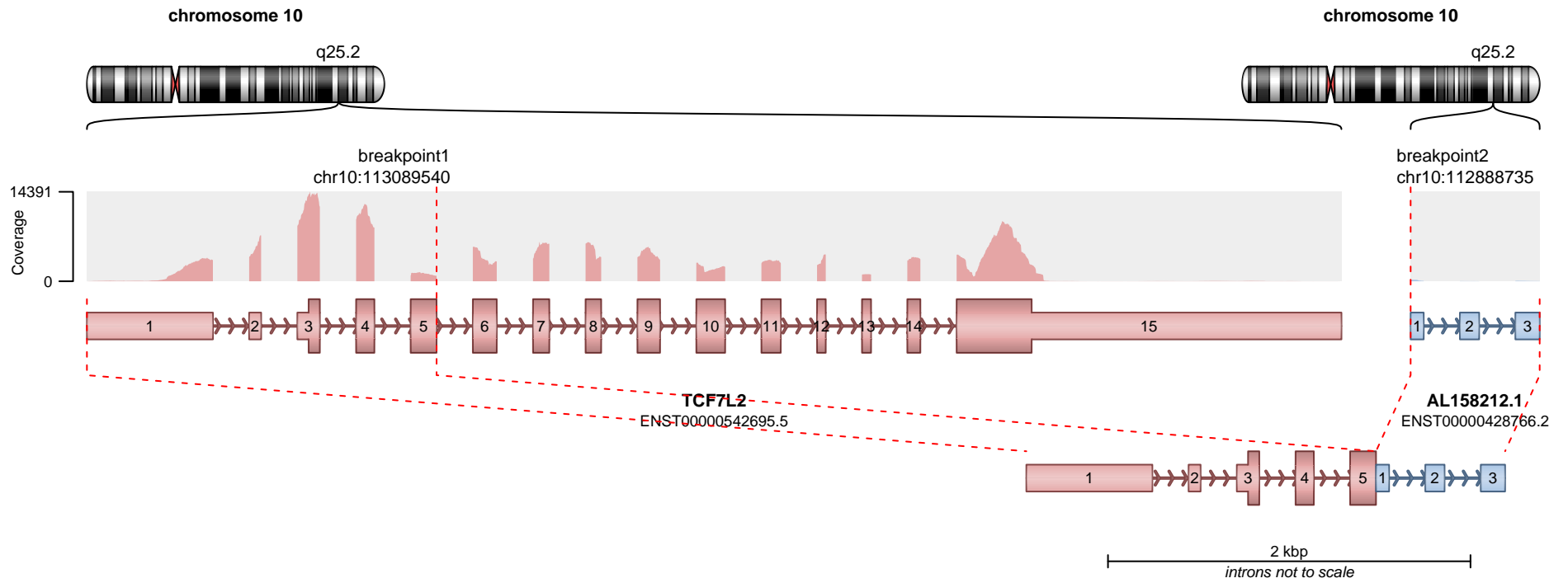

**RETAINED PROTEIN DOMAINS**  
reading frame unclear

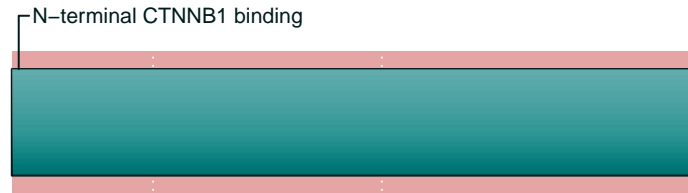

**SUPPORTING READ COUNT**

Split reads = 17  
Discordant mates = 3

— translocation — deletion  
— duplication — inversion

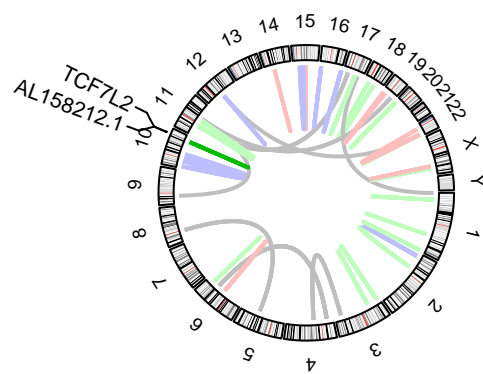
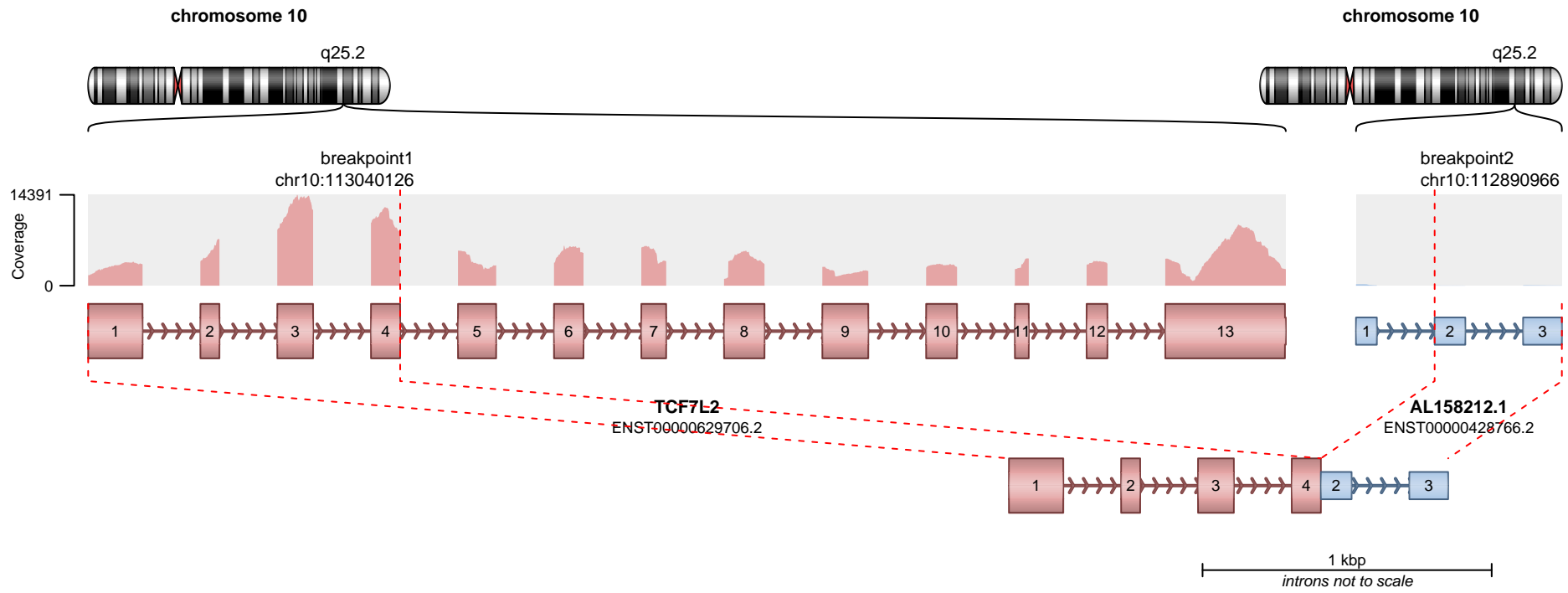

**RETAINED PROTEIN DOMAINS**  
reading frame unclear

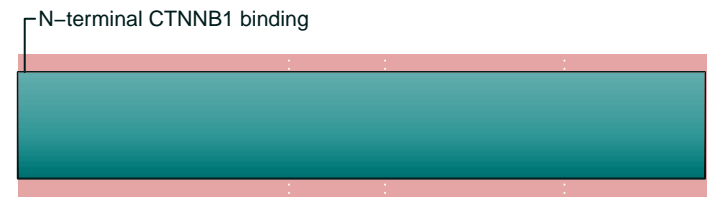

**SUPPORTING READ COUNT**

Split reads = 3  
Discordant mates = 0

- translocation
- duplication
- deletion
- inversion

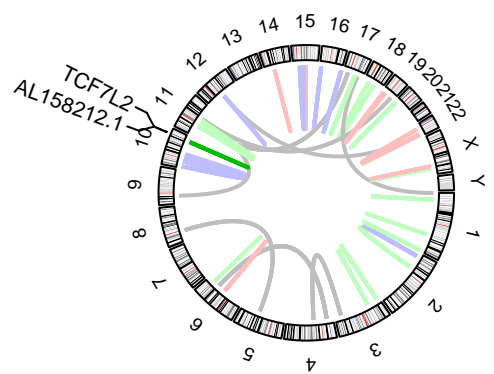
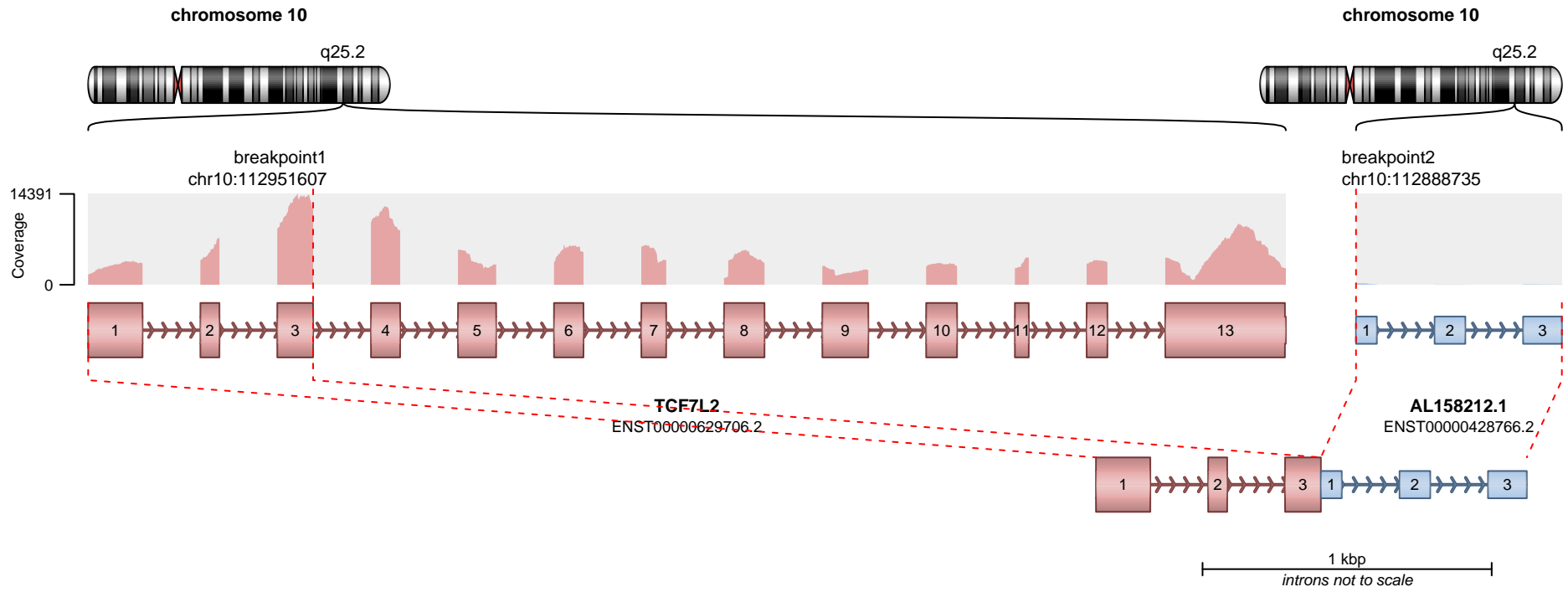

**RETAINED PROTEIN DOMAINS**  
reading frame unclear

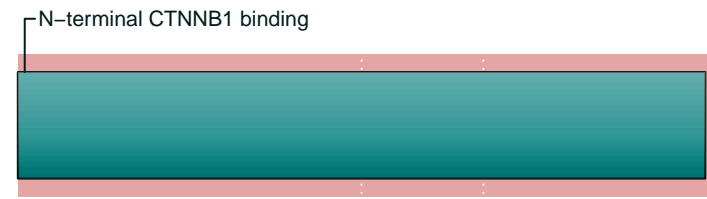

**SUPPORTING READ COUNT**

Split reads = 2  
Discordant mates = 1

- translocation
- duplication
- deletion
- inversion

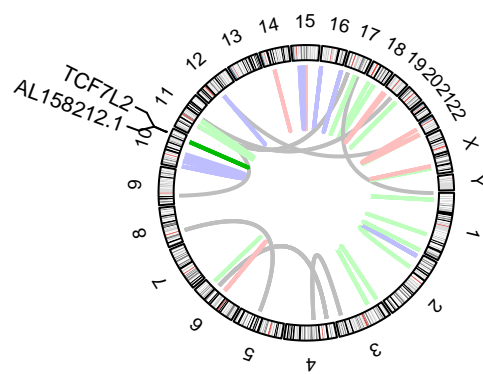
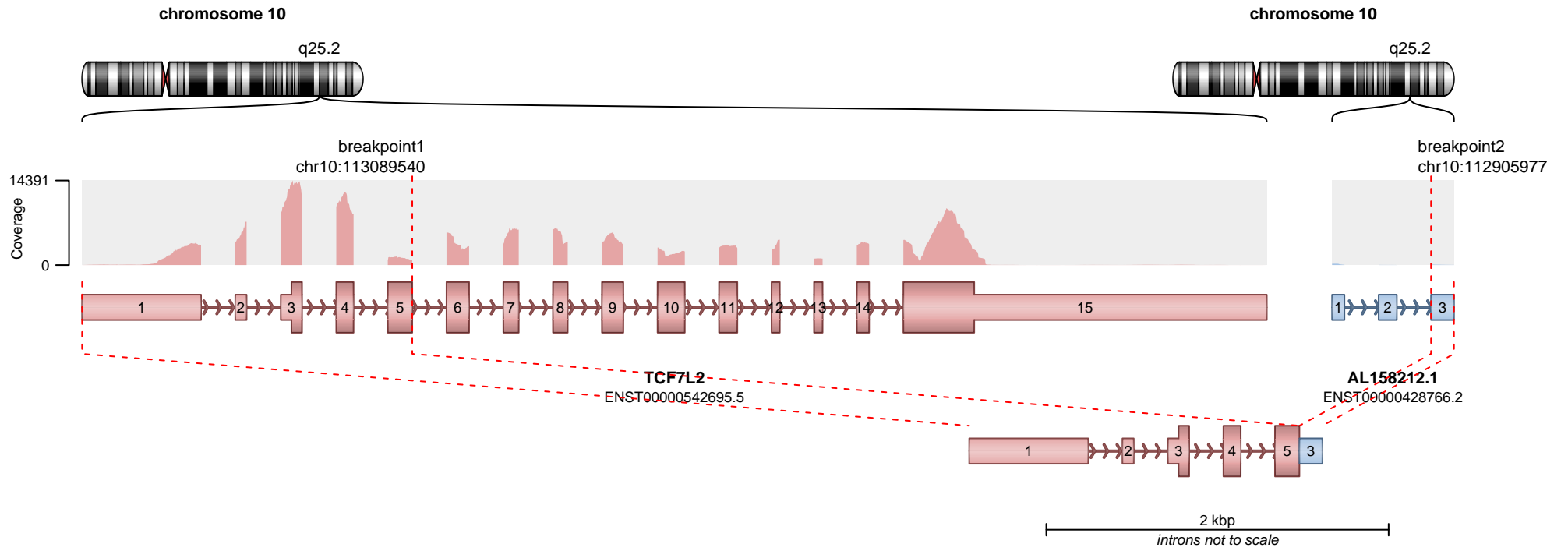

**RETAINED PROTEIN DOMAINS**  
reading frame unclear

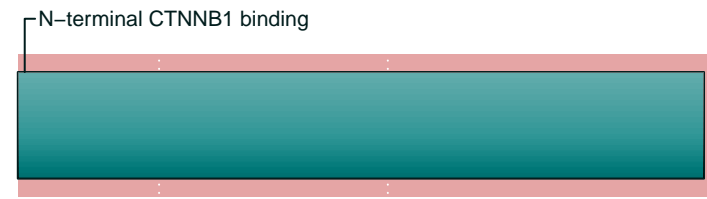

**SUPPORTING READ COUNT**

Split reads = 2  
Discordant mates = 0

- translocation
- duplication
- deletion
- inversion

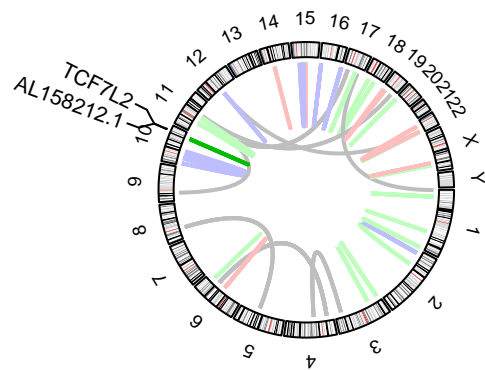
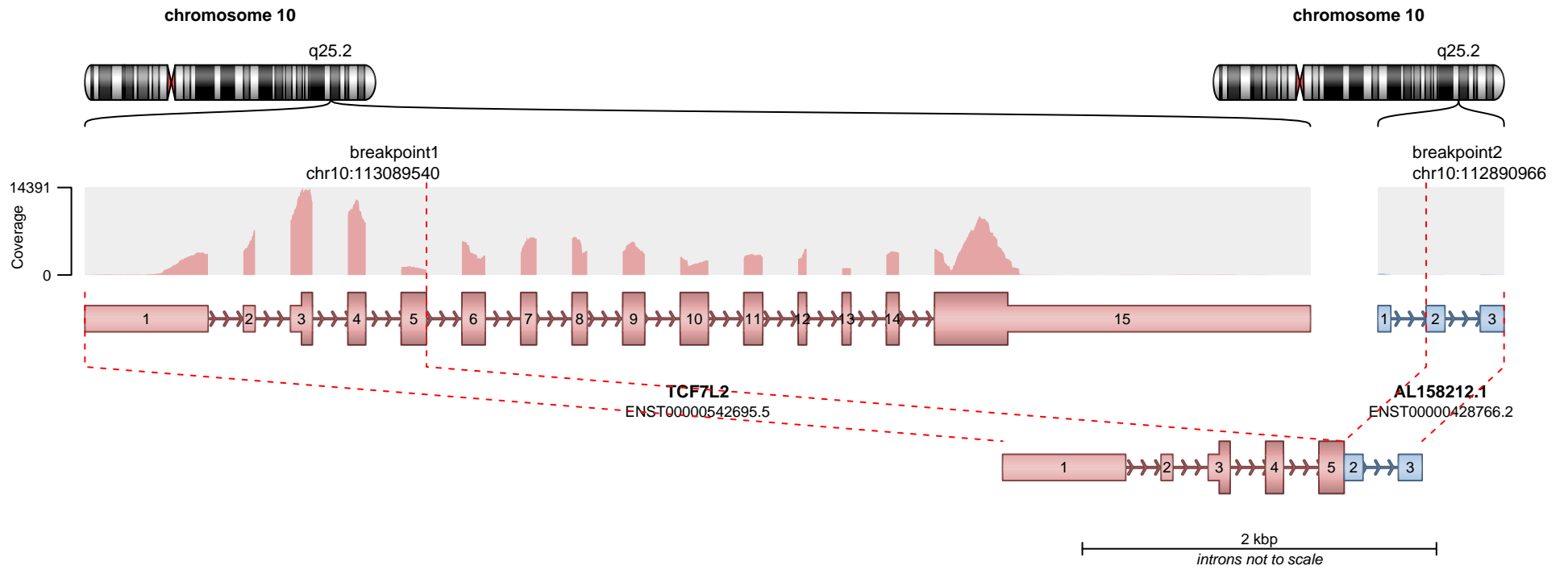

**RETAINED PROTEIN DOMAINS**  
reading frame unclear

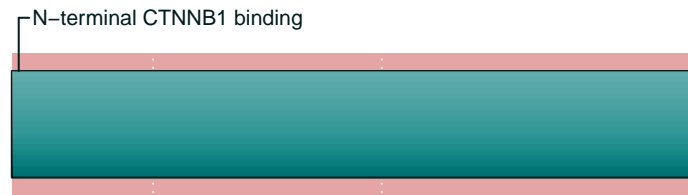

TCF7L2

**SUPPORTING READ COUNT**

Split reads = 1  
Discordant mates = 0

— translocation — deletion  
— duplication — inversion

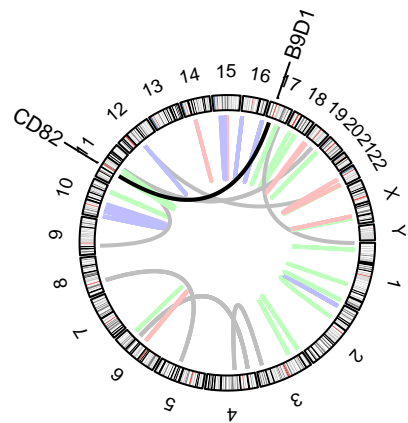
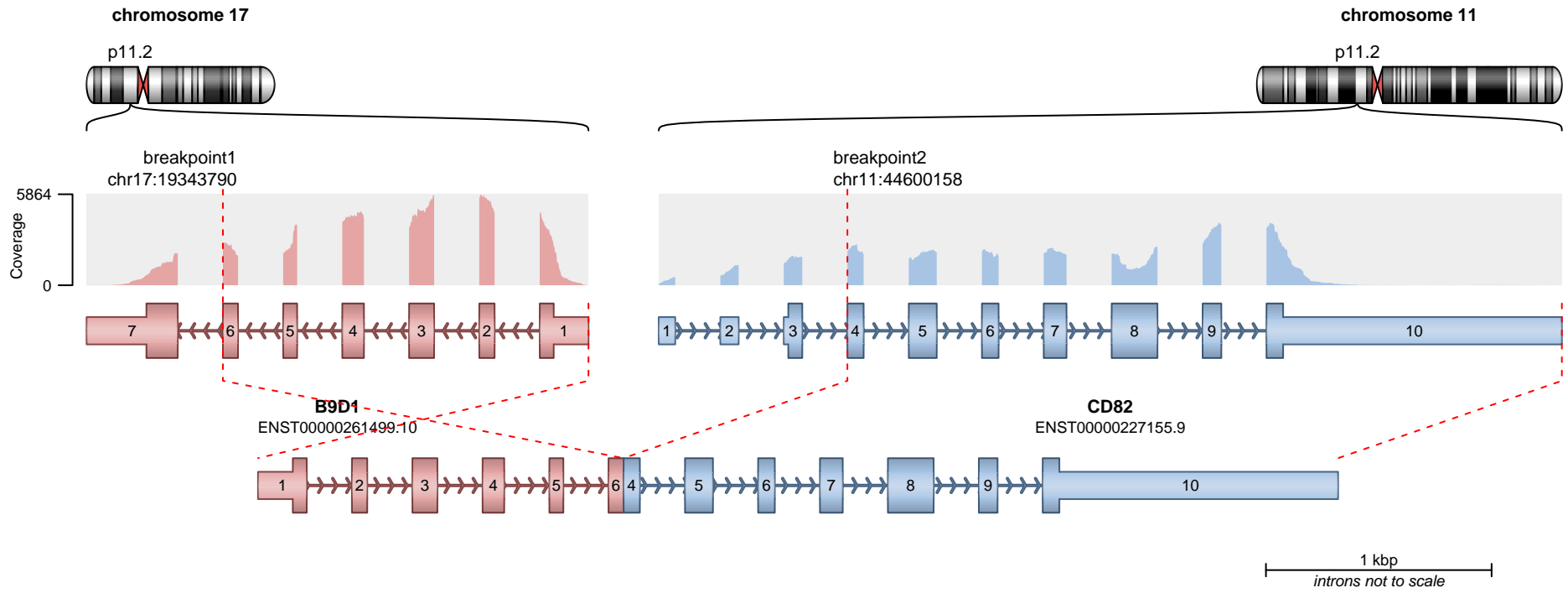

**RETAINED PROTEIN DOMAINS**  
reading frame unclear

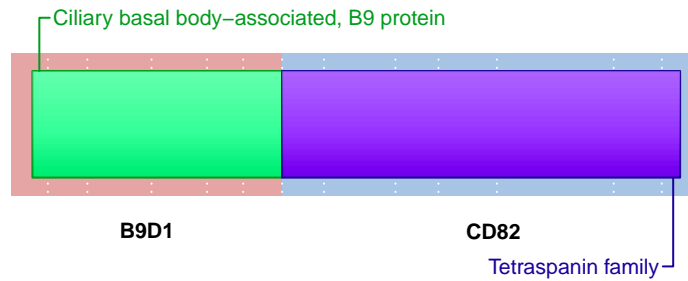

**SUPPORTING READ COUNT**

Split reads = 102  
Discordant mates = 5

— translocation — deletion  
— duplication — inversion

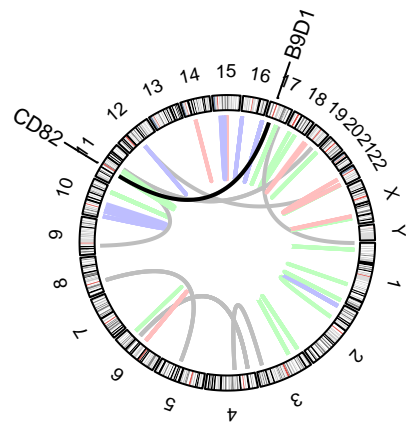
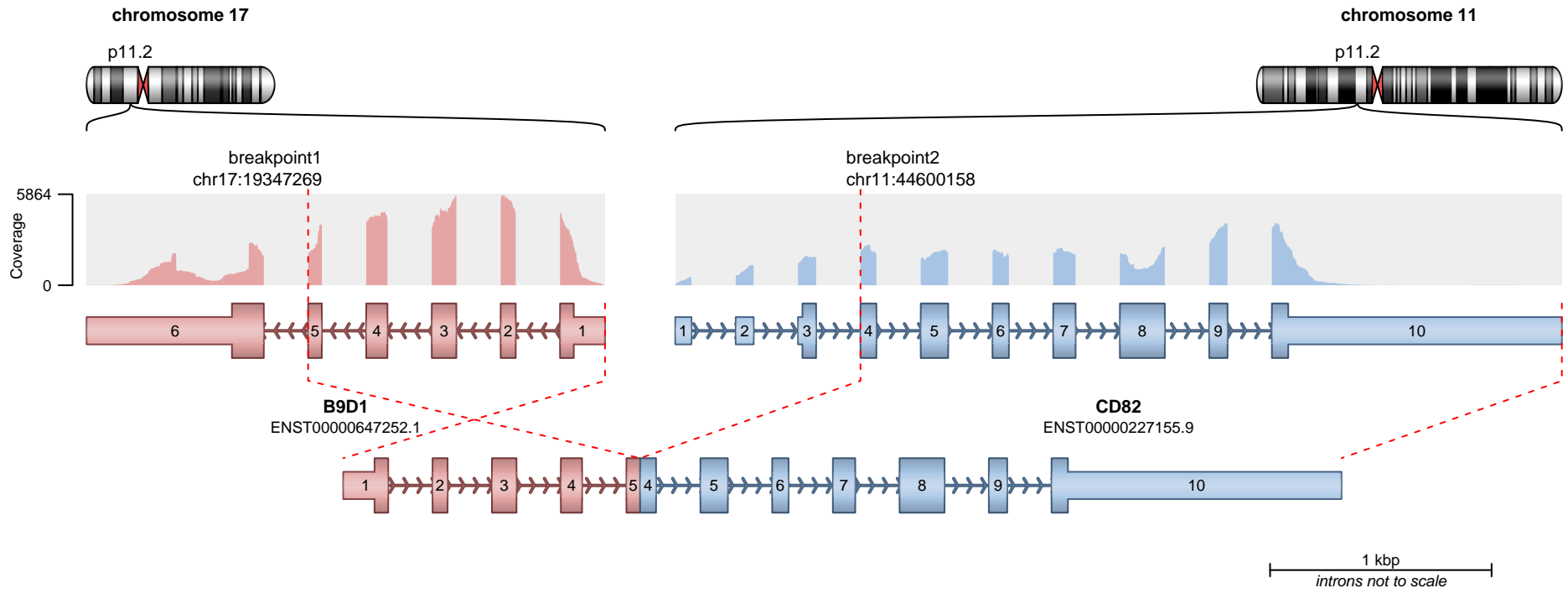

**RETAINED PROTEIN DOMAINS**  
reading frame unclear

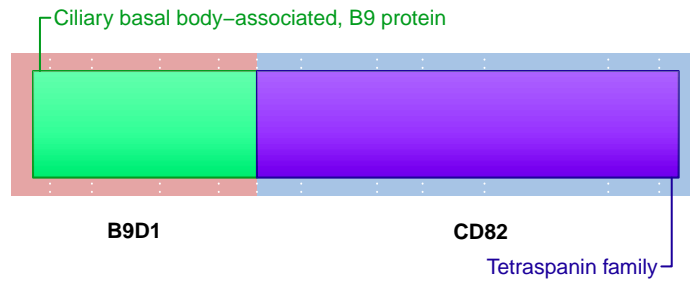

**SUPPORTING READ COUNT**

Split reads = 17  
Discordant mates = 2

- translocation
- duplication
- deletion
- inversion

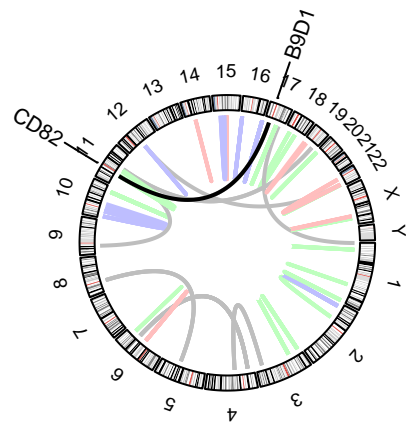
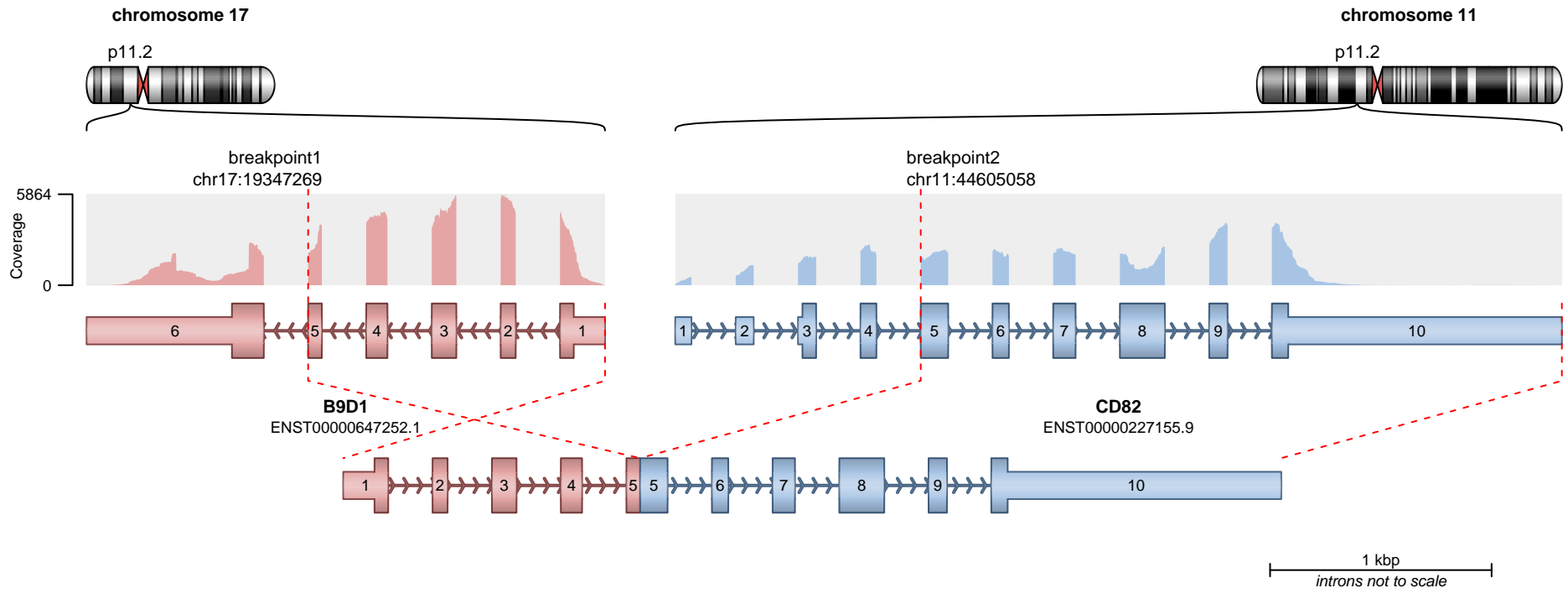

**RETAINED PROTEIN DOMAINS**  
reading frame unclear

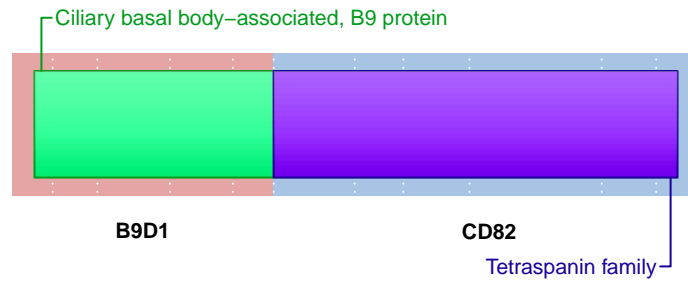

**SUPPORTING READ COUNT**

Split reads = 1  
Discordant mates = 1

- translocation
- duplication
- deletion
- inversion

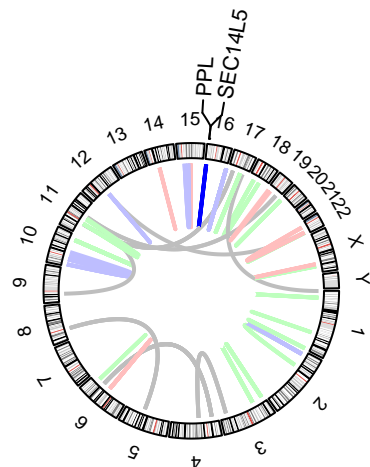
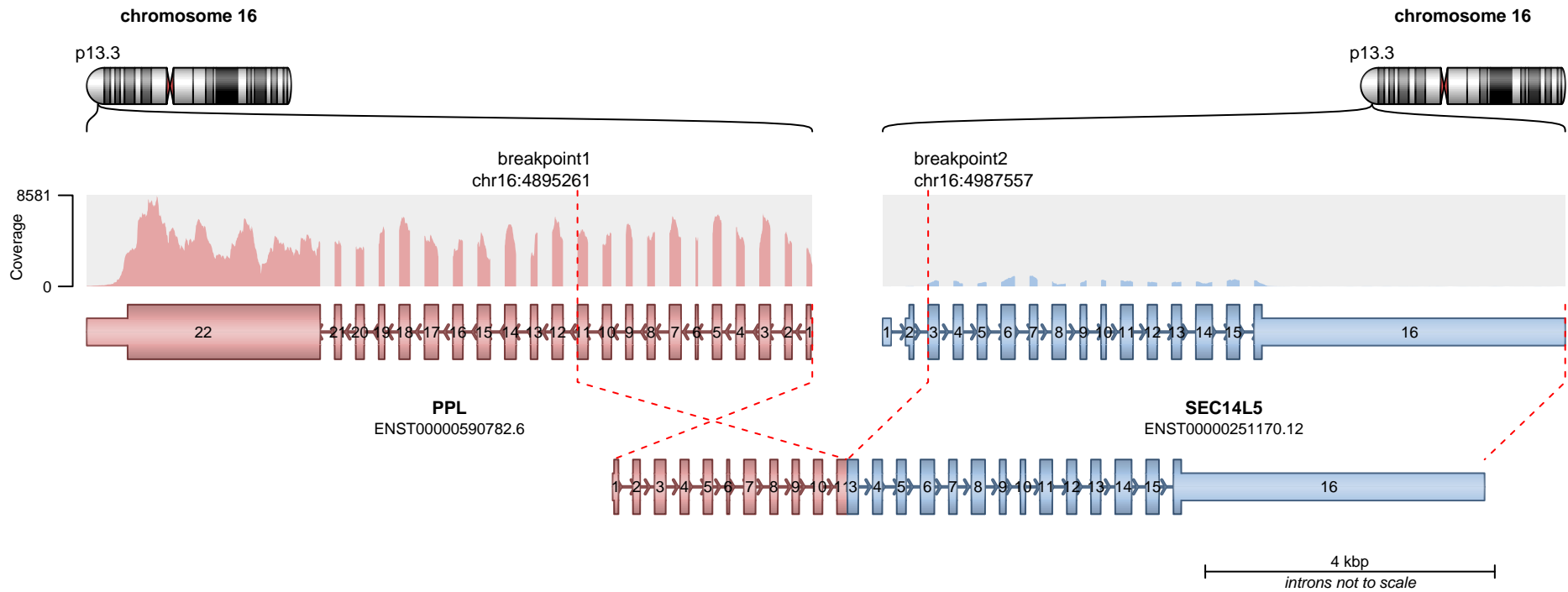

**RETAINED PROTEIN DOMAINS**  
reading frame unclear

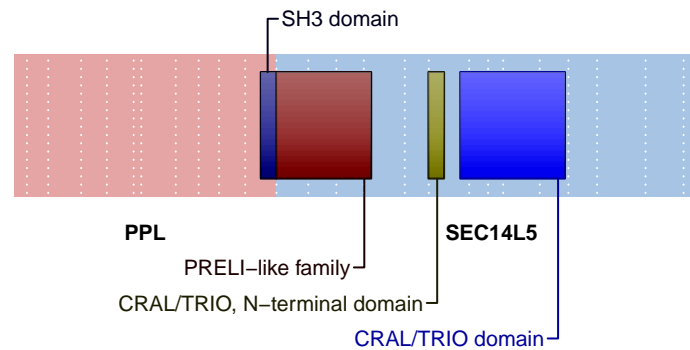

**SUPPORTING READ COUNT**

Split reads = 96  
Discordant mates = 7

- translocation
- duplication
- deletion
- inversion

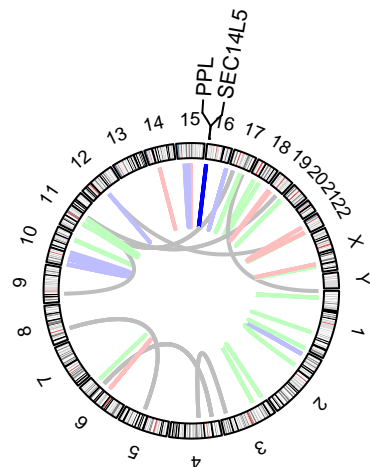
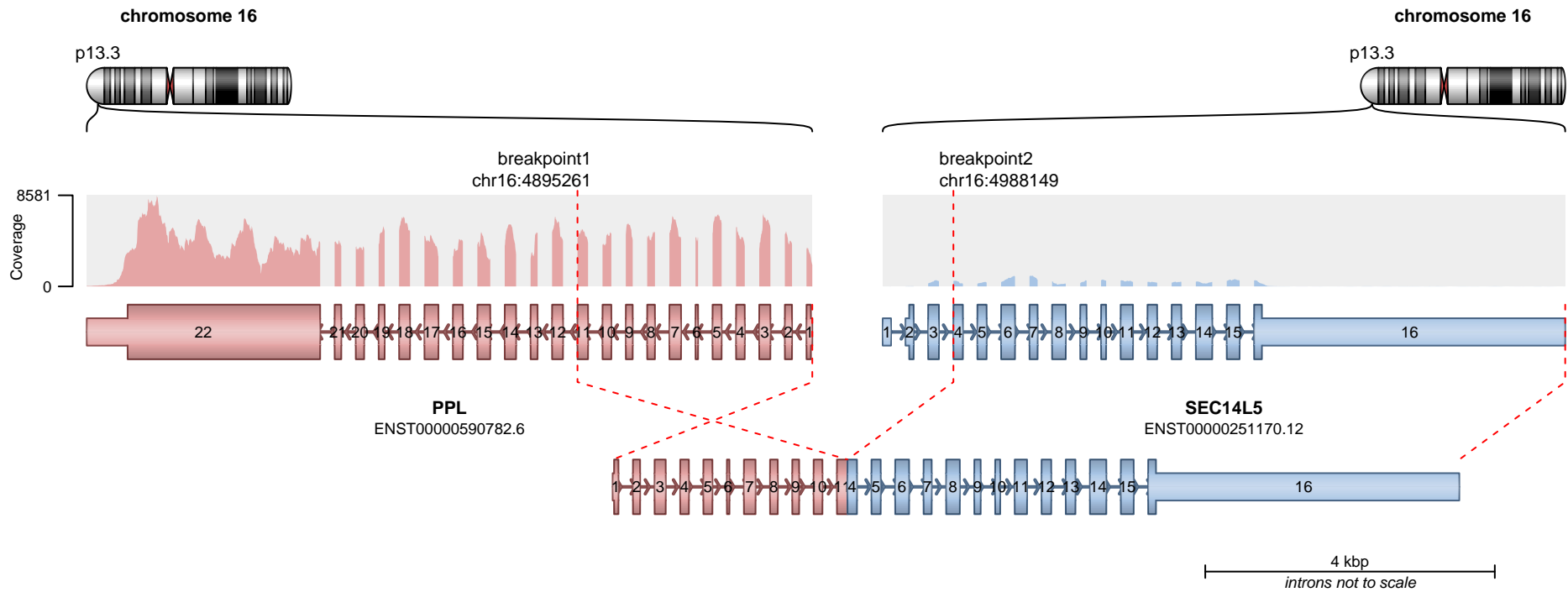

**RETAINED PROTEIN DOMAINS**  
reading frame unclear

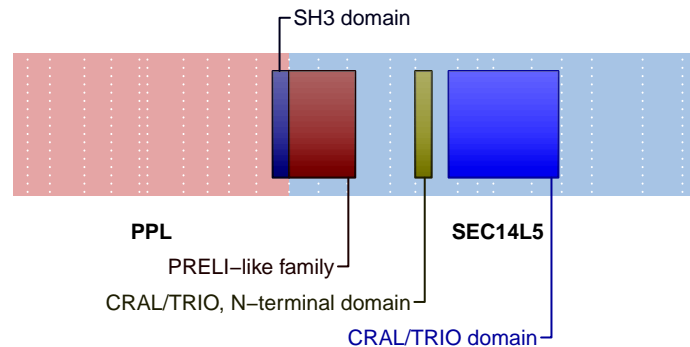

**SUPPORTING READ COUNT**

Split reads = 2  
Discordant mates = 0

— translocation — deletion  
— duplication — inversion

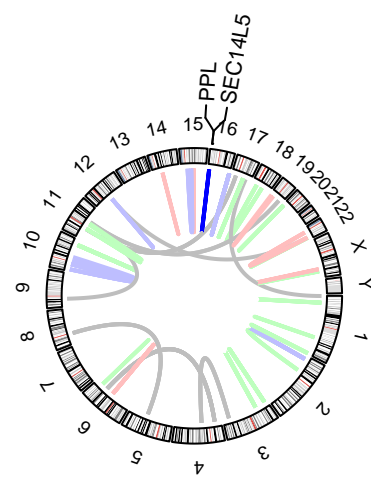
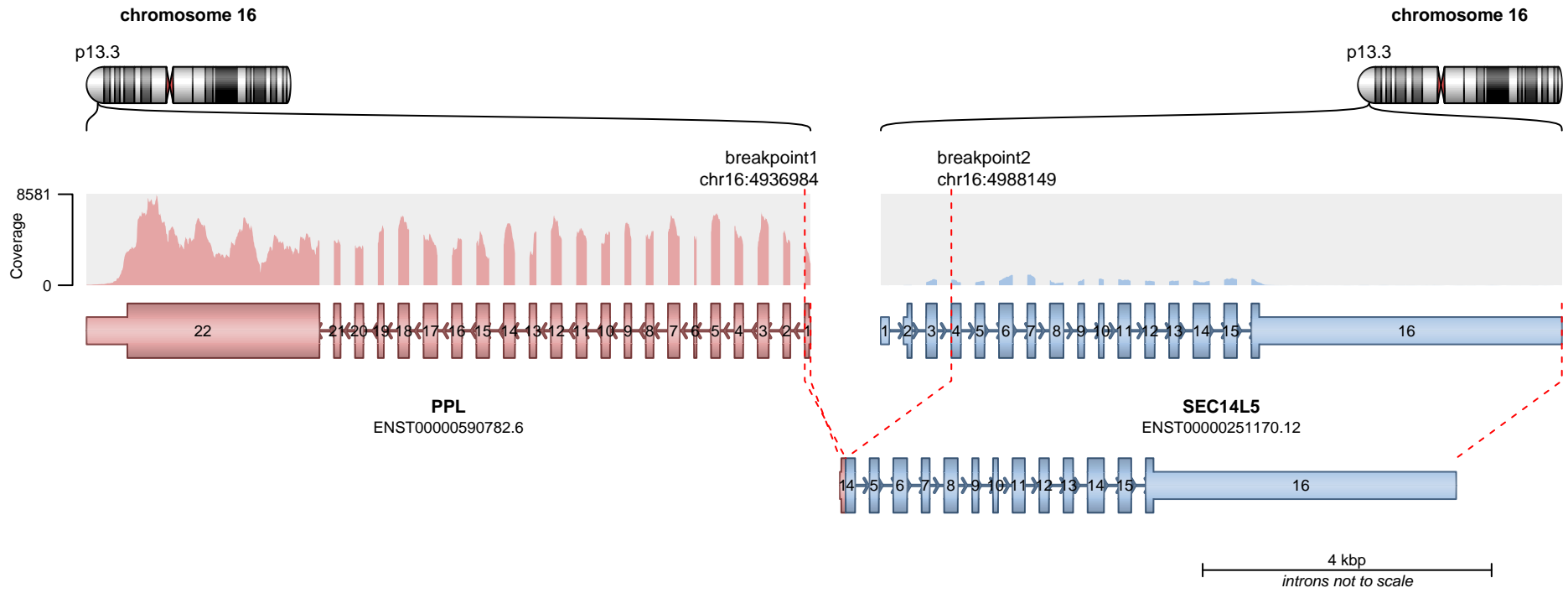

**RETAINED PROTEIN DOMAINS**  
reading frame unclear

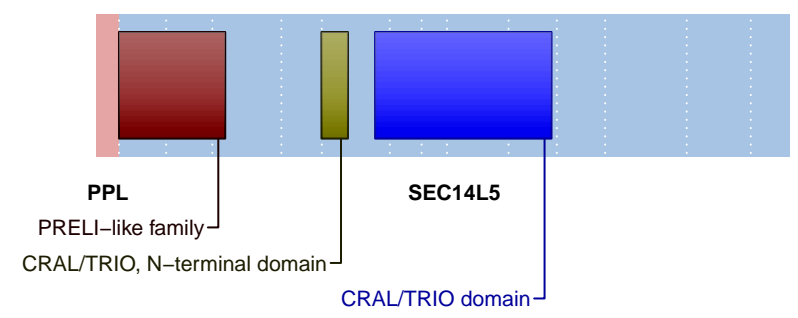

**SUPPORTING READ COUNT**

Split reads = 1  
Discordant mates = 0

- translocation
- duplication
- deletion
- inversion

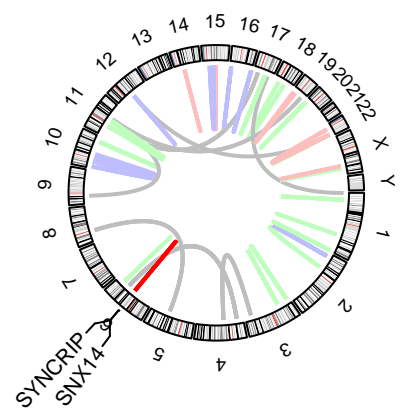
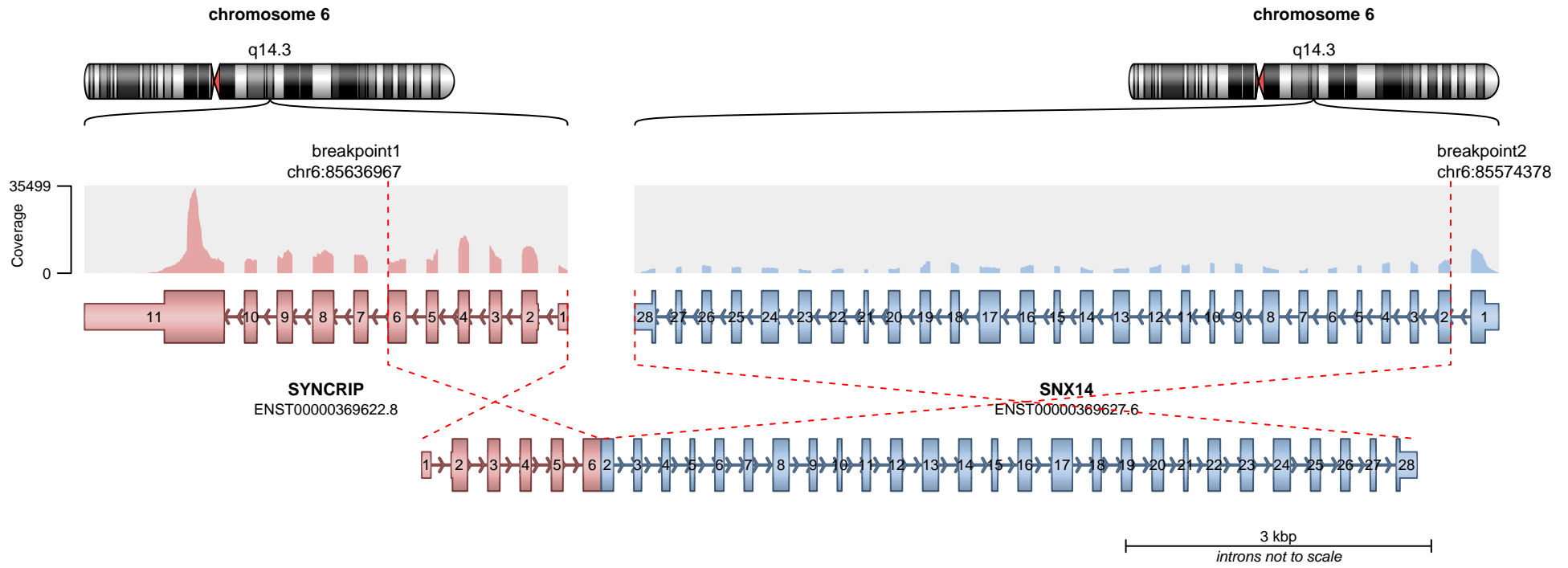

— translocation — deletion  
— duplication — inversion

**RETAINED PROTEIN DOMAINS**  
reading frame unclear

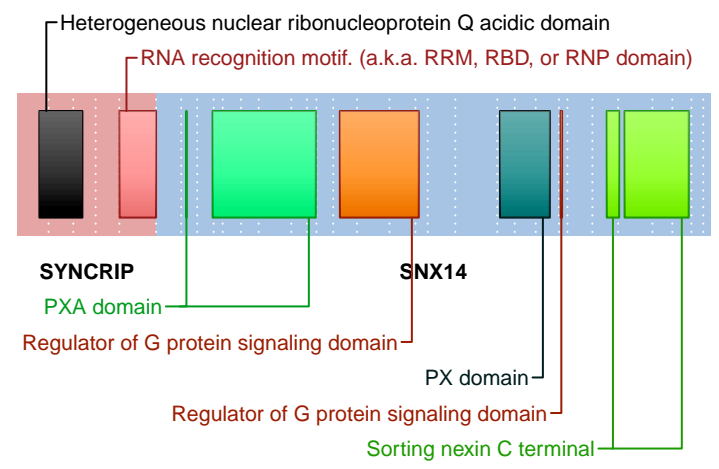

**SUPPORTING READ COUNT**

Split reads = 93  
Discordant mates = 5

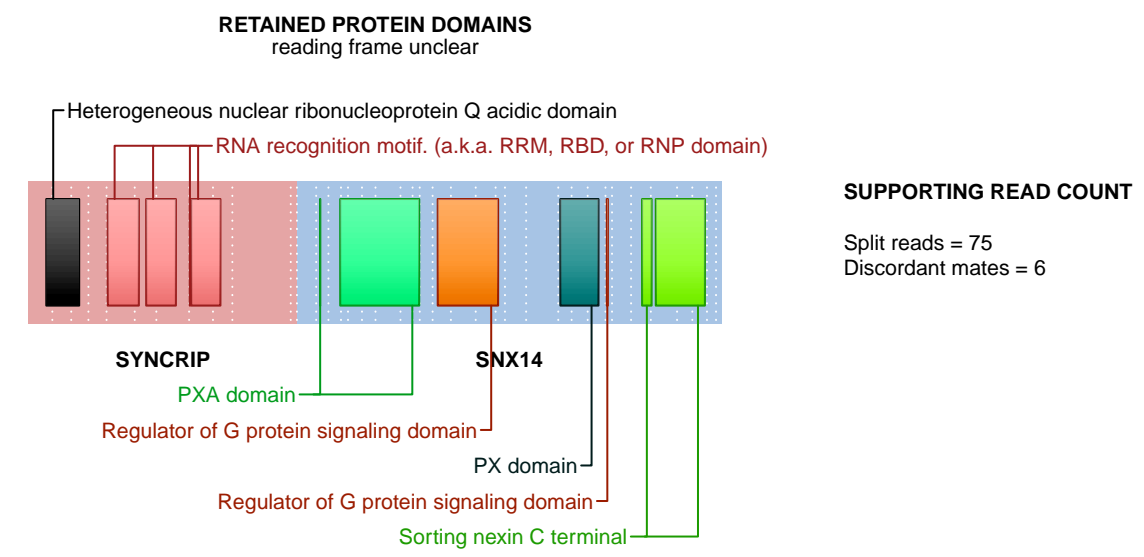
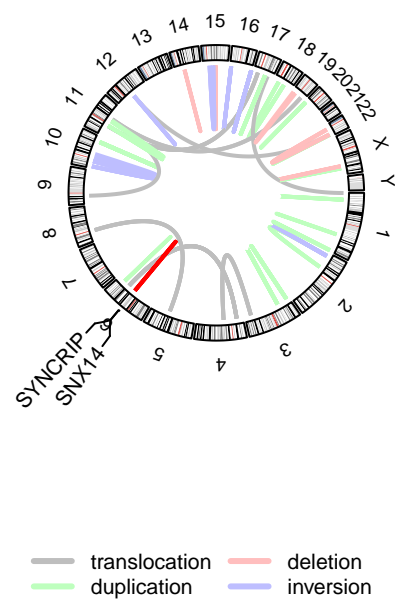
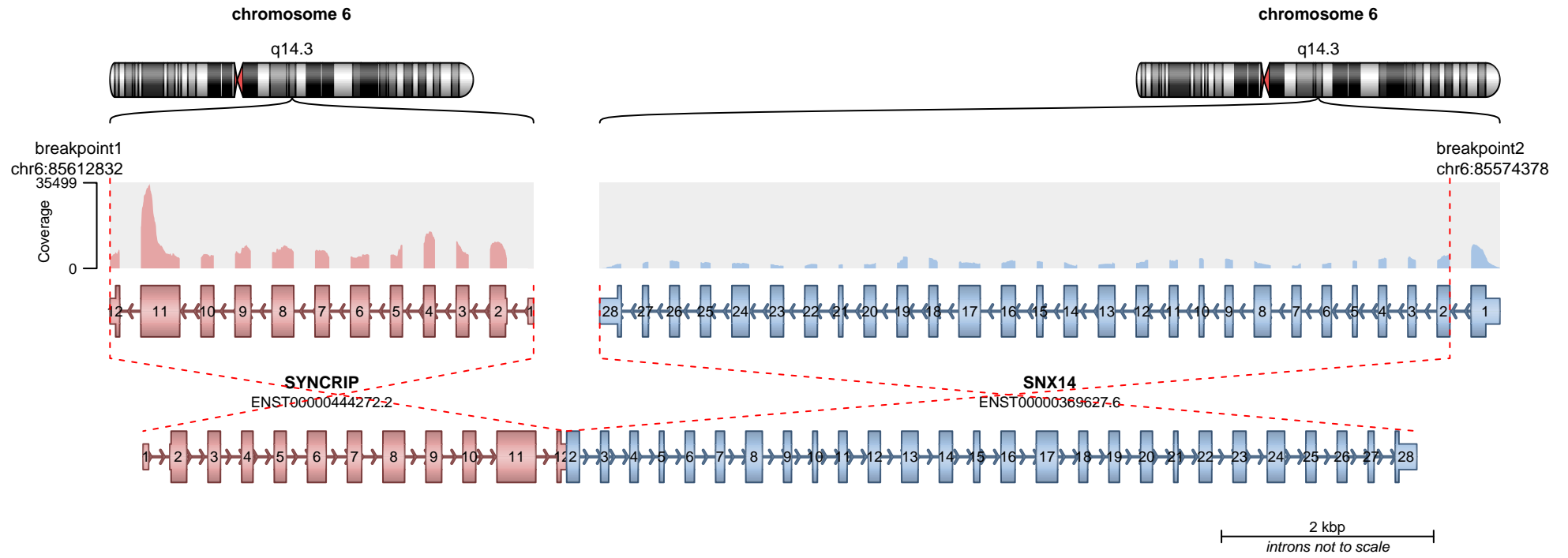

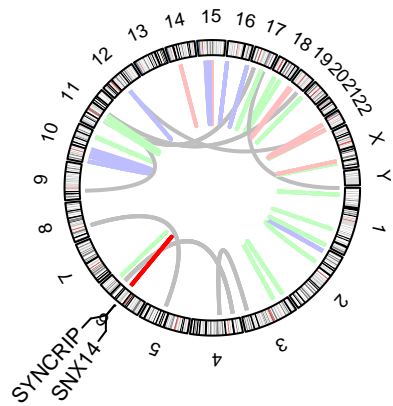
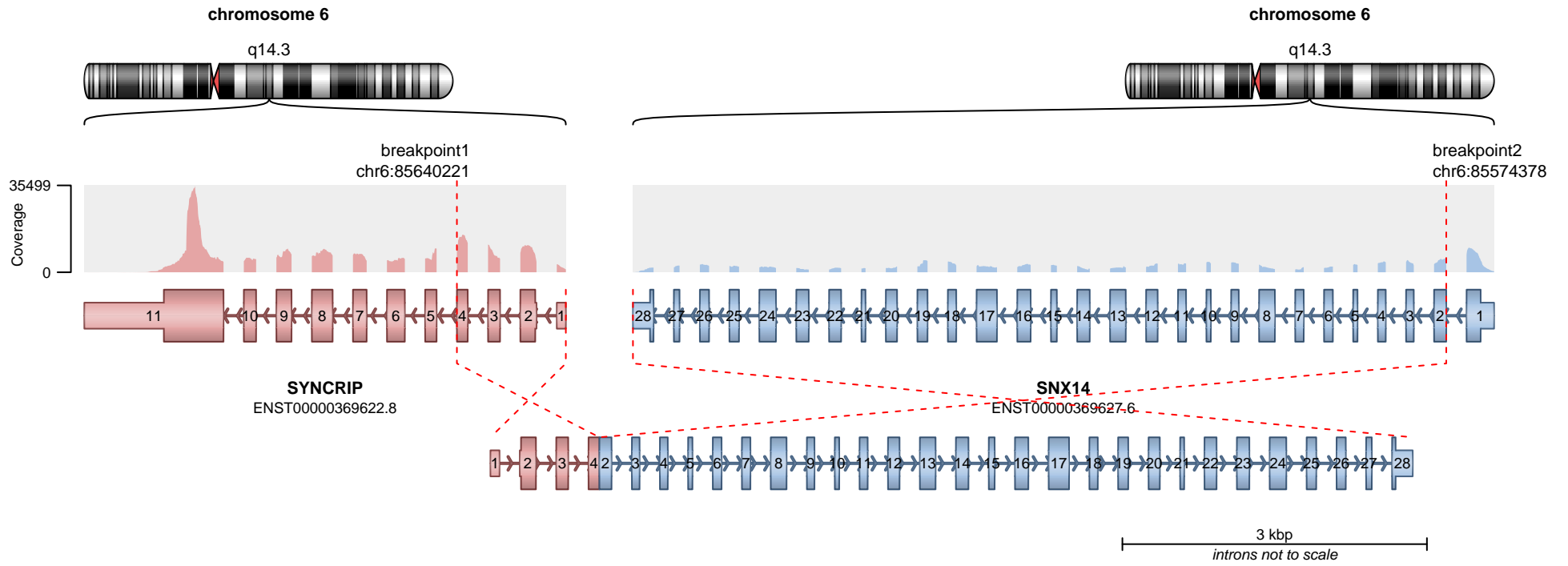

— translocation — deletion  
— duplication — inversion

**RETAINED PROTEIN DOMAINS**  
reading frame unclear

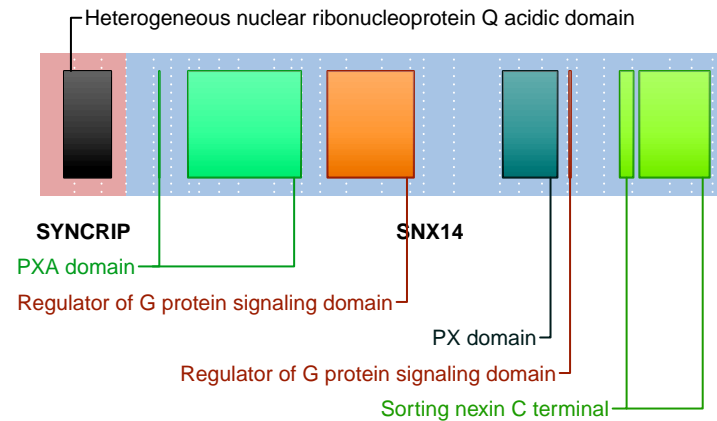

**SUPPORTING READ COUNT**

Split reads = 1  
Discordant mates = 0

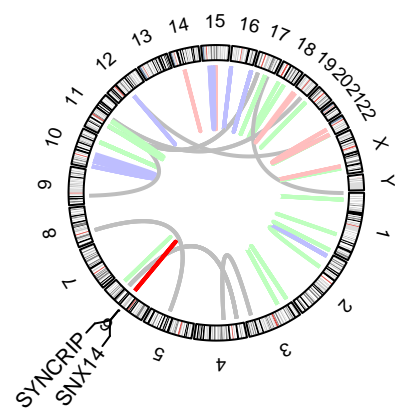
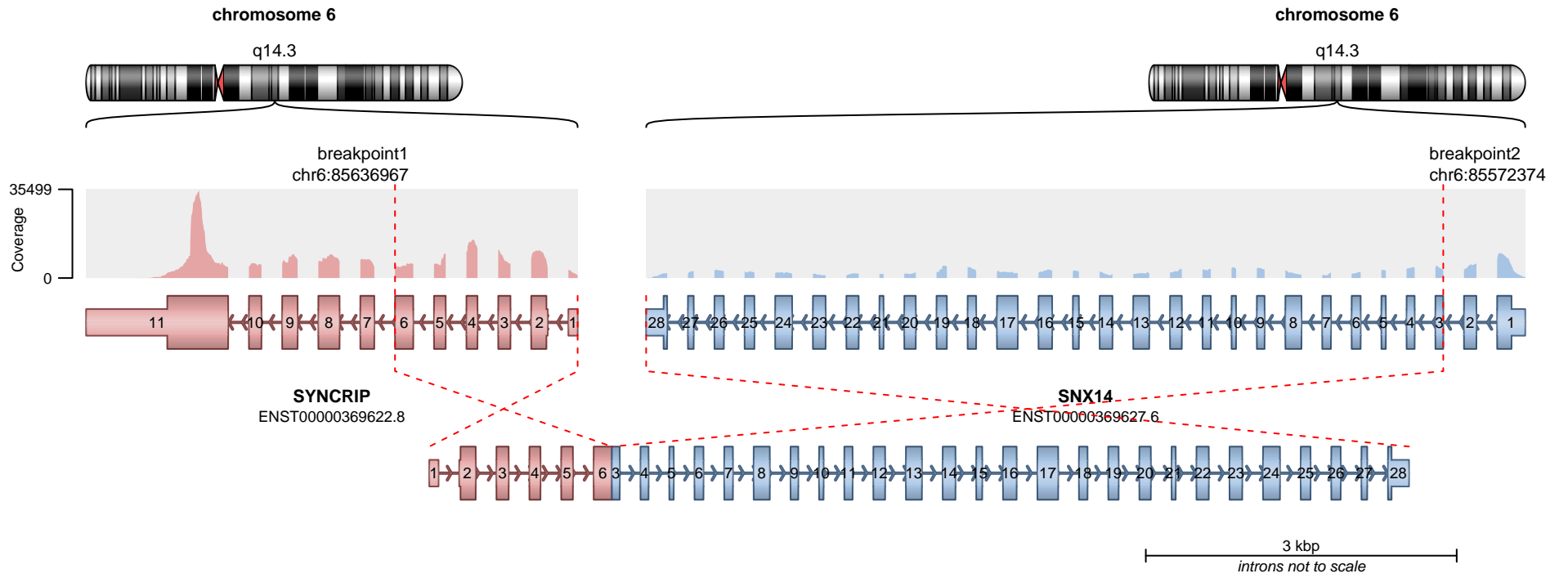

— translocation — deletion  
— duplication — inversion

**RETAINED PROTEIN DOMAINS**  
reading frame unclear

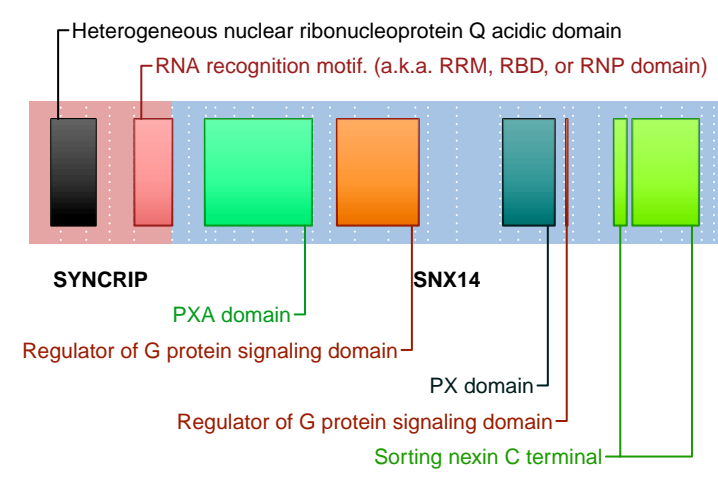

**SUPPORTING READ COUNT**

Split reads = 1  
Discordant mates = 0

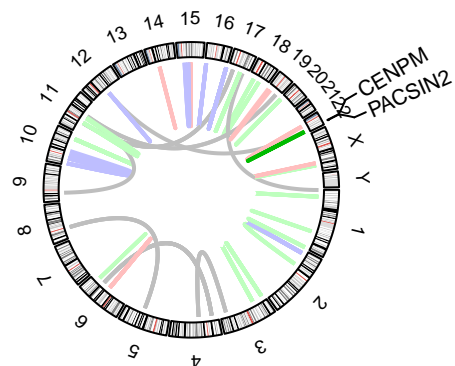
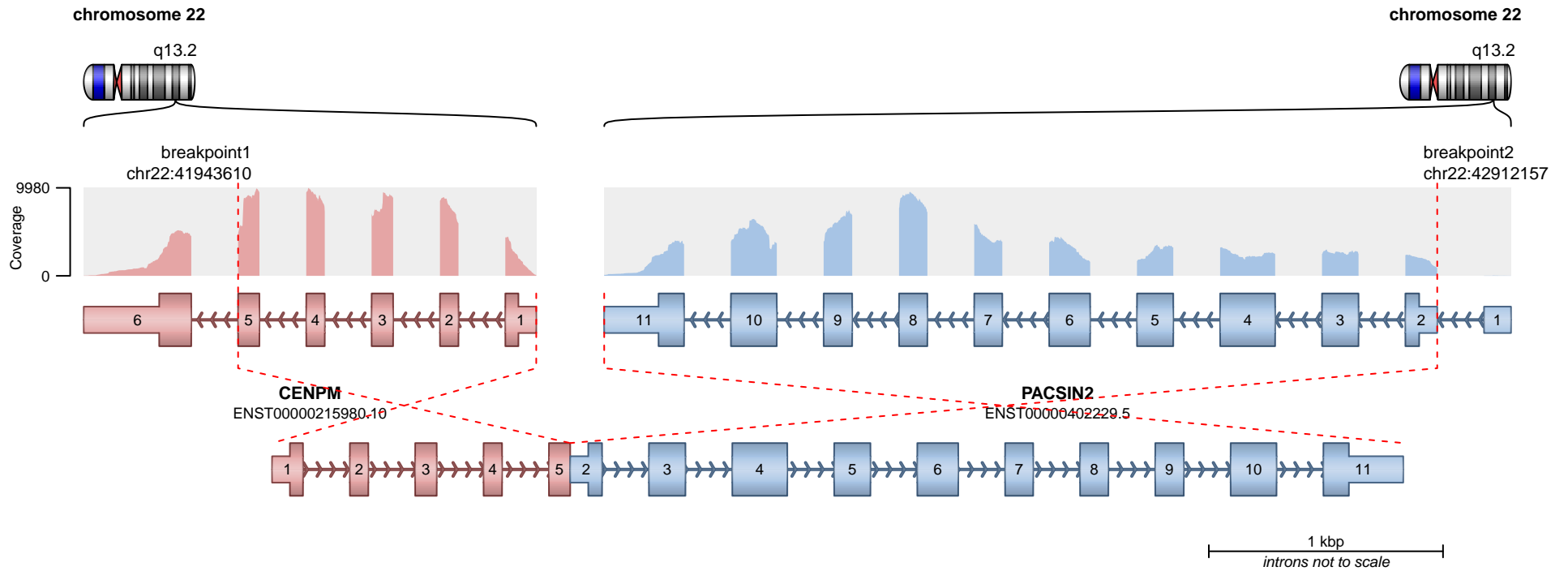

**RETAINED PROTEIN DOMAINS**  
reading frame unclear

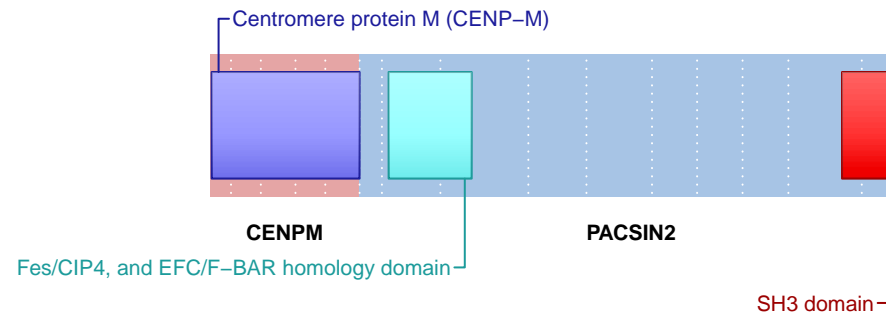

**SUPPORTING READ COUNT**

Split reads = 92  
Discordant mates = 7

— translocation    — deletion  
— duplication    — inversion

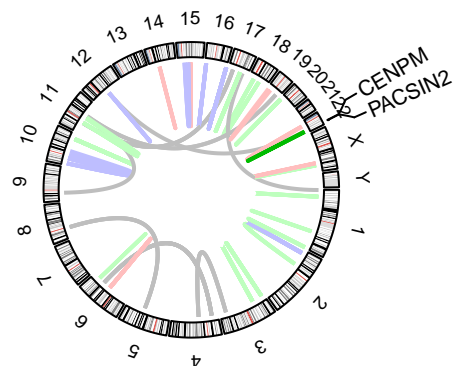
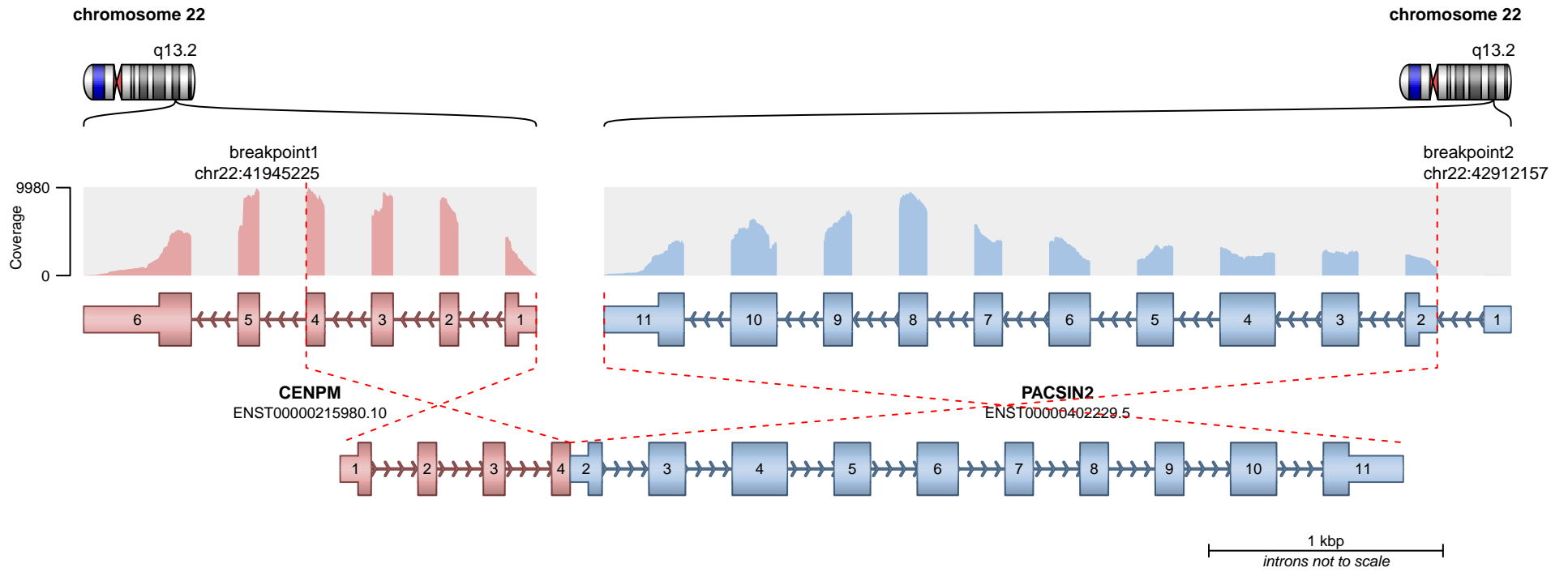

**RETAINED PROTEIN DOMAINS**  
reading frame unclear

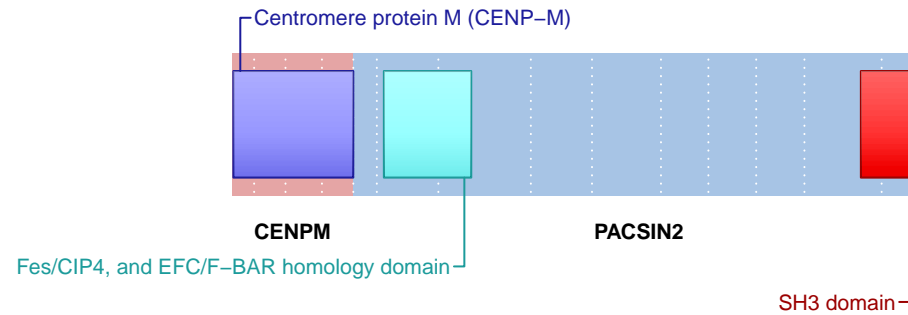

**SUPPORTING READ COUNT**

Split reads = 37  
Discordant mates = 1

— translocation    — deletion  
— duplication    — inversion

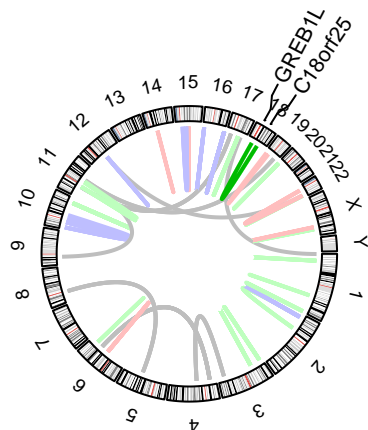
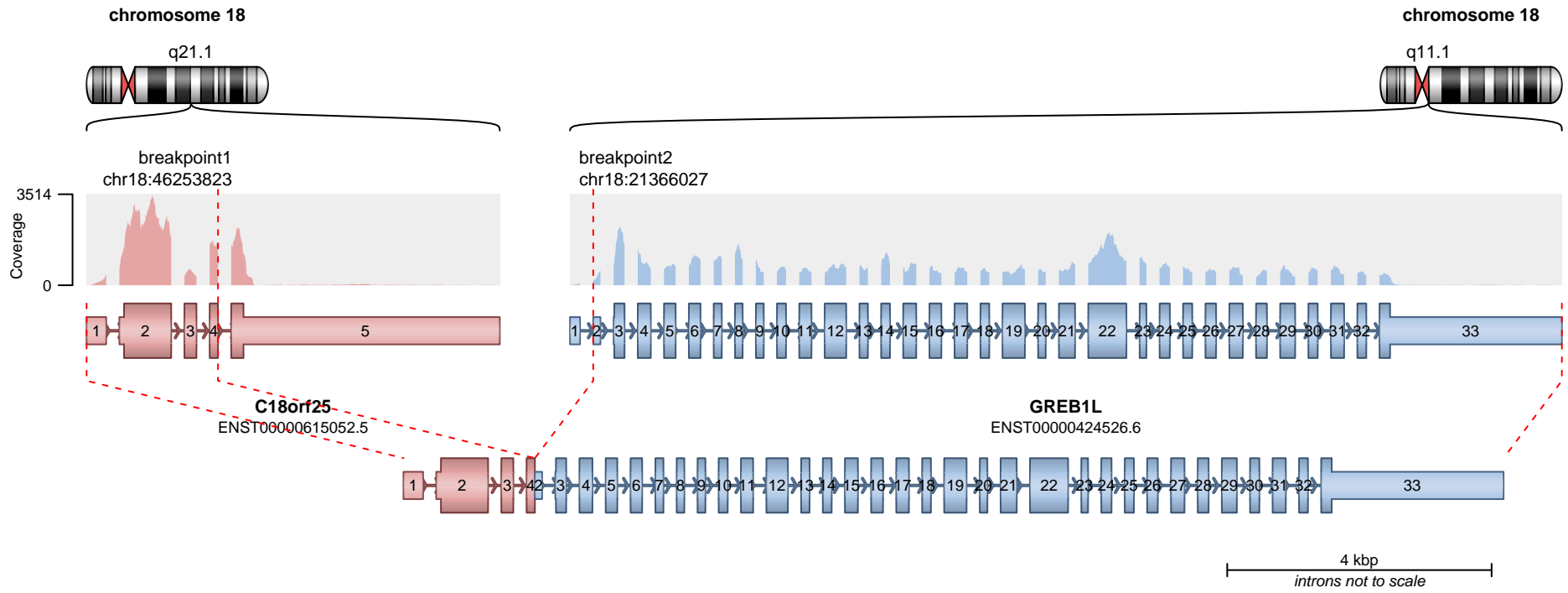

**RETAINED PROTEIN DOMAINS**  
reading frame unclear

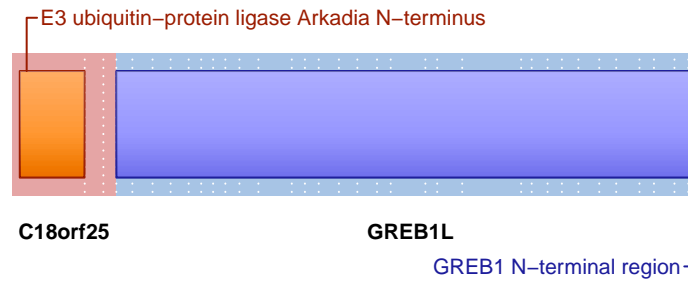

**SUPPORTING READ COUNT**

Split reads = 82  
Discordant mates = 4

— translocation — deletion  
— duplication — inversion

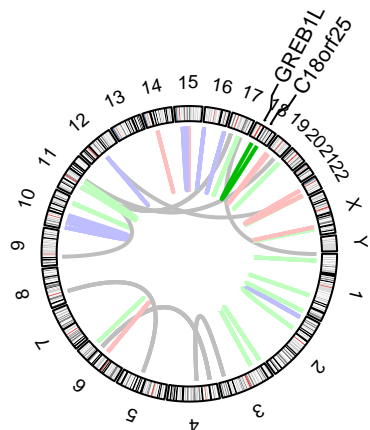
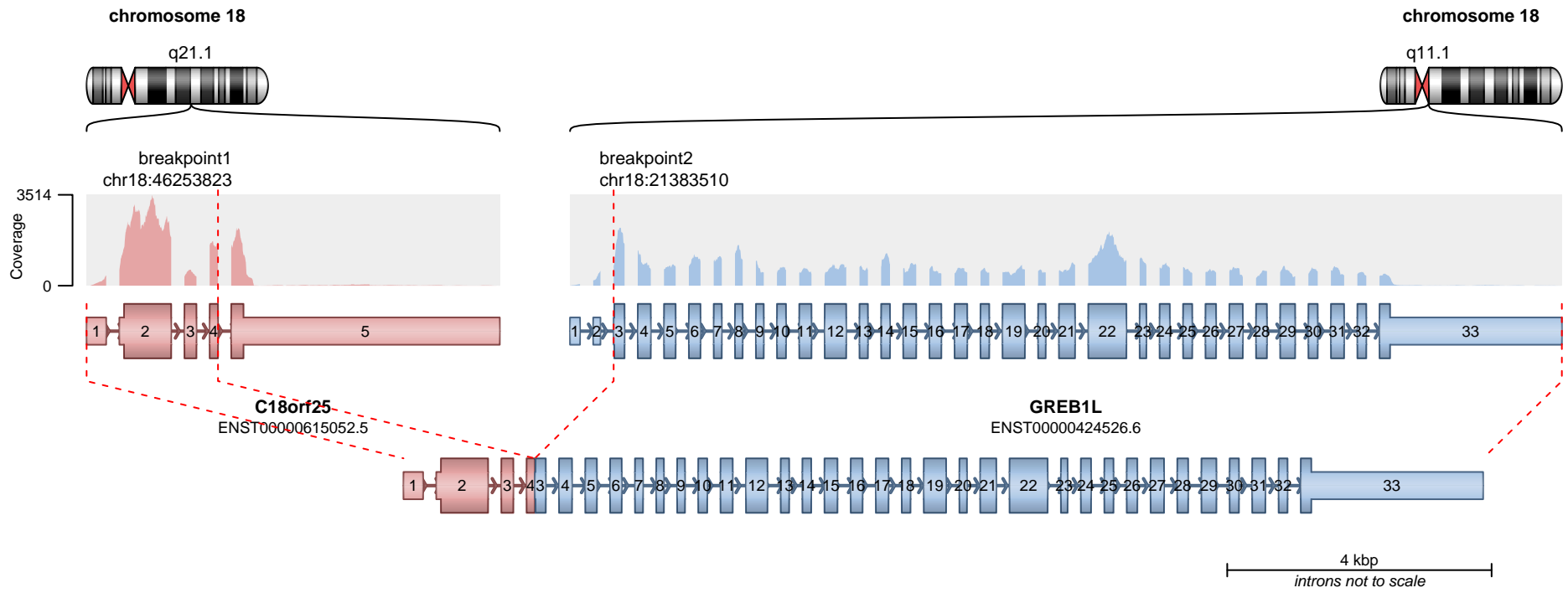

**RETAINED PROTEIN DOMAINS**  
reading frame unclear

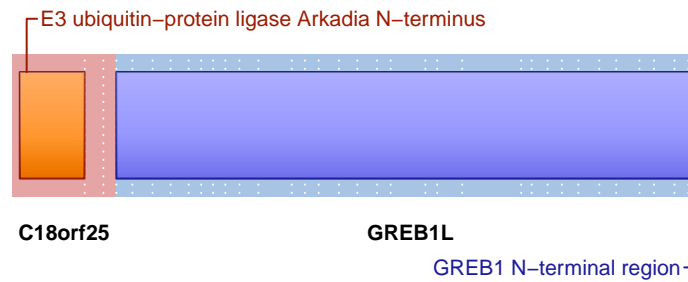

**SUPPORTING READ COUNT**

Split reads = 2  
Discordant mates = 2

— translocation — deletion  
— duplication — inversion

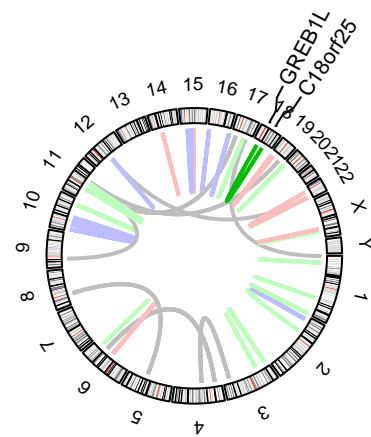
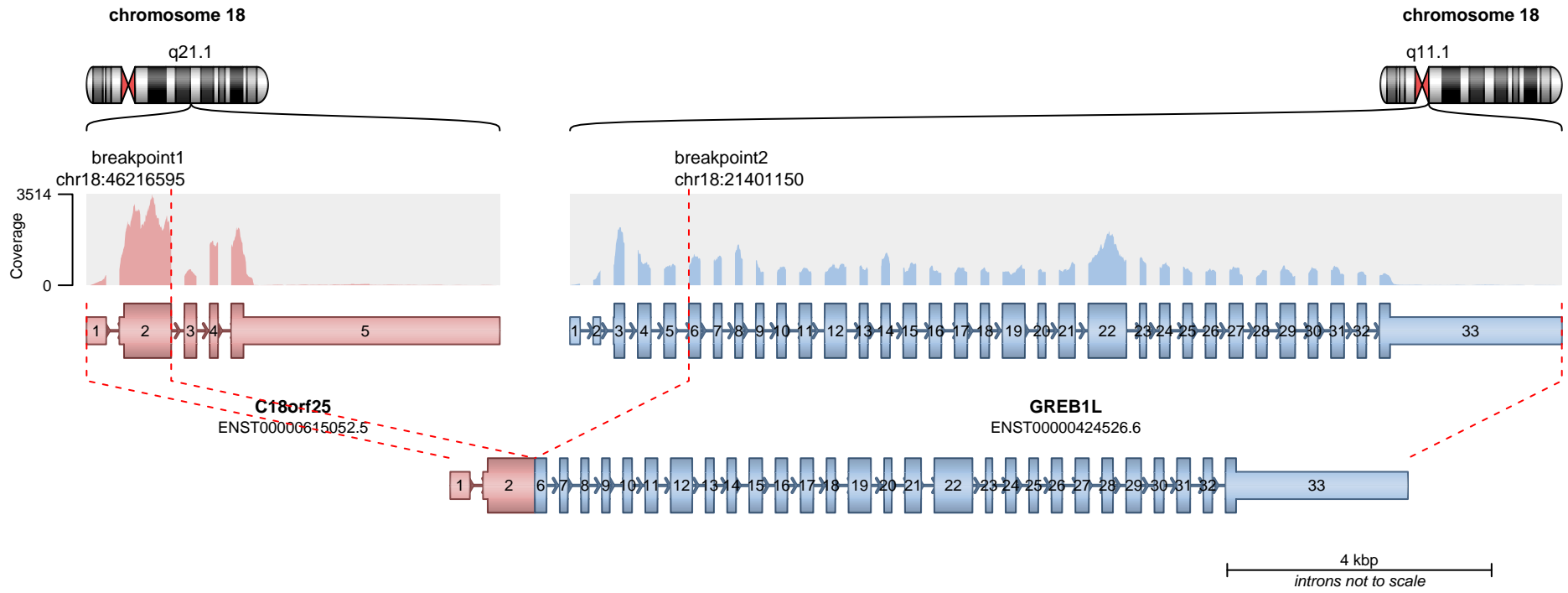

**RETAINED PROTEIN DOMAINS**  
reading frame unclear

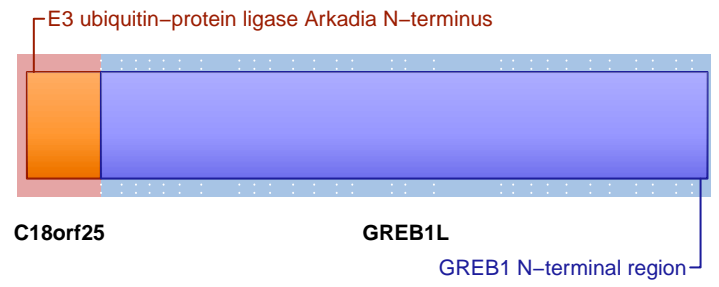

**SUPPORTING READ COUNT**

Split reads = 1  
Discordant mates = 0

- translocation
- duplication
- deletion
- inversion

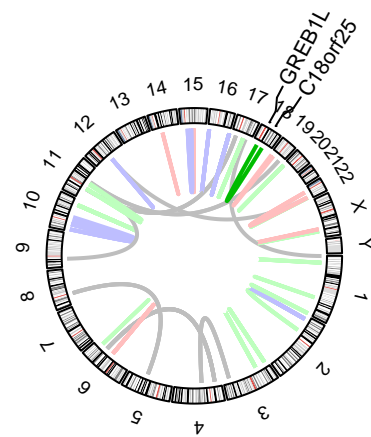
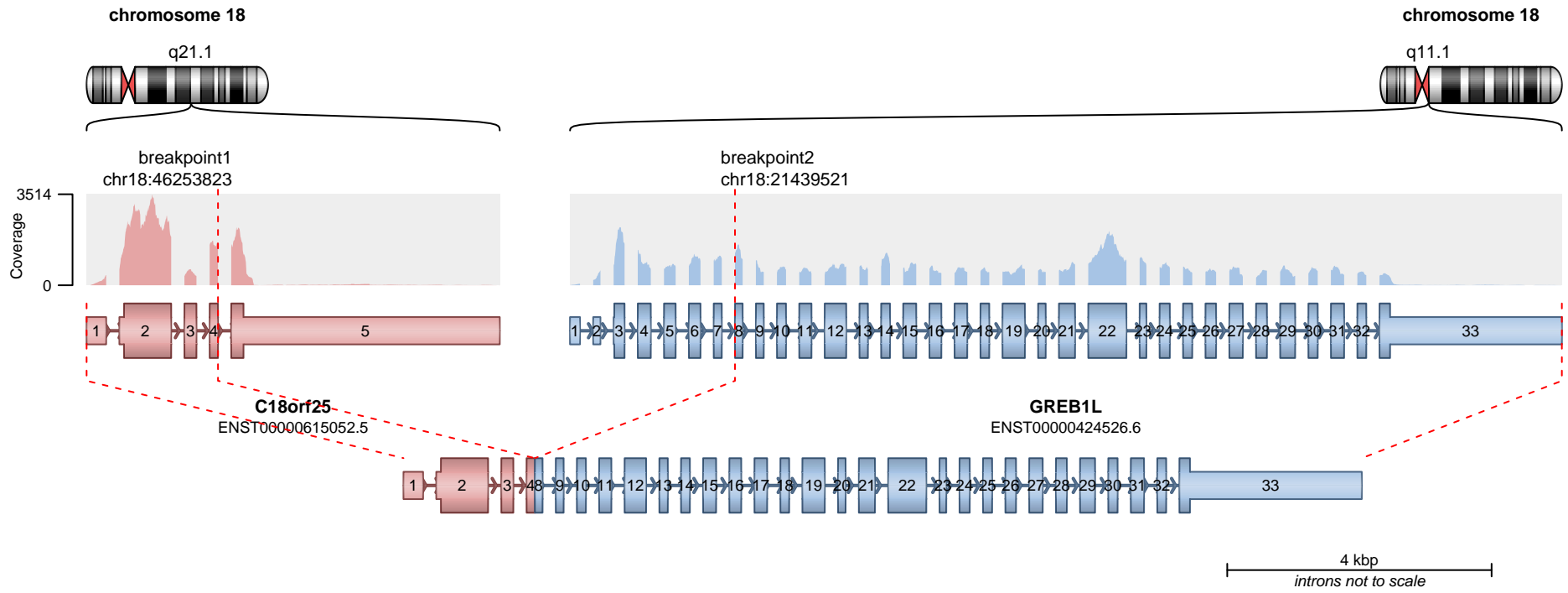

**RETAINED PROTEIN DOMAINS**  
reading frame unclear

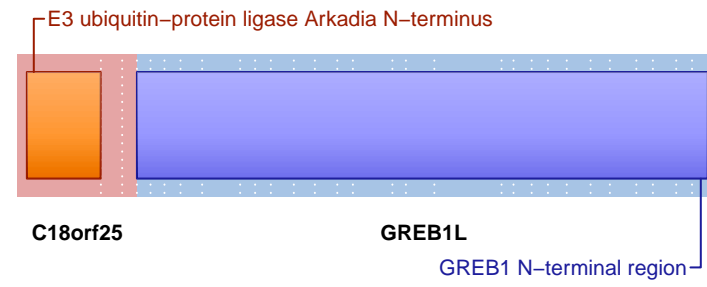

**SUPPORTING READ COUNT**

Split reads = 1  
Discordant mates = 0

— translocation    — deletion  
— duplication    — inversion

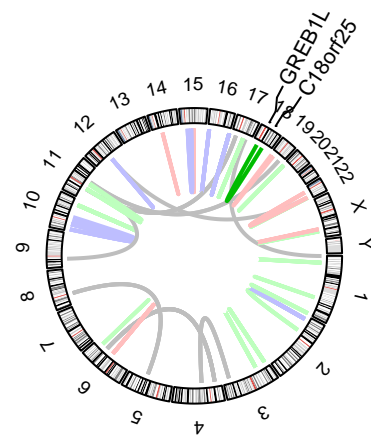
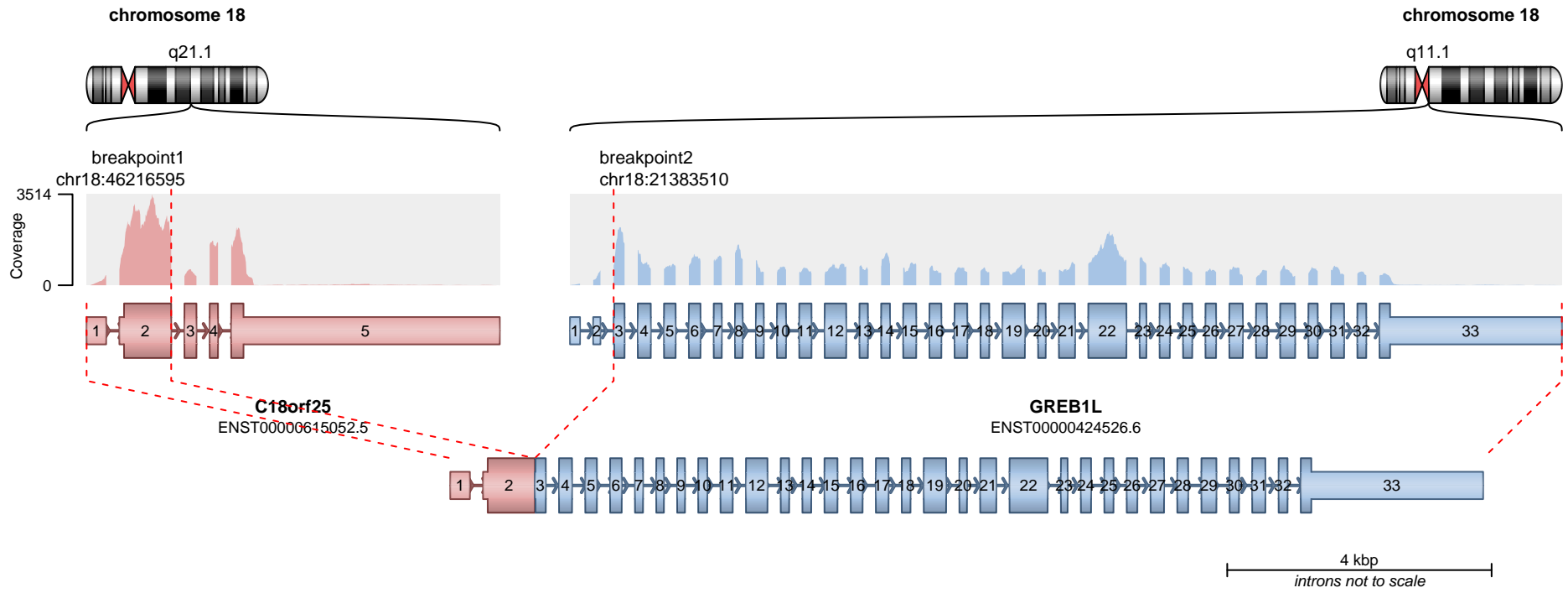

**RETAINED PROTEIN DOMAINS**  
reading frame unclear

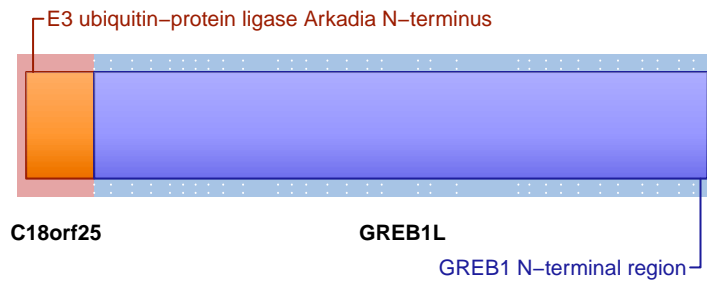

**SUPPORTING READ COUNT**

Split reads = 1  
Discordant mates = 0

- translocation
- duplication
- deletion
- inversion

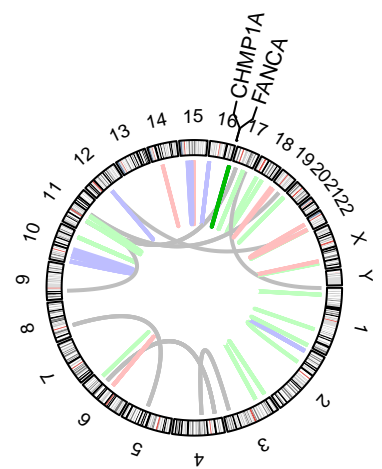
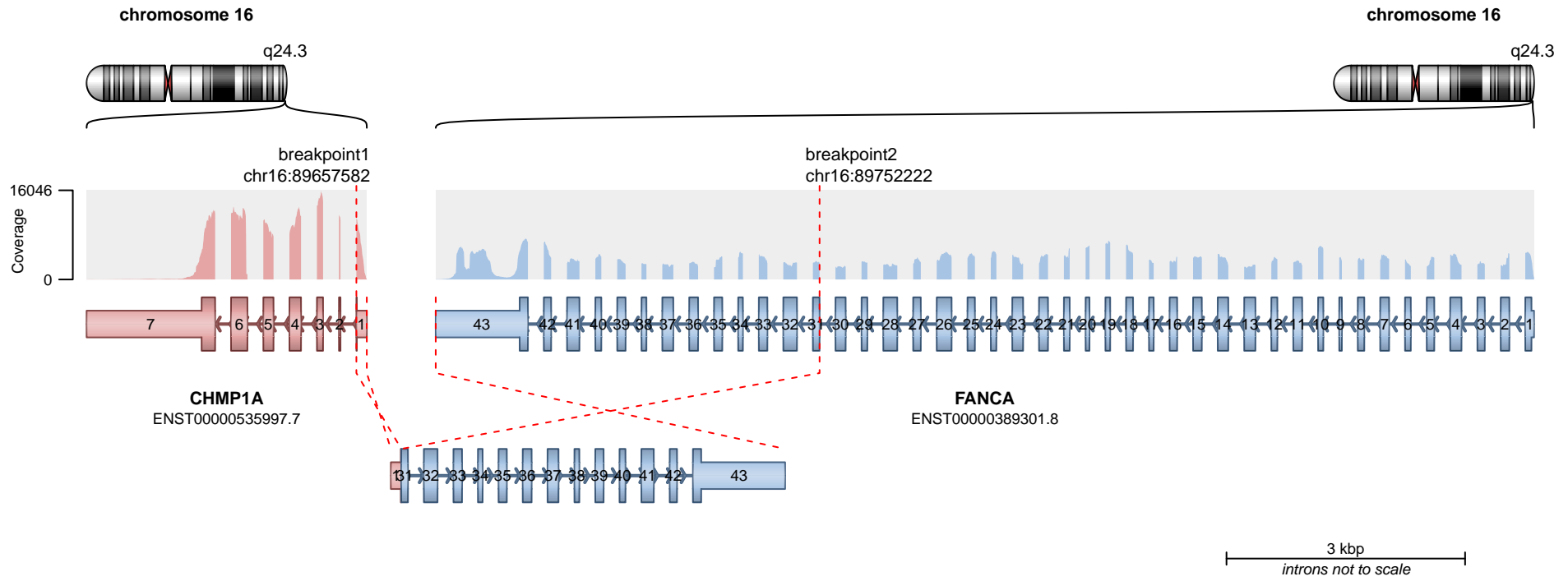

**RETAINED PROTEIN DOMAINS**  
reading frame unclear

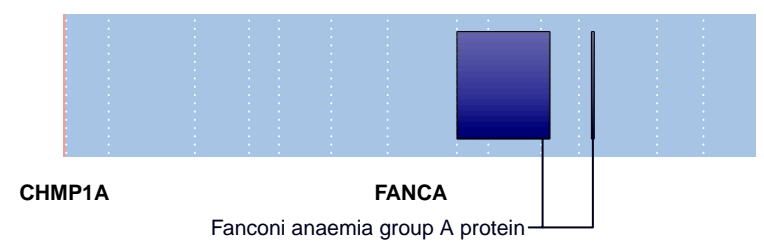

**SUPPORTING READ COUNT**

Split reads = 78  
Discordant mates = 0

- translocation
- duplication
- deletion
- inversion

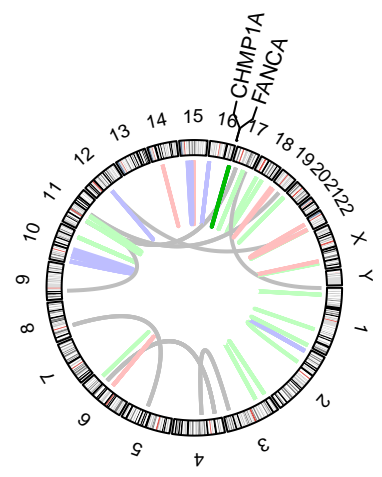
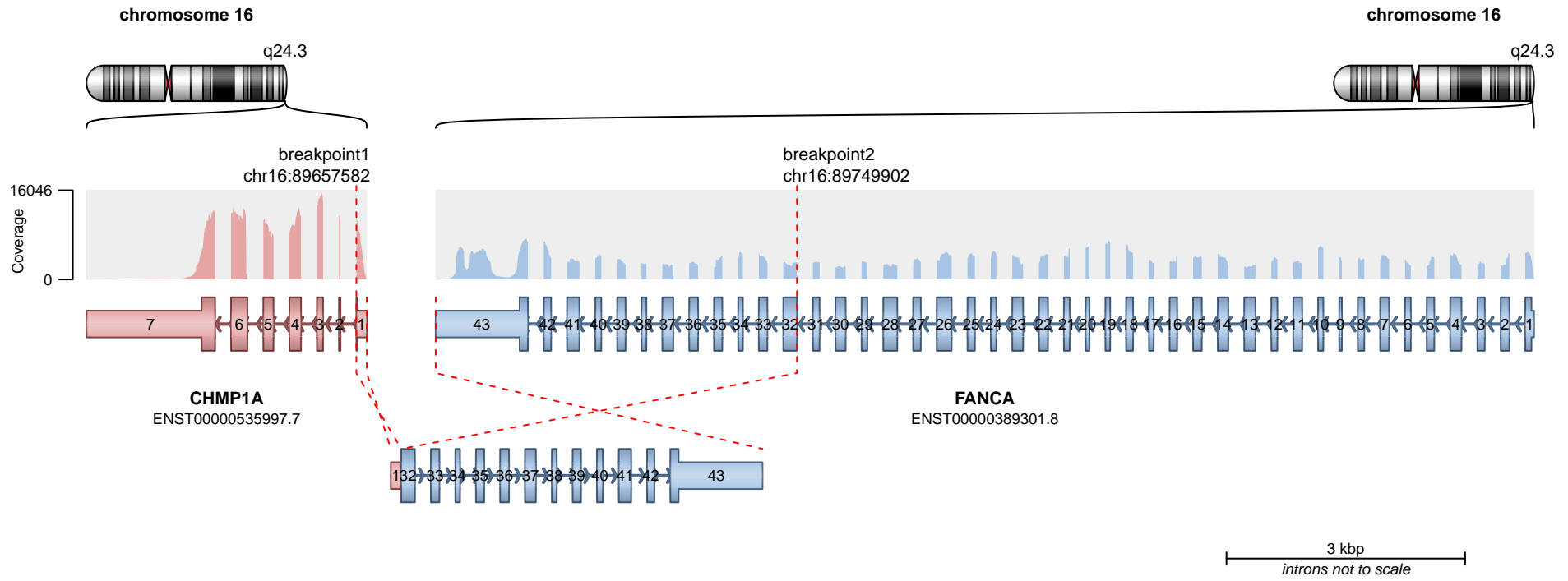

**RETAINED PROTEIN DOMAINS**  
reading frame unclear

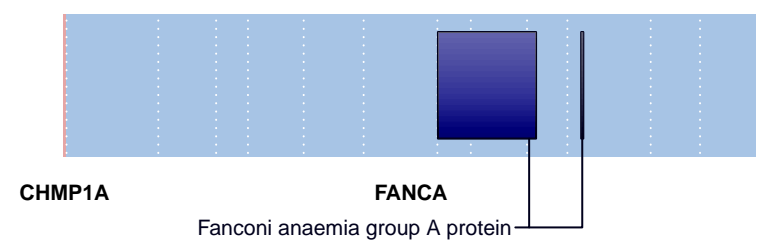

**SUPPORTING READ COUNT**

Split reads = 9  
Discordant mates = 0

- translocation
- duplication
- deletion
- inversion

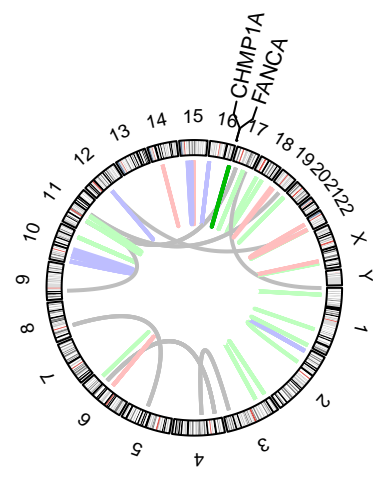
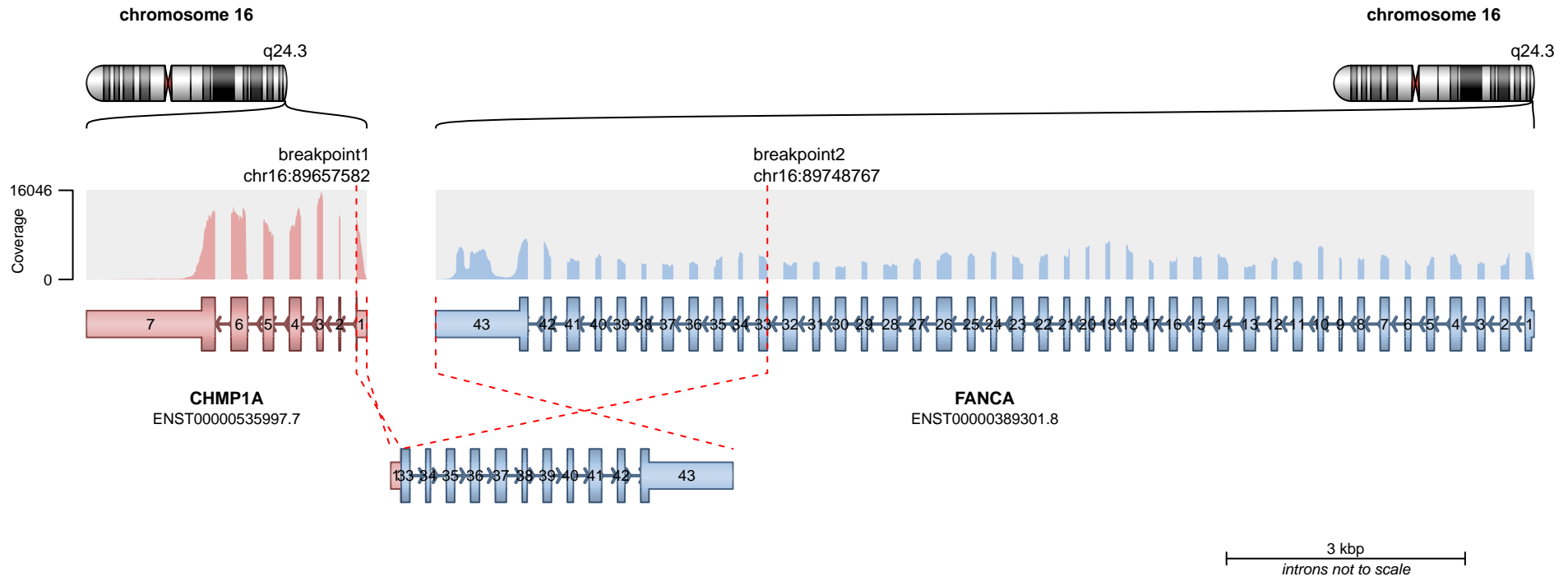

**RETAINED PROTEIN DOMAINS**  
reading frame unclear

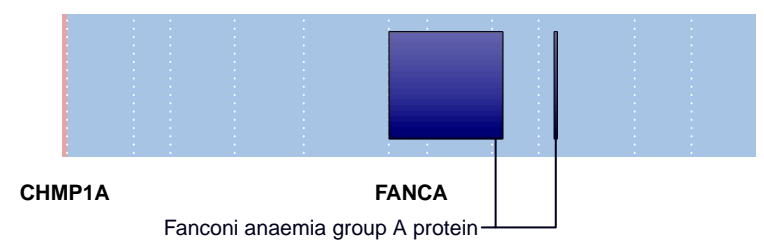

**SUPPORTING READ COUNT**

Split reads = 4  
Discordant mates = 0

- translocation
- duplication
- deletion
- inversion

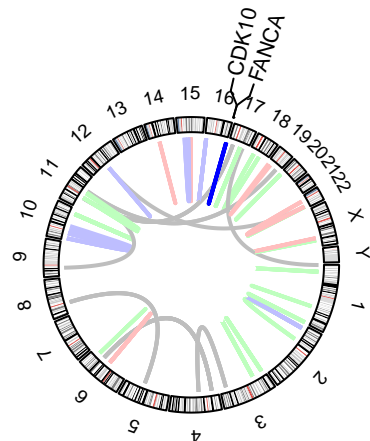
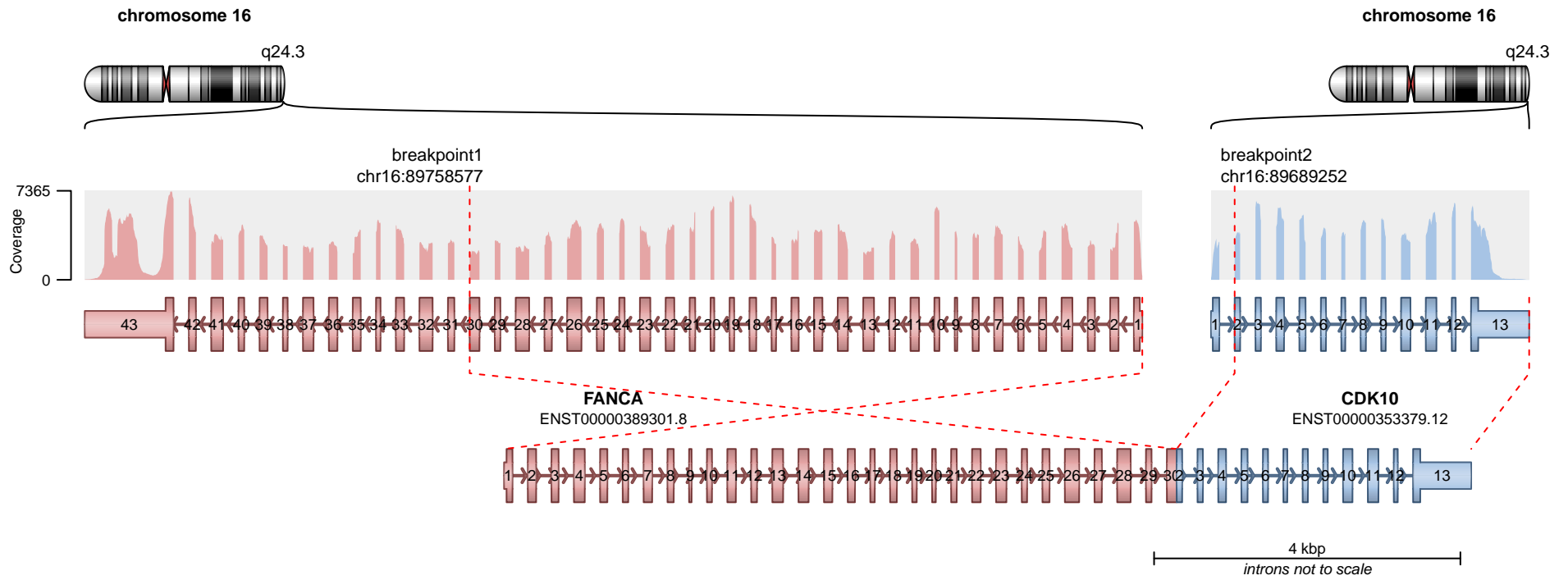

**RETAINED PROTEIN DOMAINS**  
reading frame unclear

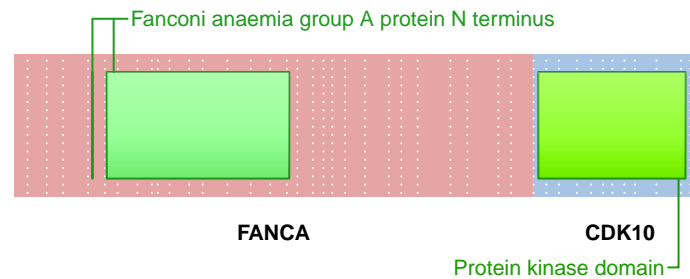

**SUPPORTING READ COUNT**

Split reads = 68  
Discordant mates = 2

- translocation
- duplication
- deletion
- inversion

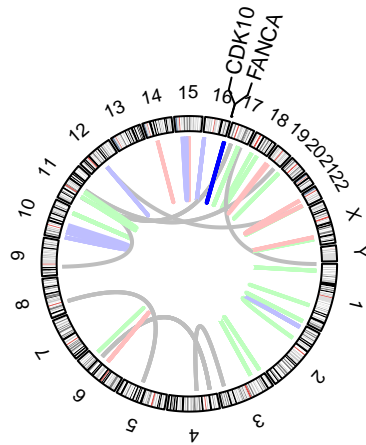
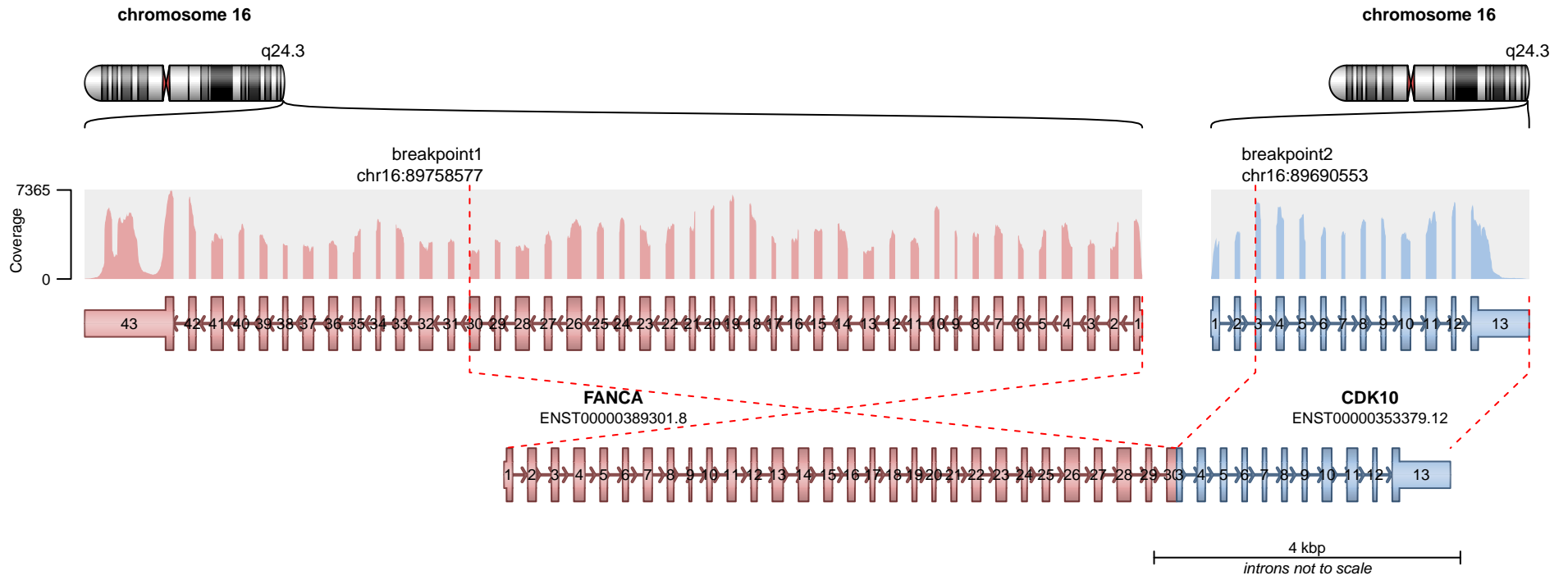

**RETAINED PROTEIN DOMAINS**  
reading frame unclear

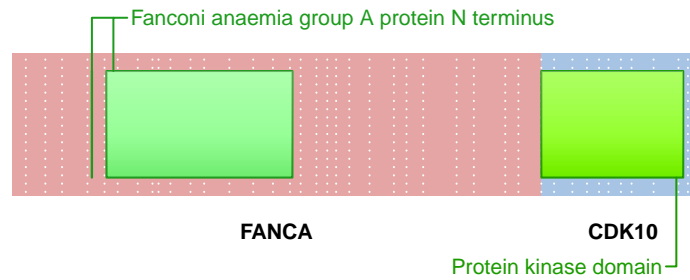

**SUPPORTING READ COUNT**

Split reads = 44  
Discordant mates = 1

- translocation
- duplication
- deletion
- inversion

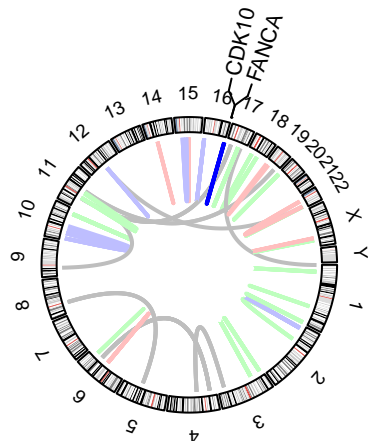
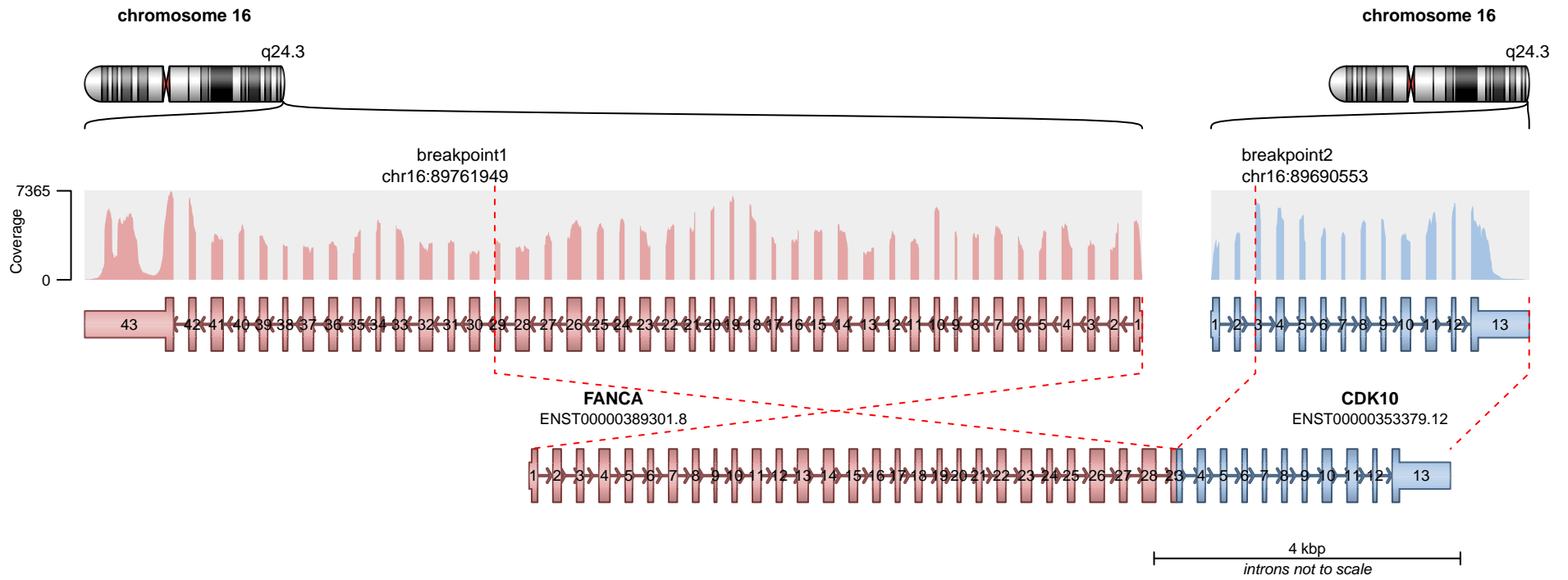

**RETAINED PROTEIN DOMAINS**  
reading frame unclear

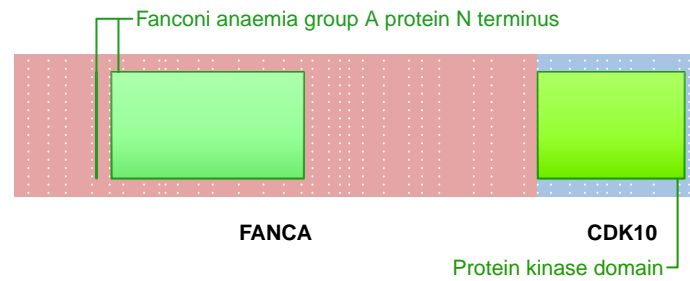

**SUPPORTING READ COUNT**

Split reads = 8  
Discordant mates = 0

- translocation
- duplication
- deletion
- inversion

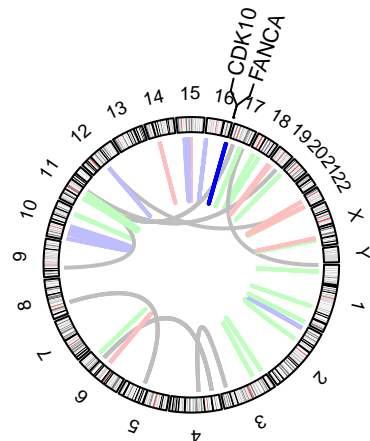
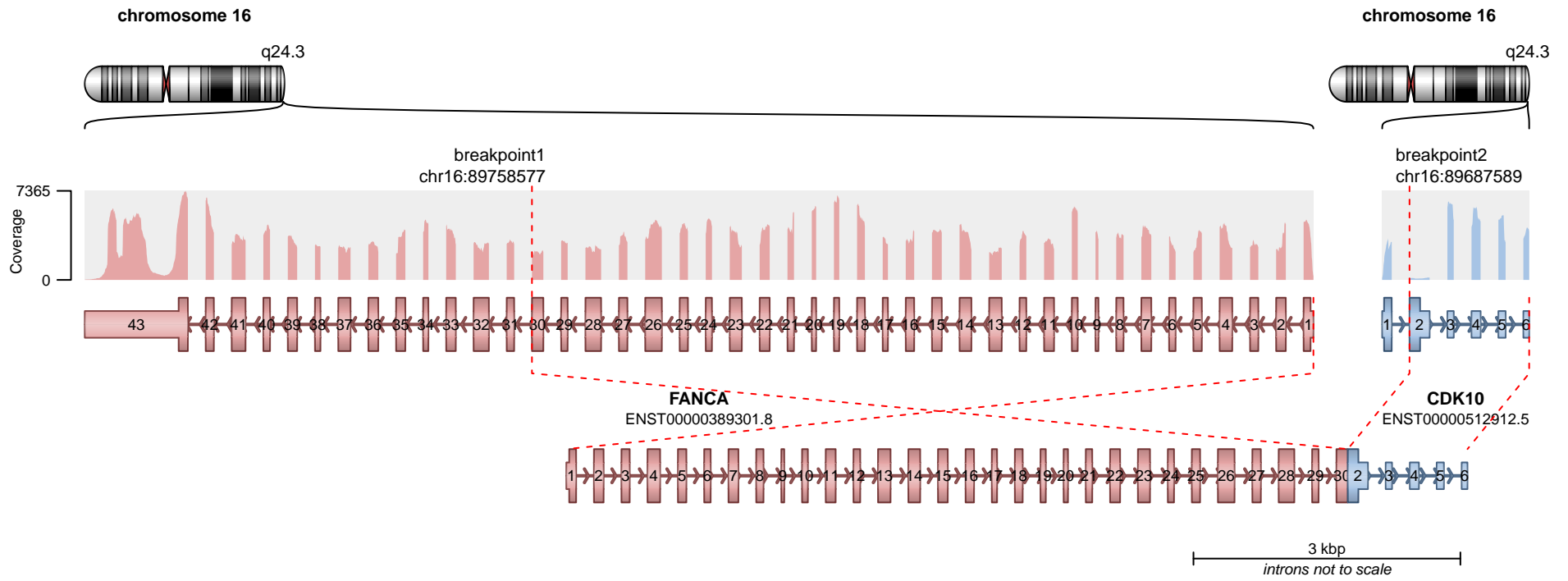

**RETAINED PROTEIN DOMAINS**  
reading frame unclear

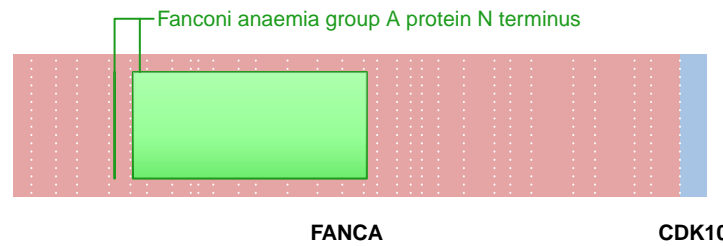

**SUPPORTING READ COUNT**

Split reads = 2  
Discordant mates = 2

- translocation
- duplication
- deletion
- inversion

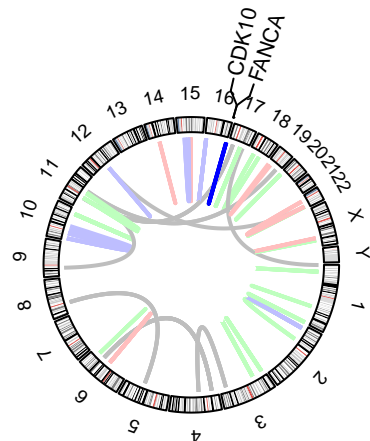
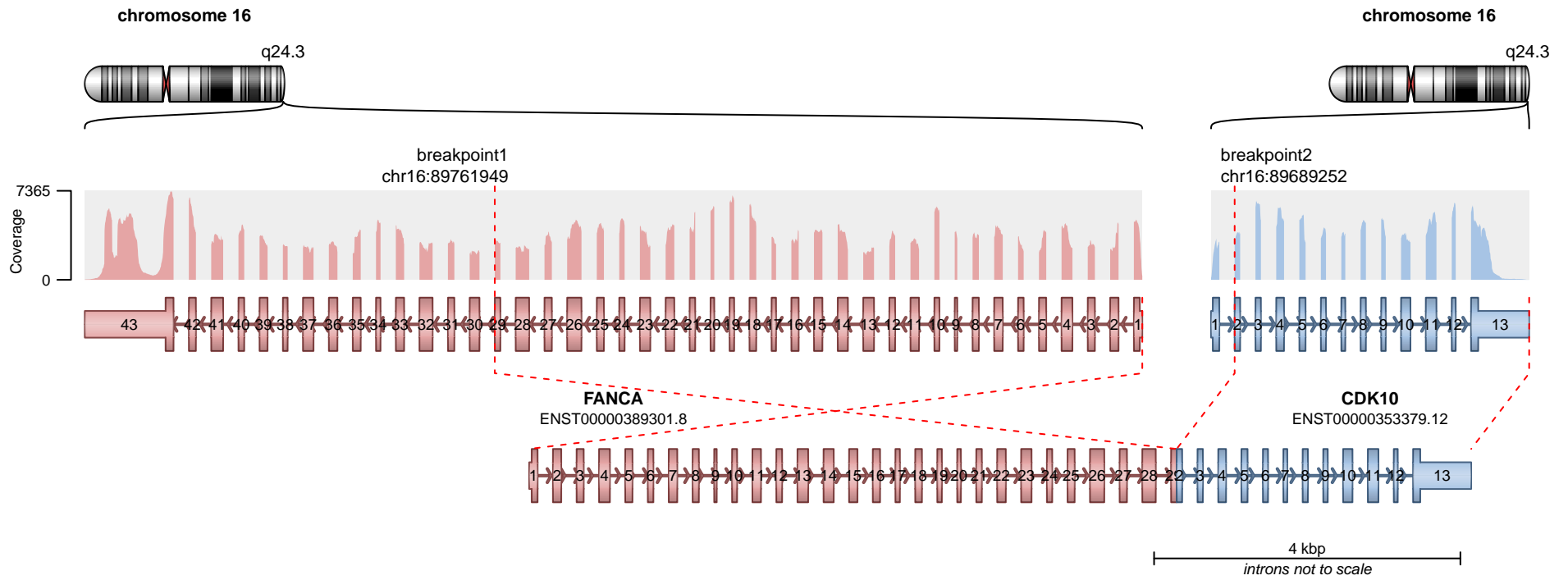

**RETAINED PROTEIN DOMAINS**  
reading frame unclear

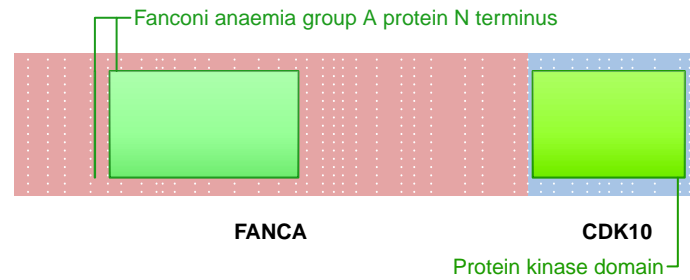

**SUPPORTING READ COUNT**

Split reads = 2  
Discordant mates = 0

- translocation
- duplication
- deletion
- inversion

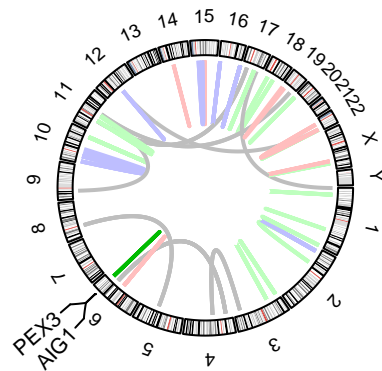
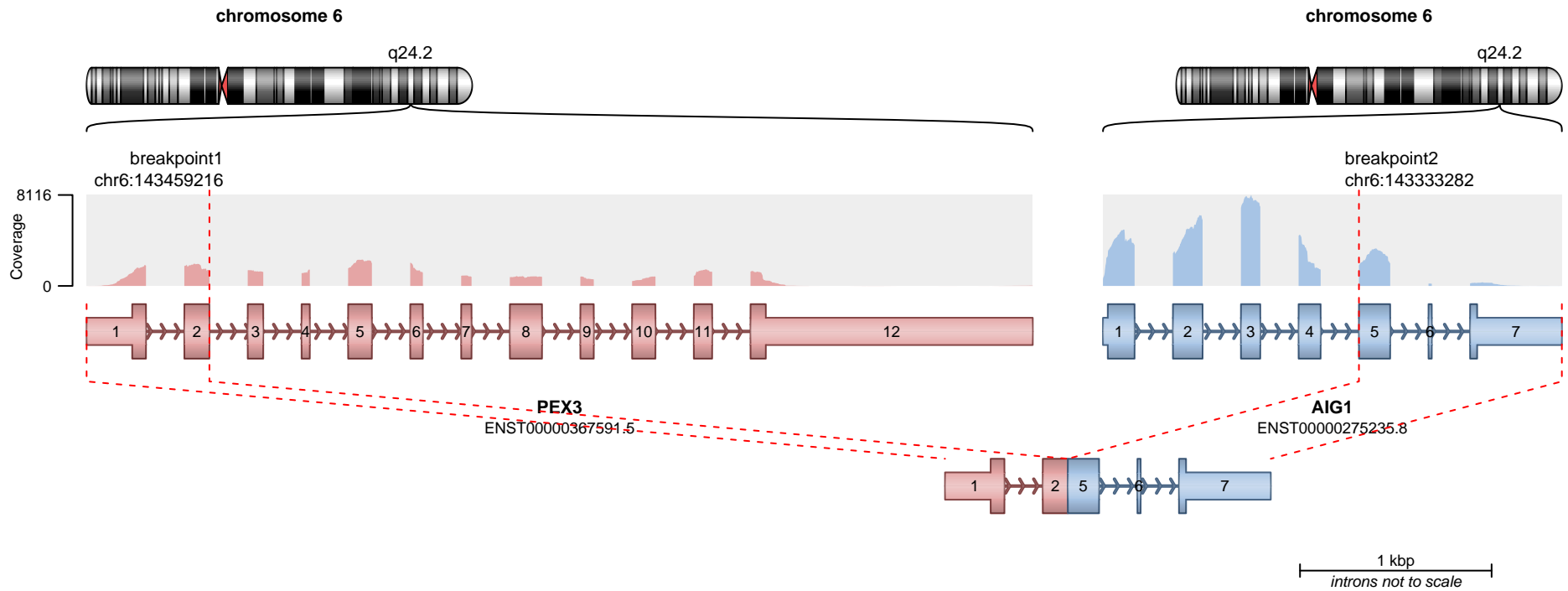

**RETAINED PROTEIN DOMAINS**  
reading frame unclear

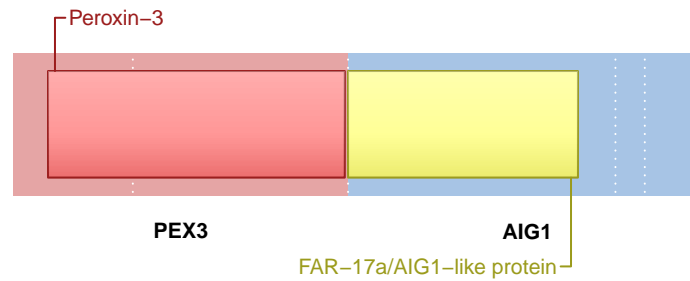

**SUPPORTING READ COUNT**

Split reads = 67  
Discordant mates = 0

— translocation    — deletion  
— duplication    — inversion

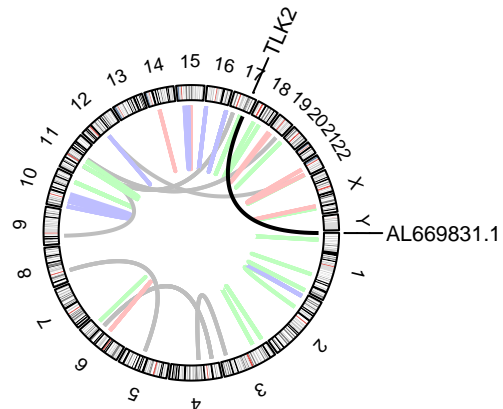
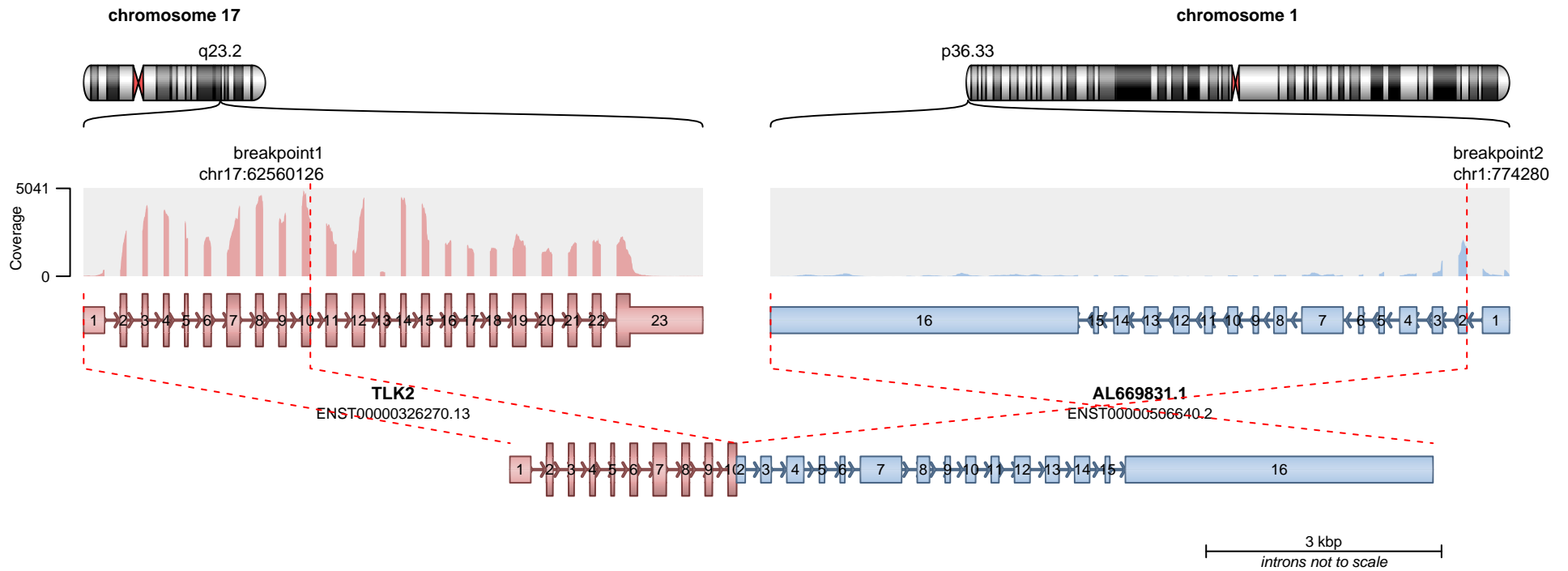

No protein domains retained in fusion.

**SUPPORTING READ COUNT**

Split reads = 64  
Discordant mates = 0

- translocation
- duplication
- deletion
- inversion

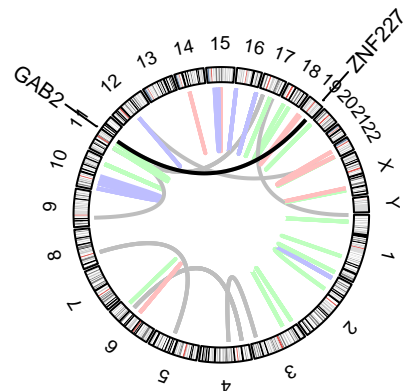
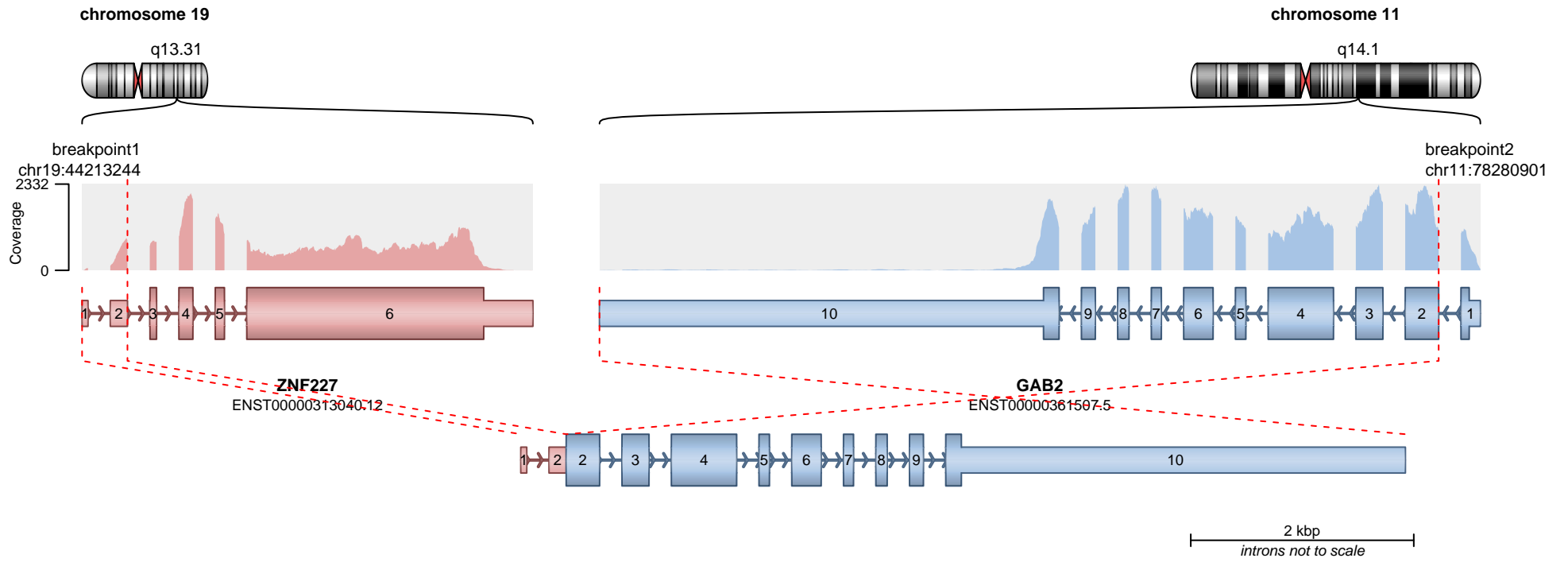

**RETAINED PROTEIN DOMAINS**  
reading frame unclear

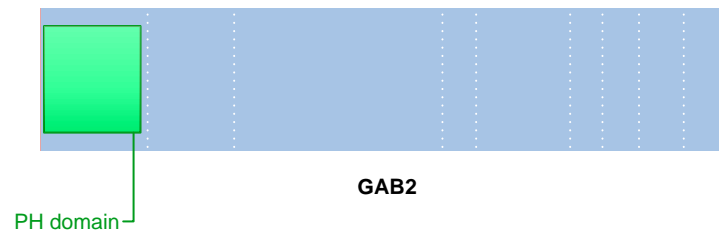

**SUPPORTING READ COUNT**

Split reads = 62  
Discordant mates = 3

— translocation    — deletion  
— duplication    — inversion

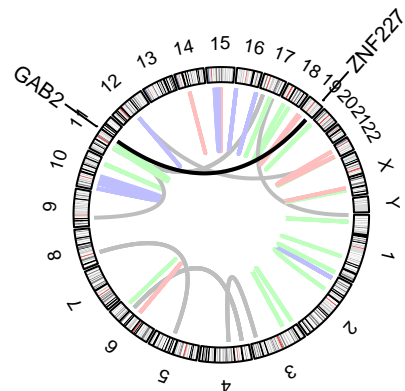
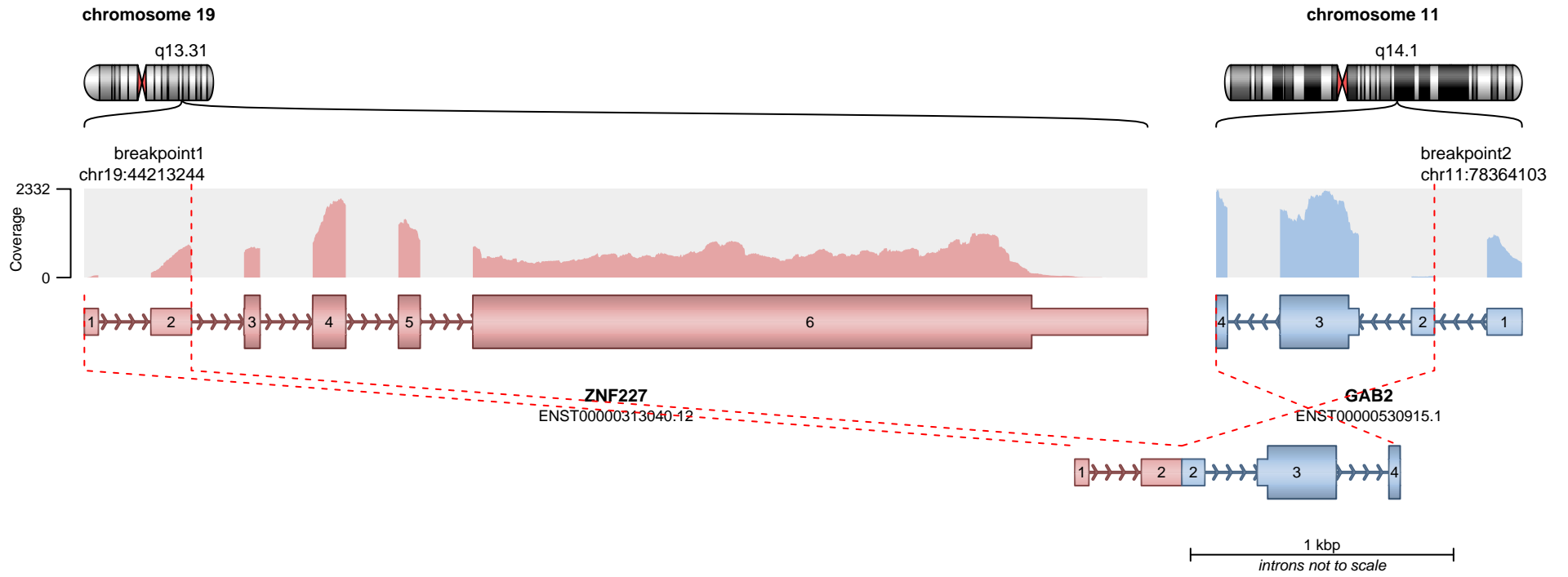

**RETAINED PROTEIN DOMAINS**  
reading frame unclear

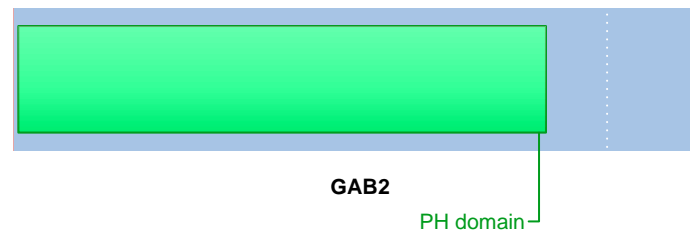

**SUPPORTING READ COUNT**

Split reads = 2  
Discordant mates = 3

— translocation    — deletion  
— duplication    — inversion

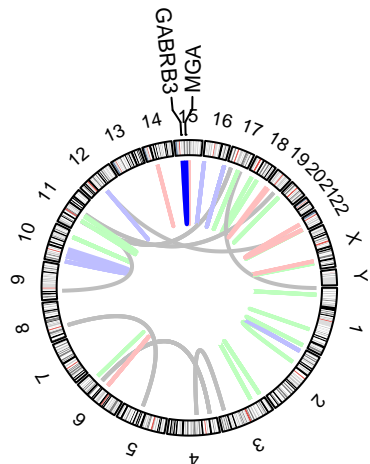
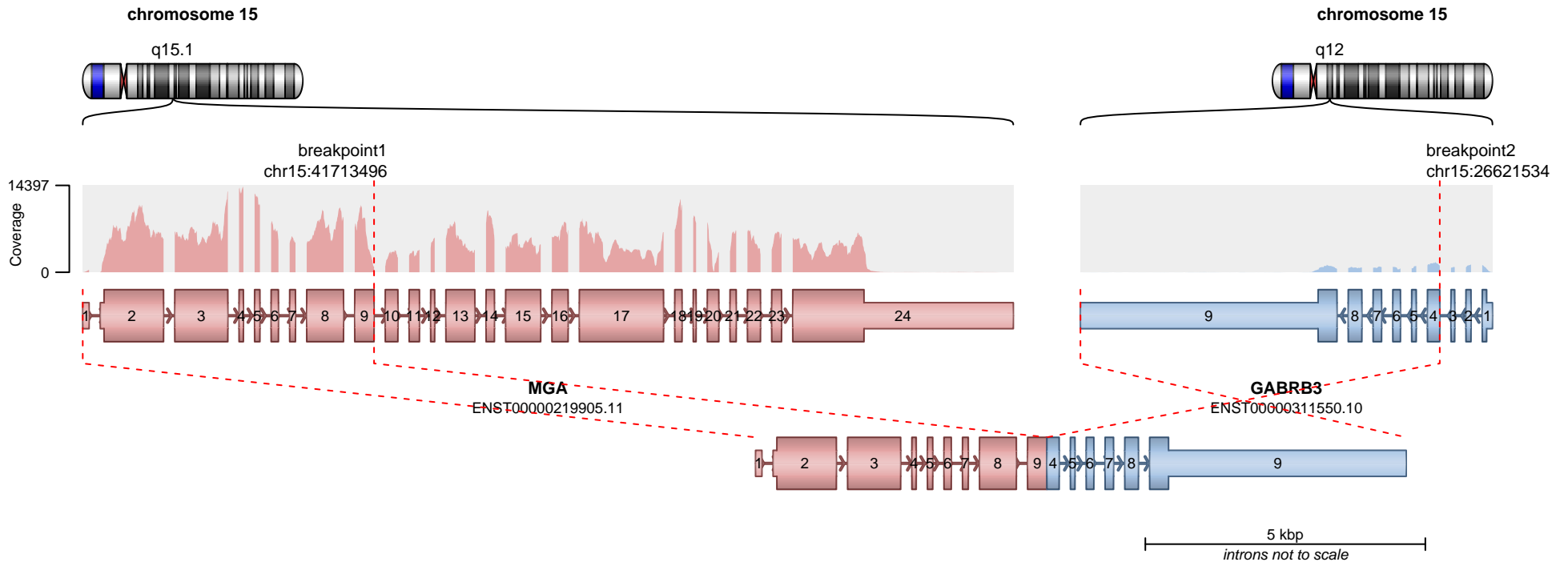

**RETAINED PROTEIN DOMAINS**  
reading frame unclear

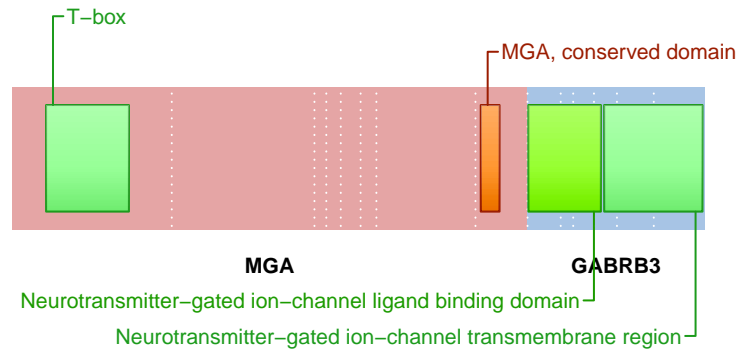

**SUPPORTING READ COUNT**

Split reads = 61  
Discordant mates = 2

— translocation    — deletion  
— duplication    — inversion

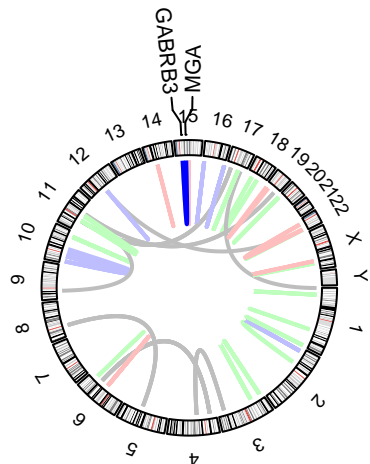
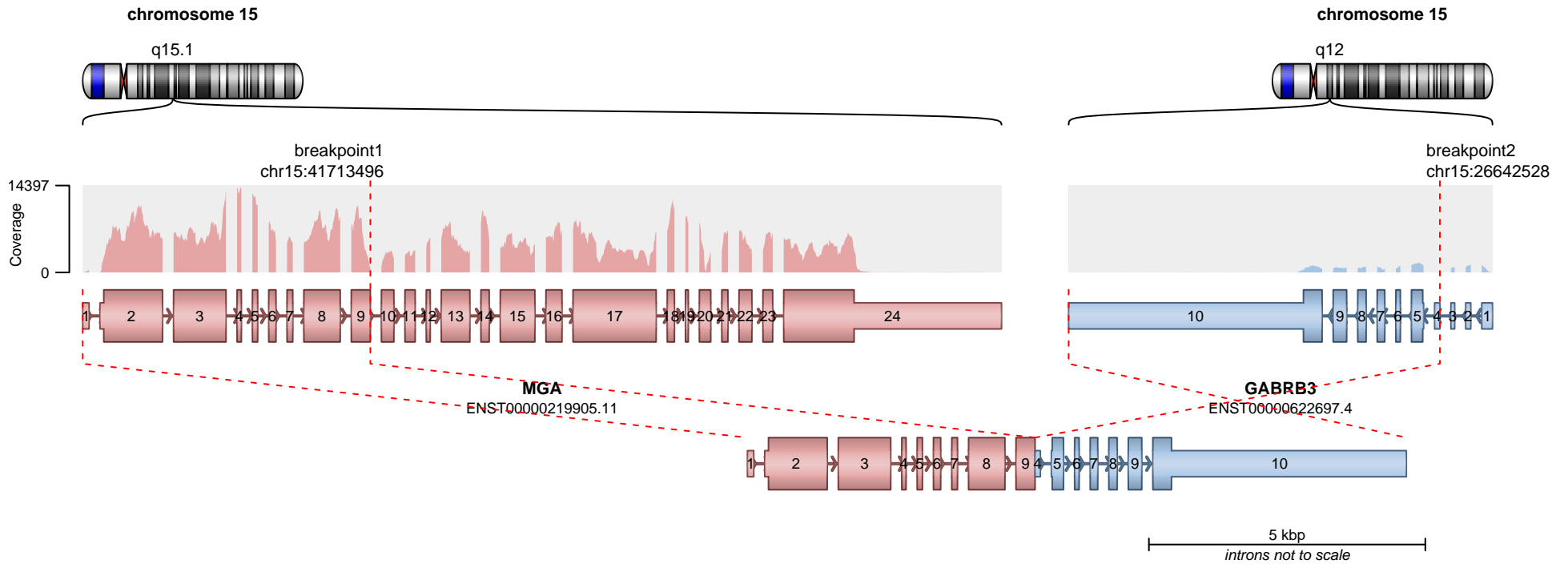

**RETAINED PROTEIN DOMAINS**  
reading frame unclear

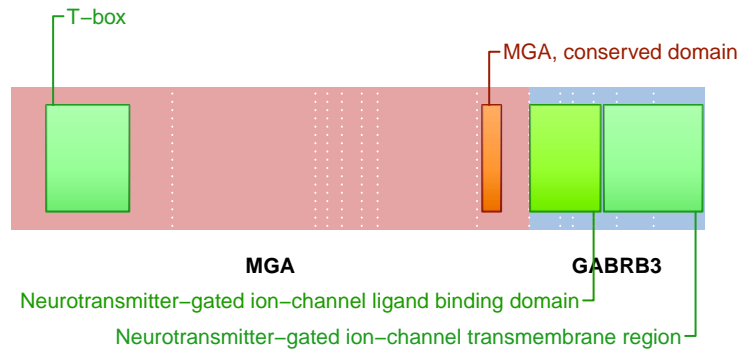

**SUPPORTING READ COUNT**

Split reads = 4  
Discordant mates = 2

- translocation
- duplication
- deletion
- inversion

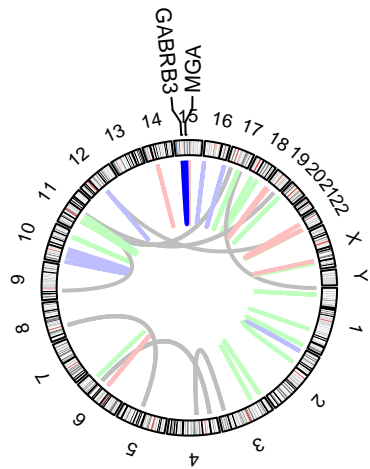
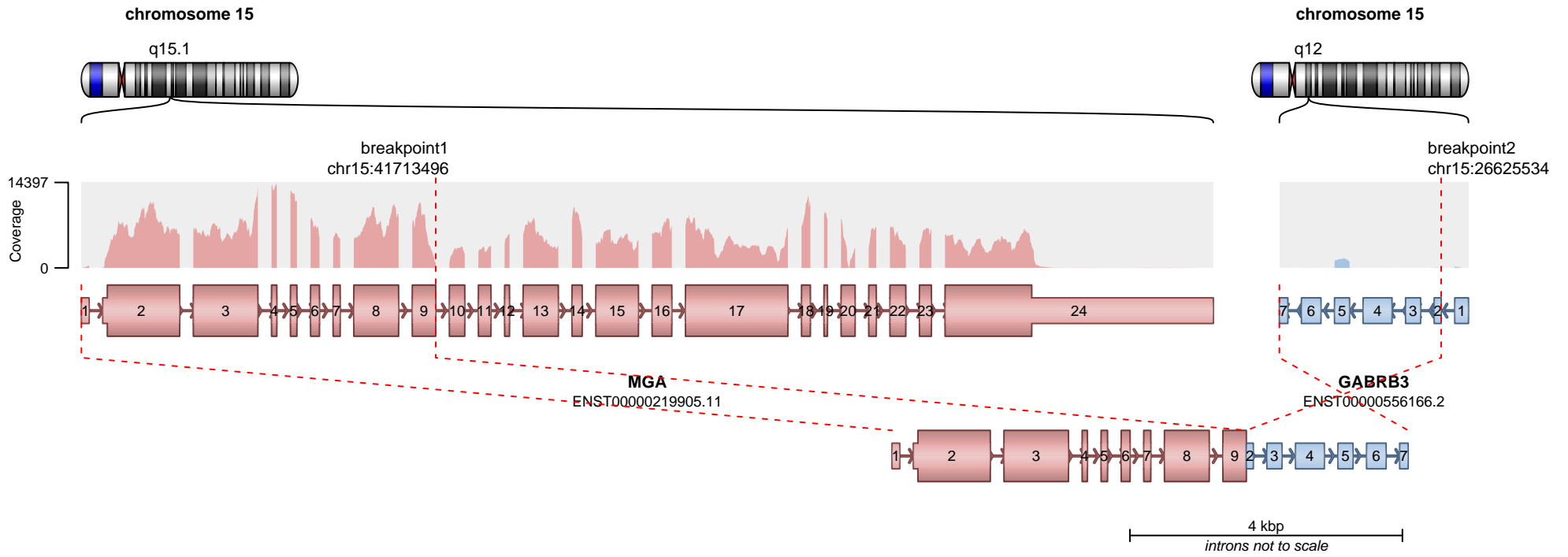

**RETAINED PROTEIN DOMAINS**  
reading frame unclear

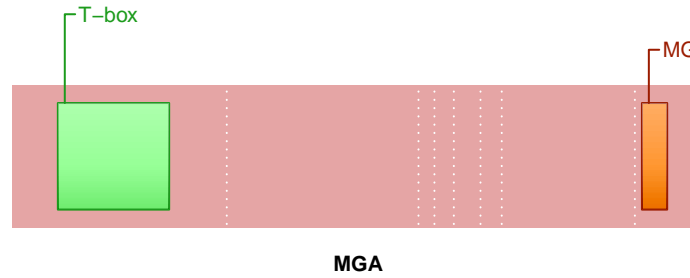

**SUPPORTING READ COUNT**

Split reads = 2  
Discordant mates = 2

- translocation
- duplication
- deletion
- inversion

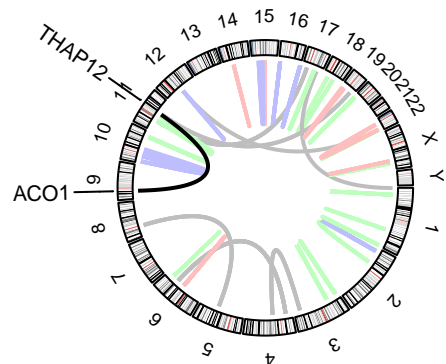
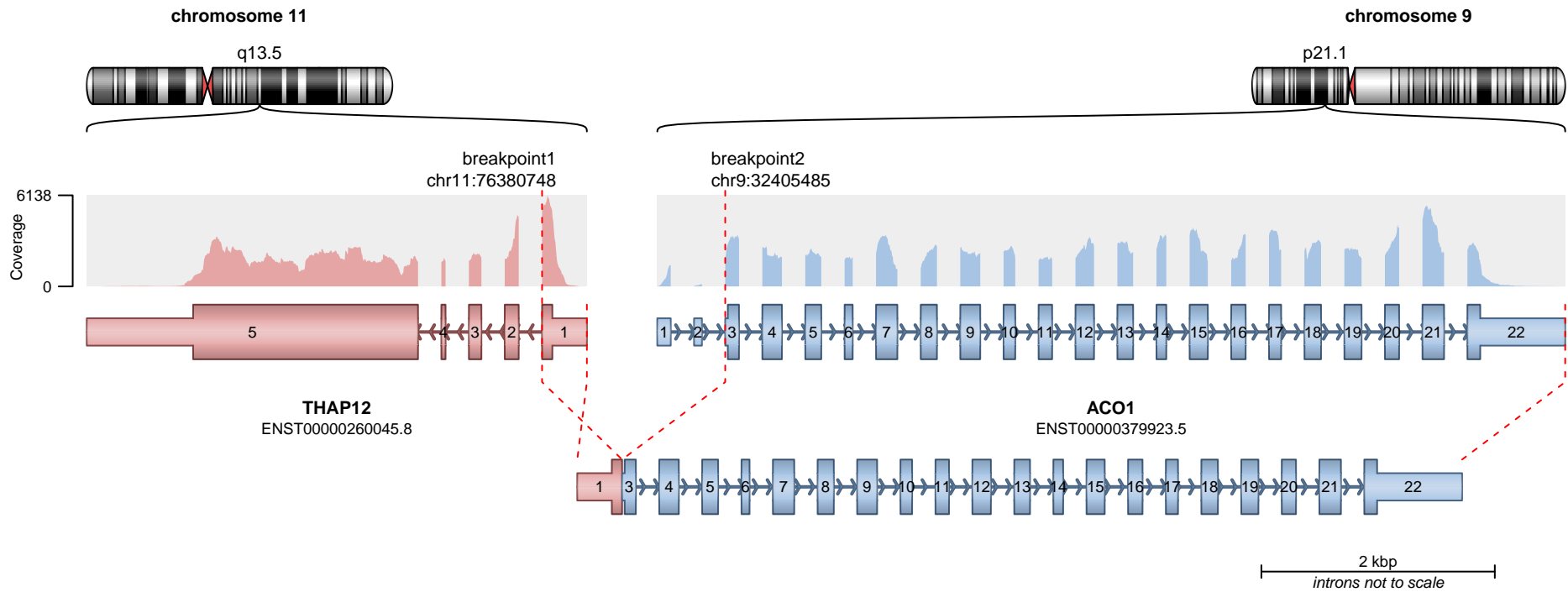

**RETAINED PROTEIN DOMAINS**  
reading frame unclear

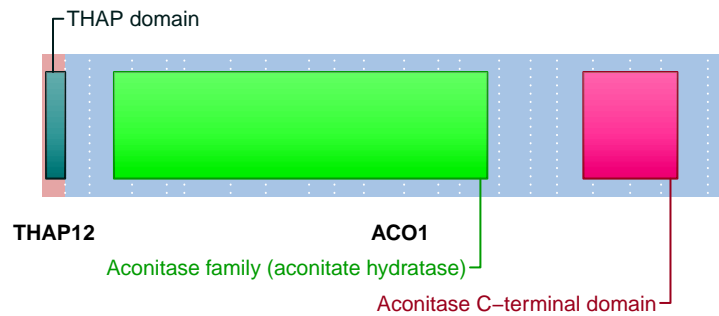

**SUPPORTING READ COUNT**

Split reads = 59  
Discordant mates = 0

- translocation
- duplication
- deletion
- inversion

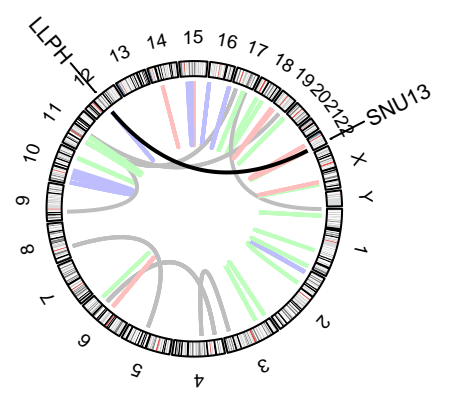
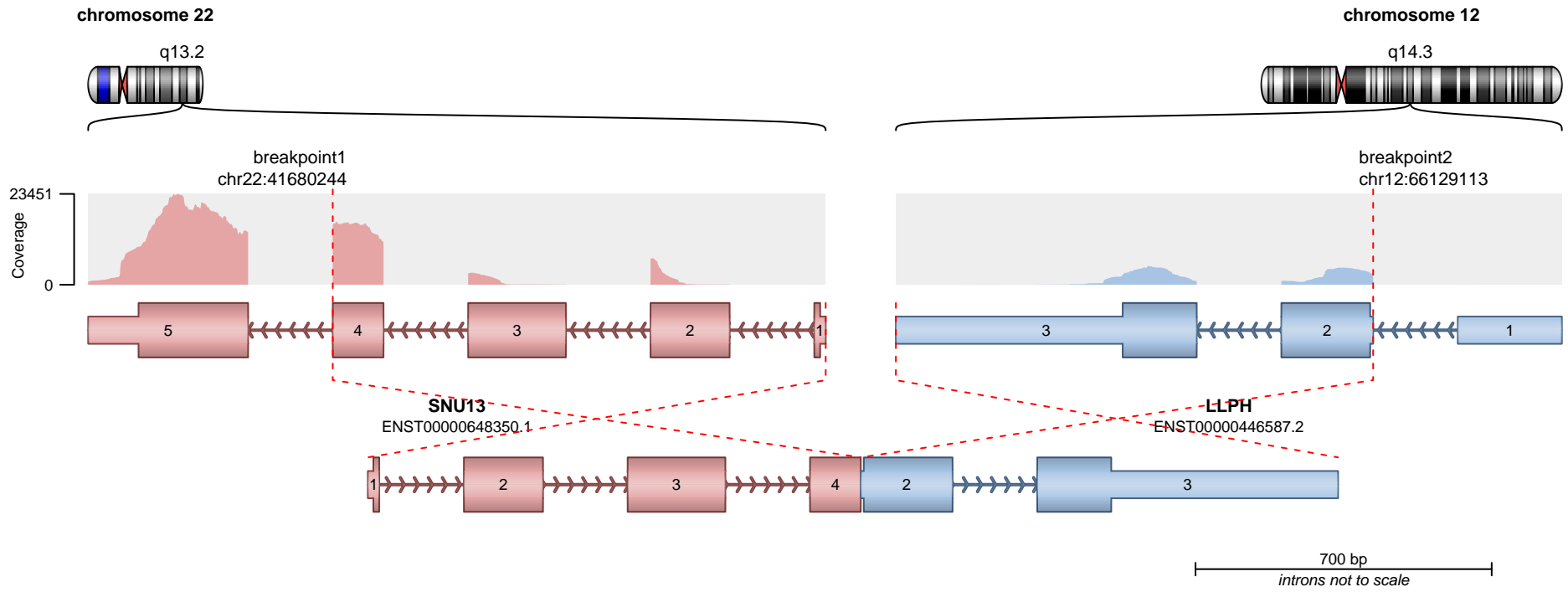

**RETAINED PROTEIN DOMAINS**  
reading frame unclear

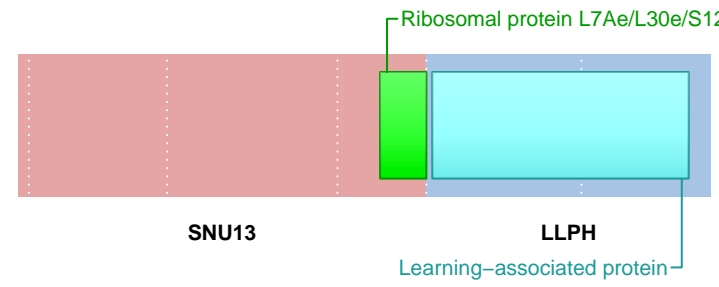

**SUPPORTING READ COUNT**

Split reads = 52  
Discordant mates = 1

- translocation
- duplication
- deletion
- inversion

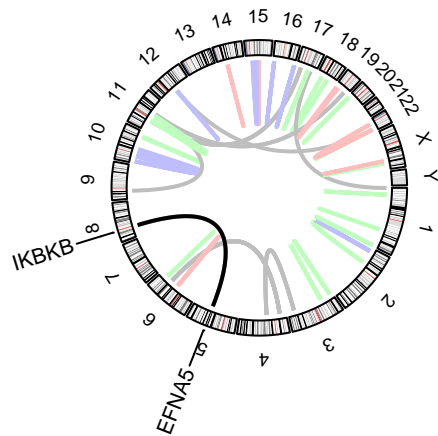
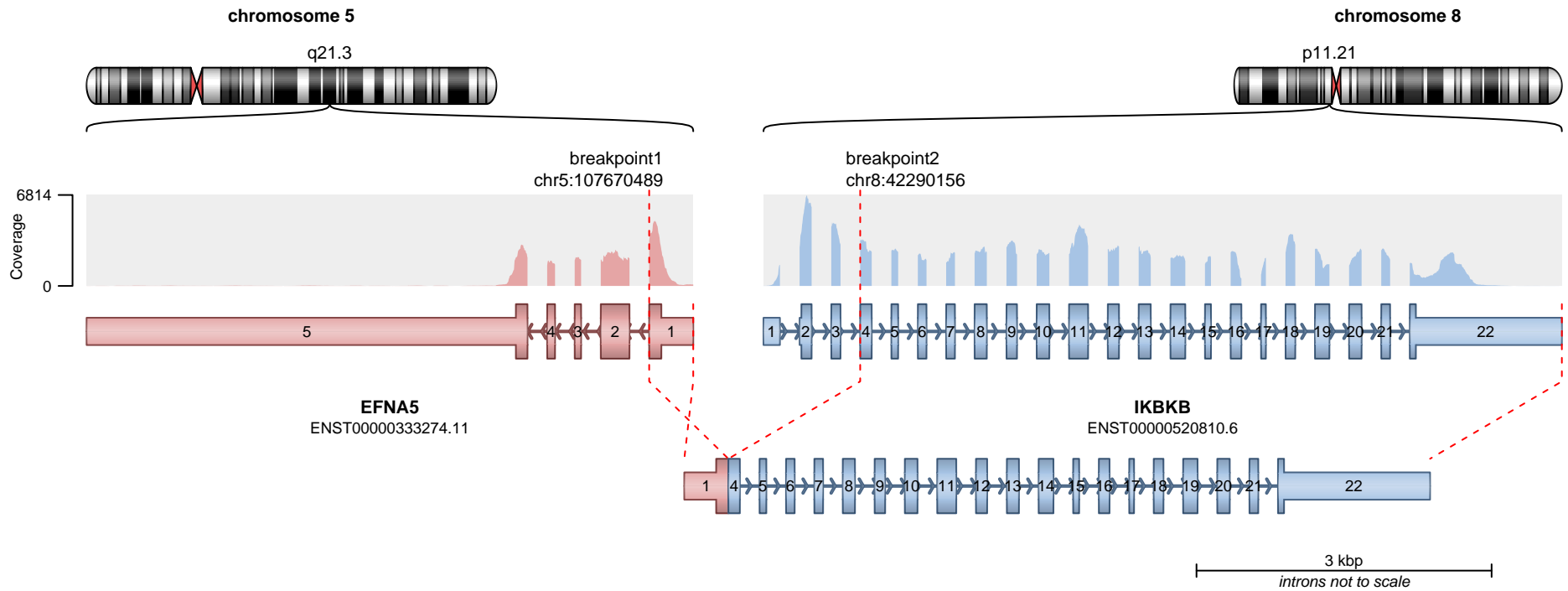

— translocation    — deletion  
— duplication    — inversion

**RETAINED PROTEIN DOMAINS**  
reading frame unclear

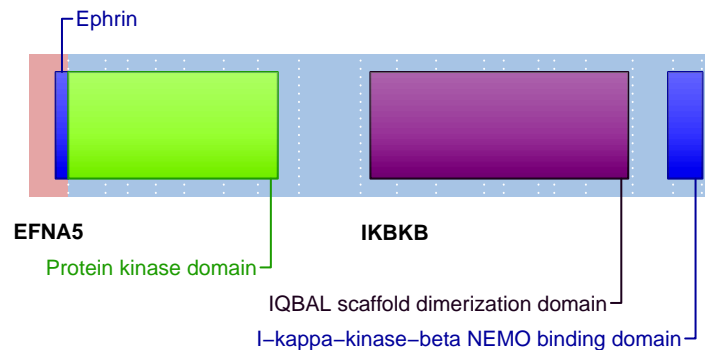

**SUPPORTING READ COUNT**

Split reads = 42  
Discordant mates = 0

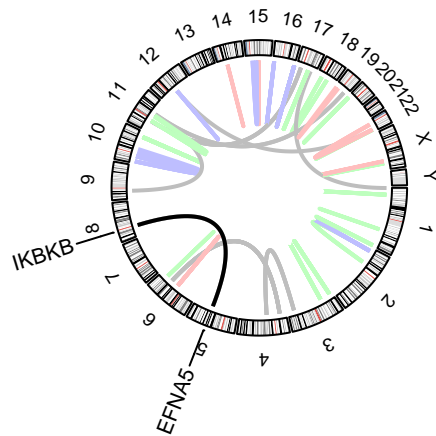
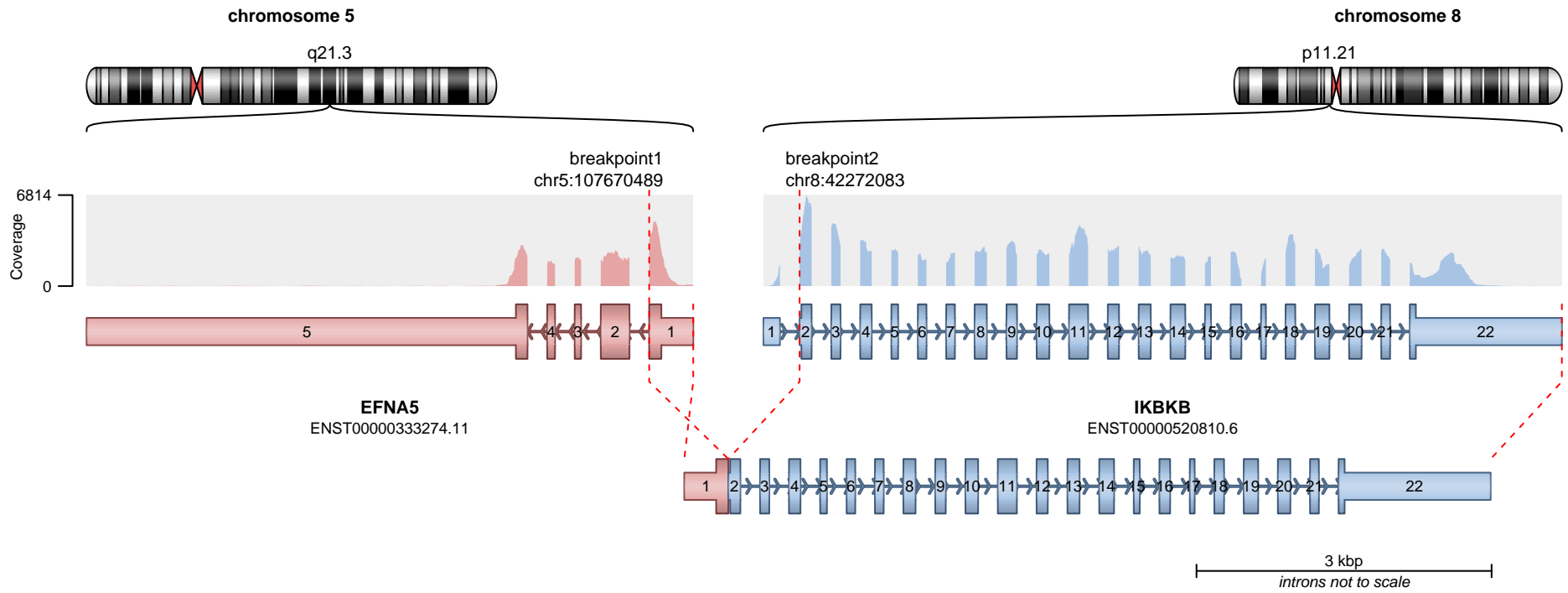

— translocation — deletion  
— duplication — inversion

**RETAINED PROTEIN DOMAINS**  
reading frame unclear

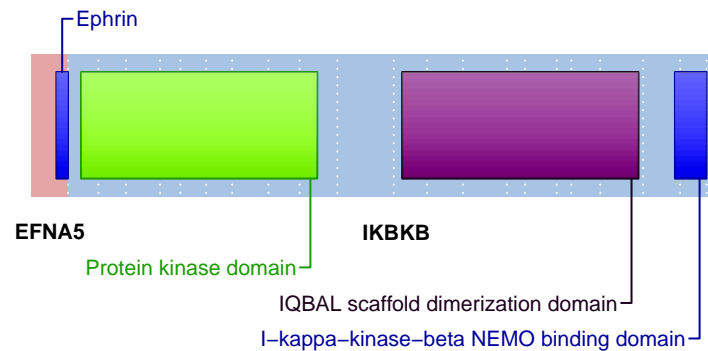

**SUPPORTING READ COUNT**

Split reads = 2  
Discordant mates = 2

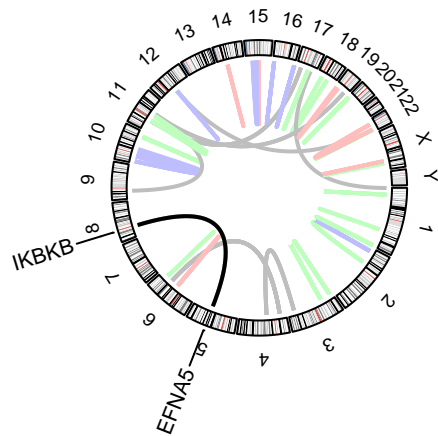
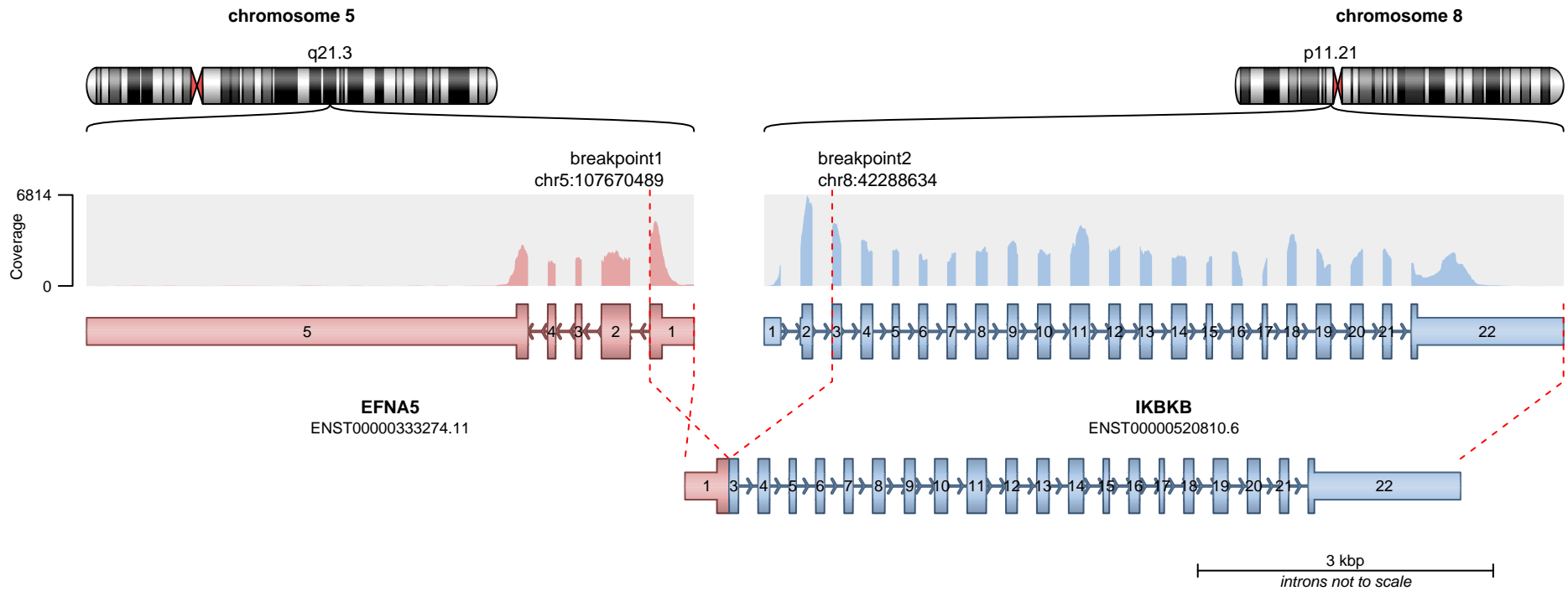

**RETAINED PROTEIN DOMAINS**  
reading frame unclear

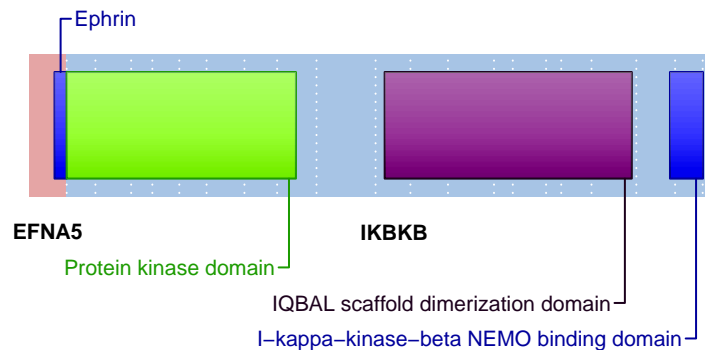

**SUPPORTING READ COUNT**

Split reads = 1  
Discordant mates = 2

— translocation    — deletion  
— duplication    — inversion

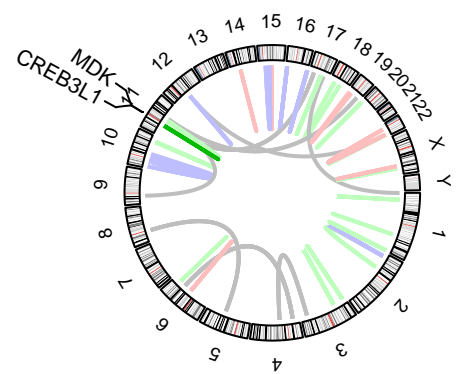
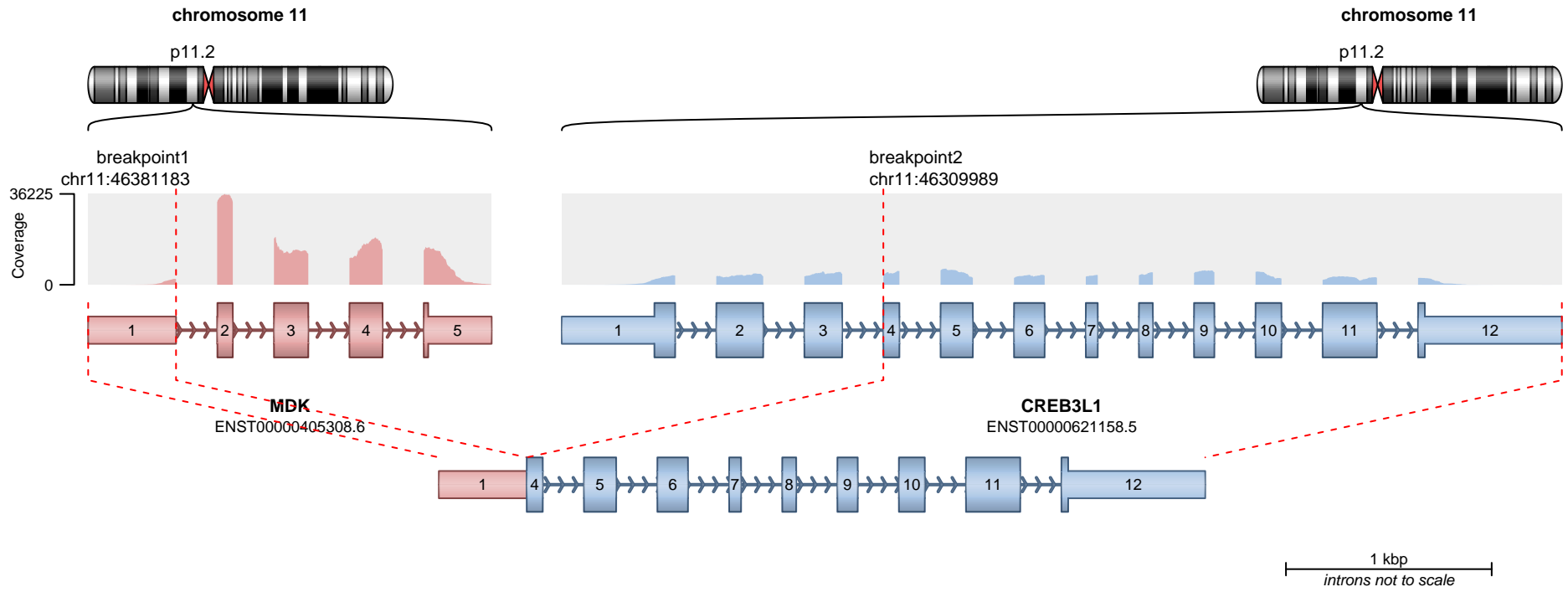

**RETAINED PROTEIN DOMAINS**  
reading frame unclear

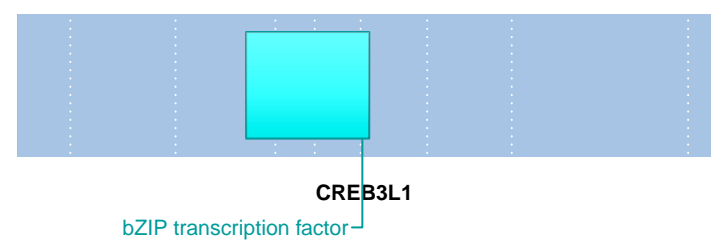

**SUPPORTING READ COUNT**

Split reads = 29  
Discordant mates = 0

— translocation    — deletion  
— duplication    — inversion

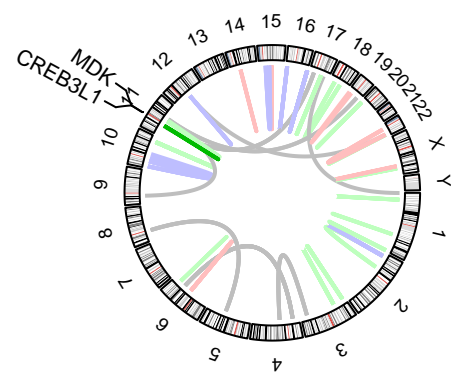
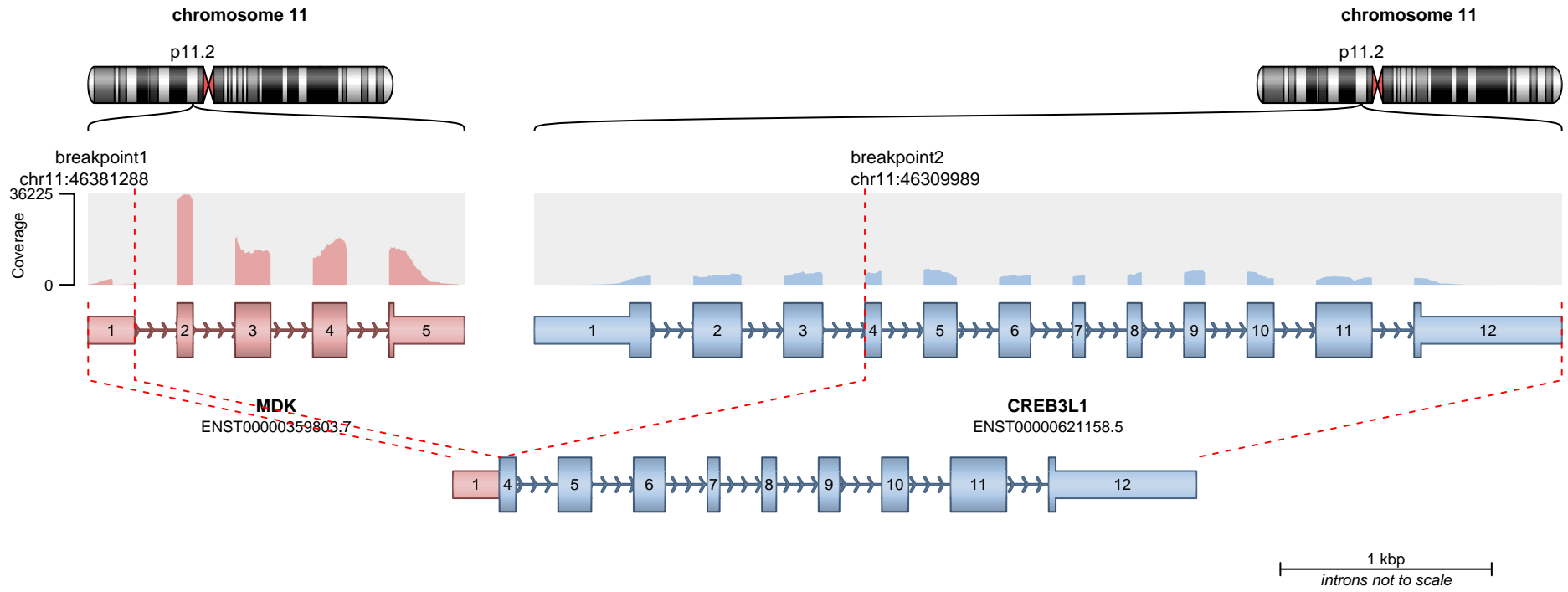

— translocation — deletion  
— duplication — inversion

**RETAINED PROTEIN DOMAINS**  
reading frame unclear

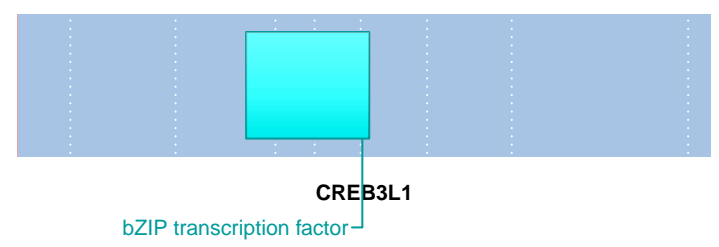

**SUPPORTING READ COUNT**

Split reads = 1  
Discordant mates = 0

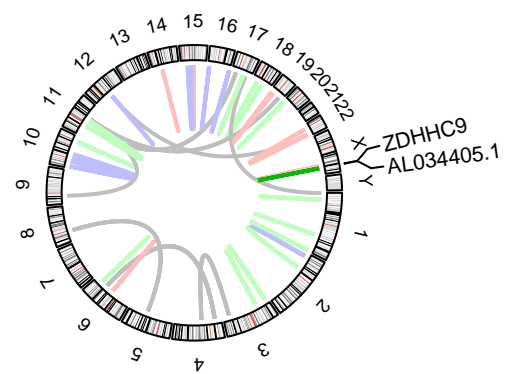
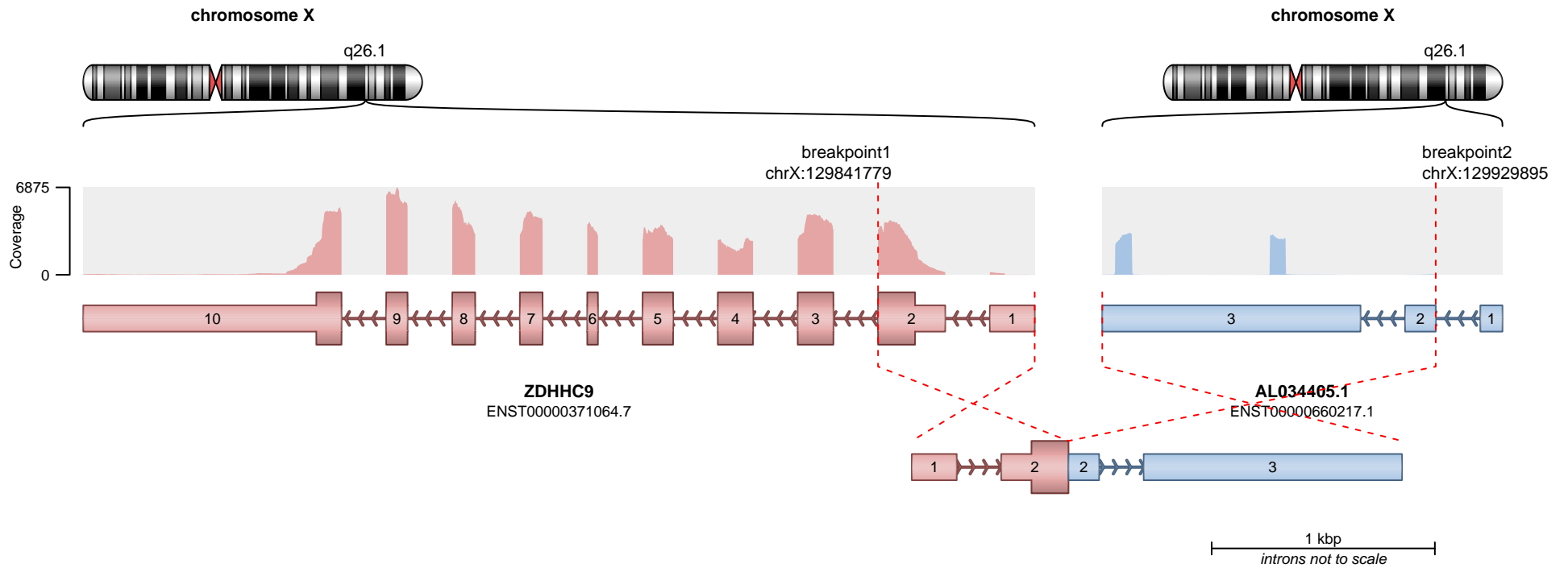

— translocation    — deletion  
 — duplication    — inversion

No protein domains retained in fusion.

**SUPPORTING READ COUNT**

Split reads = 26  
 Discordant mates = 1

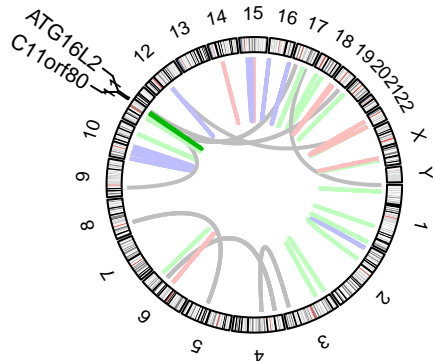
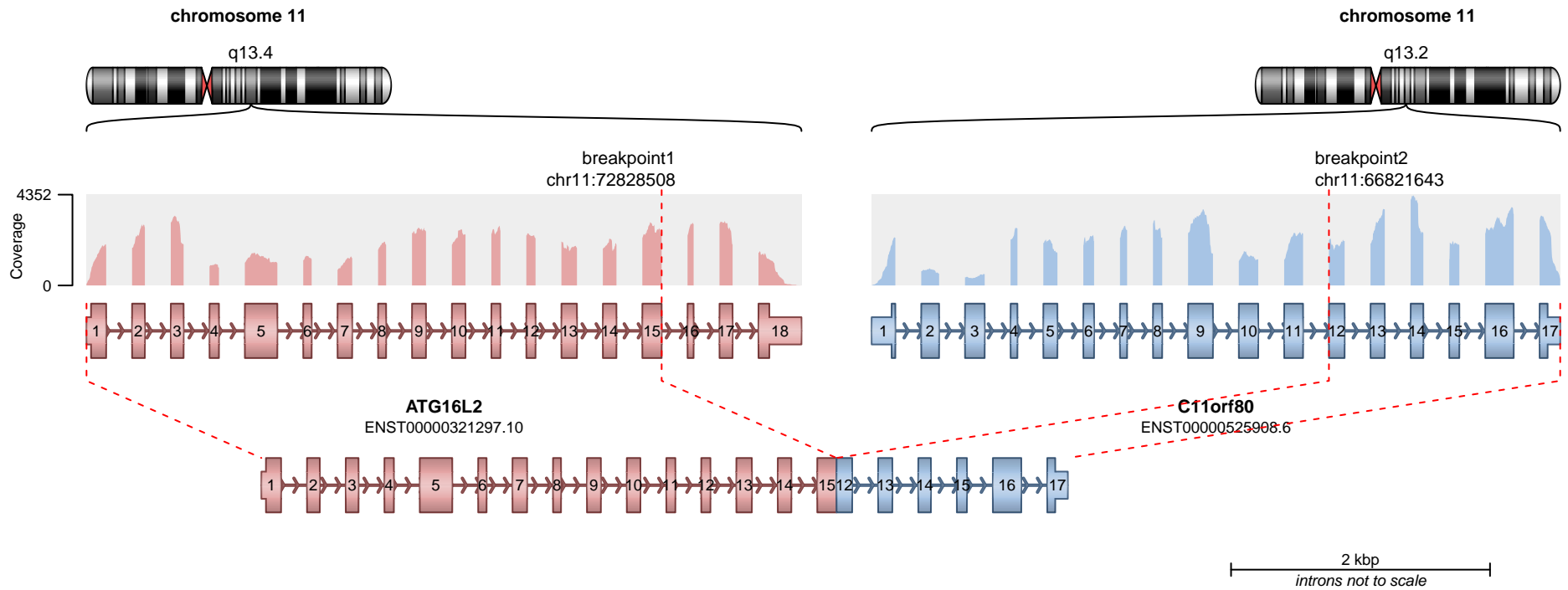

**RETAINED PROTEIN DOMAINS**  
reading frame unclear

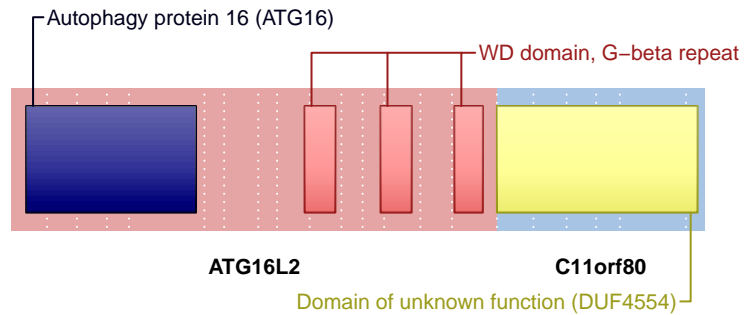

**SUPPORTING READ COUNT**

Split reads = 26  
Discordant mates = 0

- translocation
- duplication
- deletion
- inversion

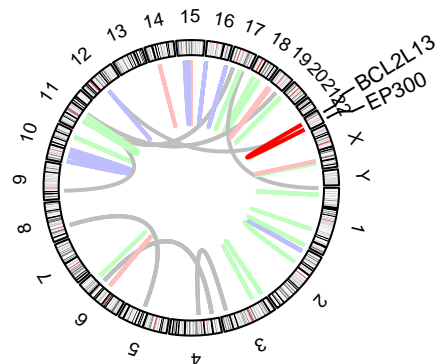
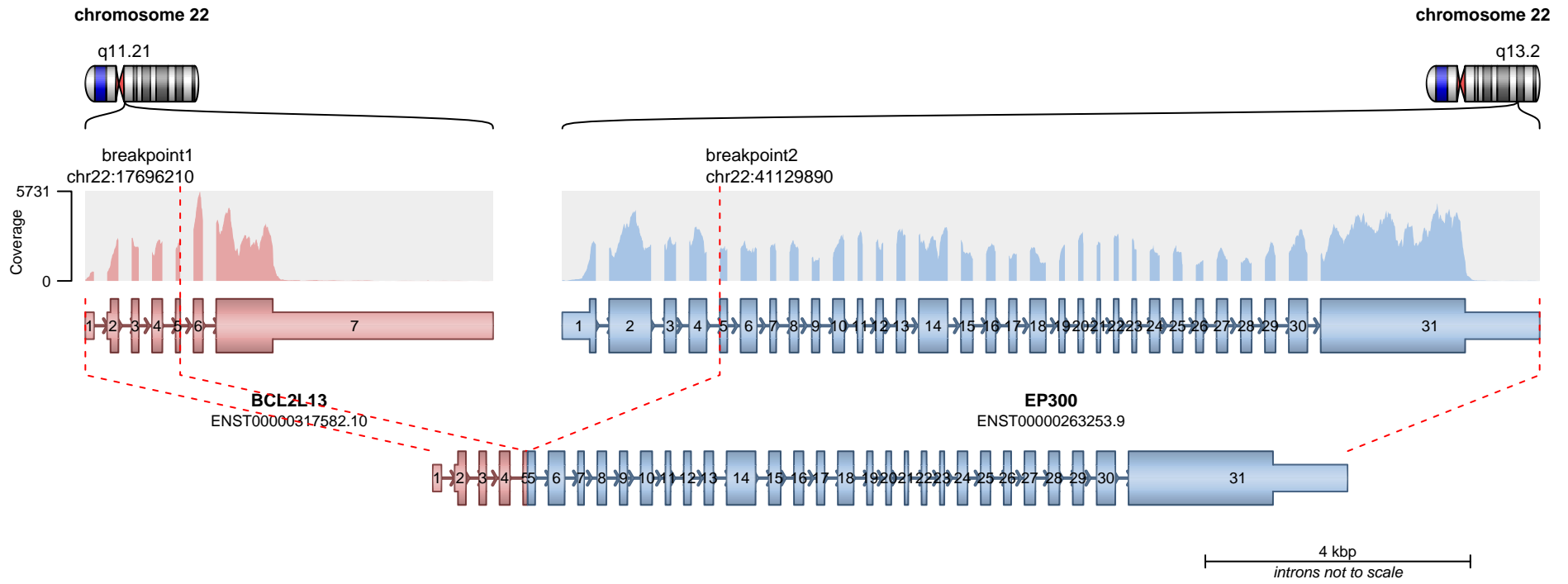

— translocation    — deletion  
— duplication    — inversion

**RETAINED PROTEIN DOMAINS**  
reading frame unclear

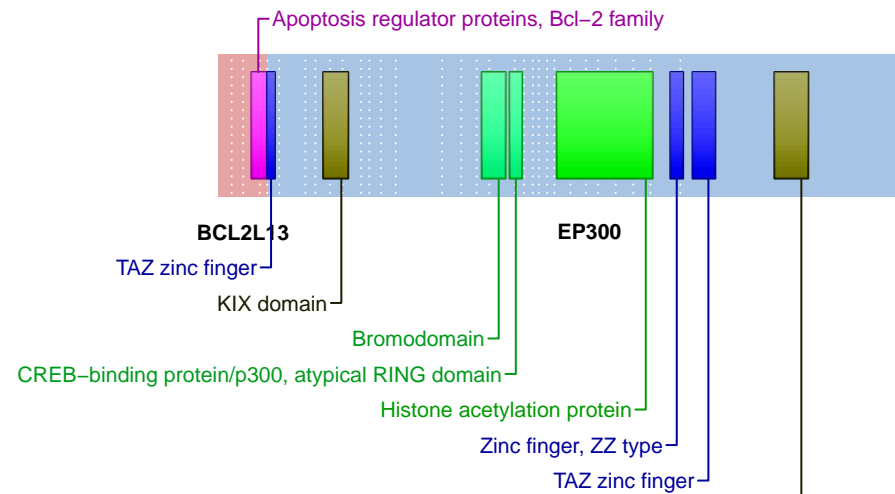

**SUPPORTING READ COUNT**

Split reads = 25  
Discordant mates = 4

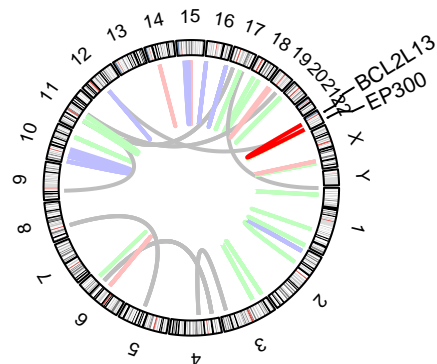
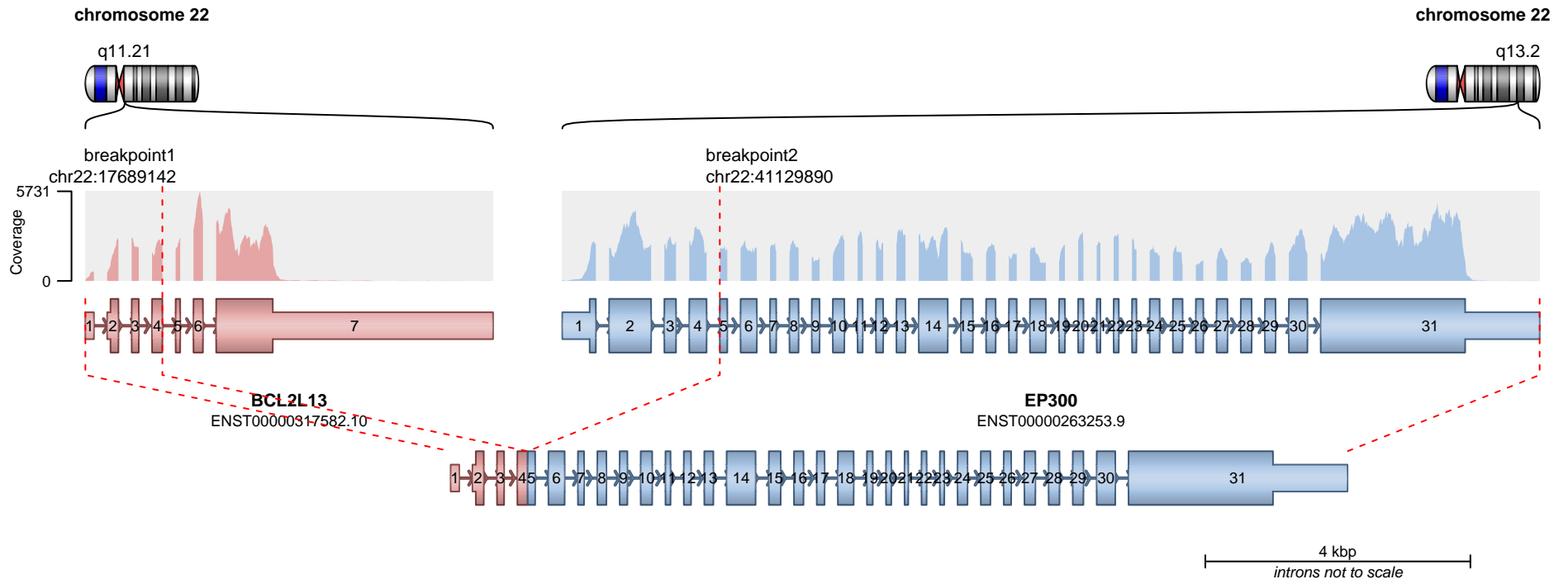

— translocation — deletion  
— duplication — inversion

**RETAINED PROTEIN DOMAINS**  
reading frame unclear

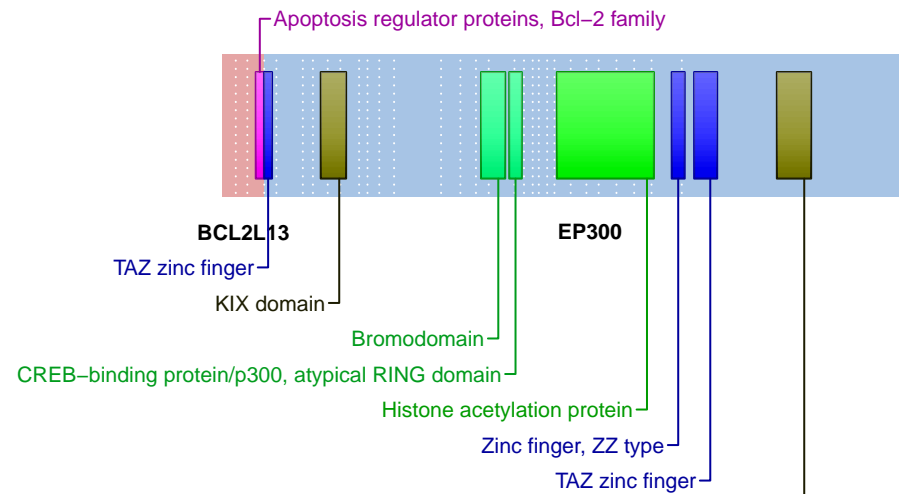

**SUPPORTING READ COUNT**

Split reads = 7  
Discordant mates = 1

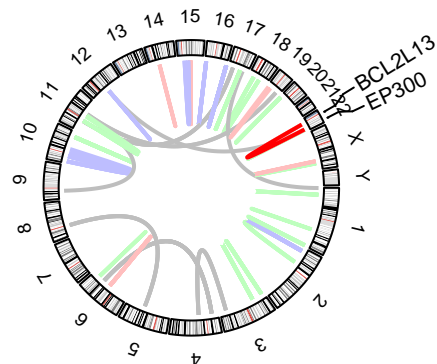
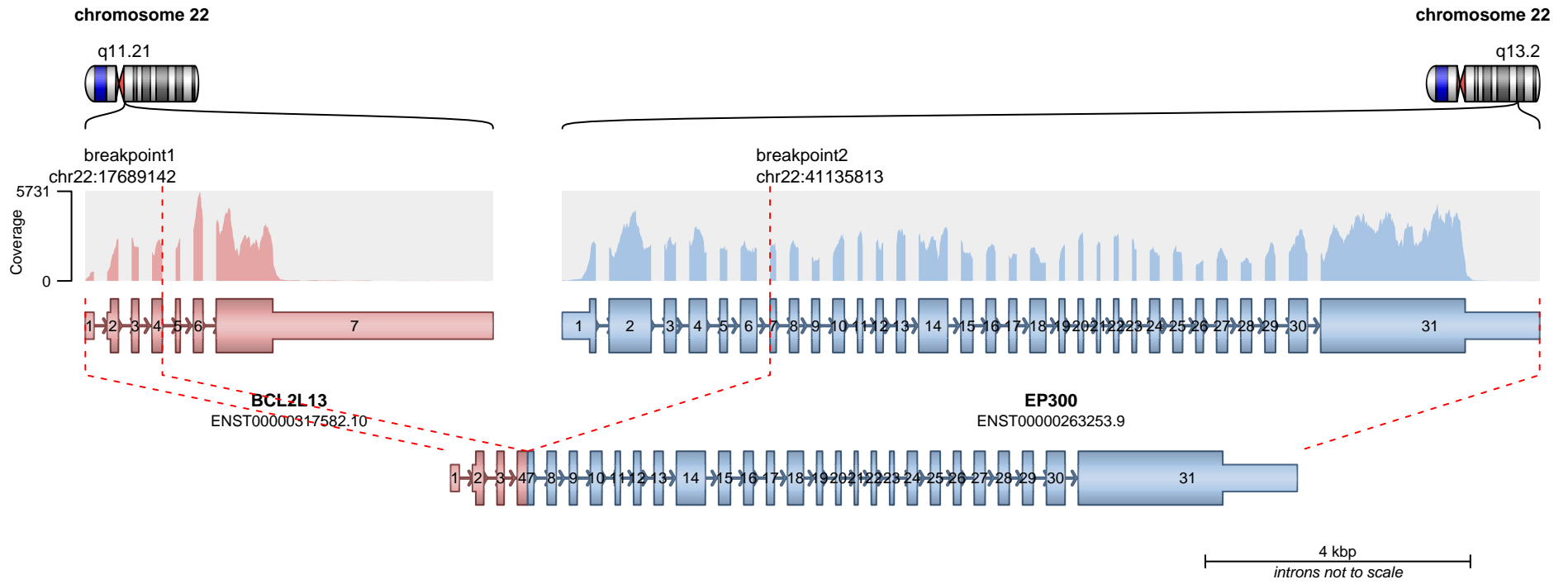

— translocation — deletion  
— duplication — inversion

**RETAINED PROTEIN DOMAINS**  
reading frame unclear

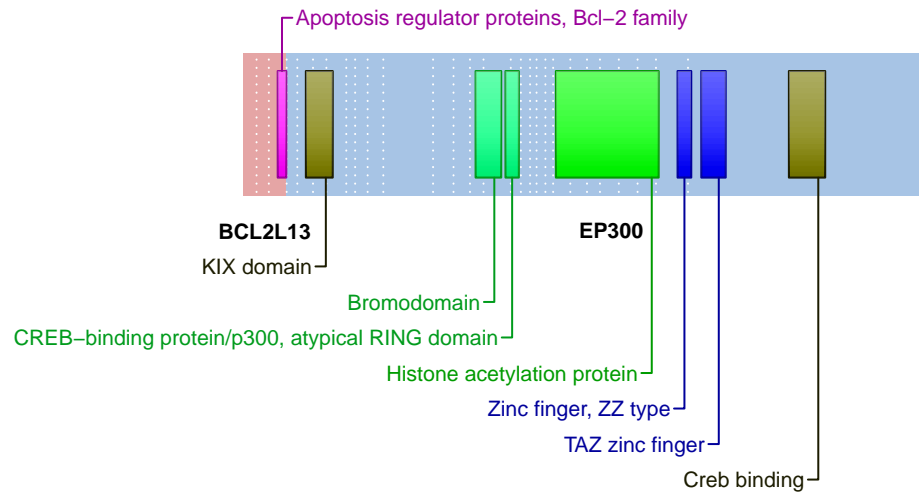

**SUPPORTING READ COUNT**

Split reads = 1  
Discordant mates = 0

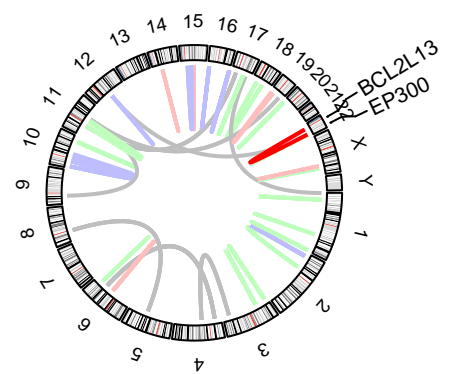
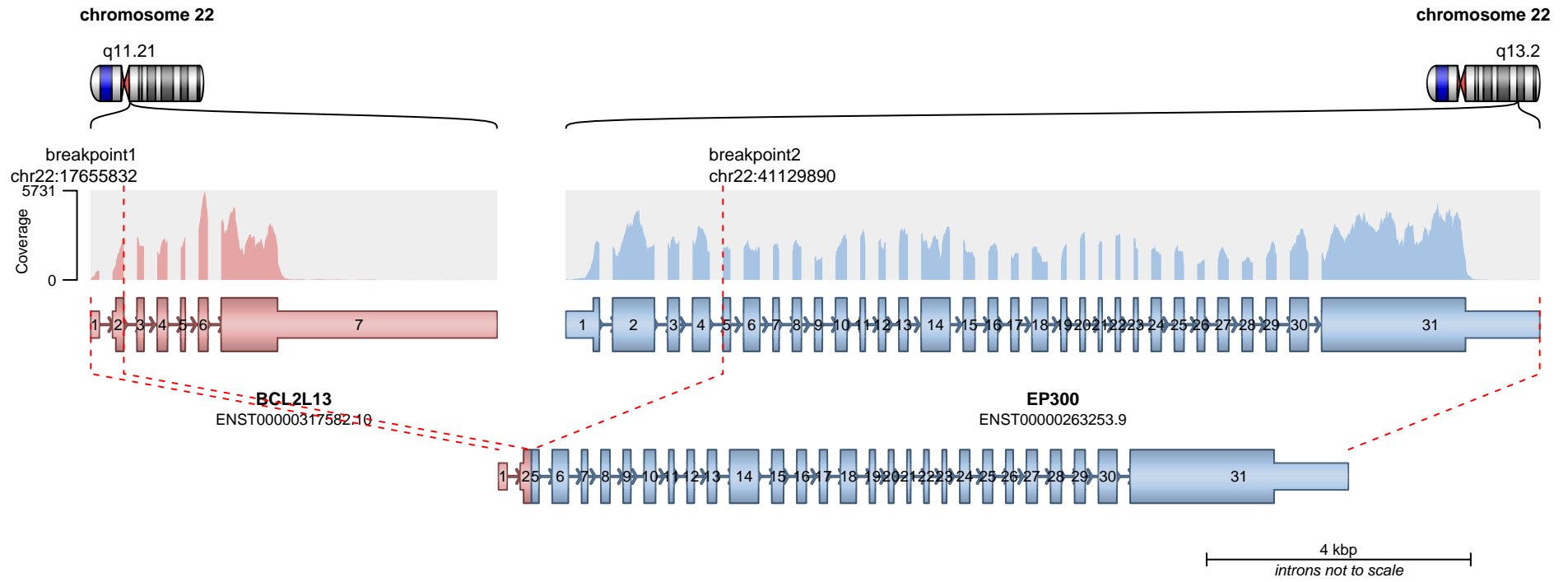

— translocation    — deletion  
— duplication    — inversion

**RETAINED PROTEIN DOMAINS**  
reading frame unclear

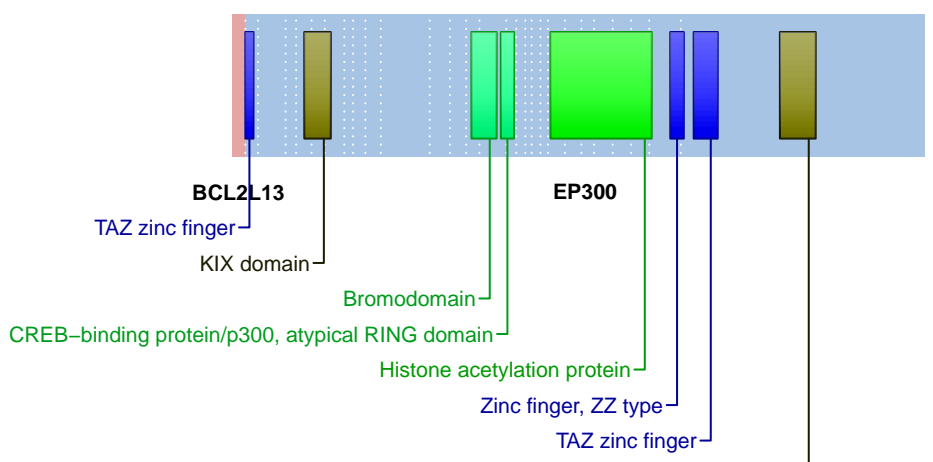

**SUPPORTING READ COUNT**

Split reads = 1  
Discordant mates = 0

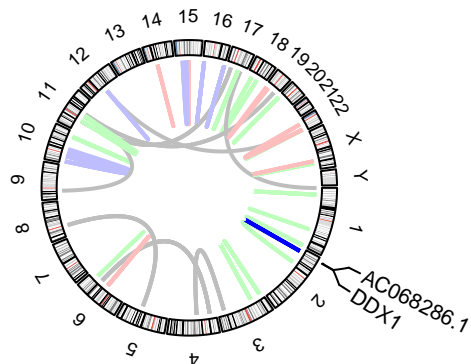
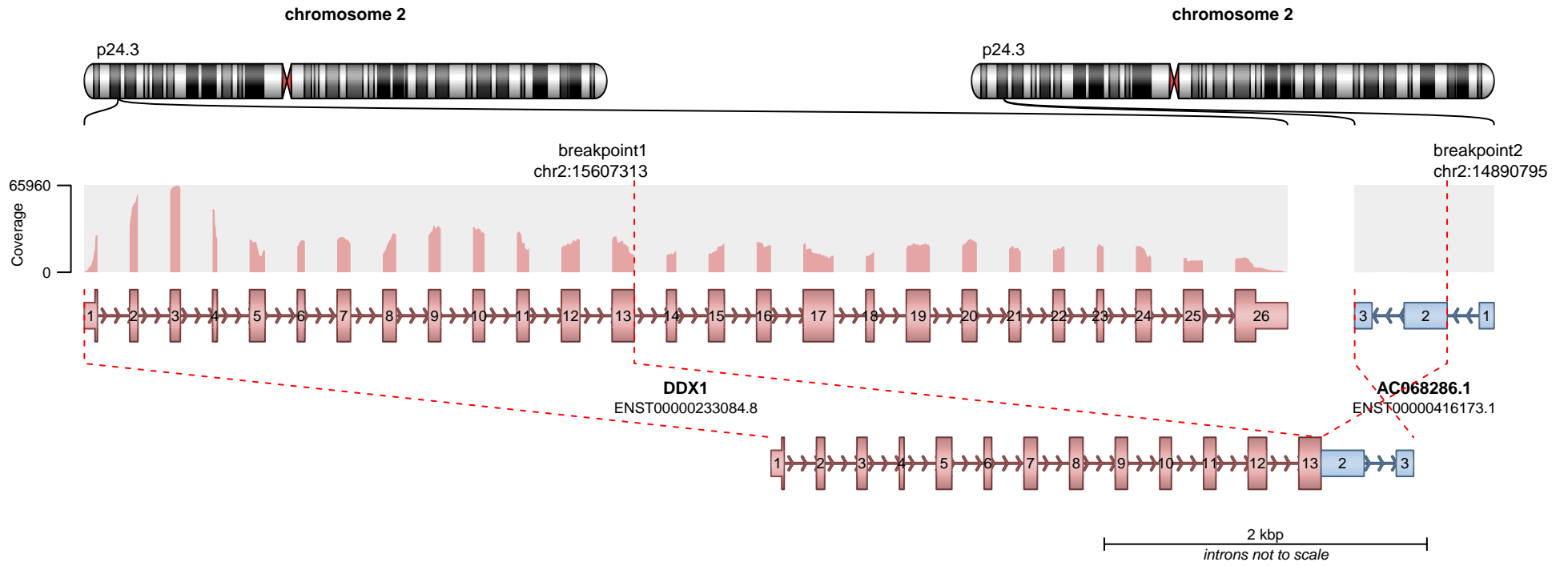

**RETAINED PROTEIN DOMAINS**  
reading frame unclear

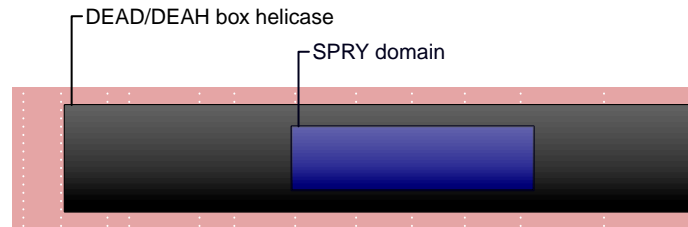

**SUPPORTING READ COUNT**

Split reads = 24  
Discordant mates = 2

- translocation
- duplication
- deletion
- inversion

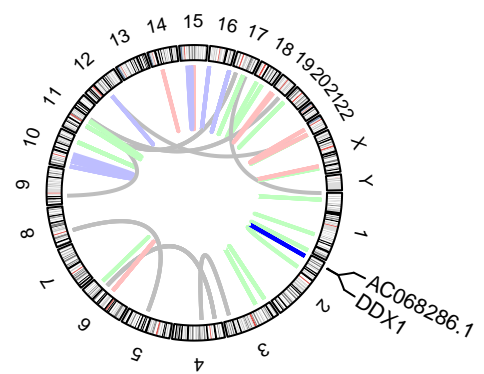
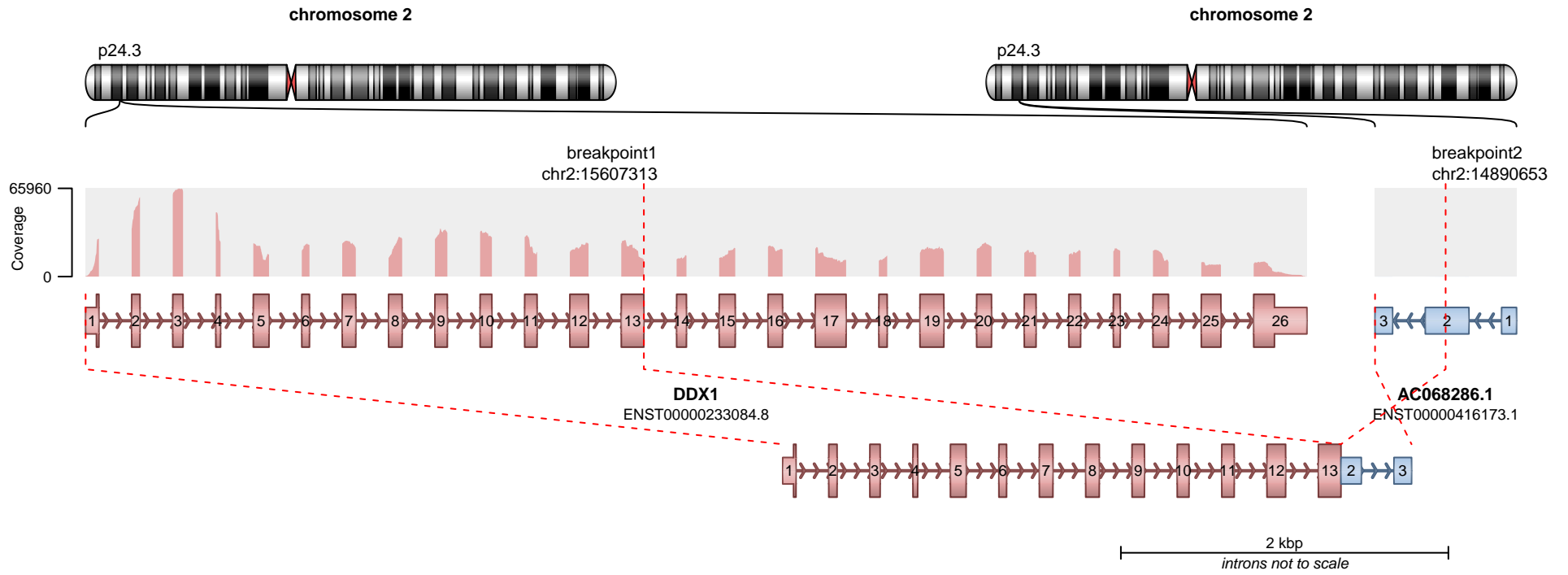

**RETAINED PROTEIN DOMAINS**  
reading frame unclear

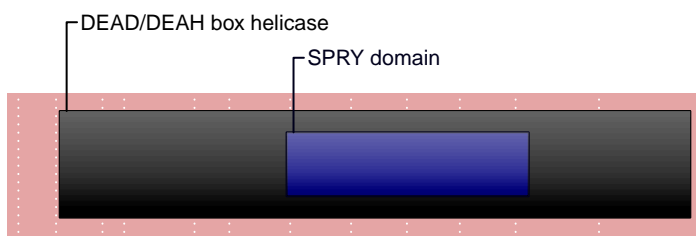

**DDX1**

**SUPPORTING READ COUNT**

Split reads = 17  
Discordant mates = 0

- translocation
- duplication
- deletion
- inversion

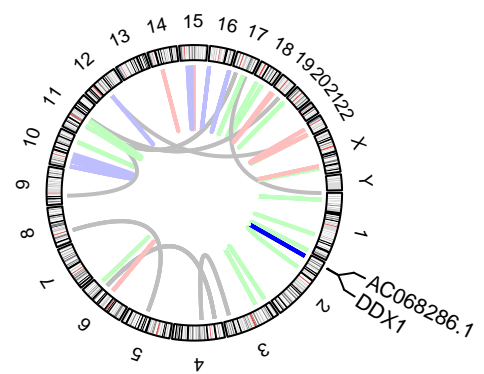
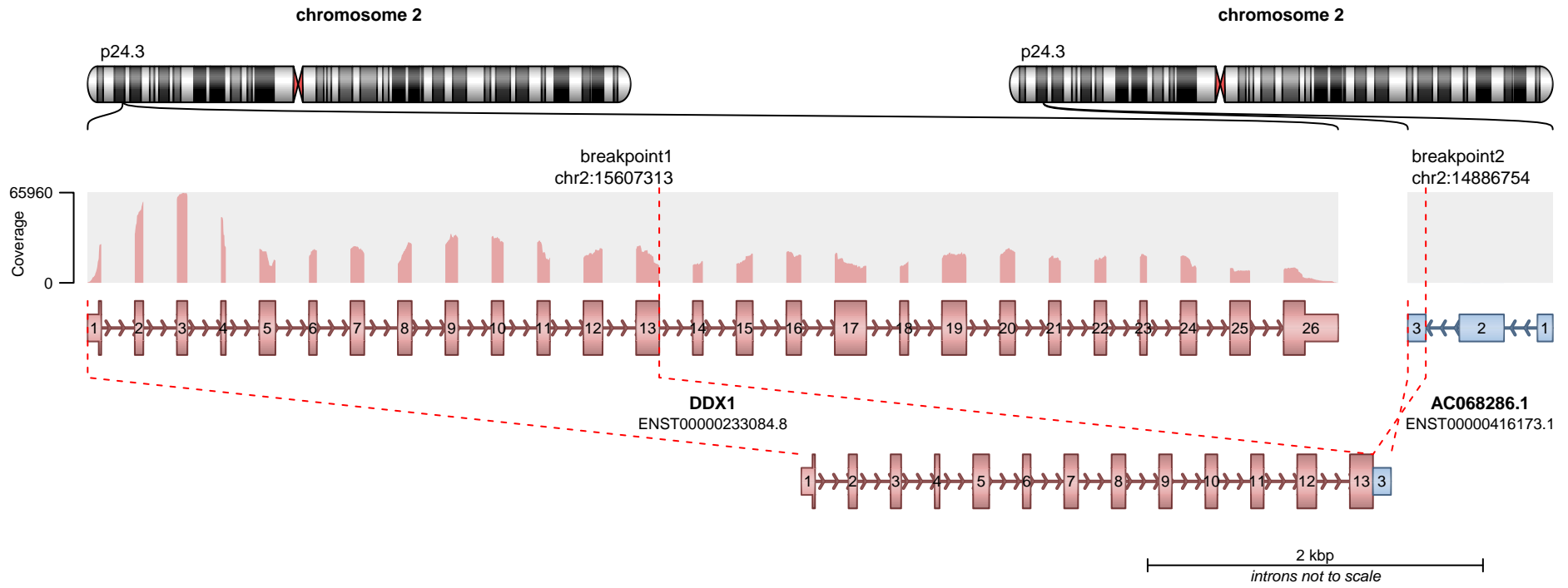

**RETAINED PROTEIN DOMAINS**  
reading frame unclear

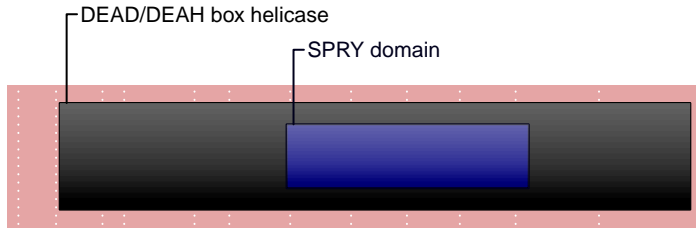

**SUPPORTING READ COUNT**

Split reads = 13  
Discordant mates = 0

- translocation
- duplication
- deletion
- inversion

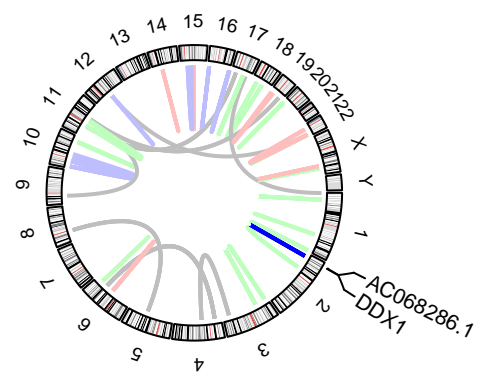
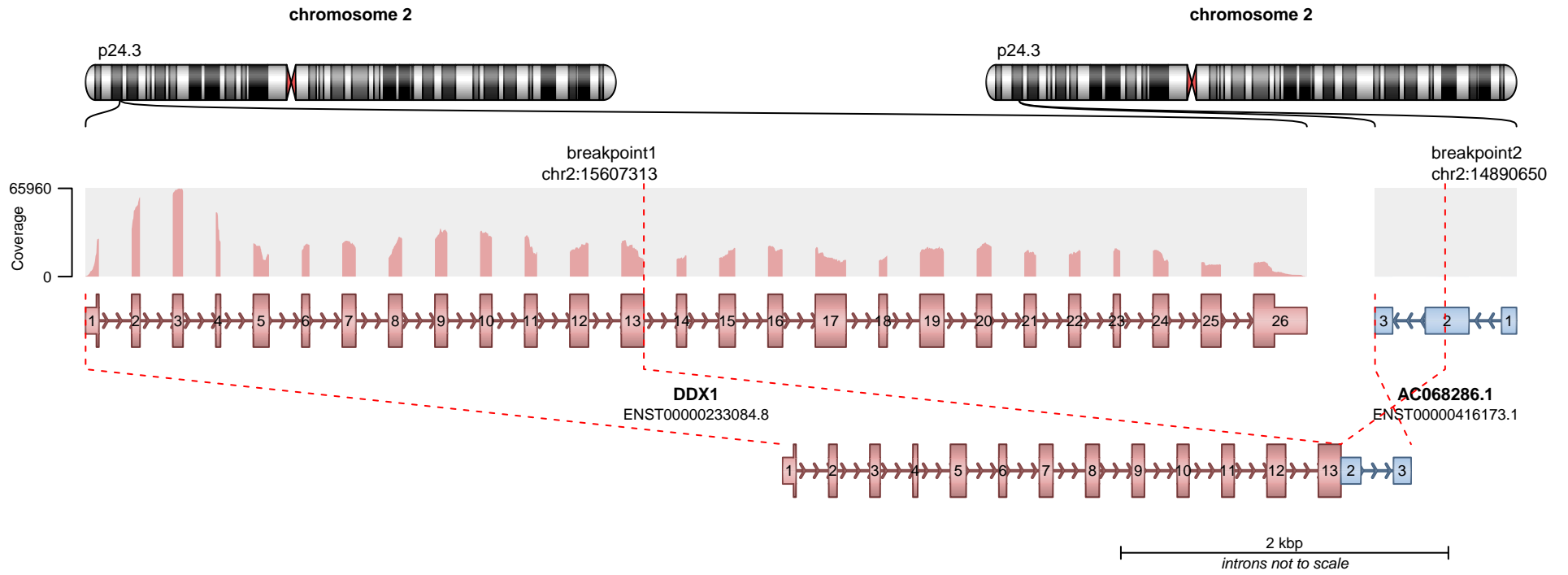

**RETAINED PROTEIN DOMAINS**  
reading frame unclear

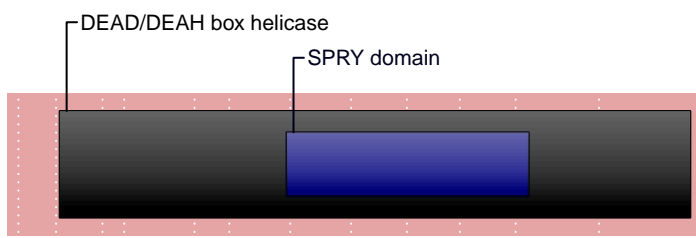

**SUPPORTING READ COUNT**

Split reads = 10  
Discordant mates = 0

- translocation
- duplication
- deletion
- inversion

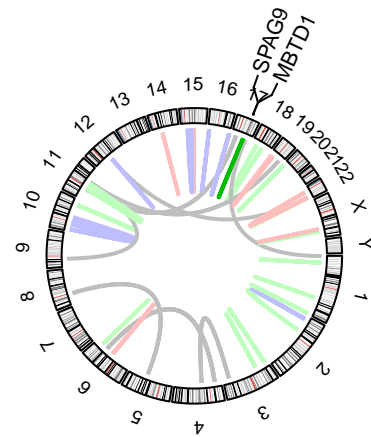
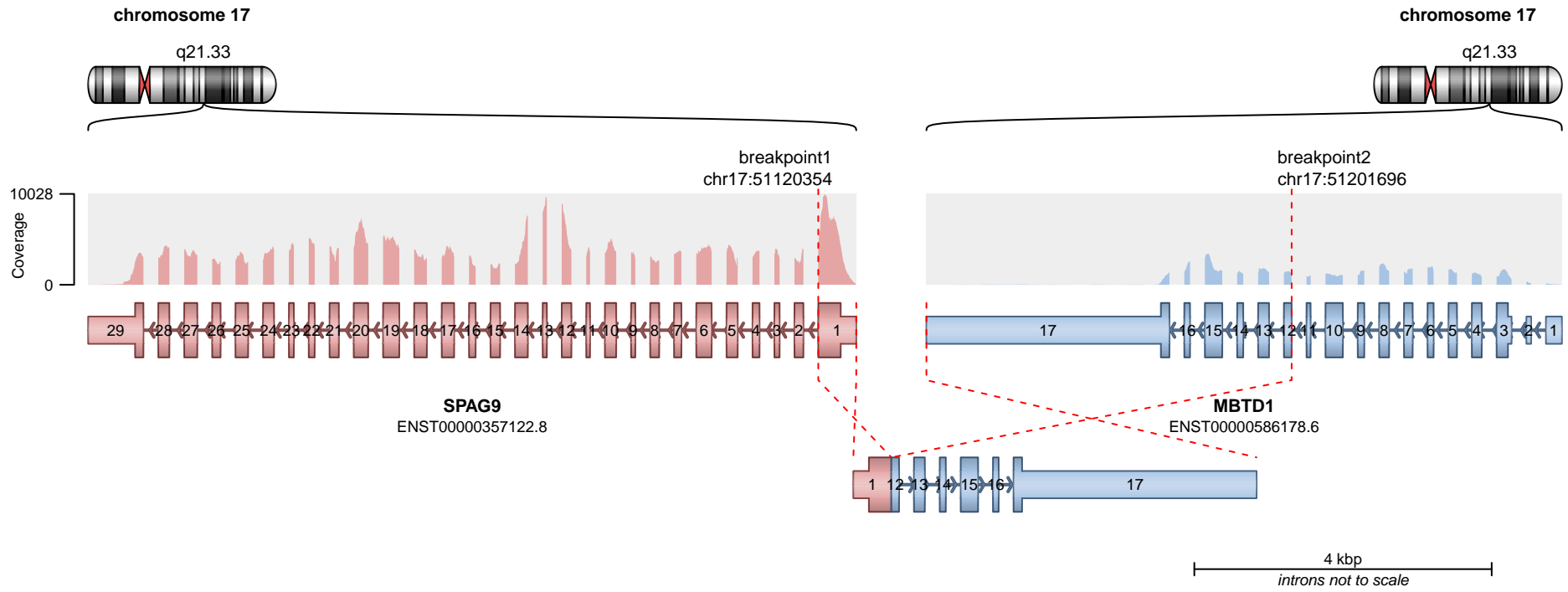

**RETAINED PROTEIN DOMAINS**  
reading frame unclear

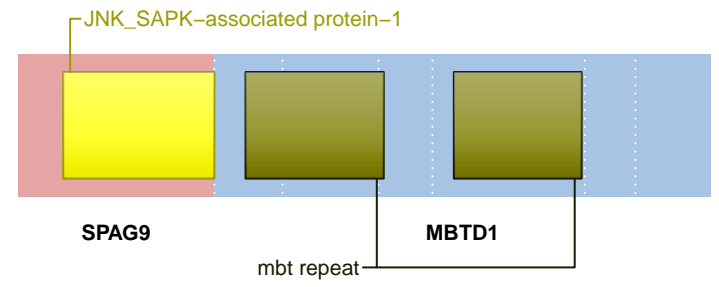

**SUPPORTING READ COUNT**

Split reads = 23  
Discordant mates = 2

- translocation
- duplication
- deletion
- inversion

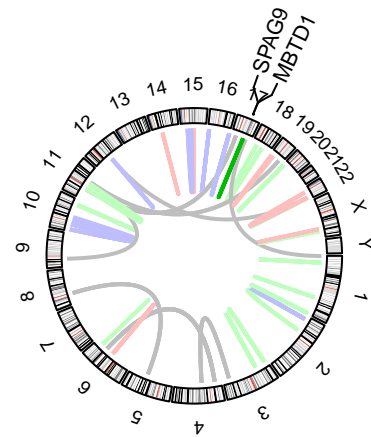
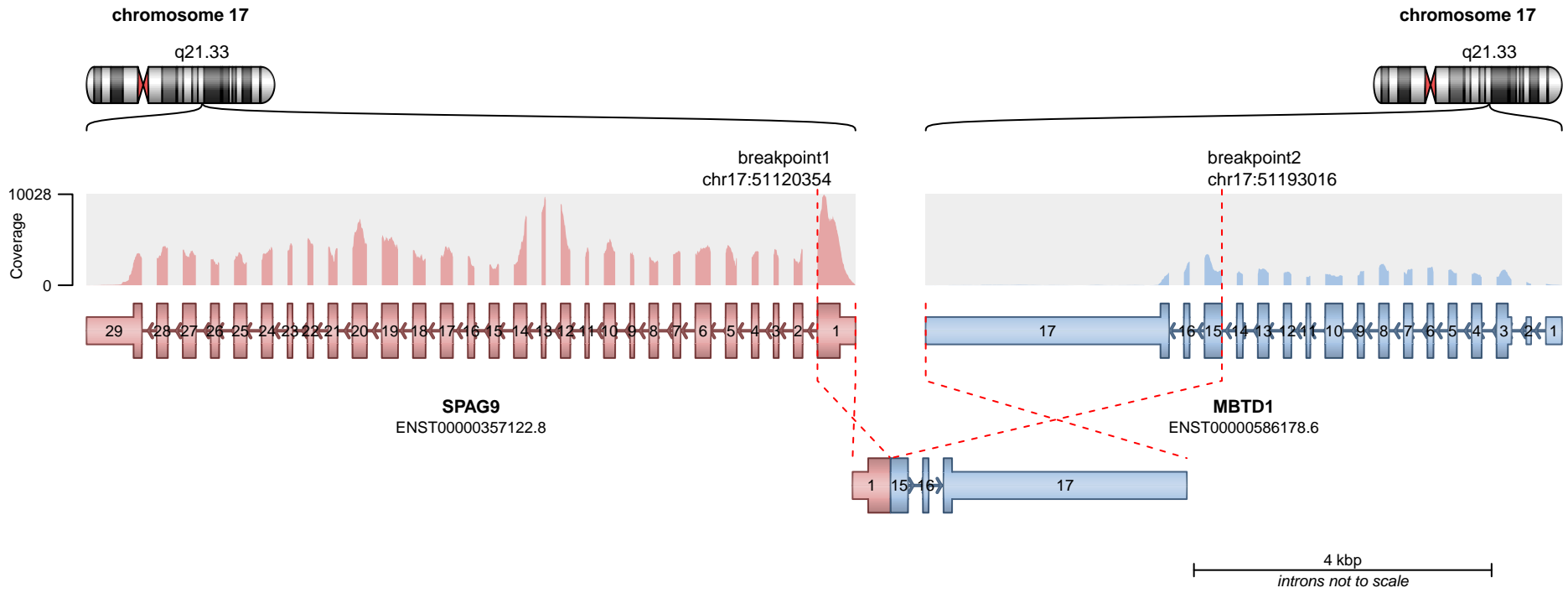

**RETAINED PROTEIN DOMAINS**  
reading frame unclear

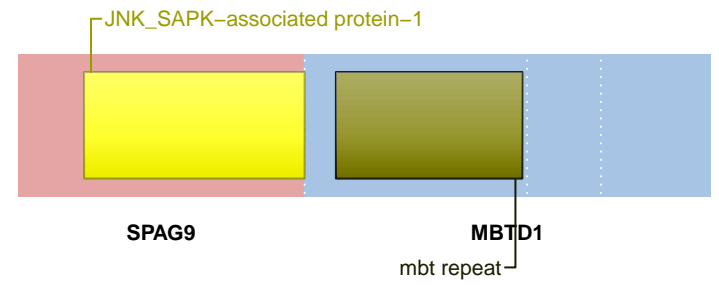

**SUPPORTING READ COUNT**

Split reads = 6  
Discordant mates = 0

- translocation
- duplication
- deletion
- inversion

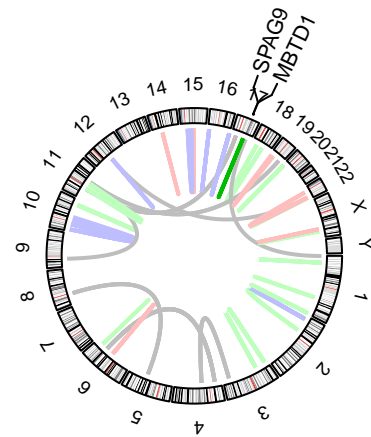
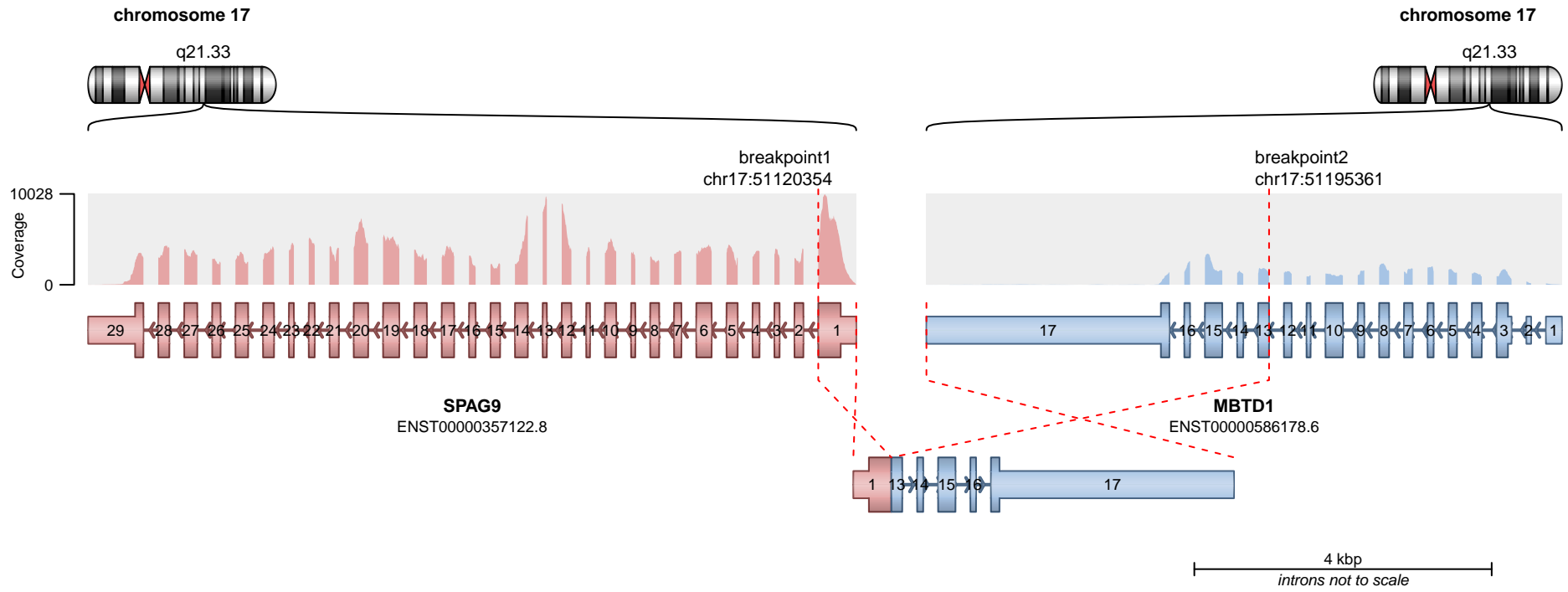

**RETAINED PROTEIN DOMAINS**  
reading frame unclear

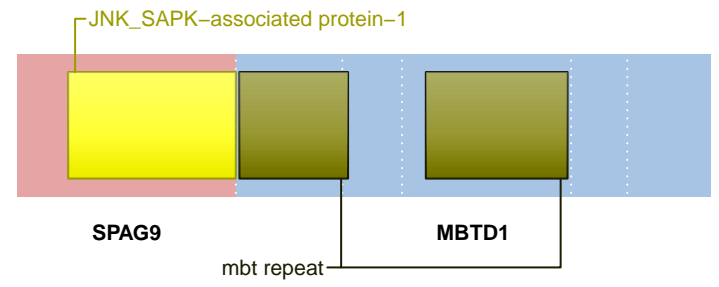

**SUPPORTING READ COUNT**

Split reads = 4  
Discordant mates = 2

- translocation
- duplication
- deletion
- inversion

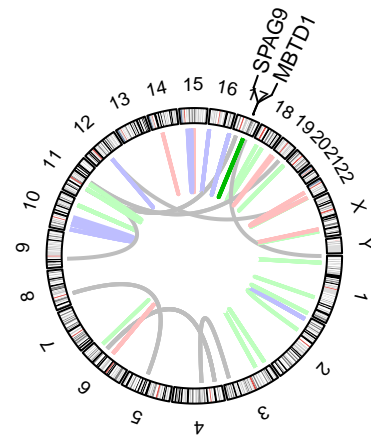
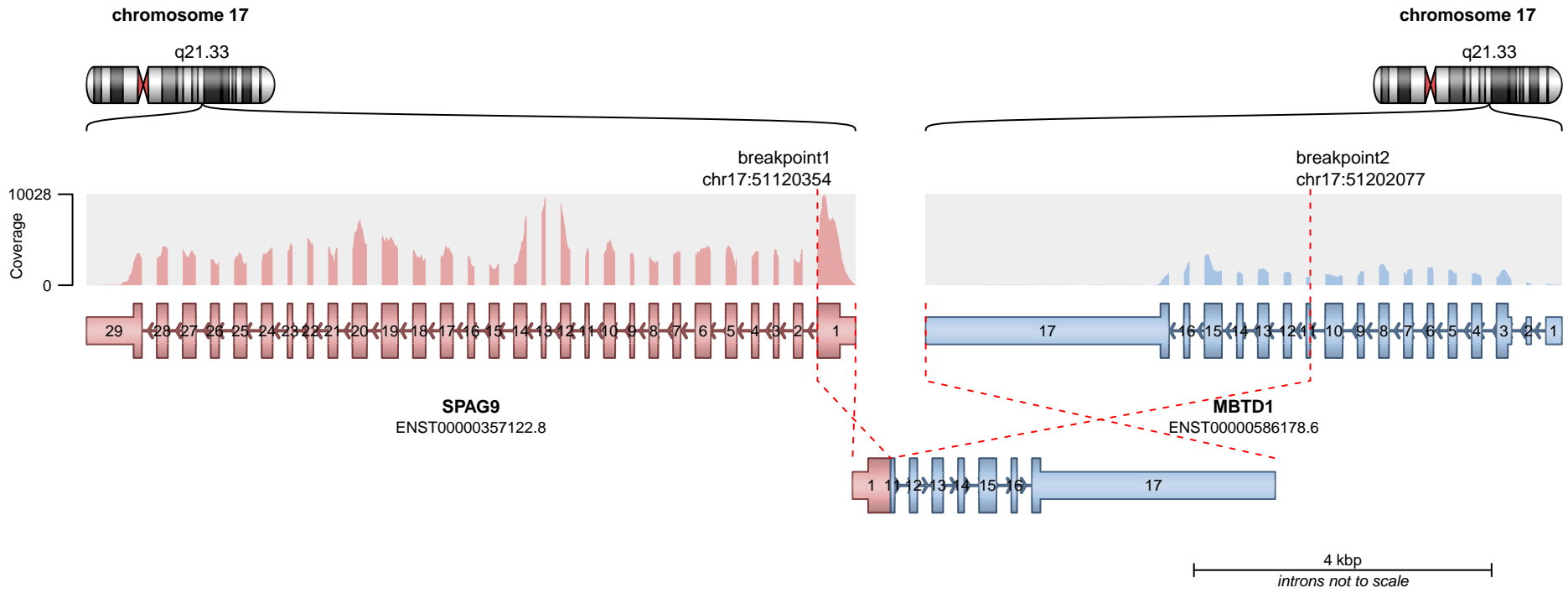

**RETAINED PROTEIN DOMAINS**  
reading frame unclear

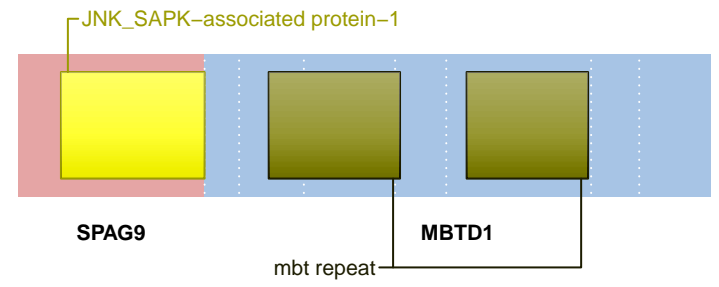

**SUPPORTING READ COUNT**

Split reads = 2  
Discordant mates = 2

- translocation
- duplication
- deletion
- inversion

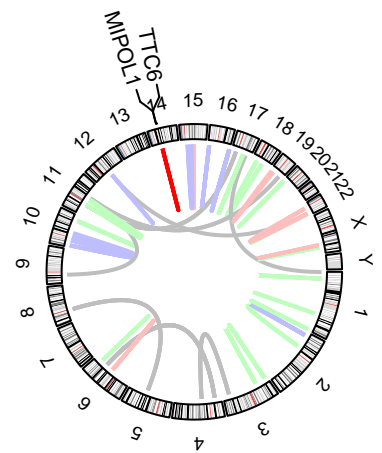
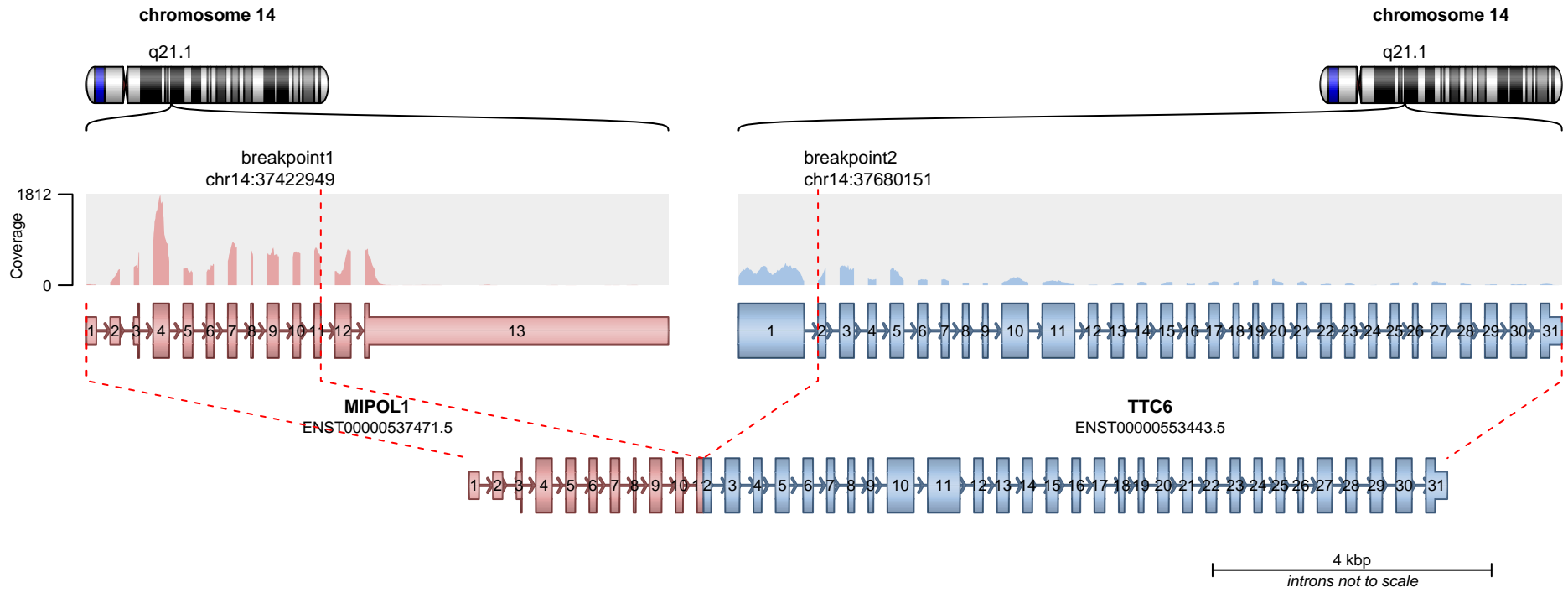

— translocation — deletion  
— duplication — inversion

**RETAINED PROTEIN DOMAINS**  
reading frame unclear

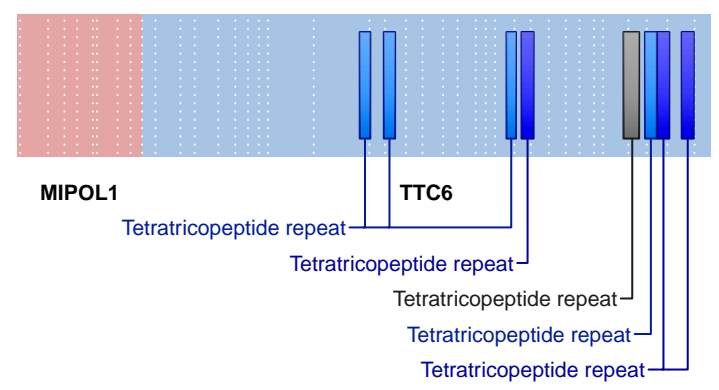

**SUPPORTING READ COUNT**

Split reads = 21  
Discordant mates = 3

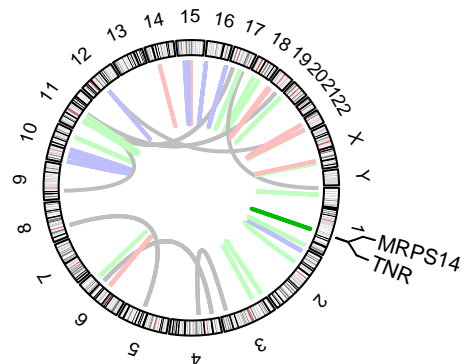
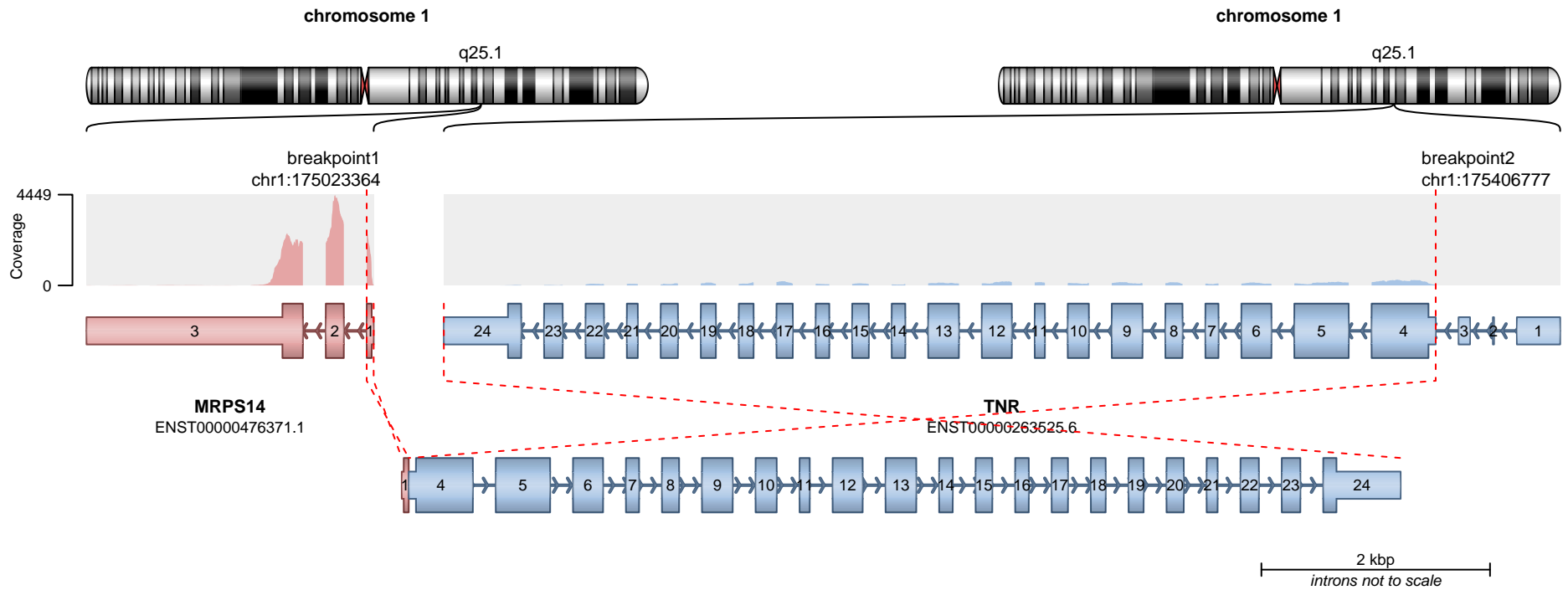

**RETAINED PROTEIN DOMAINS**  
reading frame unclear

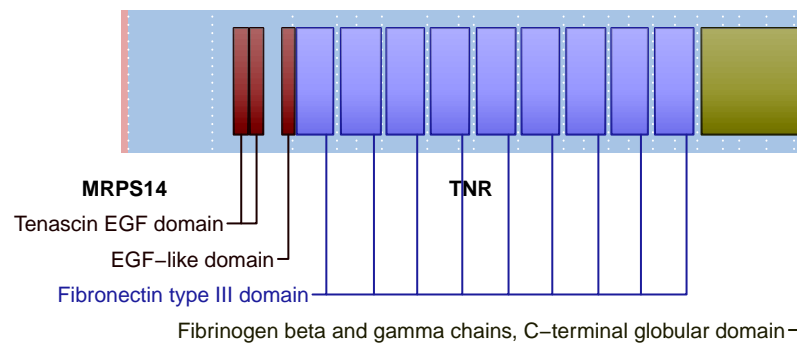

**SUPPORTING READ COUNT**

Split reads = 21  
Discordant mates = 0

— translocation — deletion  
— duplication — inversion

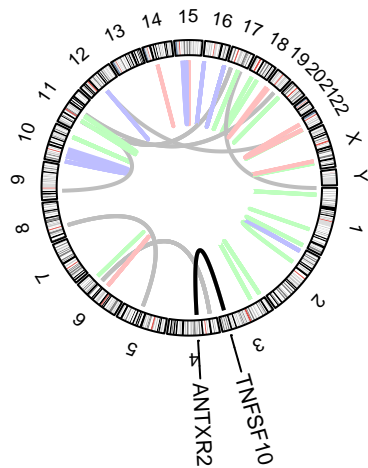
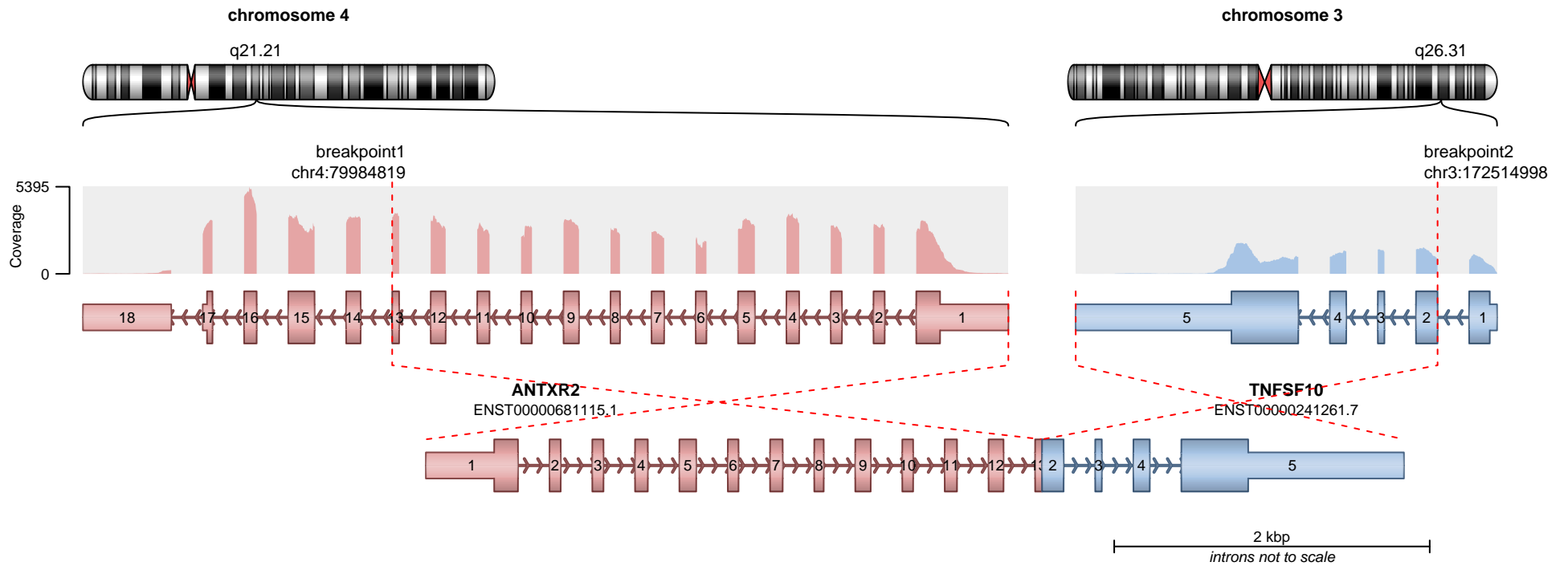

**RETAINED PROTEIN DOMAINS**  
reading frame unclear

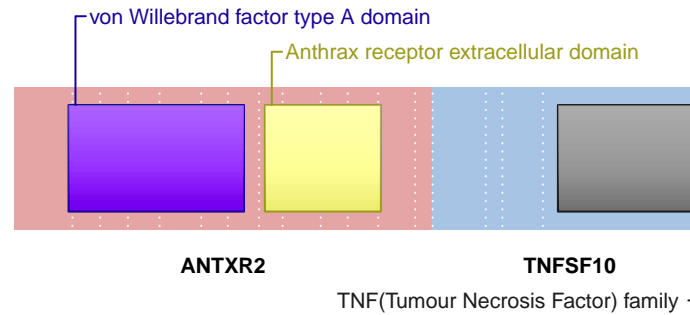

**SUPPORTING READ COUNT**

Split reads = 17  
Discordant mates = 0

— translocation — deletion  
— duplication — inversion

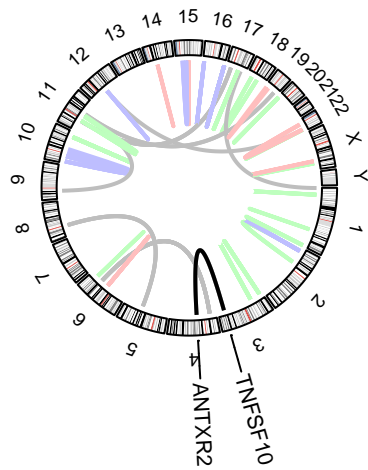
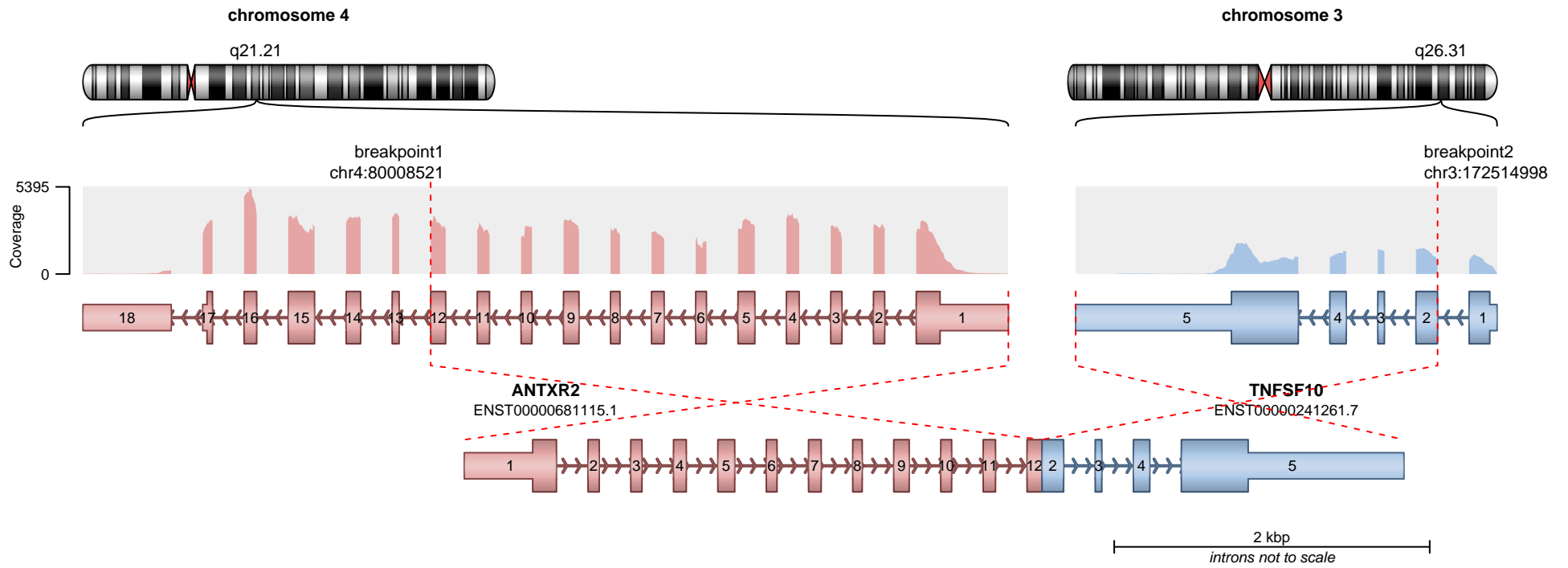

**RETAINED PROTEIN DOMAINS**  
reading frame unclear

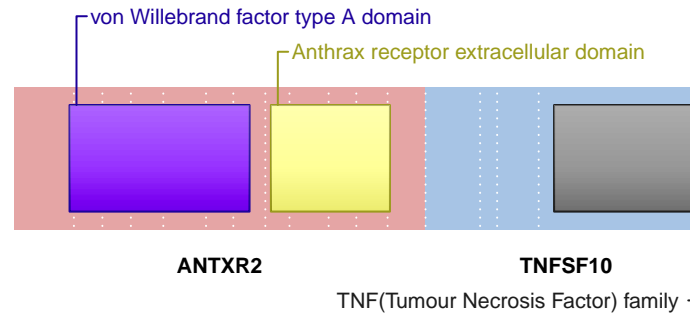

**SUPPORTING READ COUNT**

Split reads = 13  
Discordant mates = 0

— translocation — deletion  
— duplication — inversion

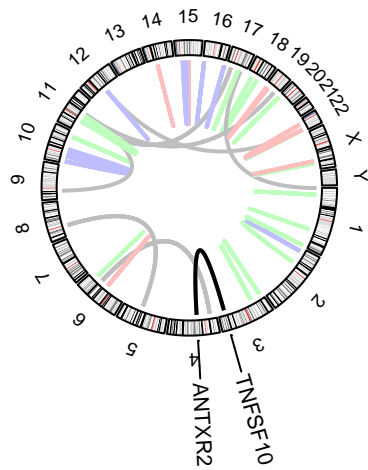
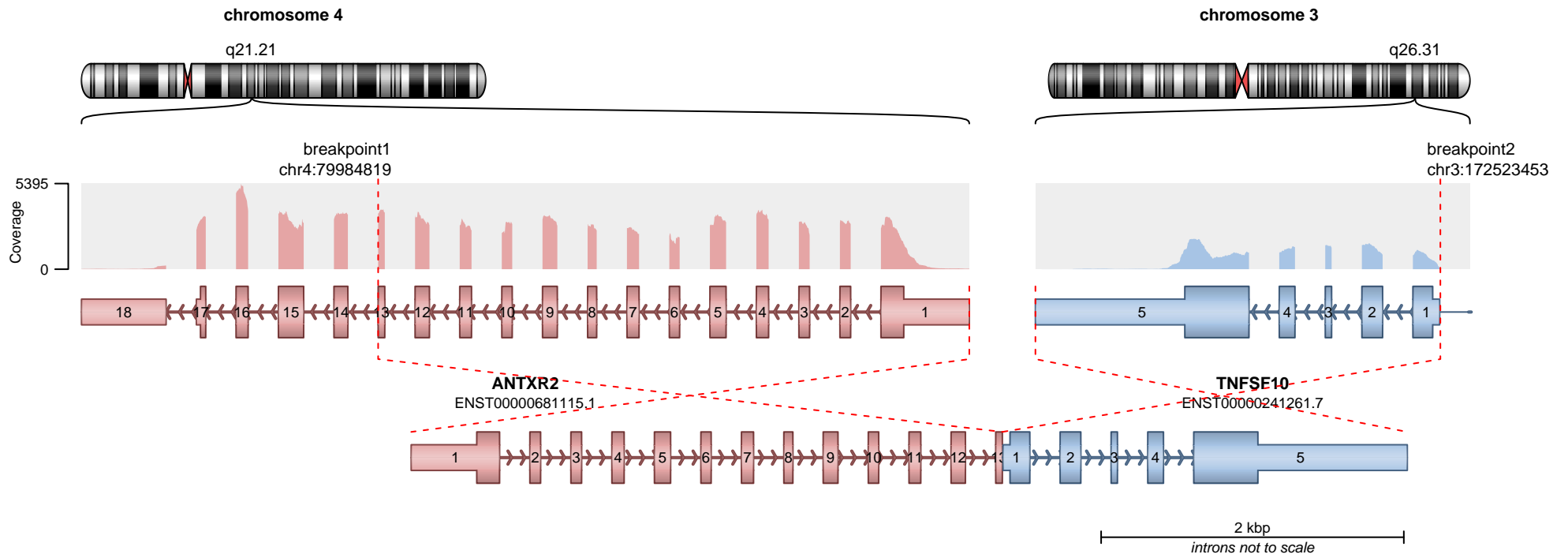

**RETAINED PROTEIN DOMAINS**  
reading frame unclear

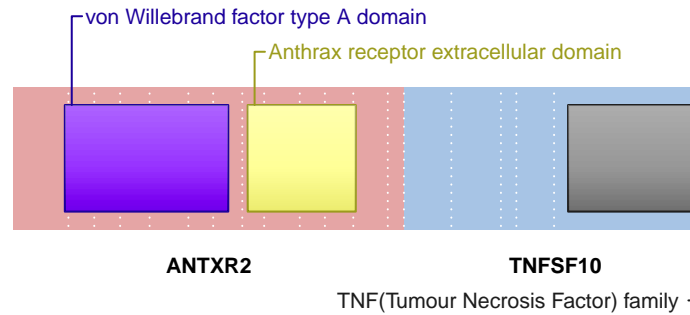

**SUPPORTING READ COUNT**

Split reads = 3  
Discordant mates = 0

— translocation — deletion  
— duplication — inversion

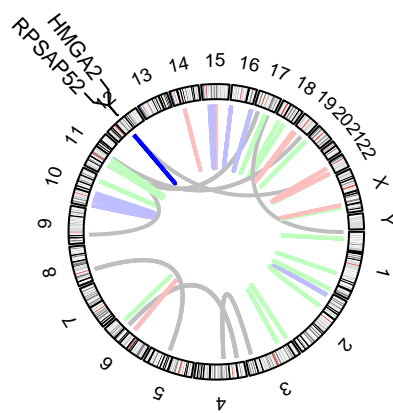
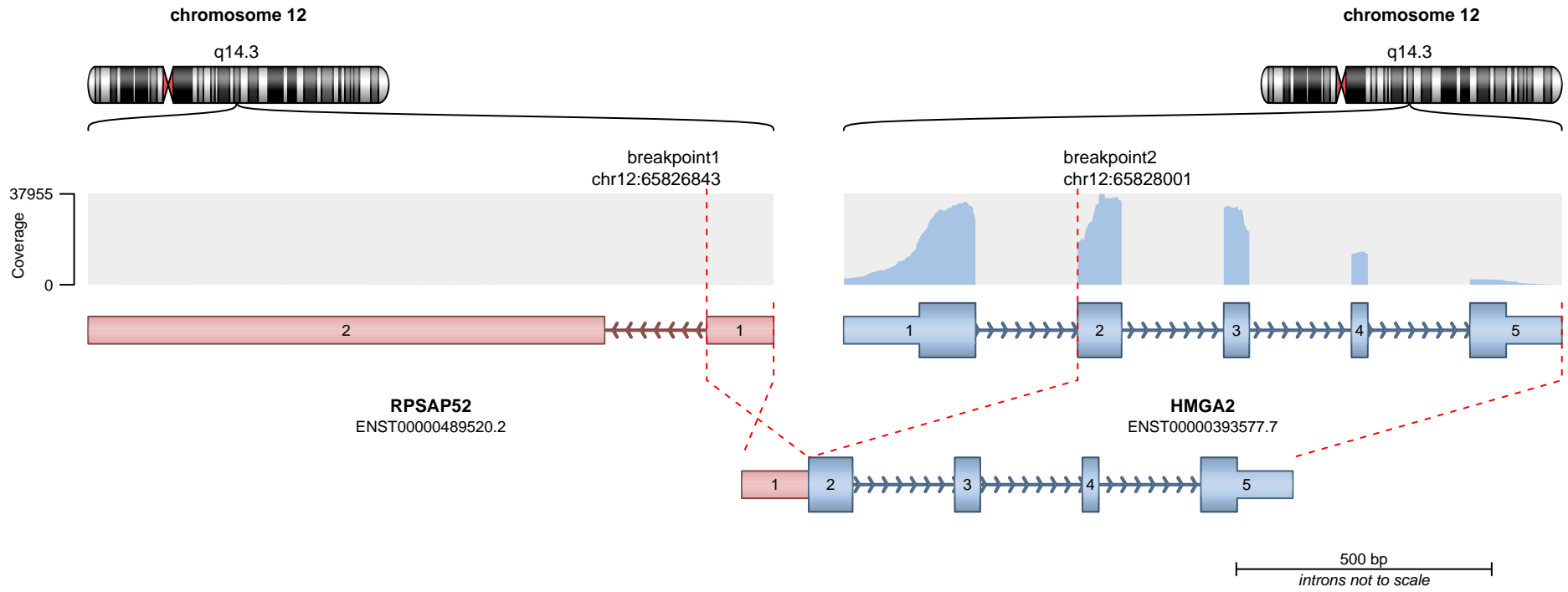

**RETAINED PROTEIN DOMAINS**  
reading frame unclear

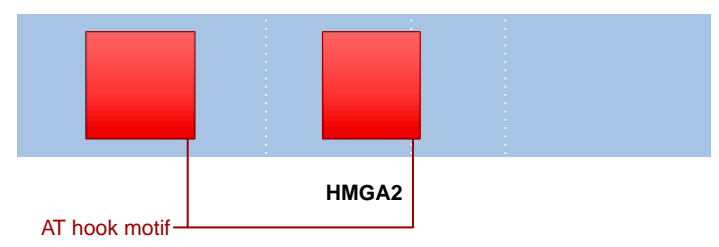

**SUPPORTING READ COUNT**

Split reads = 14  
Discordant mates = 0

— translocation    — deletion  
— duplication    — inversion

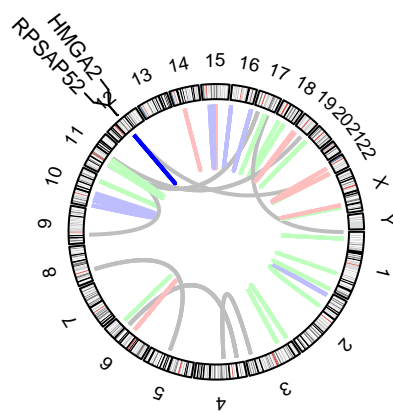
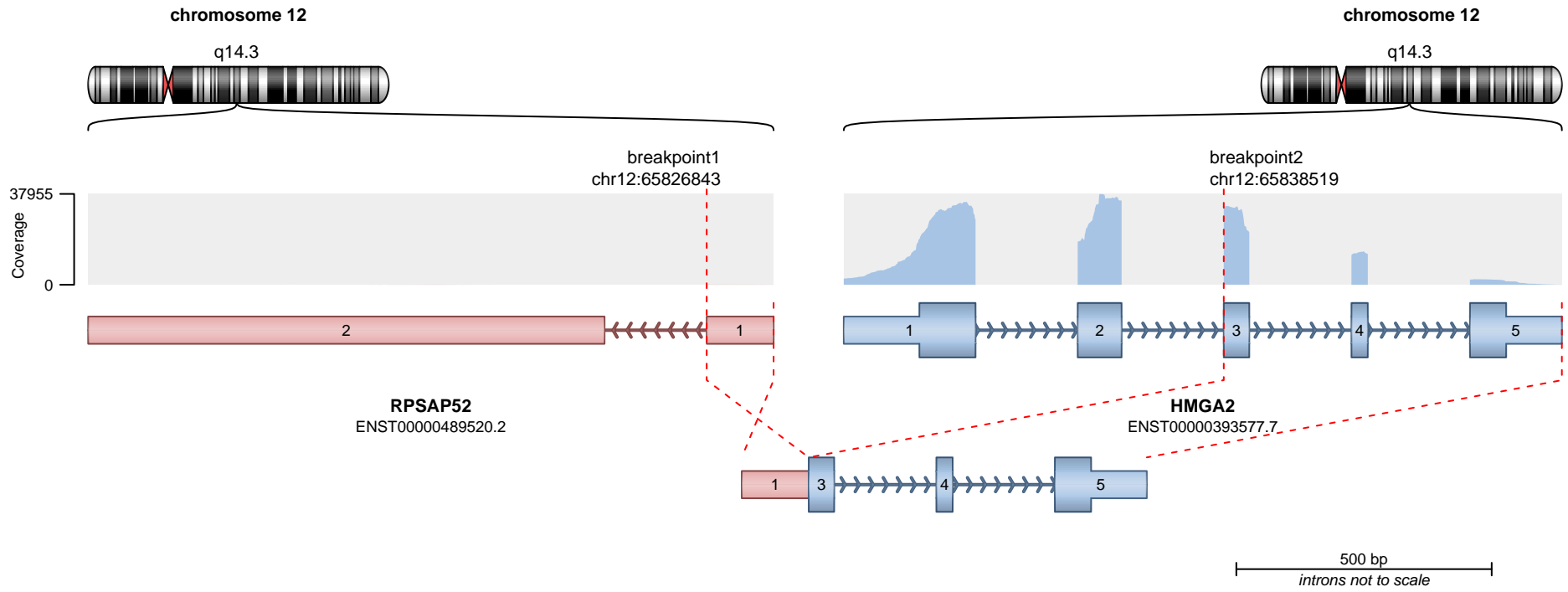

**RETAINED PROTEIN DOMAINS**  
reading frame unclear

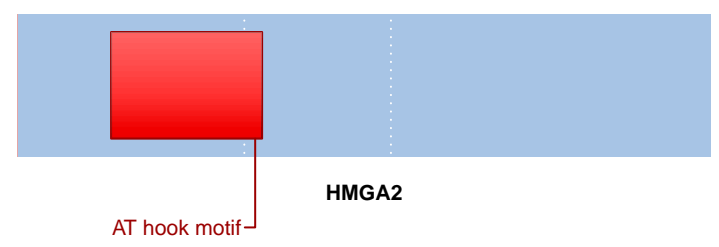

**SUPPORTING READ COUNT**

Split reads = 1  
Discordant mates = 0

— translocation    — deletion  
— duplication    — inversion

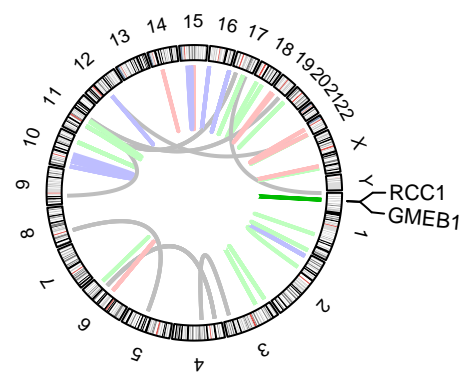
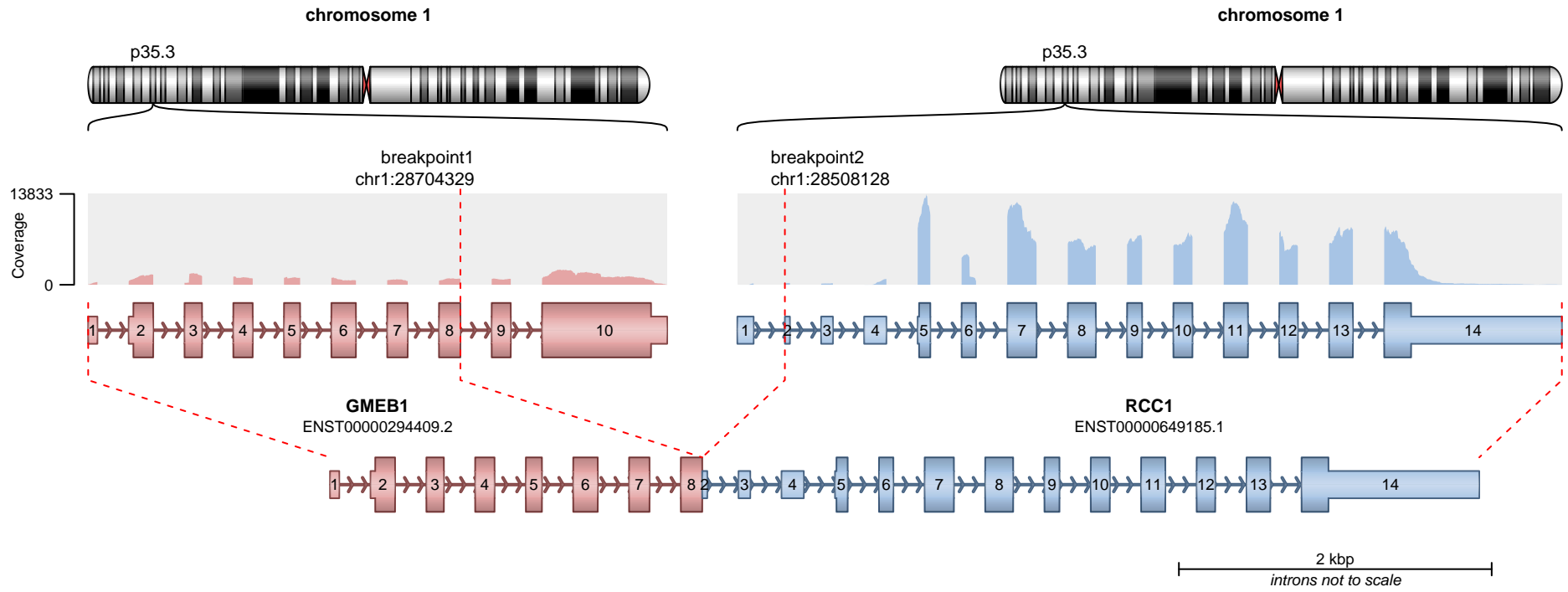

**RETAINED PROTEIN DOMAINS**  
reading frame unclear

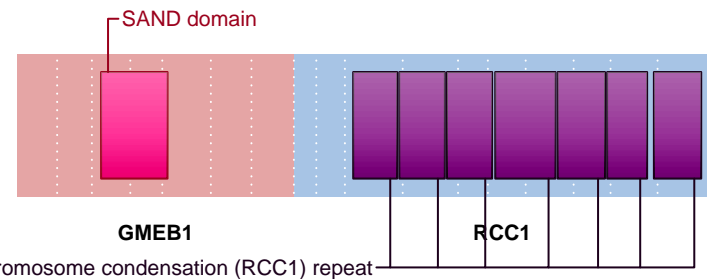

**SUPPORTING READ COUNT**

Split reads = 12  
Discordant mates = 0

- translocation
- duplication
- deletion
- inversion

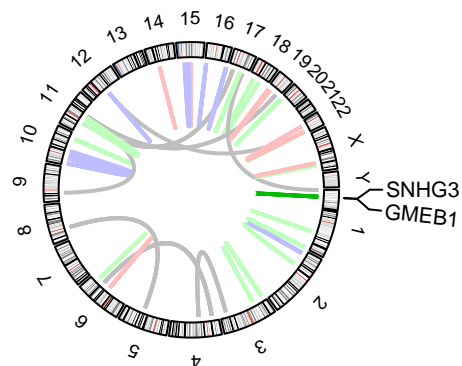
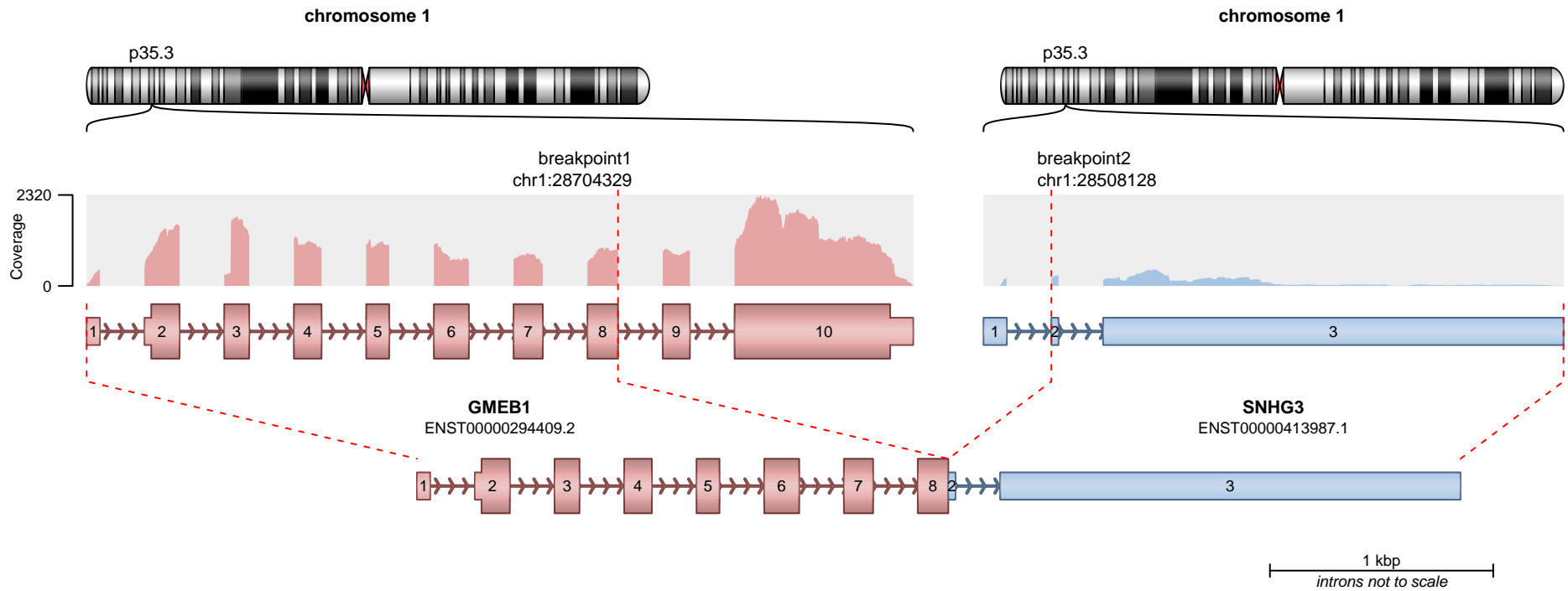

**RETAINED PROTEIN DOMAINS**  
reading frame unclear

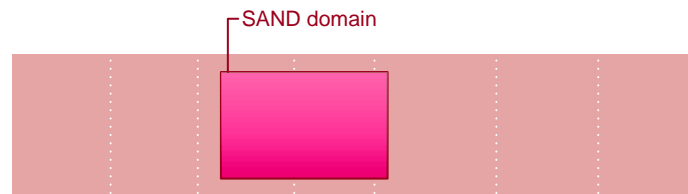

**SUPPORTING READ COUNT**

Split reads = 12  
Discordant mates = 0

- translocation
- duplication
- deletion
- inversion

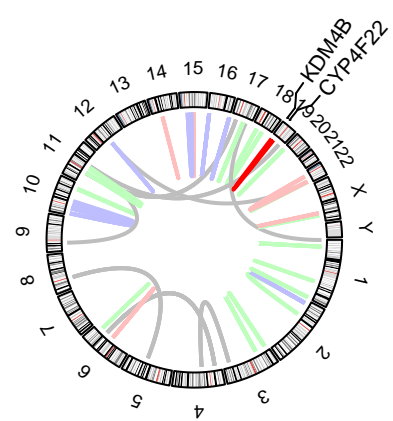
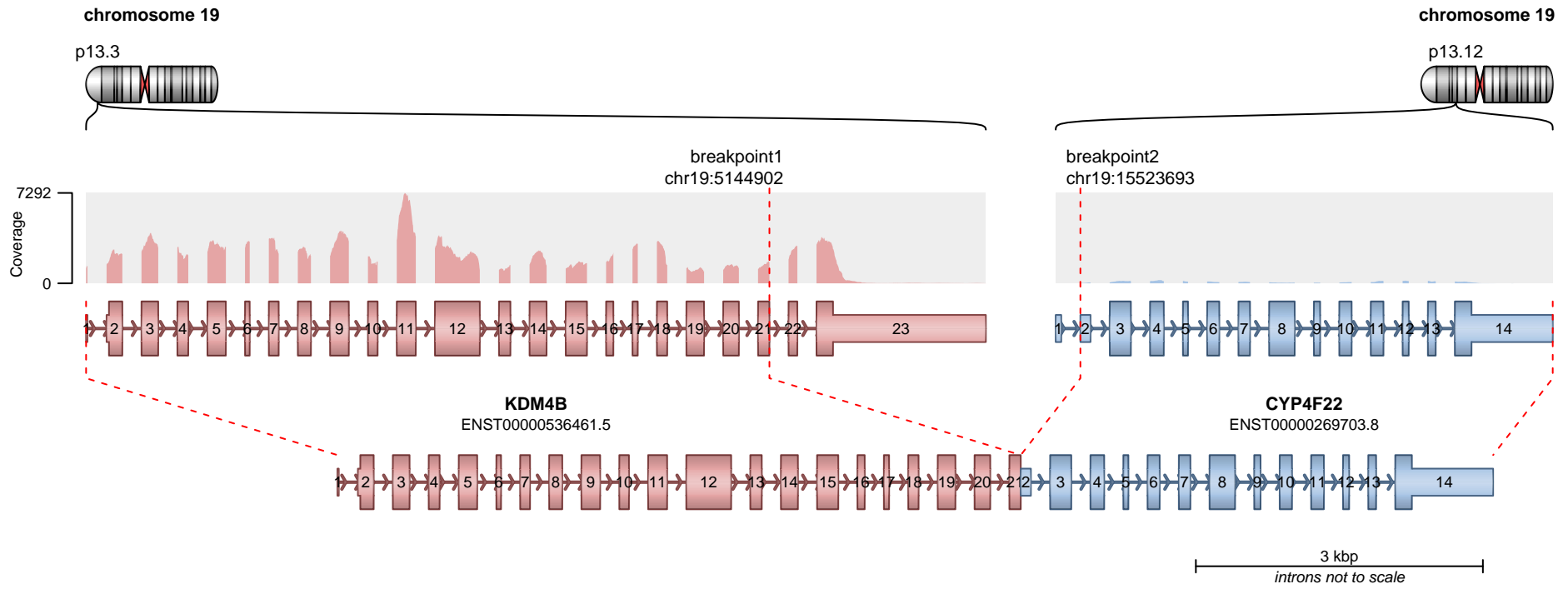

**RETAINED PROTEIN DOMAINS**  
reading frame unclear

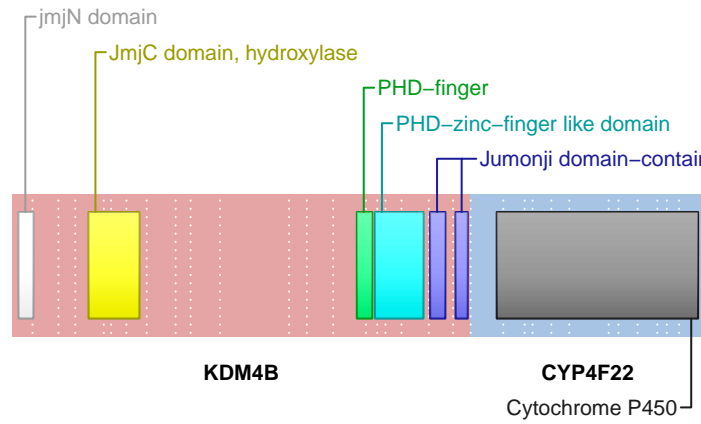

**SUPPORTING READ COUNT**

Split reads = 11  
Discordant mates = 0

- translocation
- duplication
- deletion
- inversion

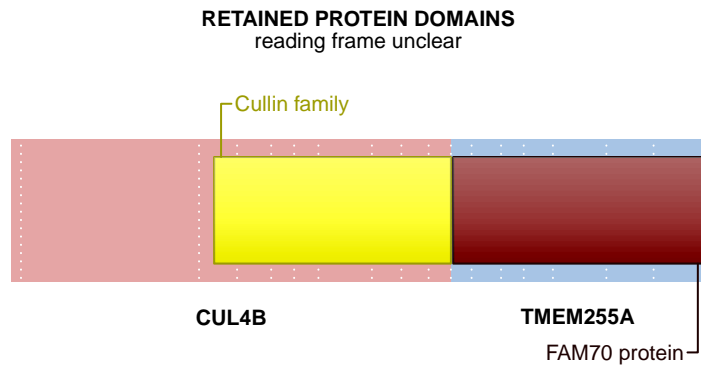
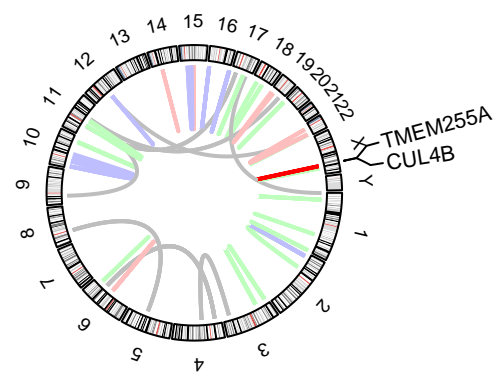
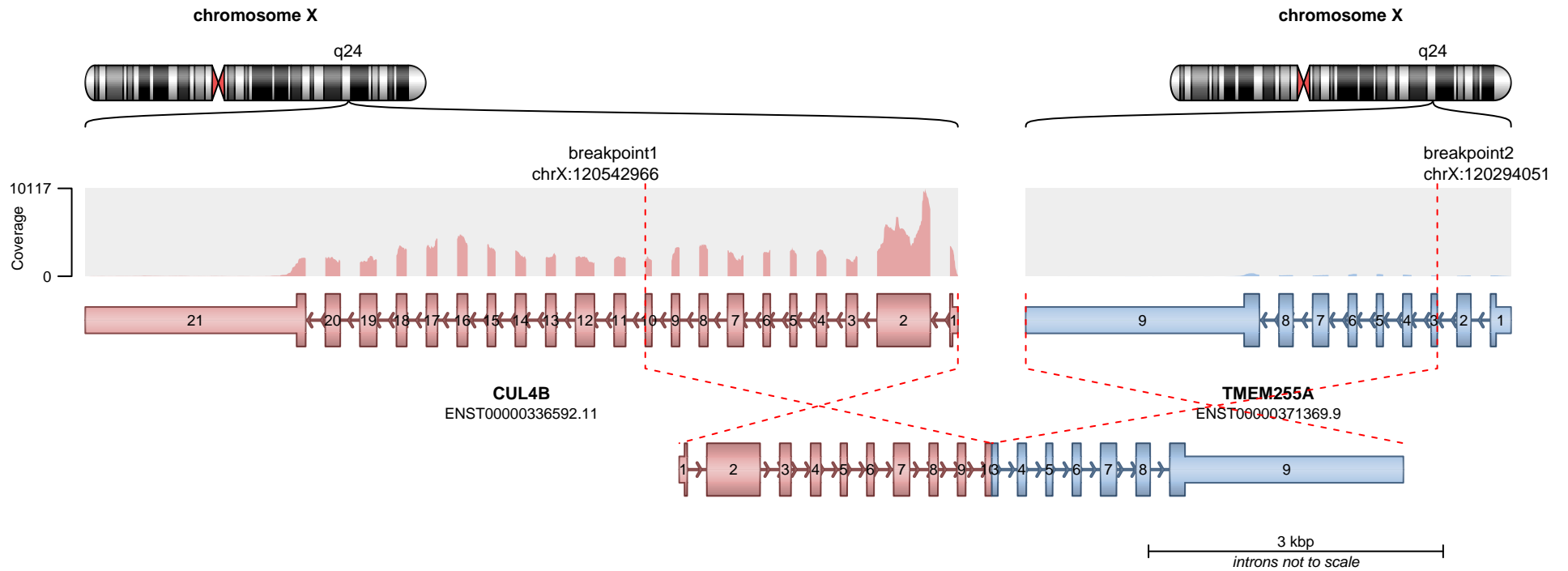

**SUPPORTING READ COUNT**

Split reads = 10  
Discordant mates = 1

— translocation — deletion  
— duplication — inversion

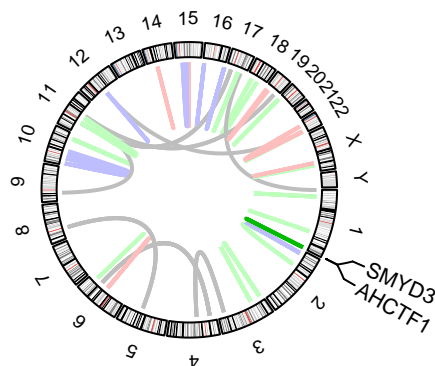
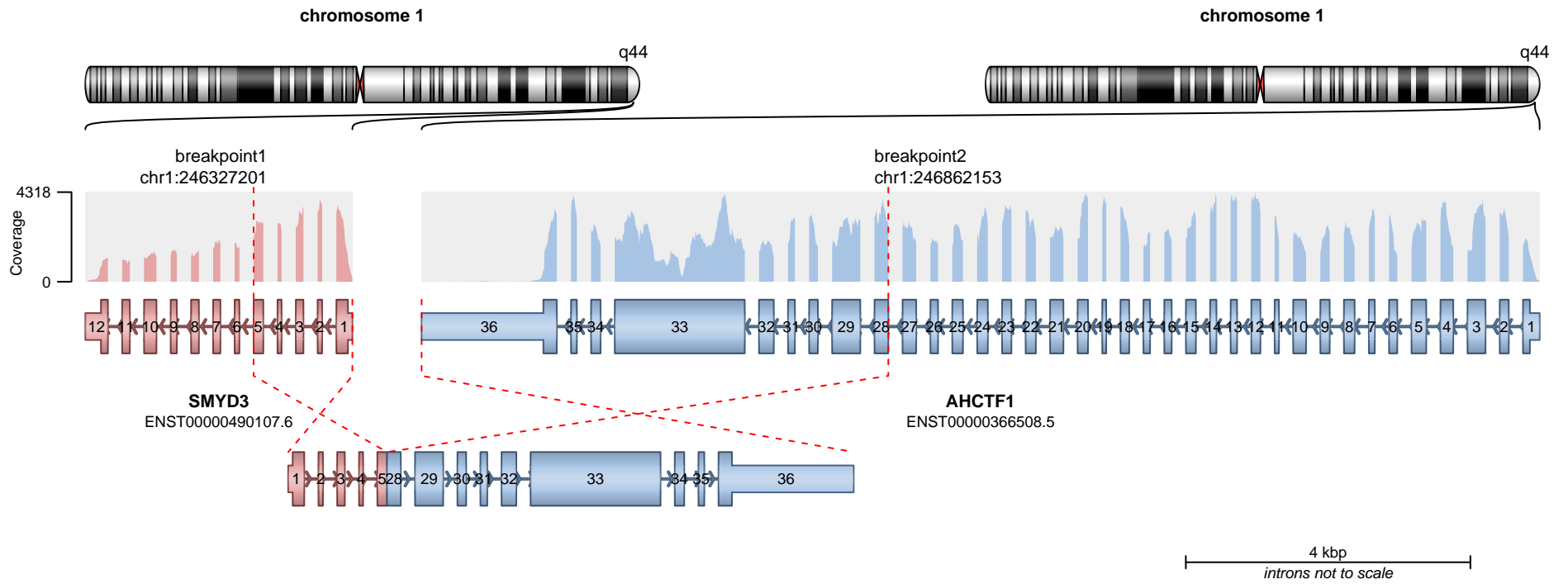

**RETAINED PROTEIN DOMAINS**  
reading frame unclear

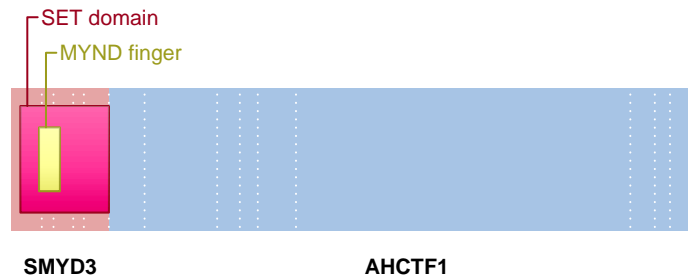

**SUPPORTING READ COUNT**

Split reads = 9  
Discordant mates = 0

- translocation
- duplication
- deletion
- inversion

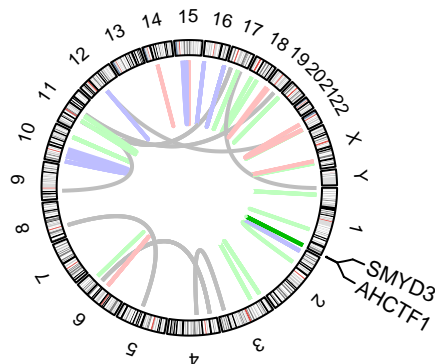
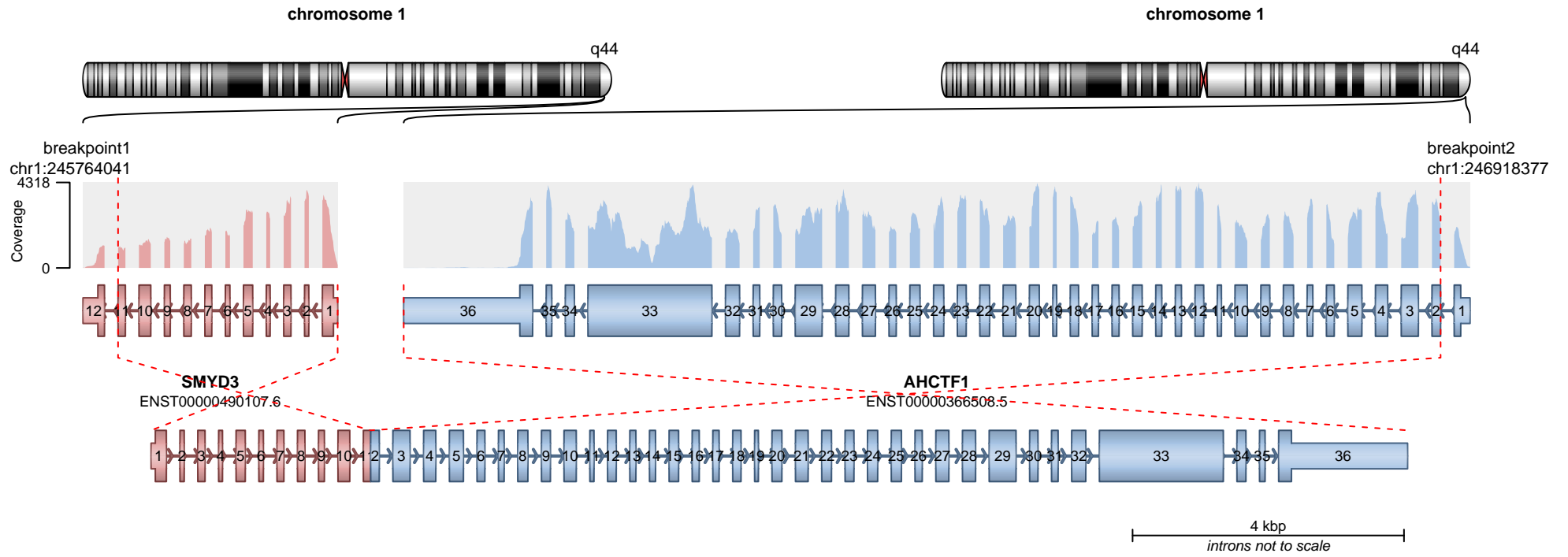

**RETAINED PROTEIN DOMAINS**  
reading frame unclear

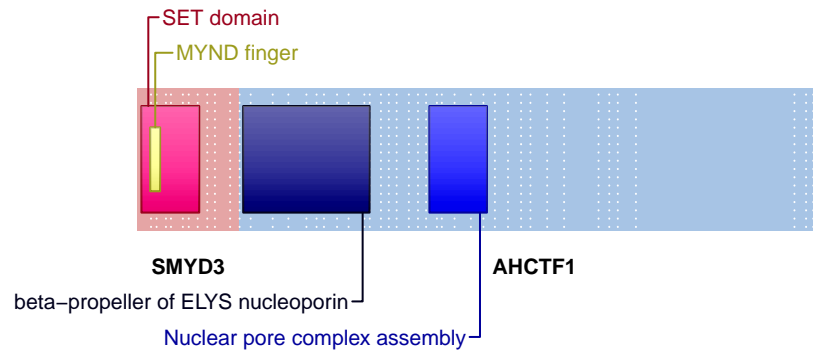

**SUPPORTING READ COUNT**

Split reads = 3  
Discordant mates = 0

- translocation
- duplication
- deletion
- inversion

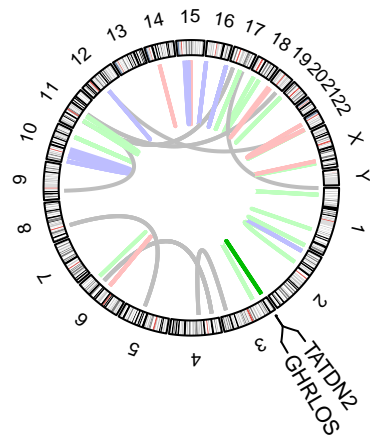
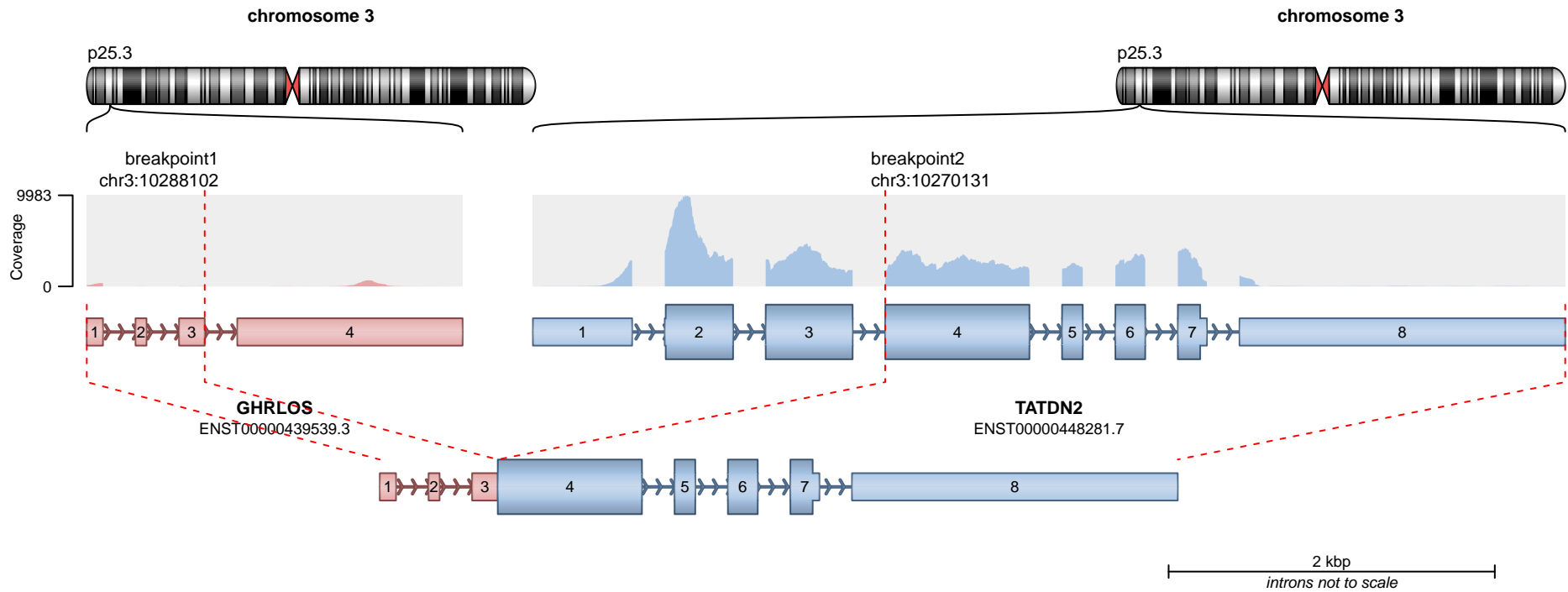

**RETAINED PROTEIN DOMAINS**  
reading frame unclear

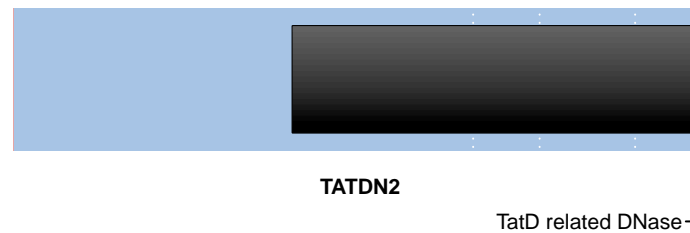

**SUPPORTING READ COUNT**

Split reads = 8  
Discordant mates = 0

— translocation — deletion  
— duplication — inversion

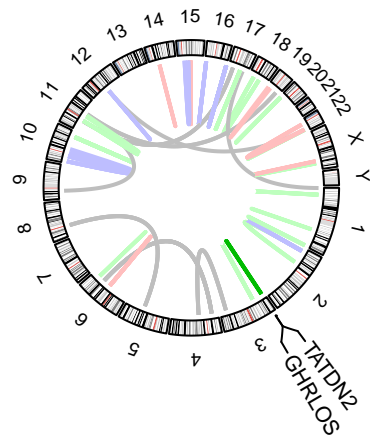
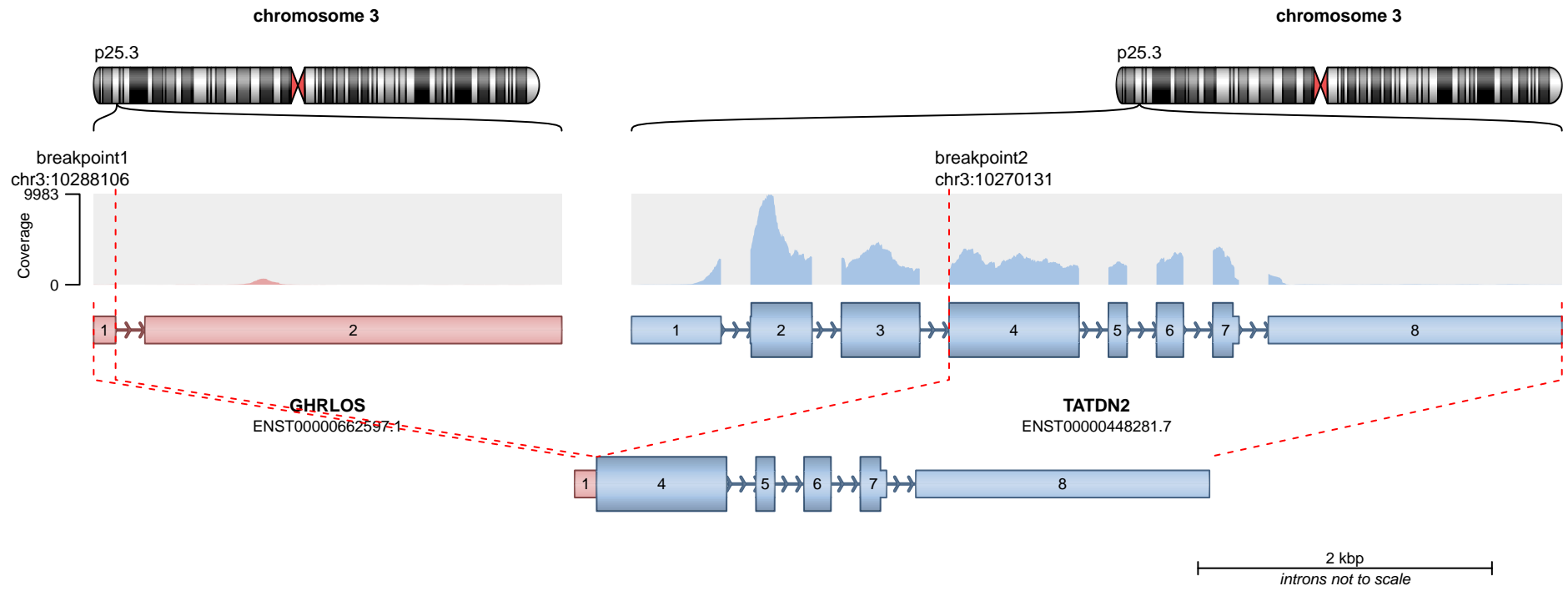

— translocation — deletion  
— duplication — inversion

**RETAINED PROTEIN DOMAINS**  
reading frame unclear

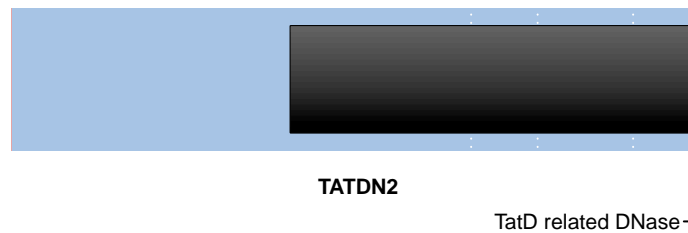

**SUPPORTING READ COUNT**

Split reads = 5  
Discordant mates = 0

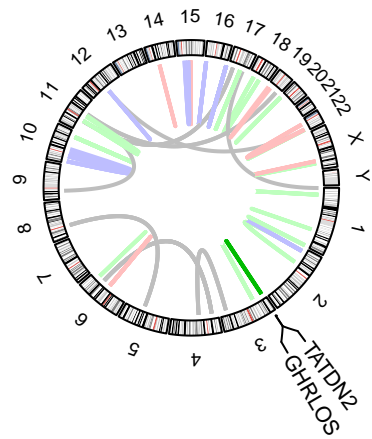
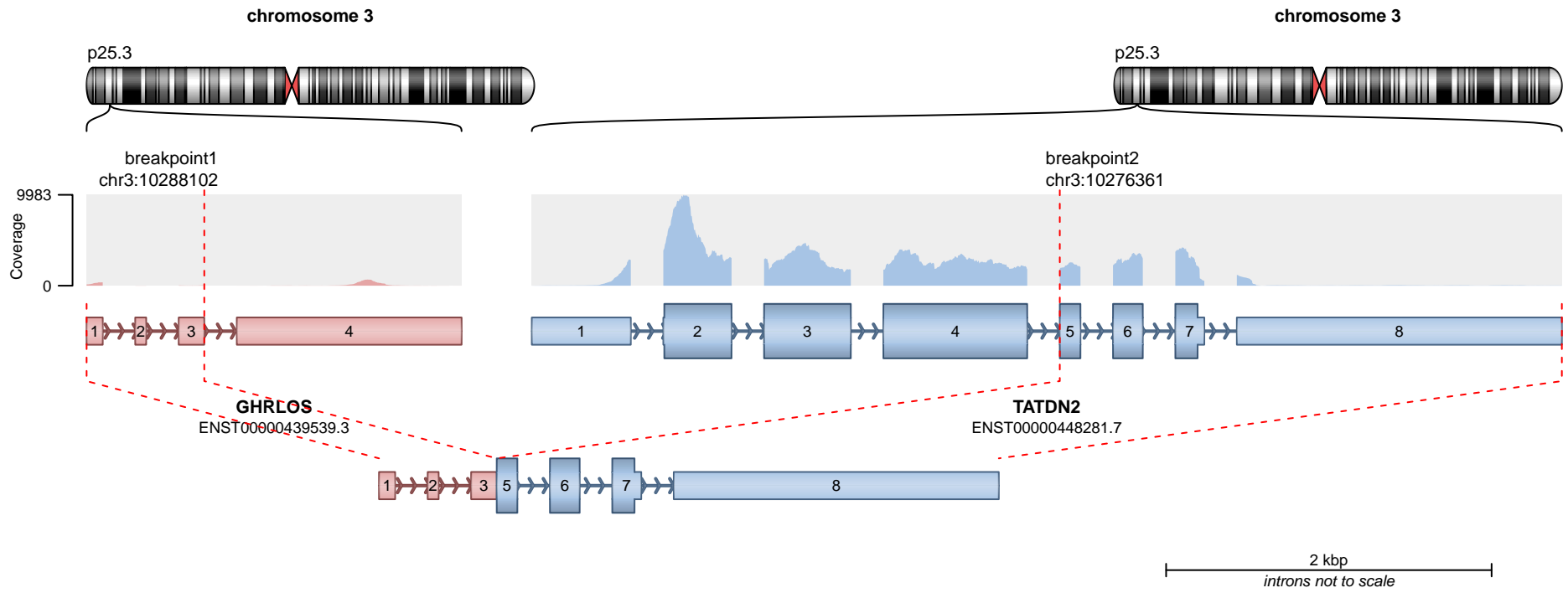

**RETAINED PROTEIN DOMAINS**  
reading frame unclear



**TATDN2**

TatD related DNase

**SUPPORTING READ COUNT**

Split reads = 1  
Discordant mates = 0

— translocation — deletion  
— duplication — inversion

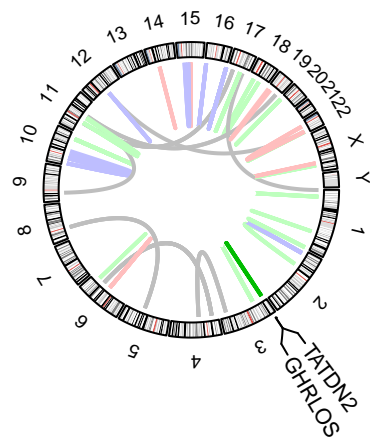
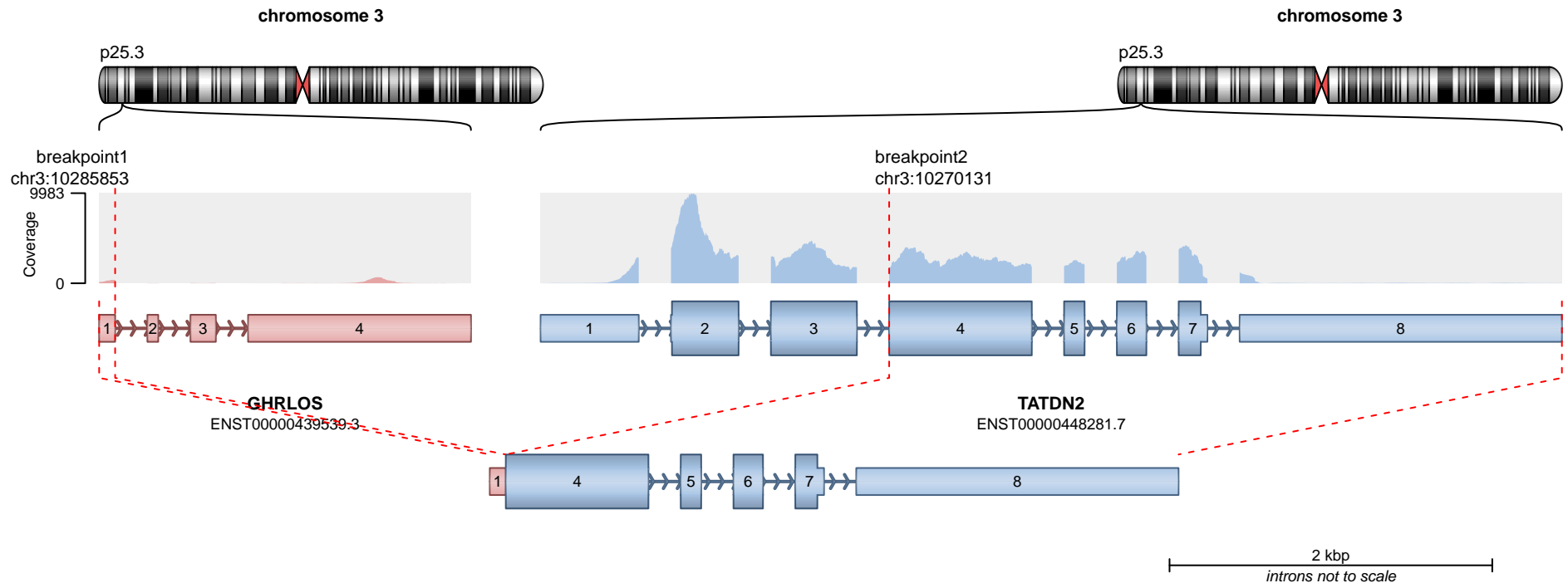

— translocation — deletion  
— duplication — inversion

**RETAINED PROTEIN DOMAINS**  
reading frame unclear

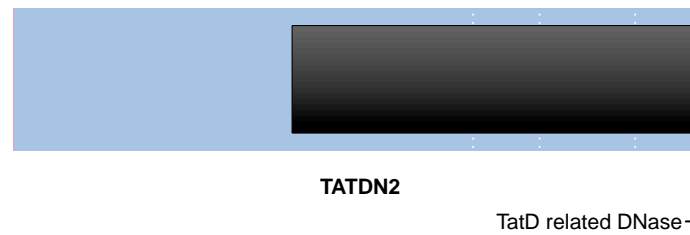

**SUPPORTING READ COUNT**

Split reads = 1  
Discordant mates = 0

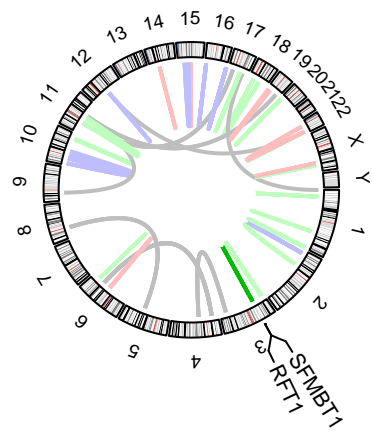
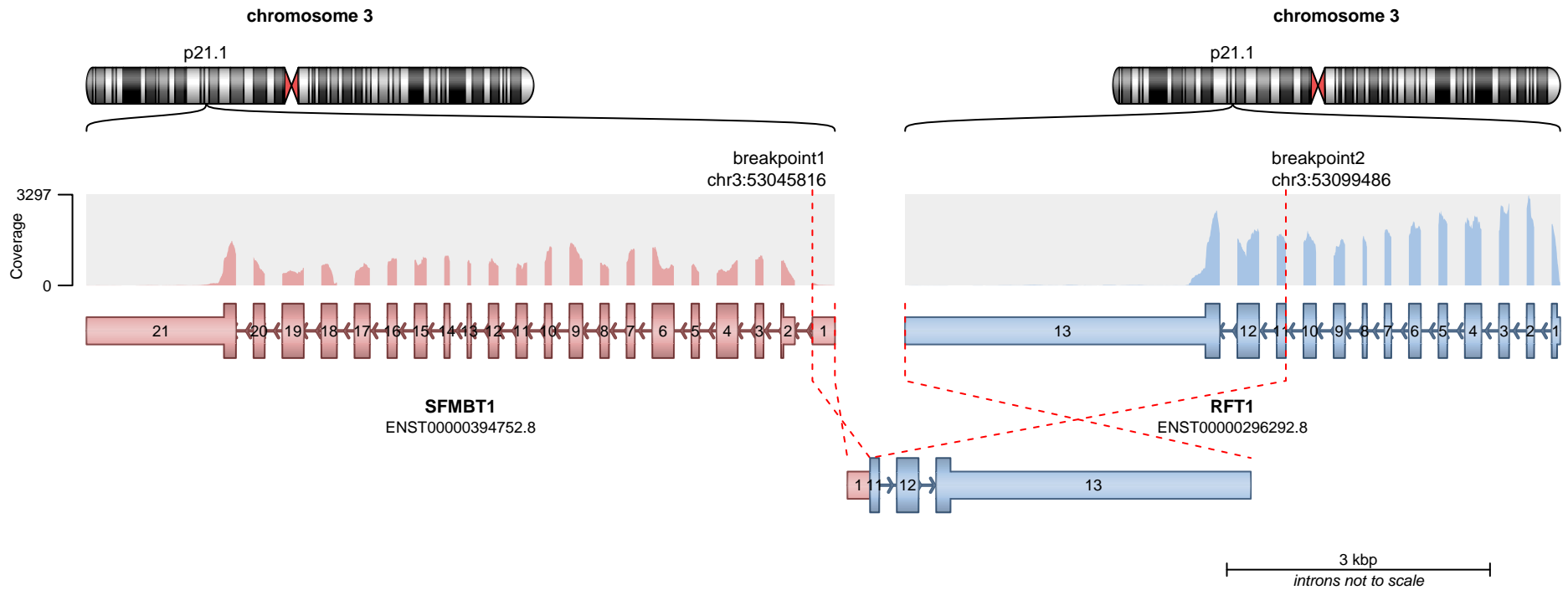

— translocation    — deletion  
— duplication    — inversion

**RETAINED PROTEIN DOMAINS**  
reading frame unclear

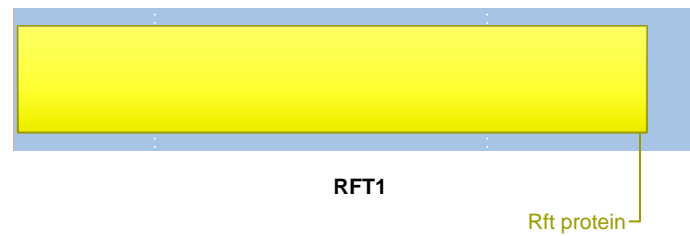

**SUPPORTING READ COUNT**

Split reads = 6  
Discordant mates = 0

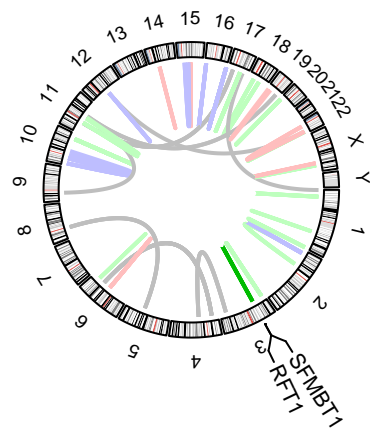
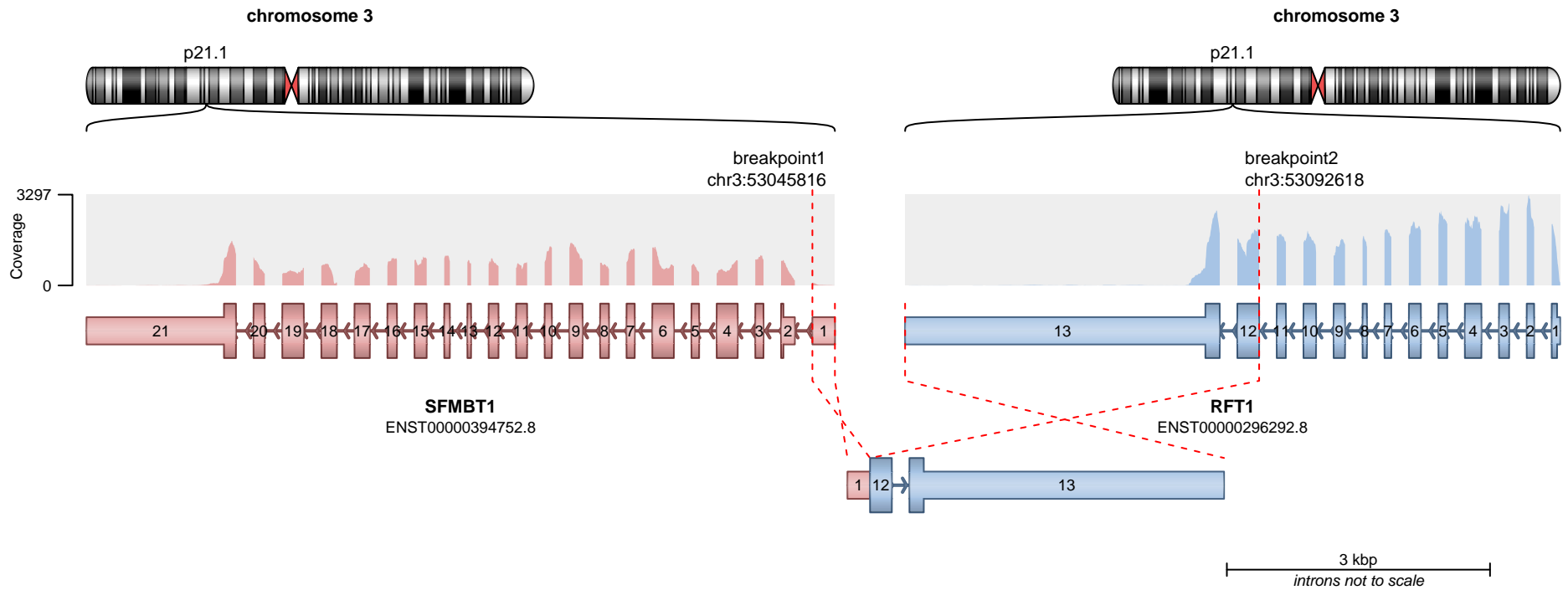

**RETAINED PROTEIN DOMAINS**  
reading frame unclear

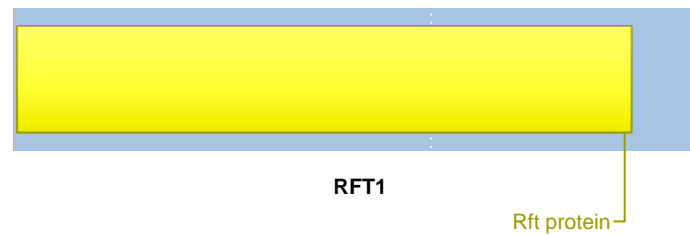

**SUPPORTING READ COUNT**

Split reads = 3  
Discordant mates = 0

— translocation — deletion  
— duplication — inversion

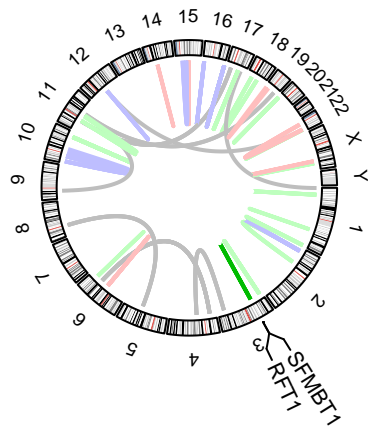
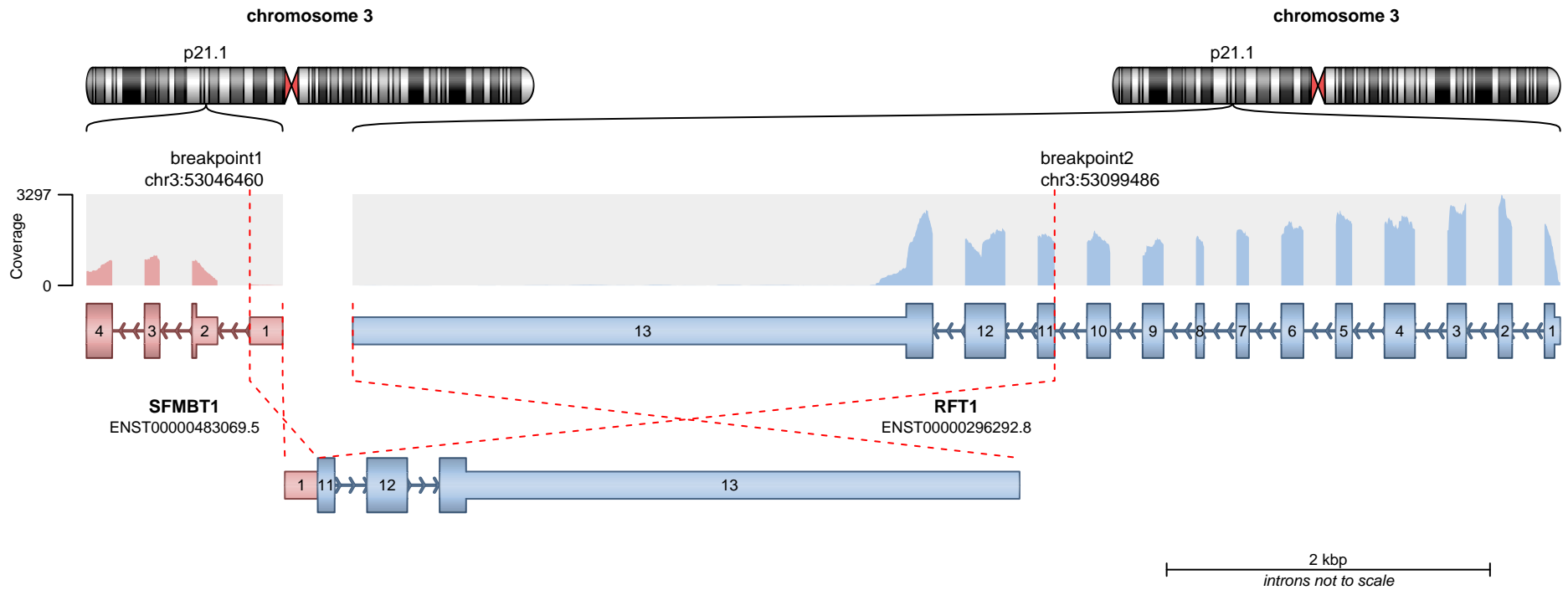

RETAINED PROTEIN DOMAINS  
reading frame unclear

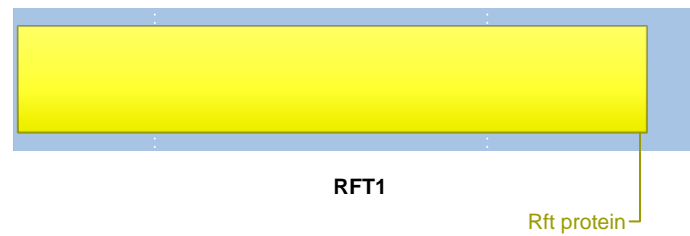

SUPPORTING READ COUNT

Split reads = 3  
Discordant mates = 0

— translocation — deletion  
— duplication — inversion

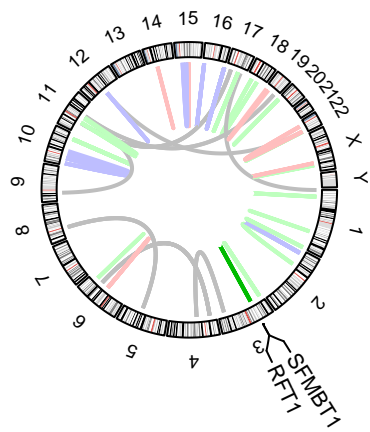
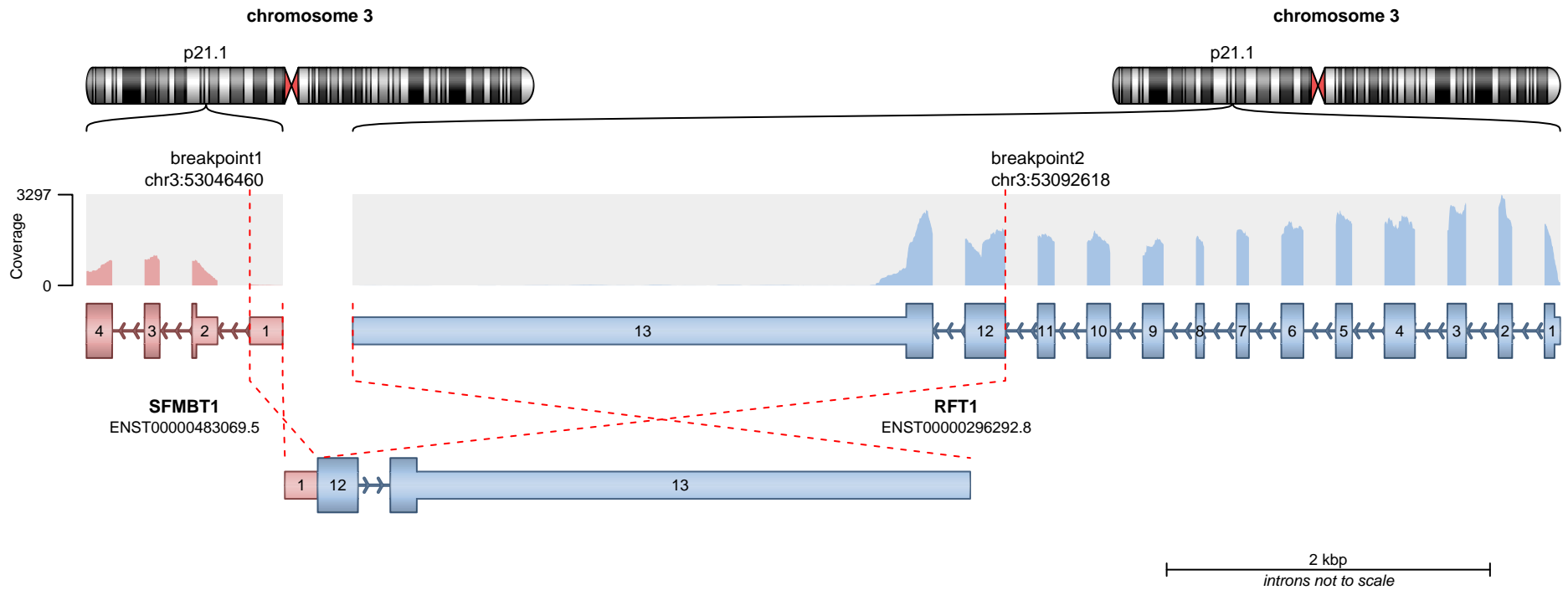

RETAINED PROTEIN DOMAINS  
reading frame unclear

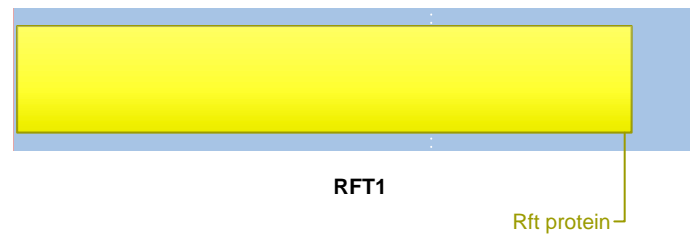

SUPPORTING READ COUNT

Split reads = 3  
Discordant mates = 0

— translocation — deletion  
— duplication — inversion