

— translocation — deletion  
— duplication — inversion

**RETAINED PROTEIN DOMAINS**  
reading frame unclear

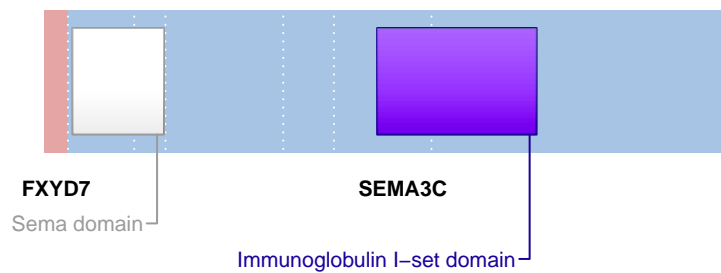

**SUPPORTING READ COUNT**

Split reads = 719  
Discordant mates = 0

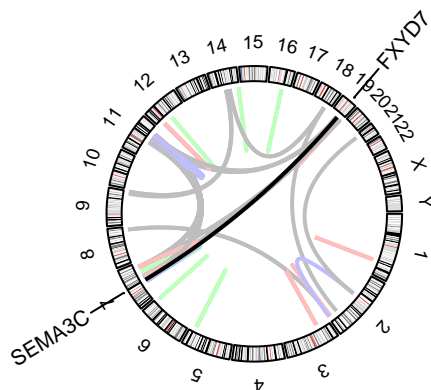
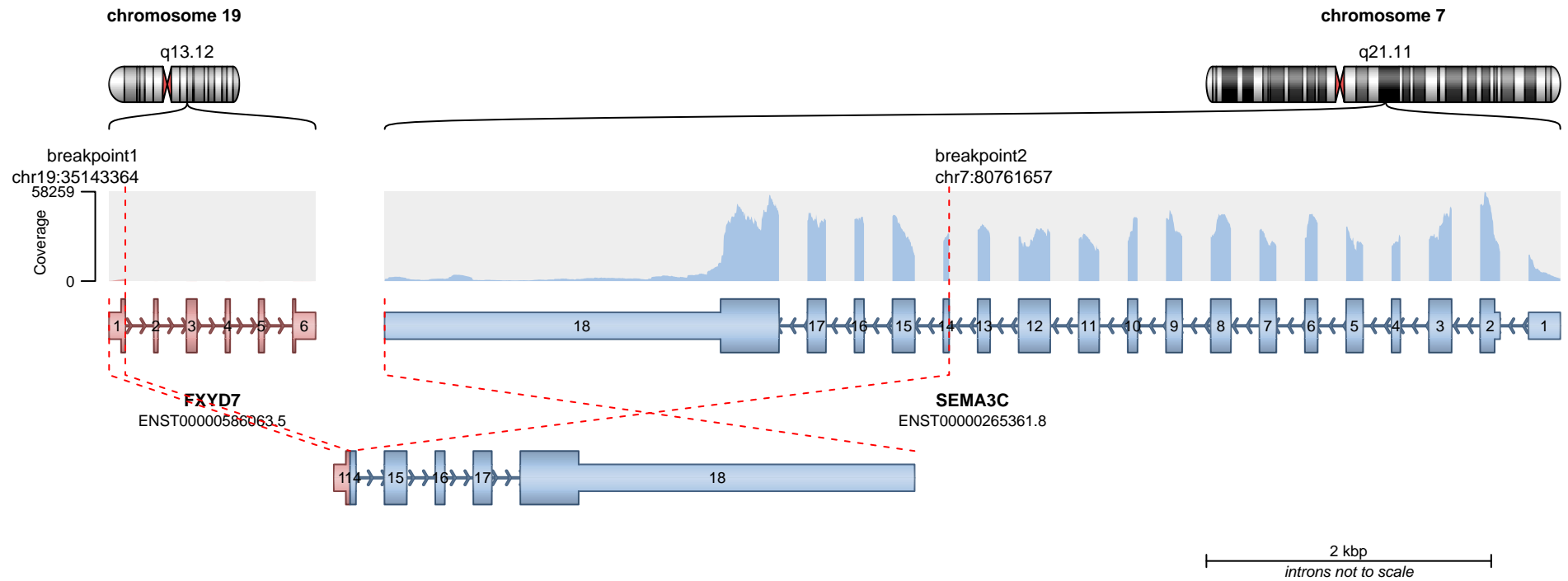

**RETAINED PROTEIN DOMAINS**  
reading frame unclear

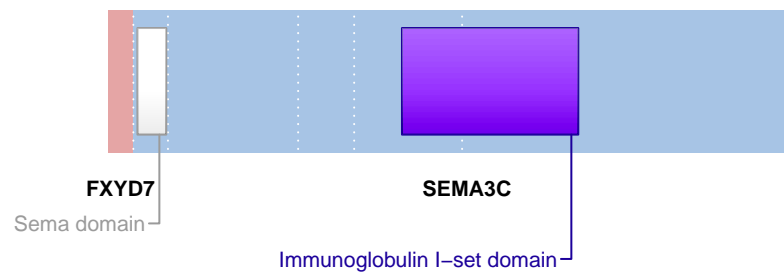

**SUPPORTING READ COUNT**

Split reads = 5  
Discordant mates = 0

- translocation
- duplication
- deletion
- inversion

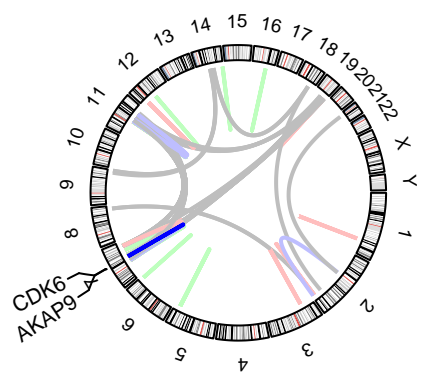
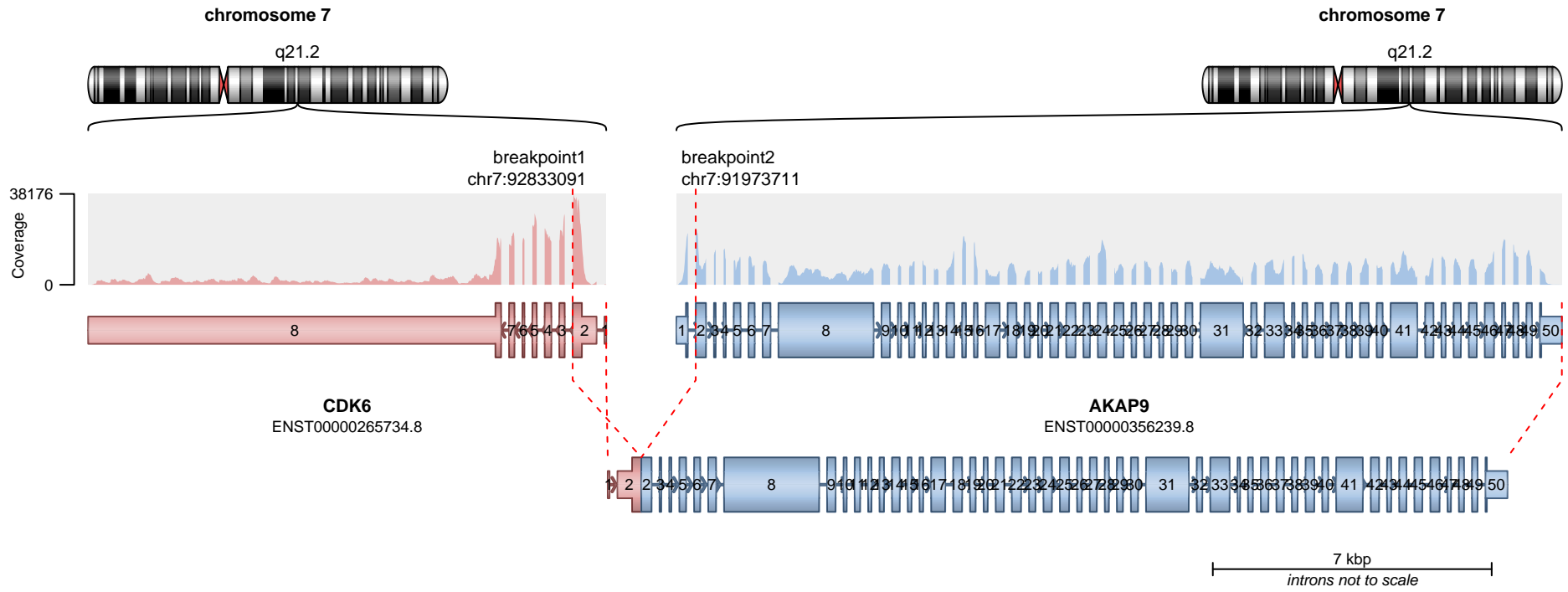

— translocation    — deletion  
— duplication    — inversion

**RETAINED PROTEIN DOMAINS**  
reading frame unclear

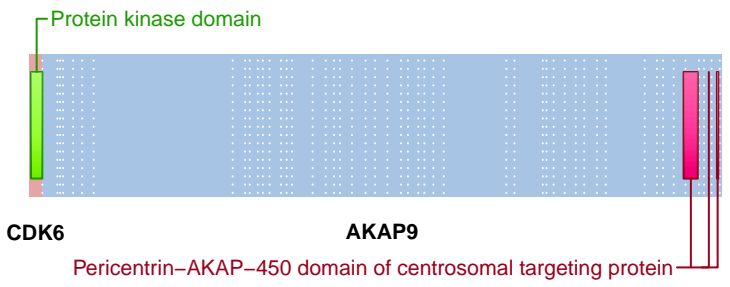

**SUPPORTING READ COUNT**

Split reads = 502  
Discordant mates = 3

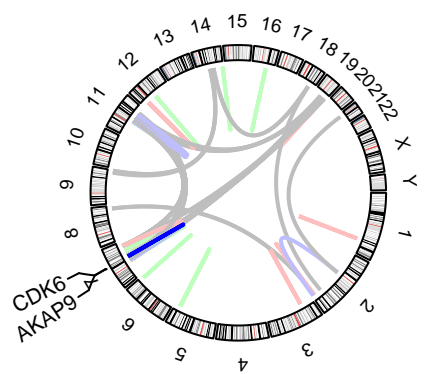
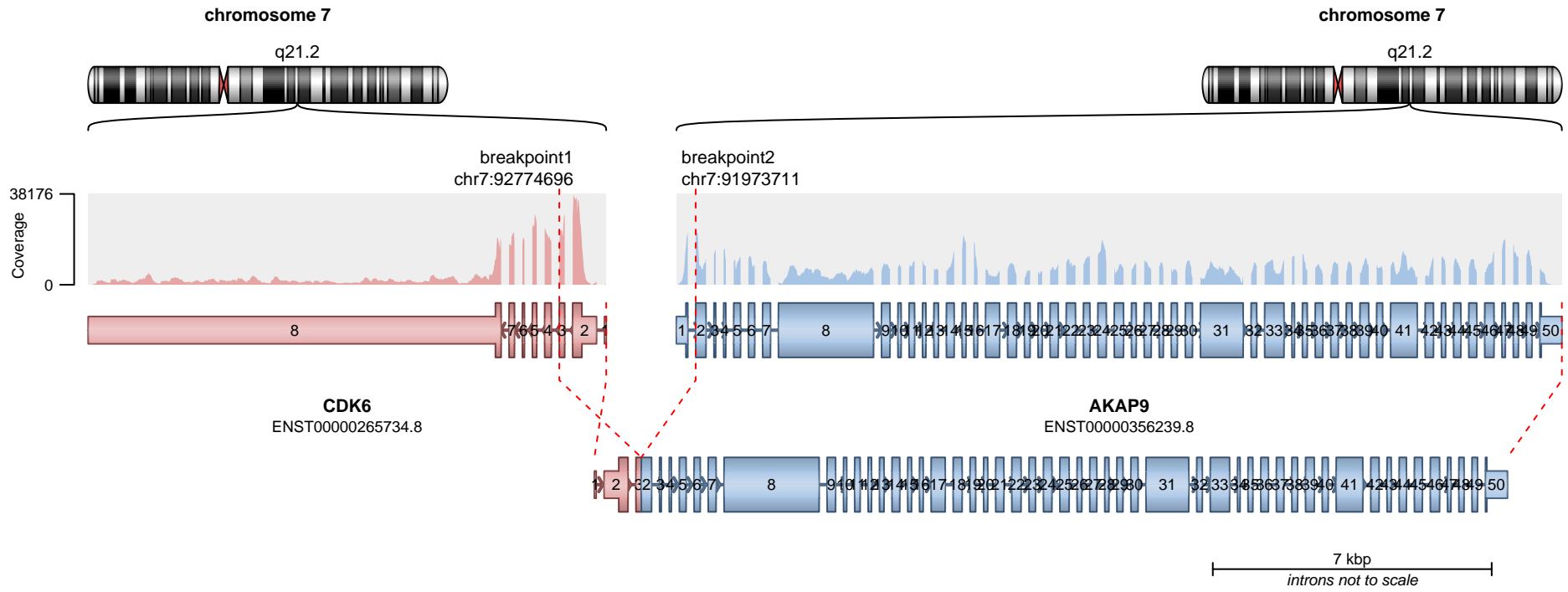

— translocation    — deletion  
— duplication    — inversion

**RETAINED PROTEIN DOMAINS**  
reading frame unclear

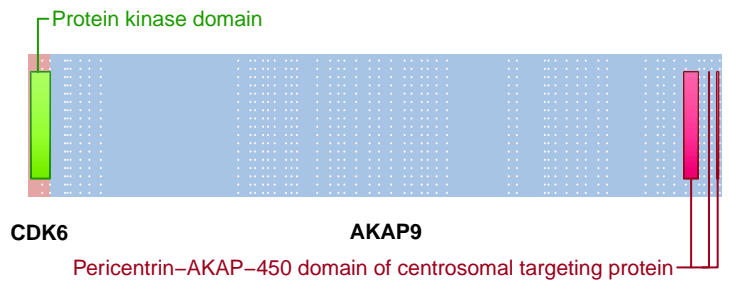

**SUPPORTING READ COUNT**

Split reads = 31  
Discordant mates = 3

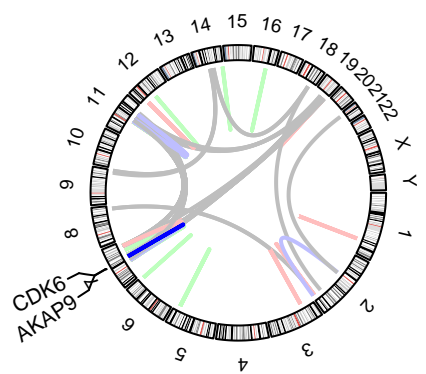
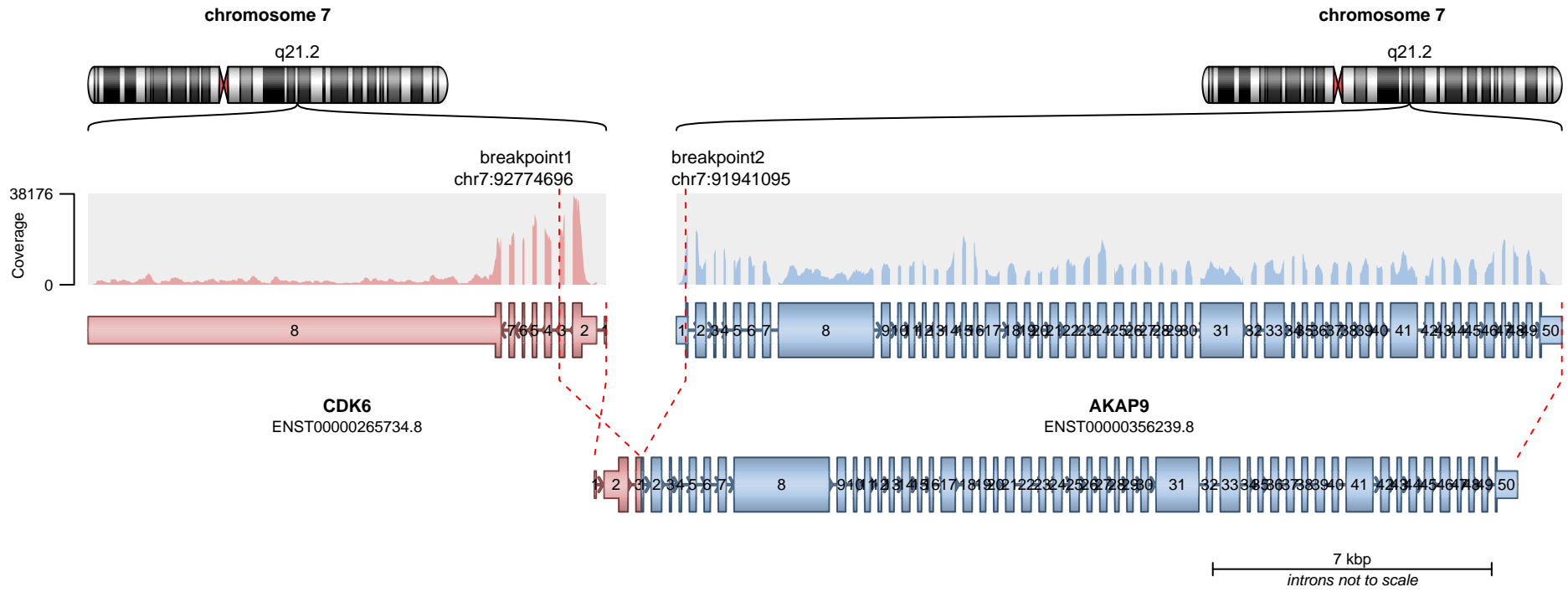

— translocation — deletion  
— duplication — inversion

**RETAINED PROTEIN DOMAINS**  
reading frame unclear

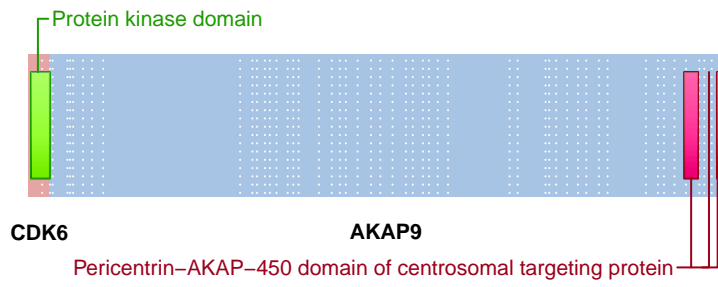

**SUPPORTING READ COUNT**

Split reads = 30  
Discordant mates = 4

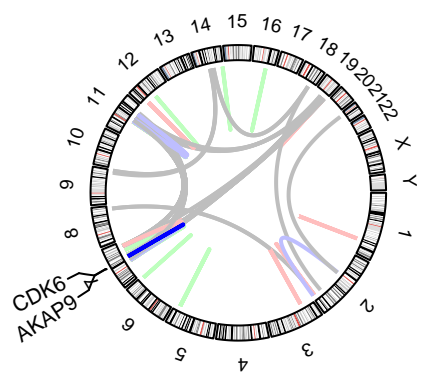
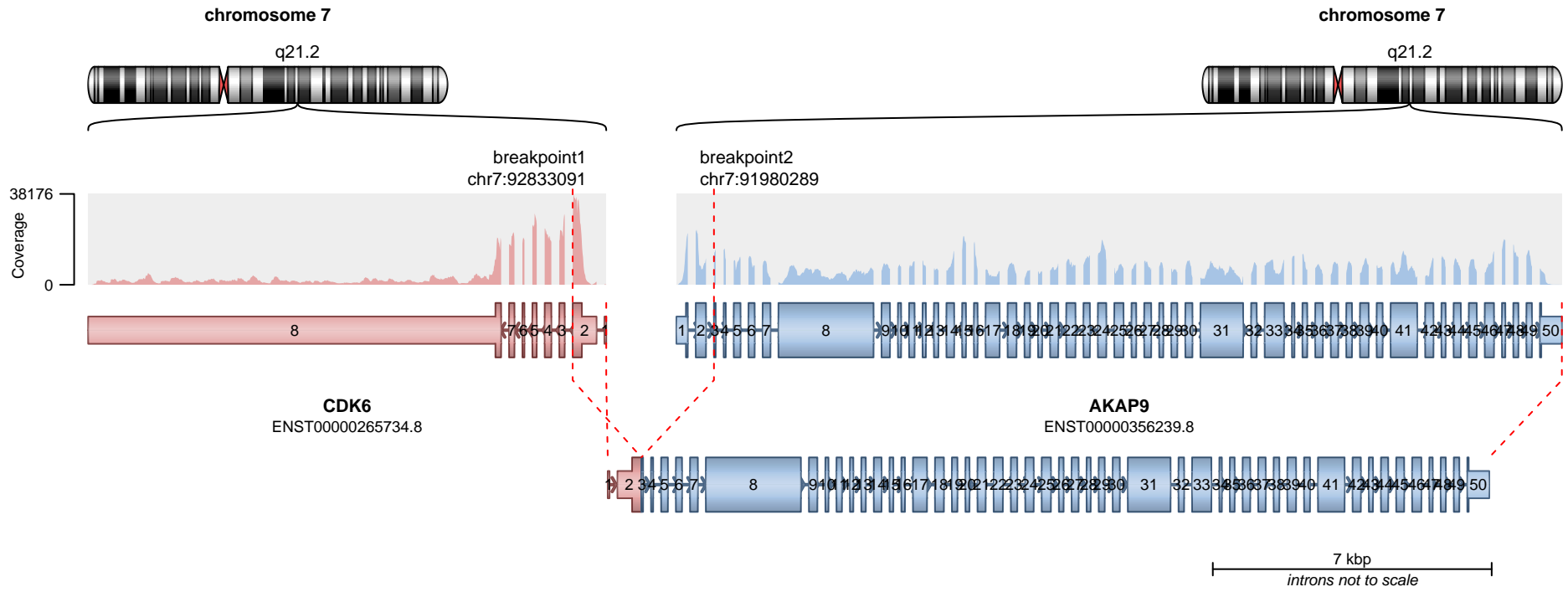

— translocation — deletion  
— duplication — inversion

**RETAINED PROTEIN DOMAINS**  
reading frame unclear

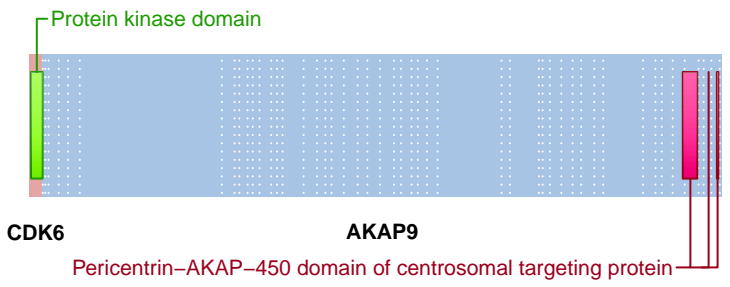

**SUPPORTING READ COUNT**

Split reads = 23  
Discordant mates = 0

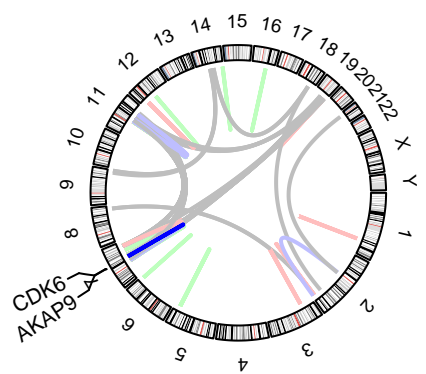
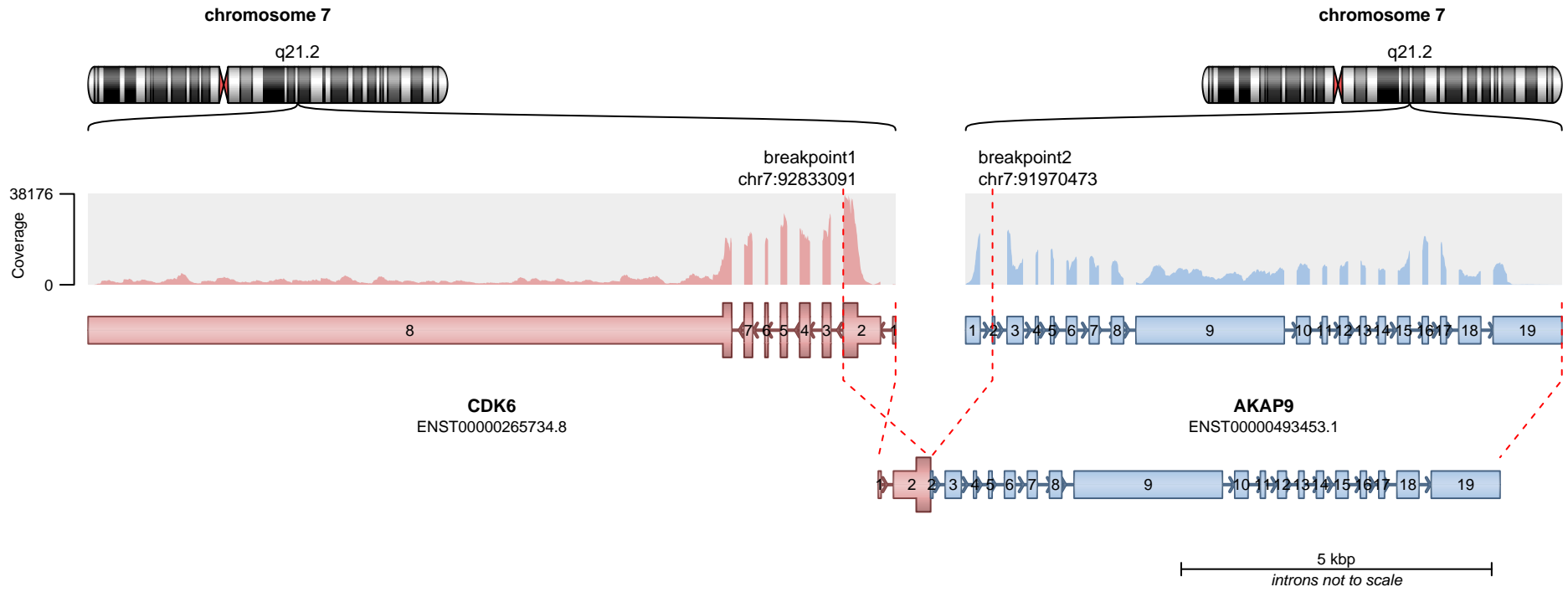

**RETAINED PROTEIN DOMAINS**  
reading frame unclear

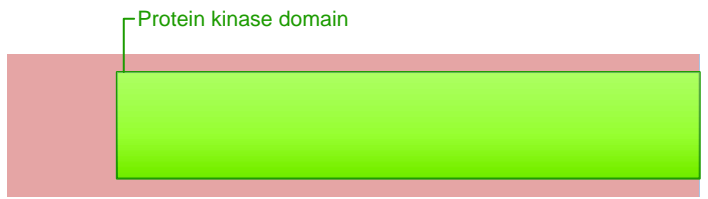

**SUPPORTING READ COUNT**

Split reads = 4  
Discordant mates = 4

- translocation
- duplication
- deletion
- inversion

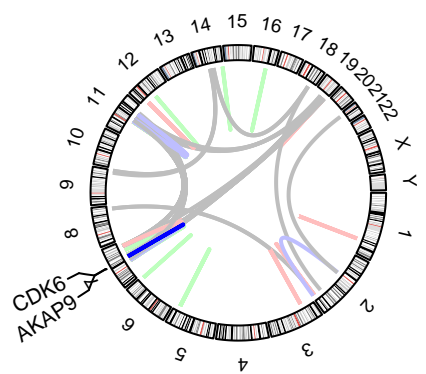
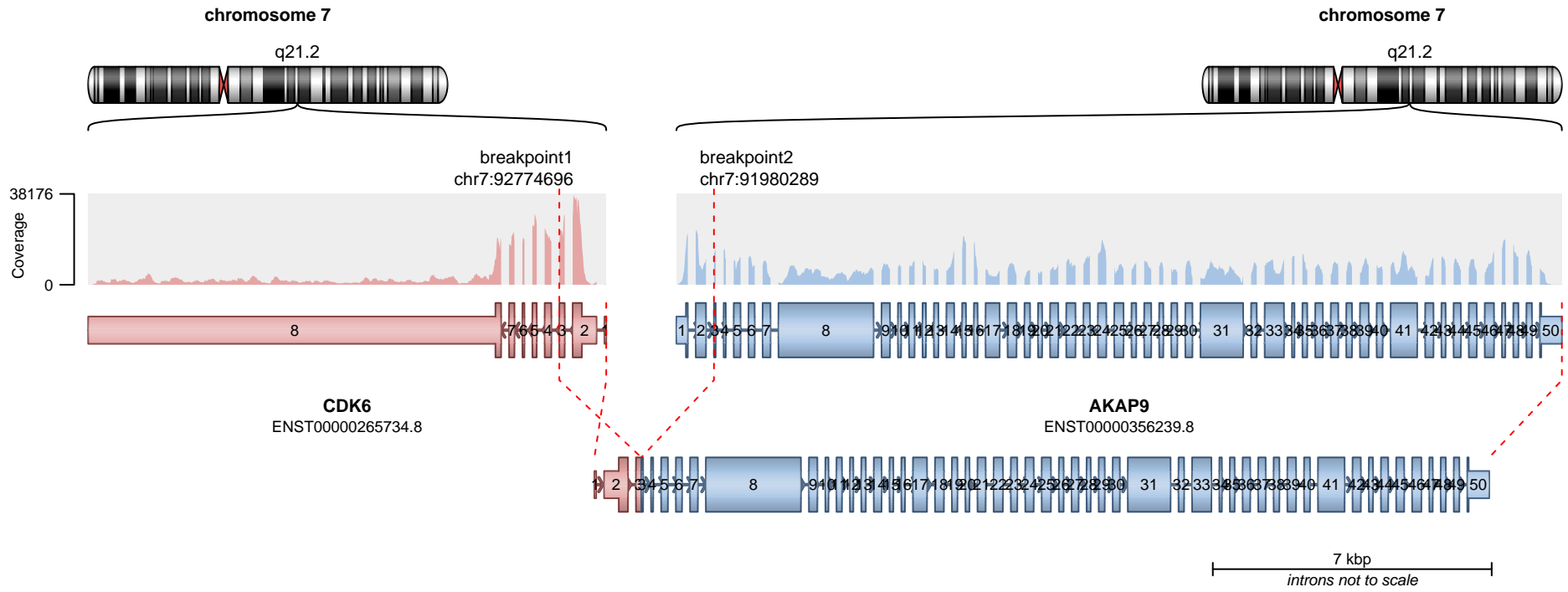

— translocation — deletion  
— duplication — inversion

**RETAINED PROTEIN DOMAINS**  
reading frame unclear

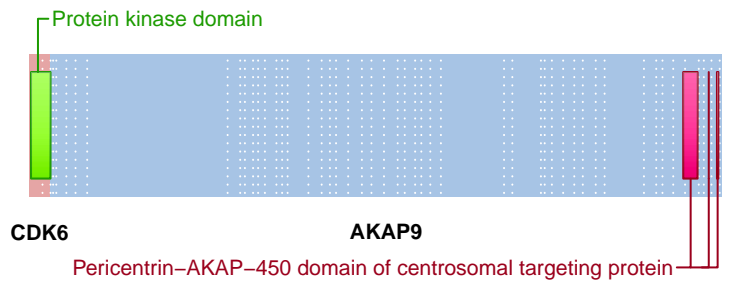

**SUPPORTING READ COUNT**

Split reads = 4  
Discordant mates = 0

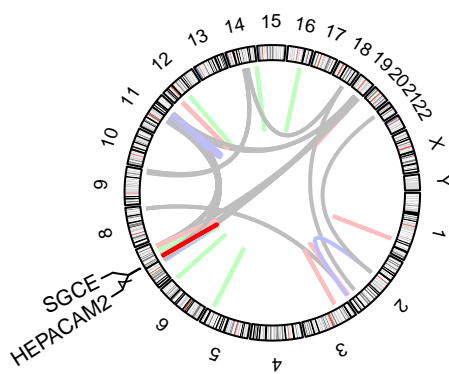
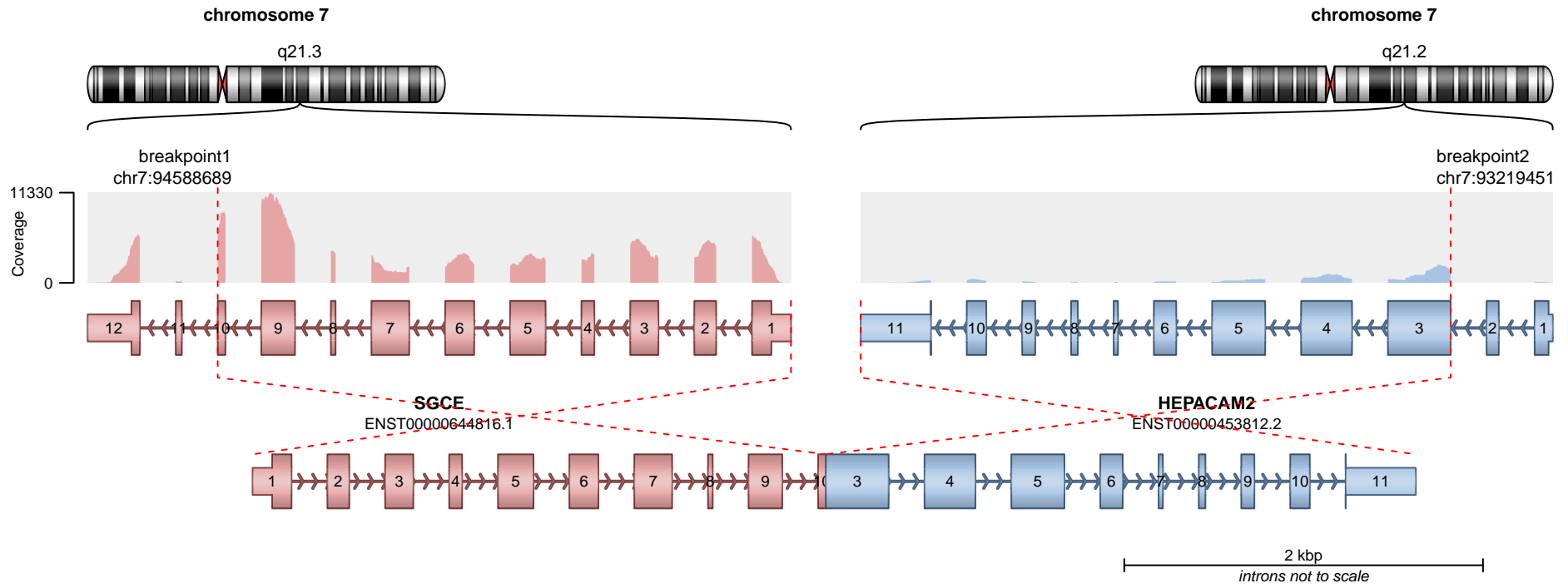

**RETAINED PROTEIN DOMAINS**  
reading frame unclear

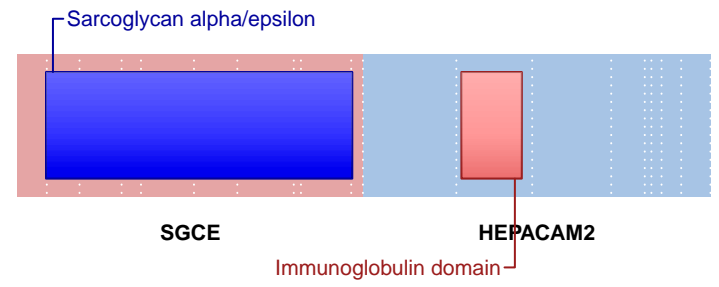

**SUPPORTING READ COUNT**

Split reads = 207  
Discordant mates = 0

- translocation
- duplication
- deletion
- inversion

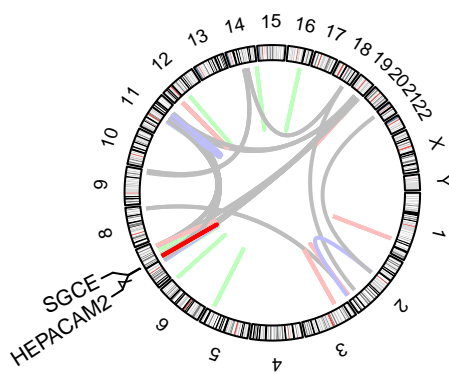
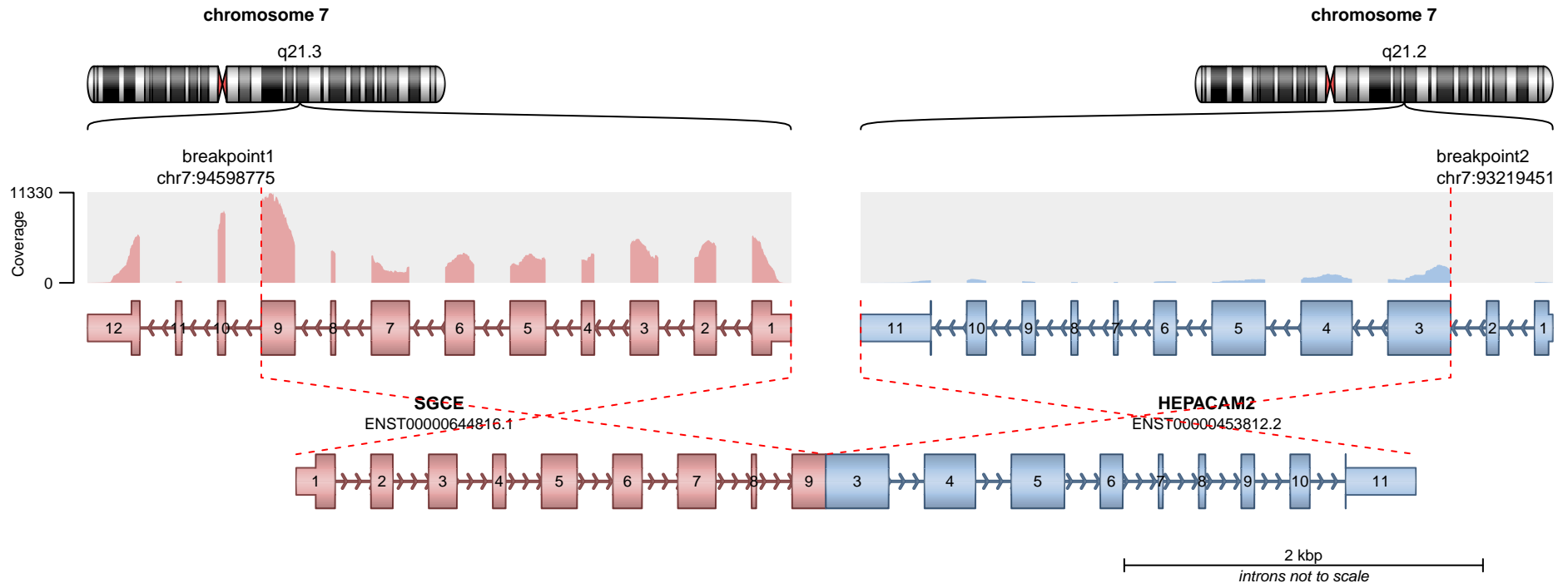

**RETAINED PROTEIN DOMAINS**  
reading frame unclear

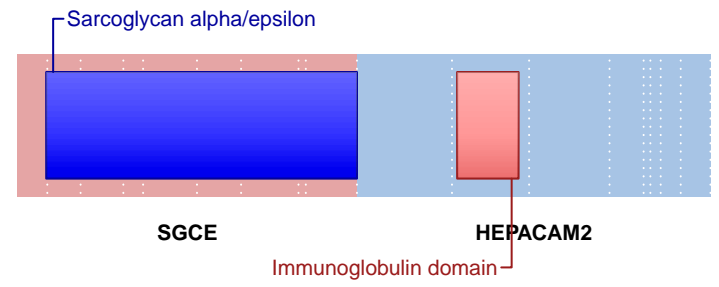

**SUPPORTING READ COUNT**

Split reads = 9  
Discordant mates = 0

- translocation
- duplication
- deletion
- inversion

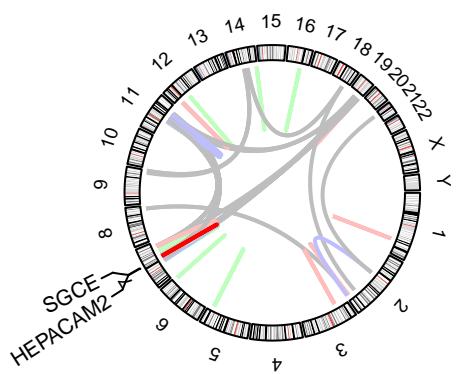
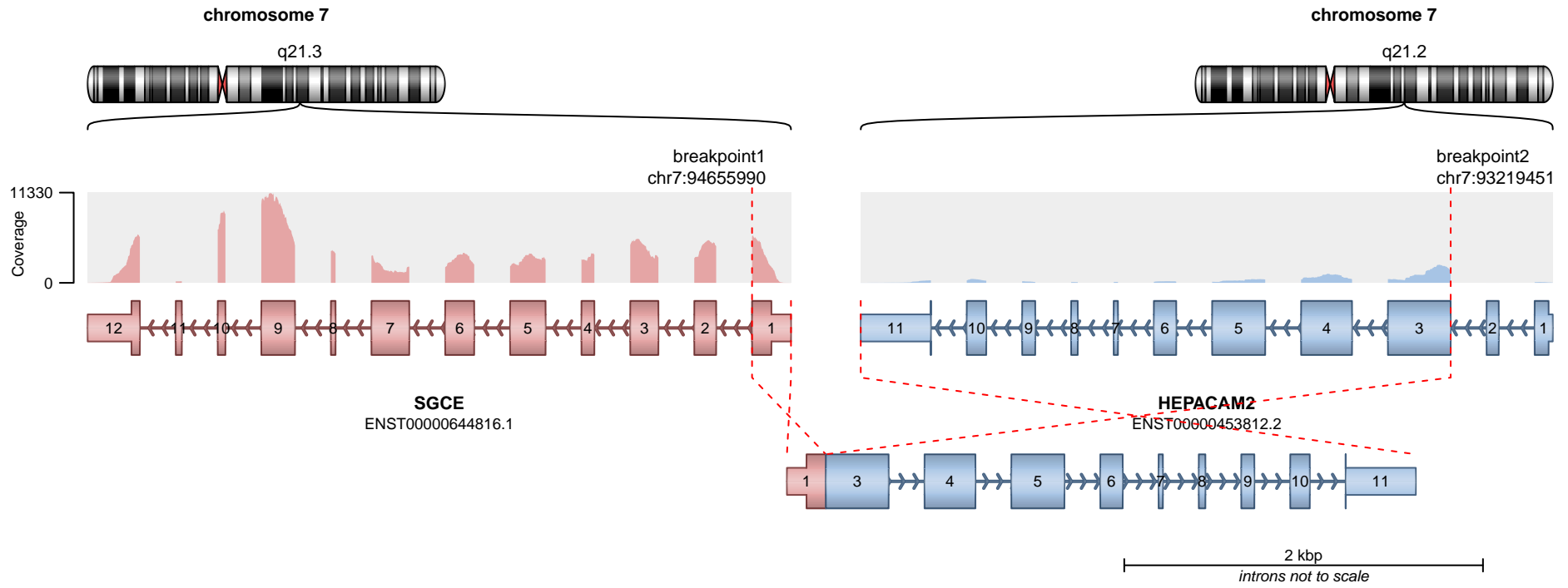

**RETAINED PROTEIN DOMAINS**  
reading frame unclear

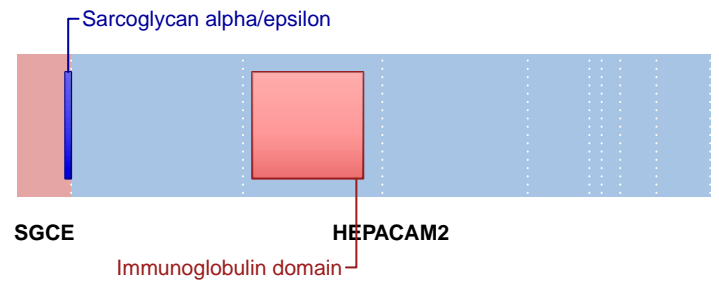

**SUPPORTING READ COUNT**

Split reads = 5  
Discordant mates = 0

- translocation
- duplication
- deletion
- inversion

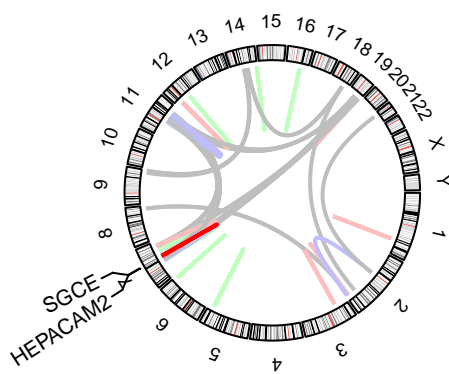
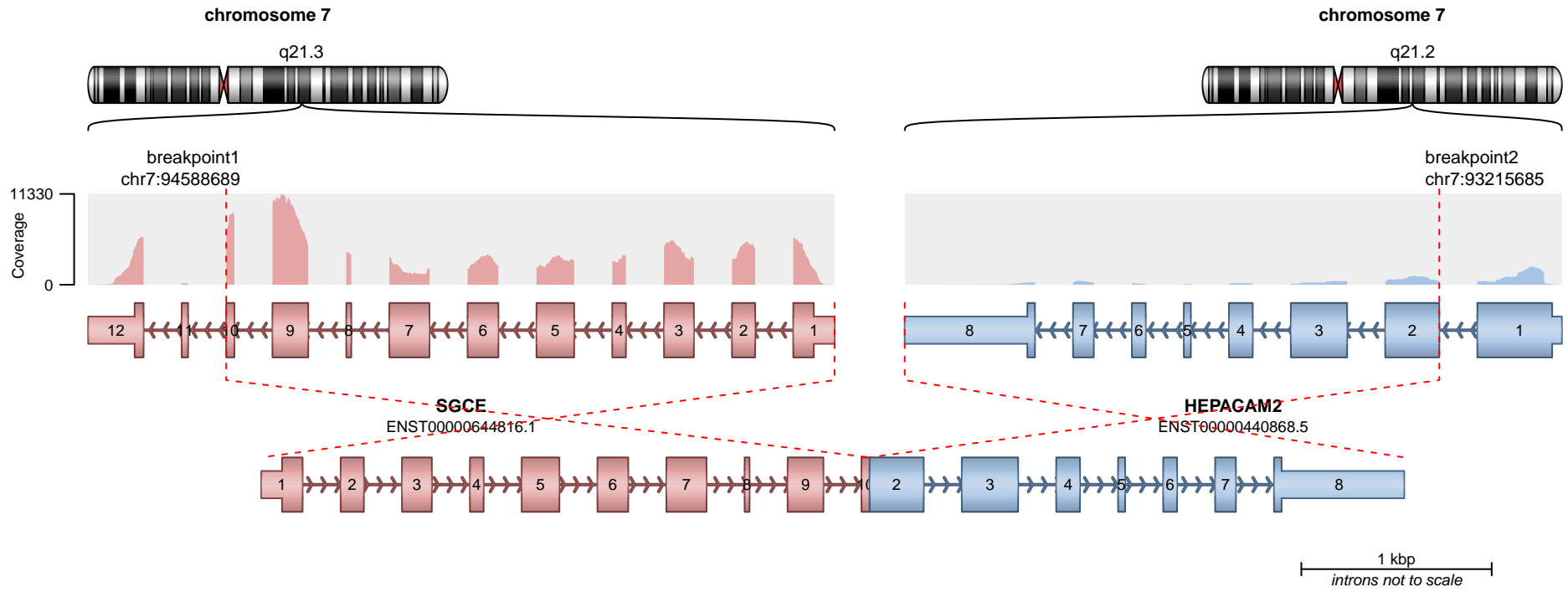

**RETAINED PROTEIN DOMAINS**  
reading frame unclear

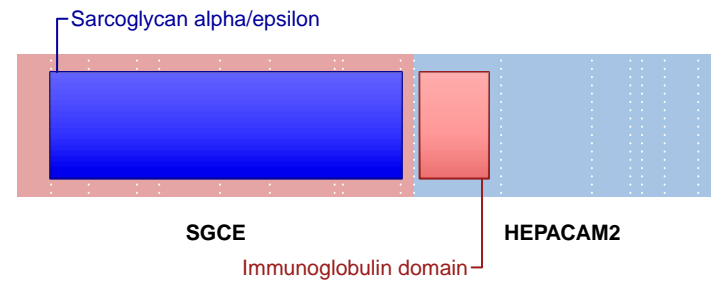

**SUPPORTING READ COUNT**

Split reads = 4  
Discordant mates = 0

- translocation
- duplication
- deletion
- inversion

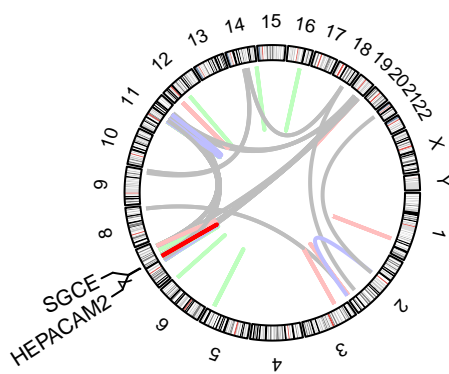
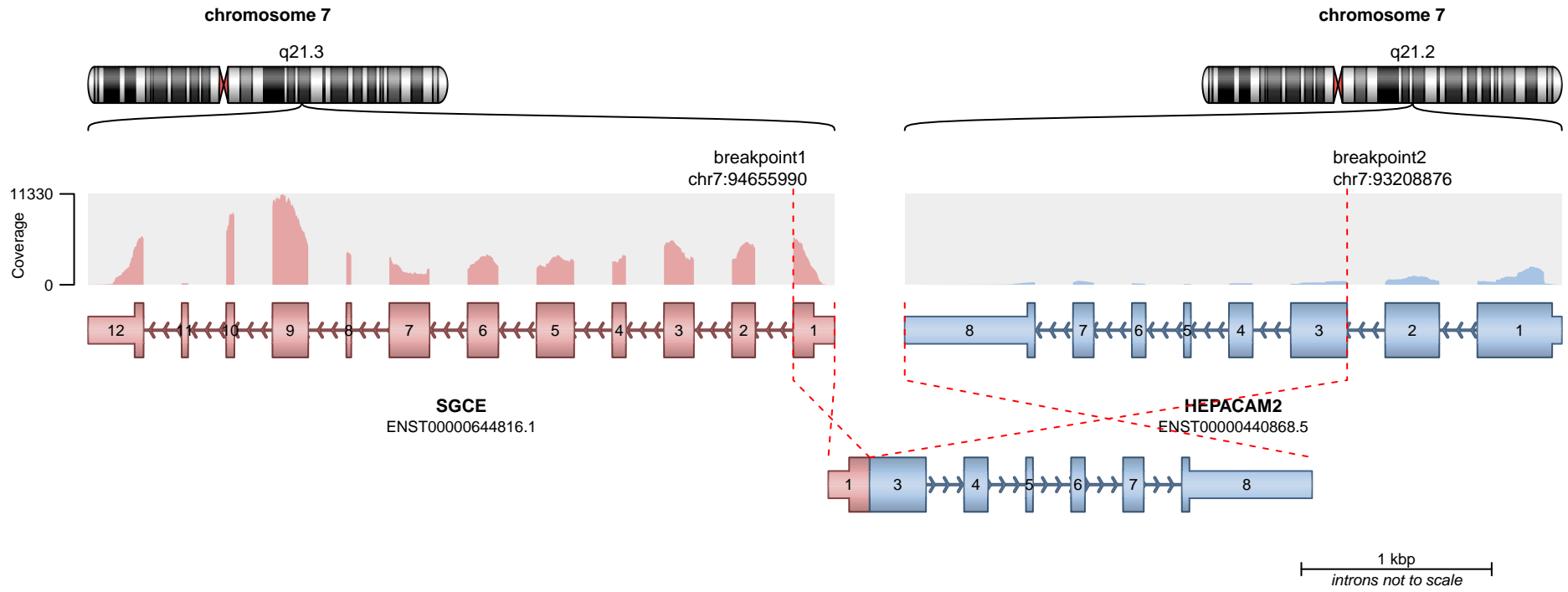

**RETAINED PROTEIN DOMAINS**  
reading frame unclear

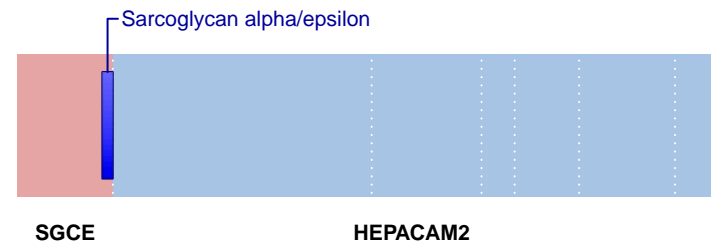

**SUPPORTING READ COUNT**

Split reads = 2  
Discordant mates = 0

- translocation
- duplication
- deletion
- inversion

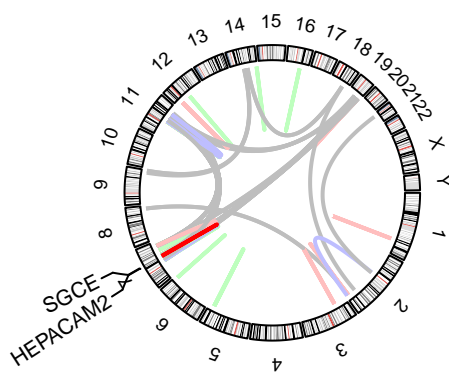
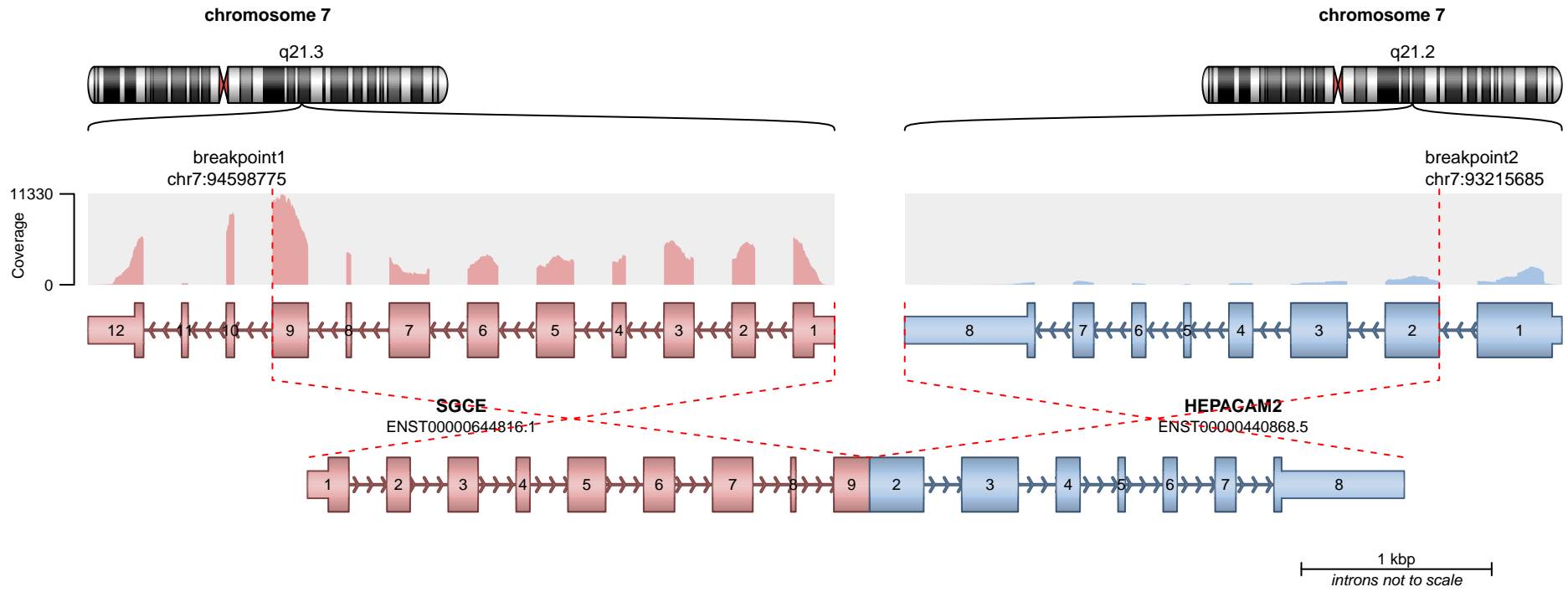

**RETAINED PROTEIN DOMAINS**  
reading frame unclear

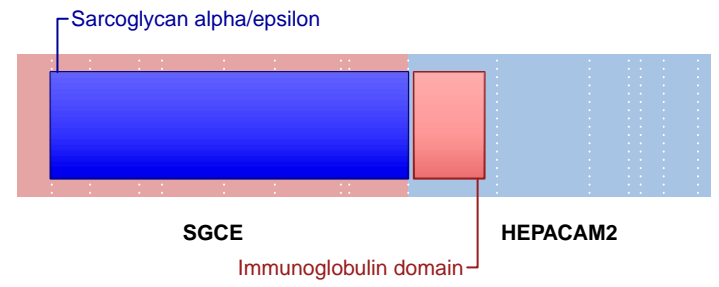

**SUPPORTING READ COUNT**

Split reads = 1  
Discordant mates = 0

- translocation
- duplication
- deletion
- inversion

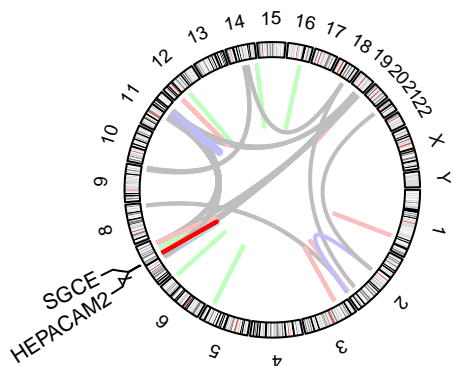
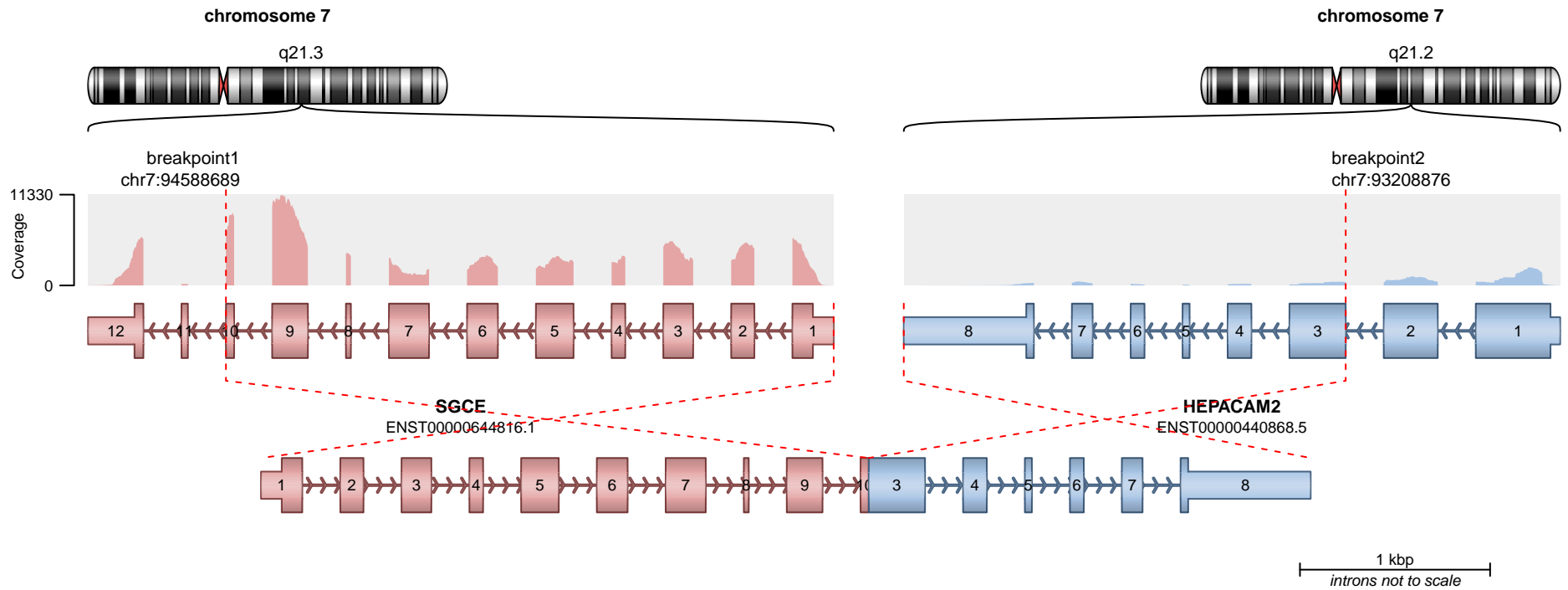

**RETAINED PROTEIN DOMAINS**  
reading frame unclear

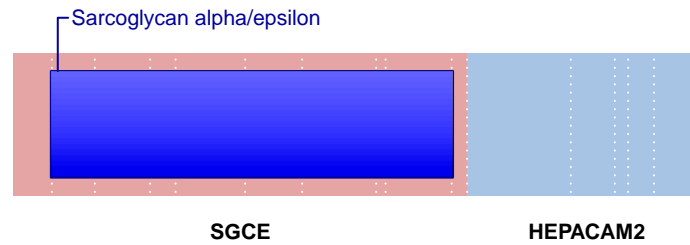

**SUPPORTING READ COUNT**

Split reads = 1  
Discordant mates = 0

— translocation — deletion  
— duplication — inversion

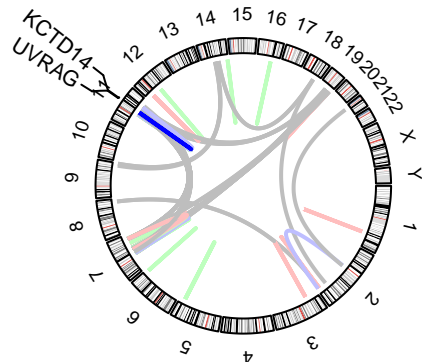
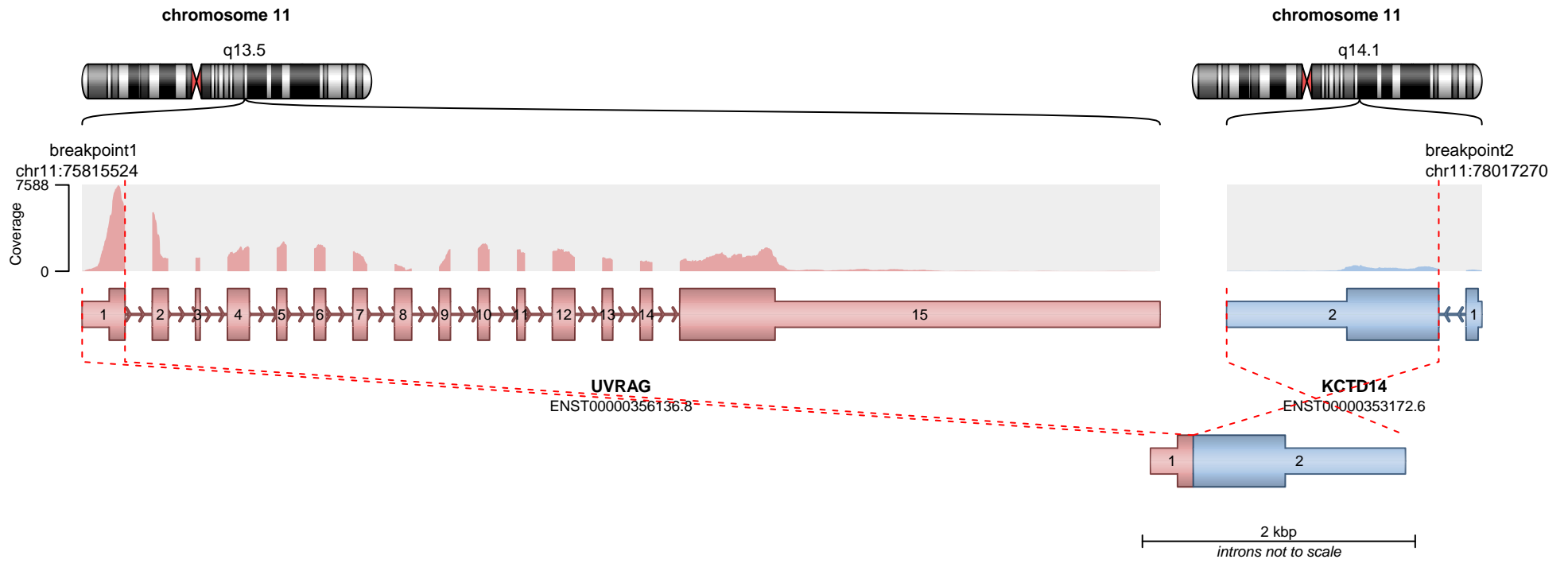

NADH-ubiquinone oxidoreductase subunit b14.5b (NDUFC2)

**RETAINED PROTEIN DOMAINS**  
reading frame unclear

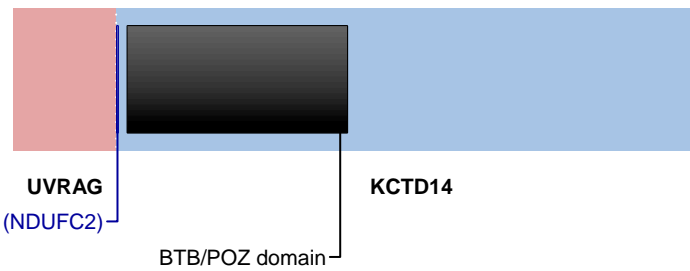

**SUPPORTING READ COUNT**

Split reads = 190  
Discordant mates = 1

— translocation    — deletion  
— duplication    — inversion

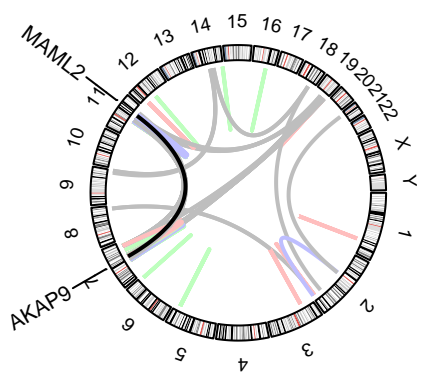
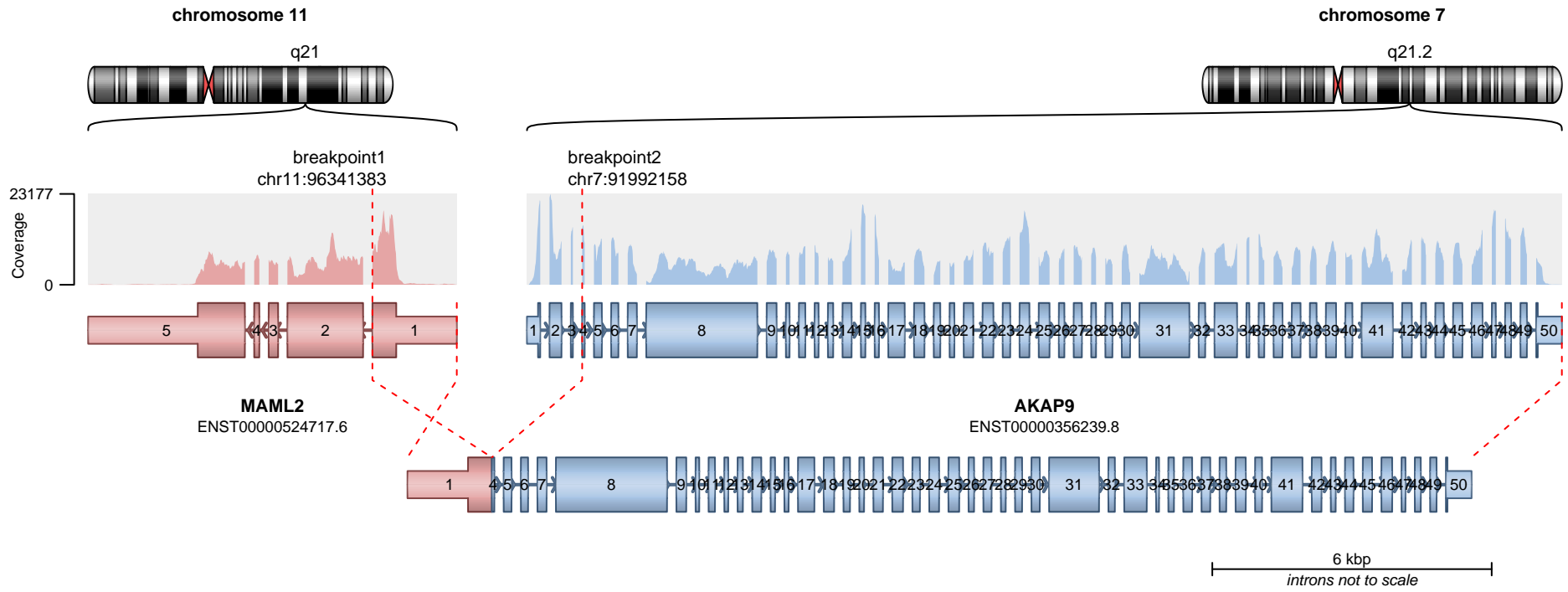

— translocation — deletion  
— duplication — inversion

**RETAINED PROTEIN DOMAINS**  
reading frame unclear

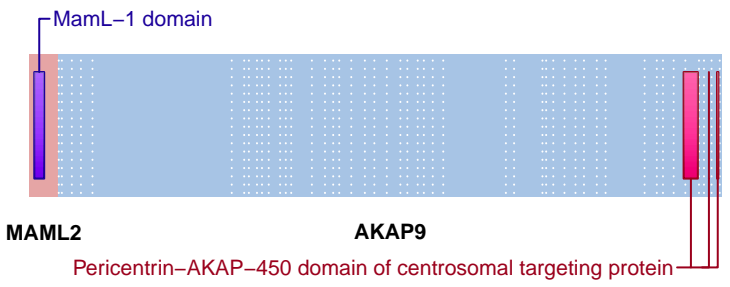

**SUPPORTING READ COUNT**

Split reads = 147  
Discordant mates = 0

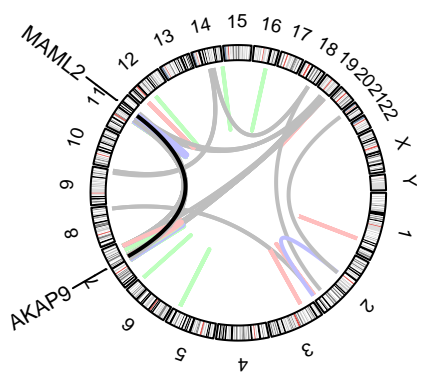
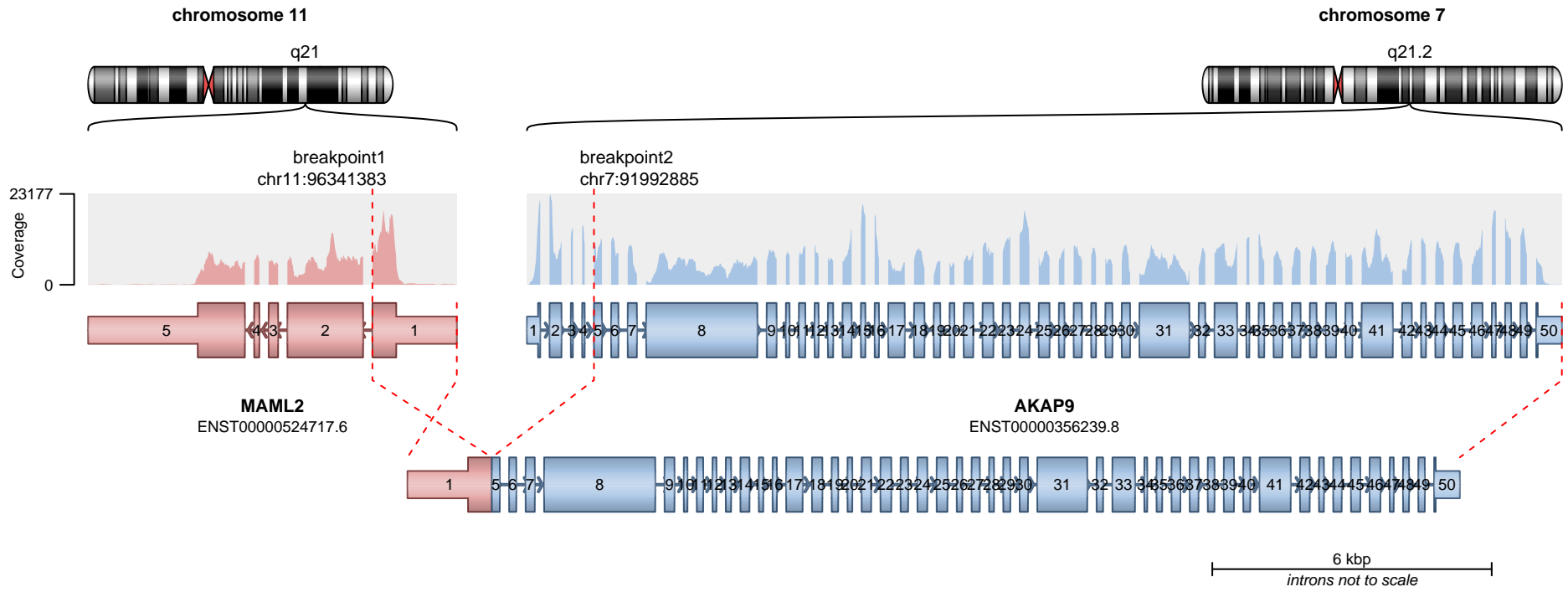

**RETAINED PROTEIN DOMAINS**  
reading frame unclear

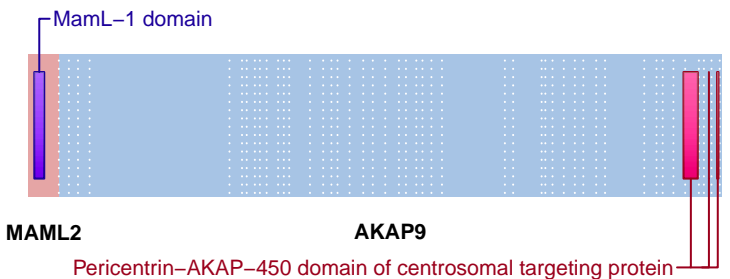

**SUPPORTING READ COUNT**

Split reads = 79  
Discordant mates = 0

- translocation
- duplication
- deletion
- inversion

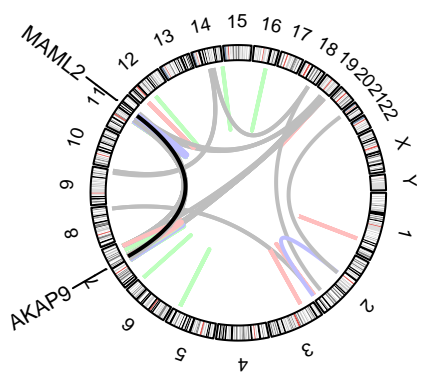
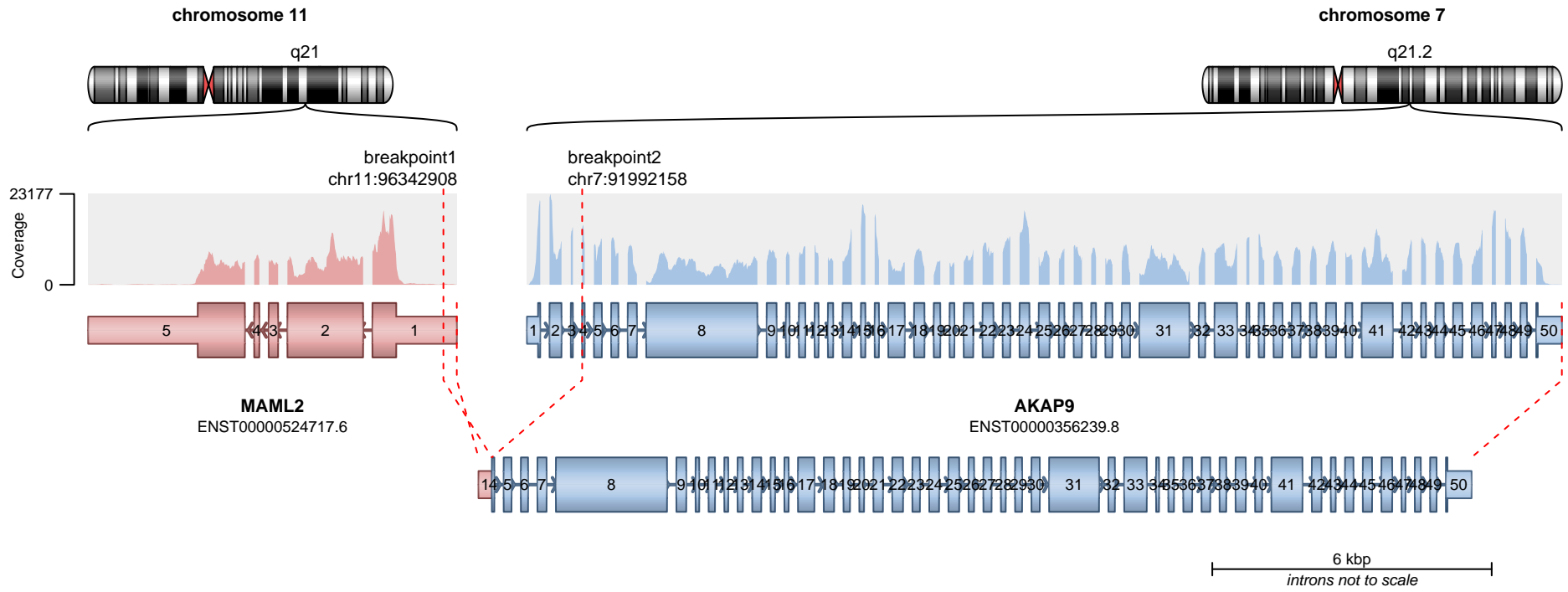

— translocation — deletion  
— duplication — inversion

**RETAINED PROTEIN DOMAINS**  
reading frame unclear

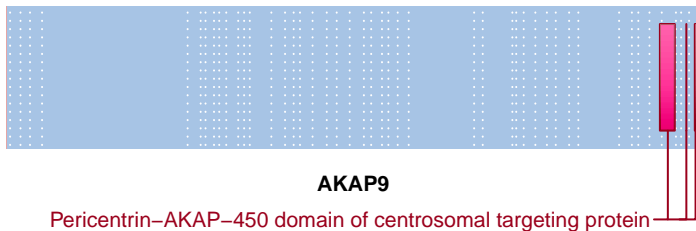

**SUPPORTING READ COUNT**

Split reads = 6  
Discordant mates = 0

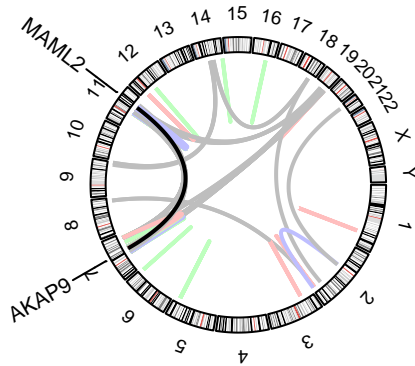
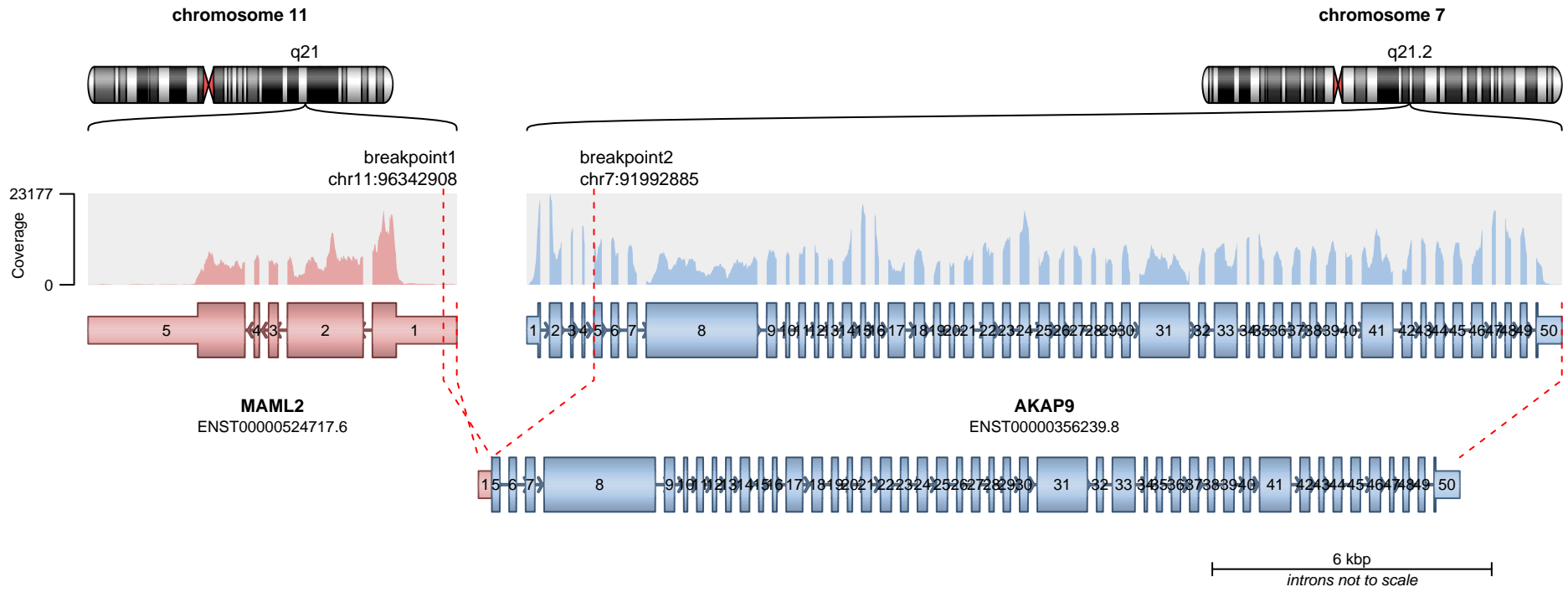

— translocation — deletion  
— duplication — inversion

**RETAINED PROTEIN DOMAINS**  
reading frame unclear

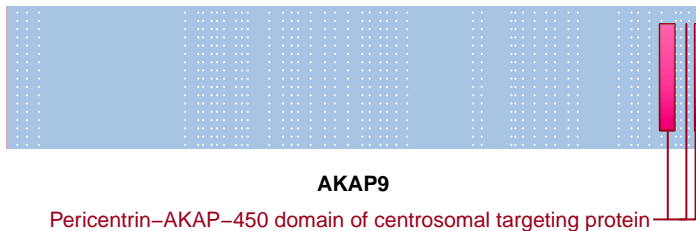

**SUPPORTING READ COUNT**

Split reads = 3  
Discordant mates = 0

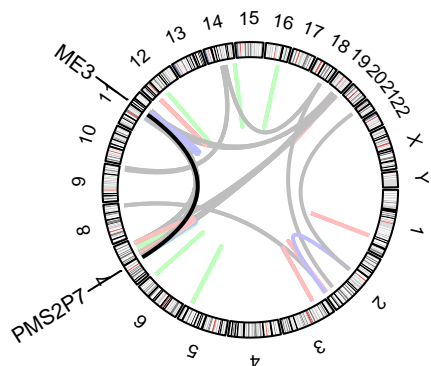
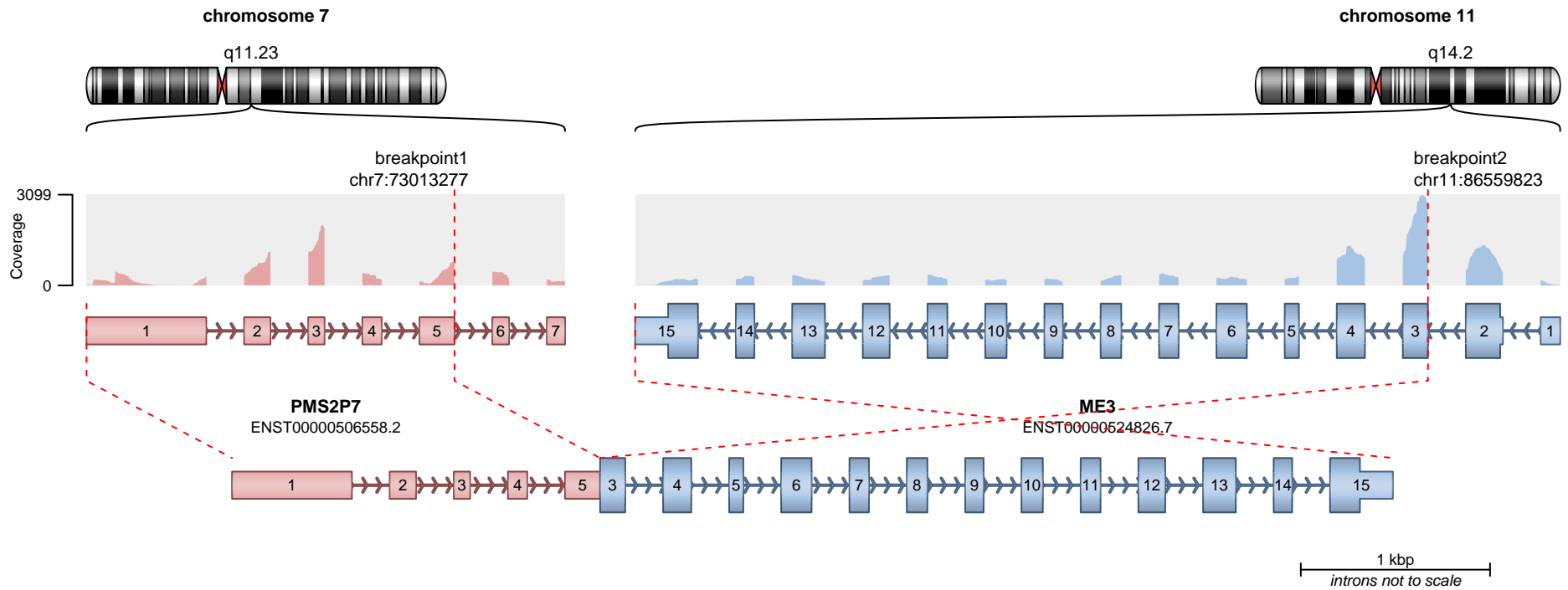

**RETAINED PROTEIN DOMAINS**  
reading frame unclear

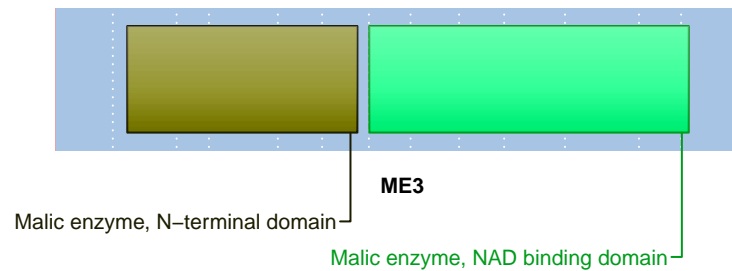

**SUPPORTING READ COUNT**

Split reads = 142  
Discordant mates = 0

- translocation
- duplication
- deletion
- inversion

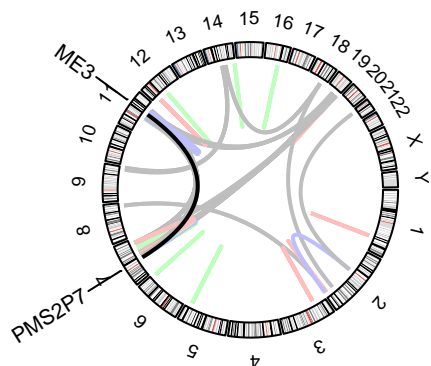
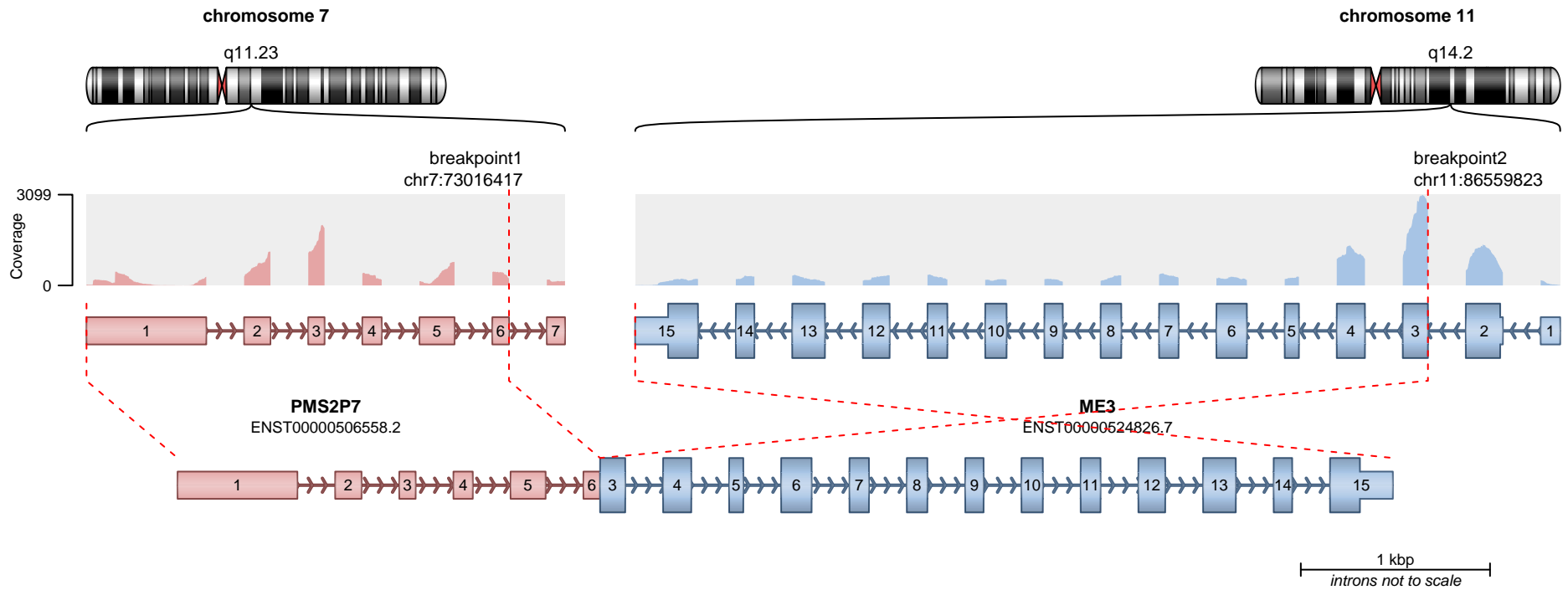

**RETAINED PROTEIN DOMAINS**  
reading frame unclear

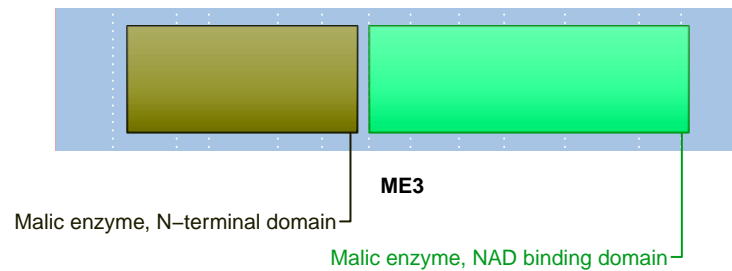

**SUPPORTING READ COUNT**

Split reads = 78  
Discordant mates = 1

- translocation
- duplication
- deletion
- inversion

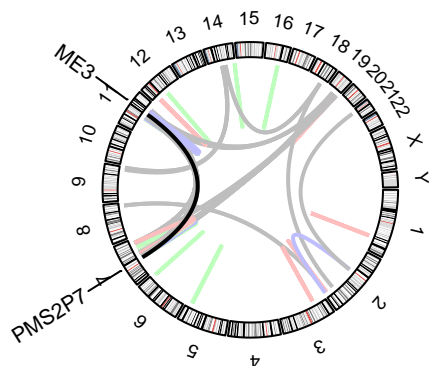
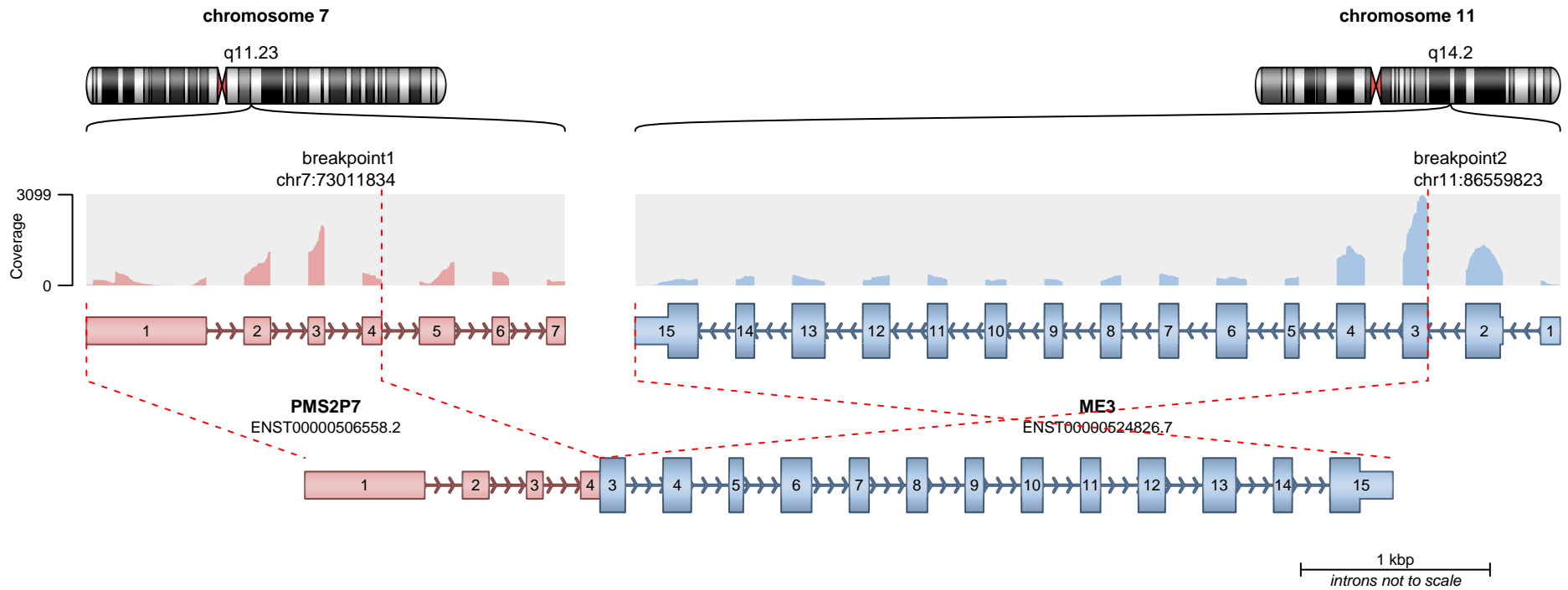

**RETAINED PROTEIN DOMAINS**  
reading frame unclear

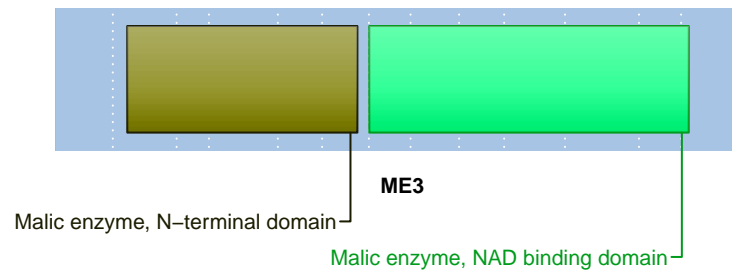

**SUPPORTING READ COUNT**

Split reads = 1  
Discordant mates = 0

— translocation — deletion  
— duplication — inversion

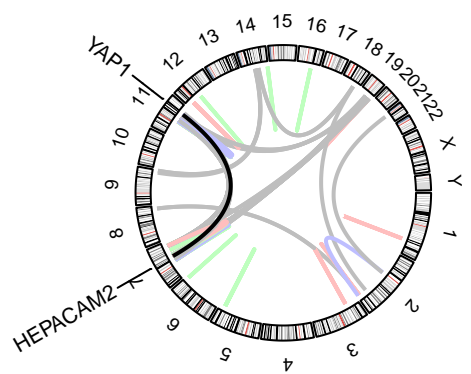
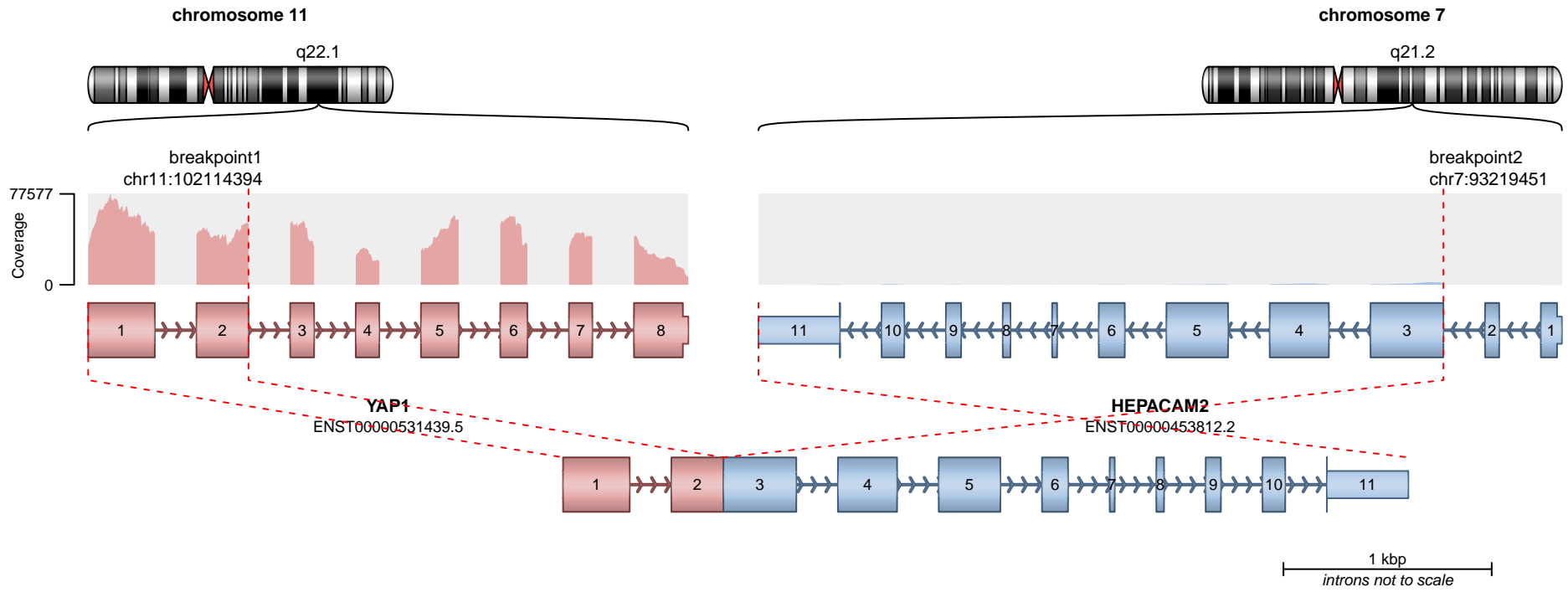

**RETAINED PROTEIN DOMAINS**  
reading frame unclear

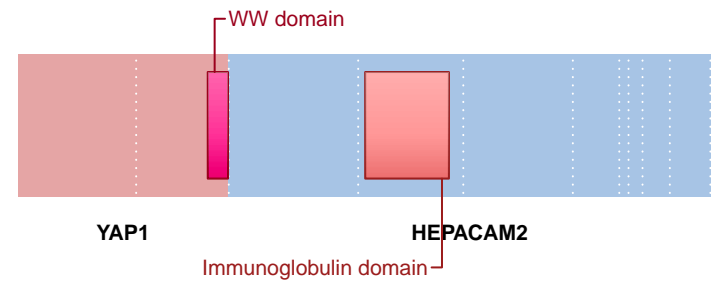

**SUPPORTING READ COUNT**

Split reads = 106  
Discordant mates = 2

- translocation
- duplication
- deletion
- inversion

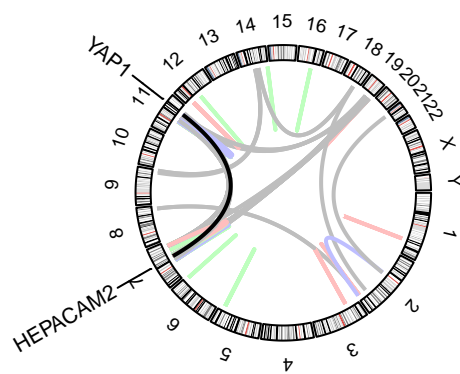
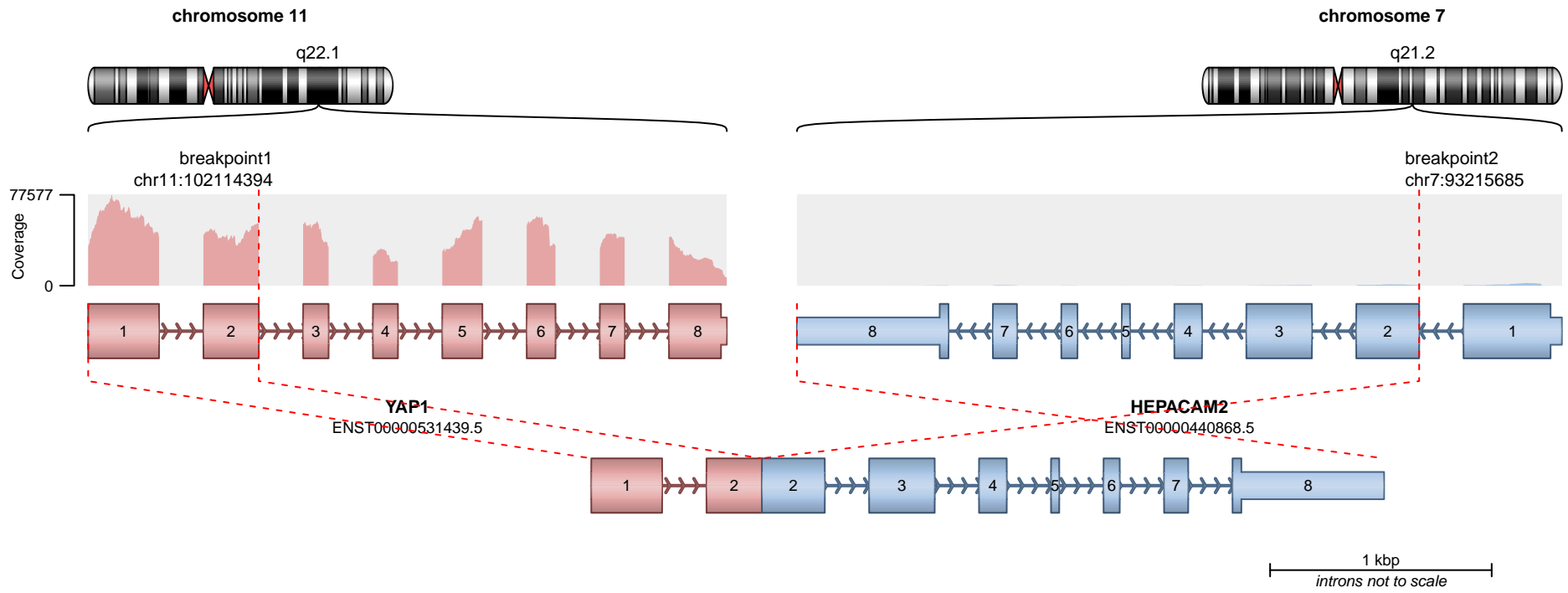

**RETAINED PROTEIN DOMAINS**  
reading frame unclear

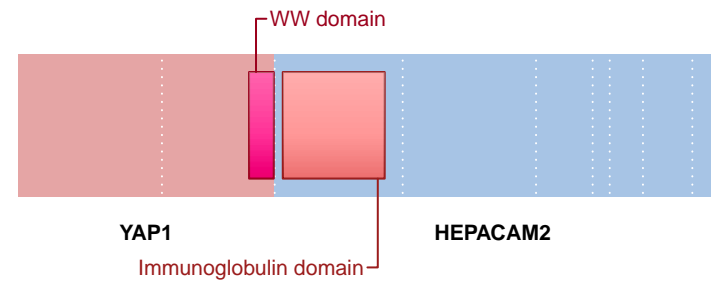

**SUPPORTING READ COUNT**

Split reads = 2  
Discordant mates = 0

— translocation — deletion  
— duplication — inversion

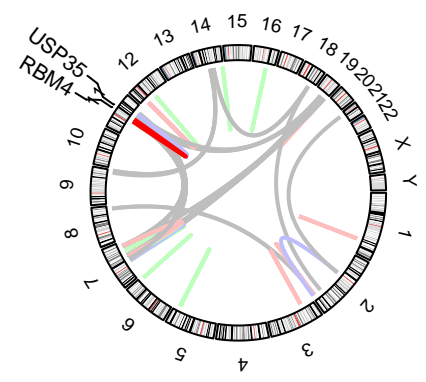
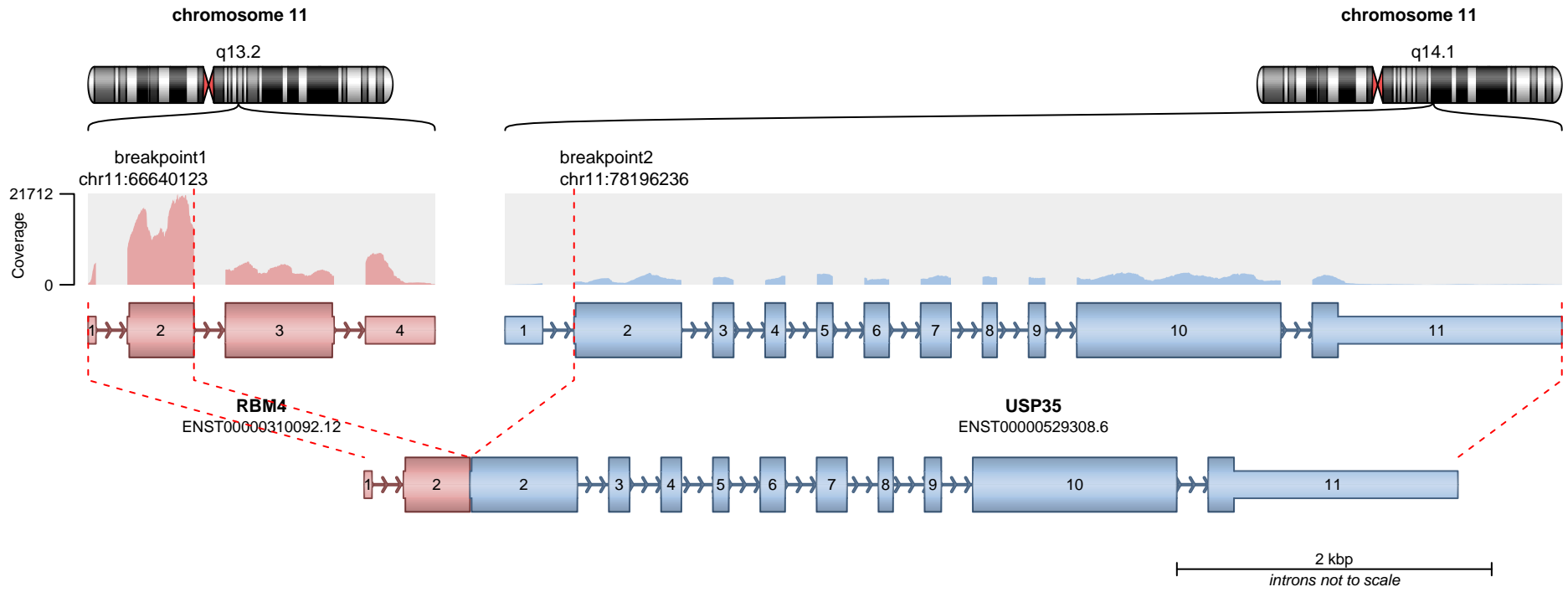

**RETAINED PROTEIN DOMAINS**  
reading frame unclear

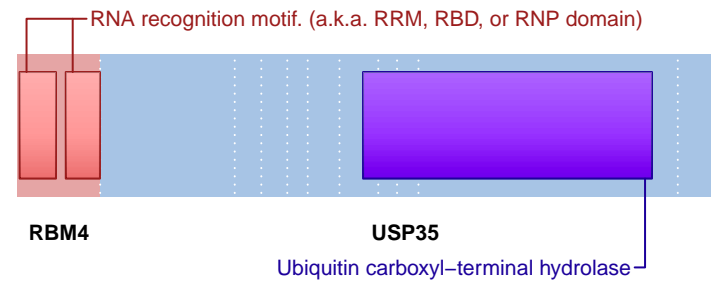

**SUPPORTING READ COUNT**

Split reads = 83  
Discordant mates = 0

- translocation
- duplication
- deletion
- inversion

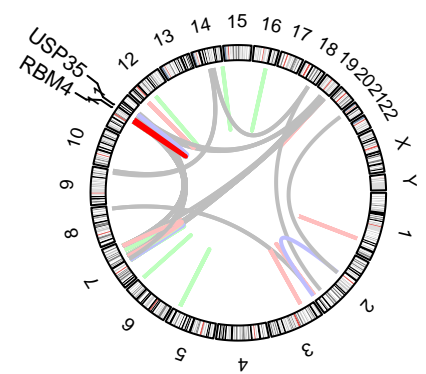
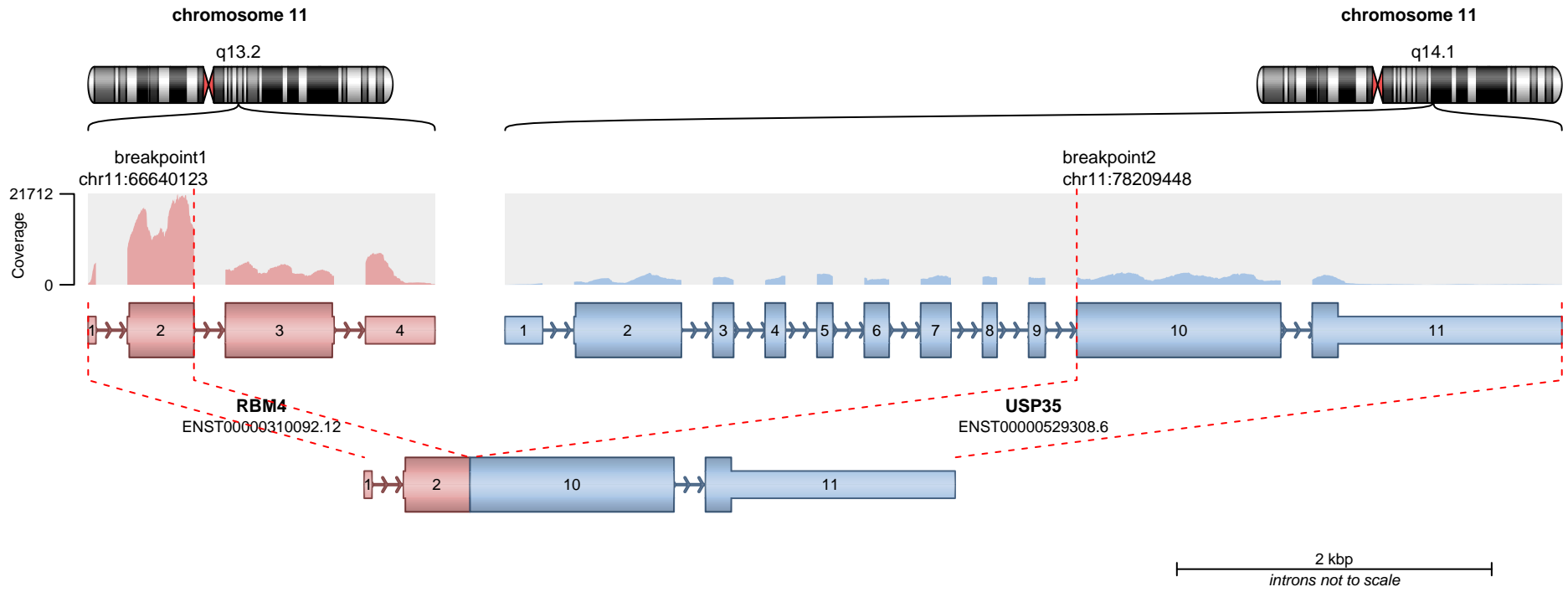

**RETAINED PROTEIN DOMAINS**  
reading frame unclear

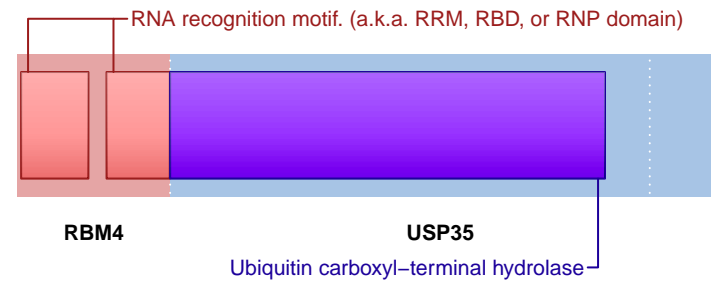

**SUPPORTING READ COUNT**

Split reads = 13  
Discordant mates = 0

- translocation
- duplication
- deletion
- inversion

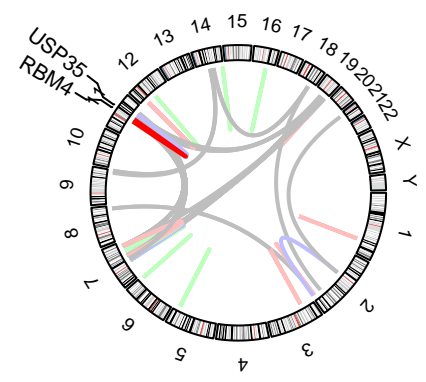
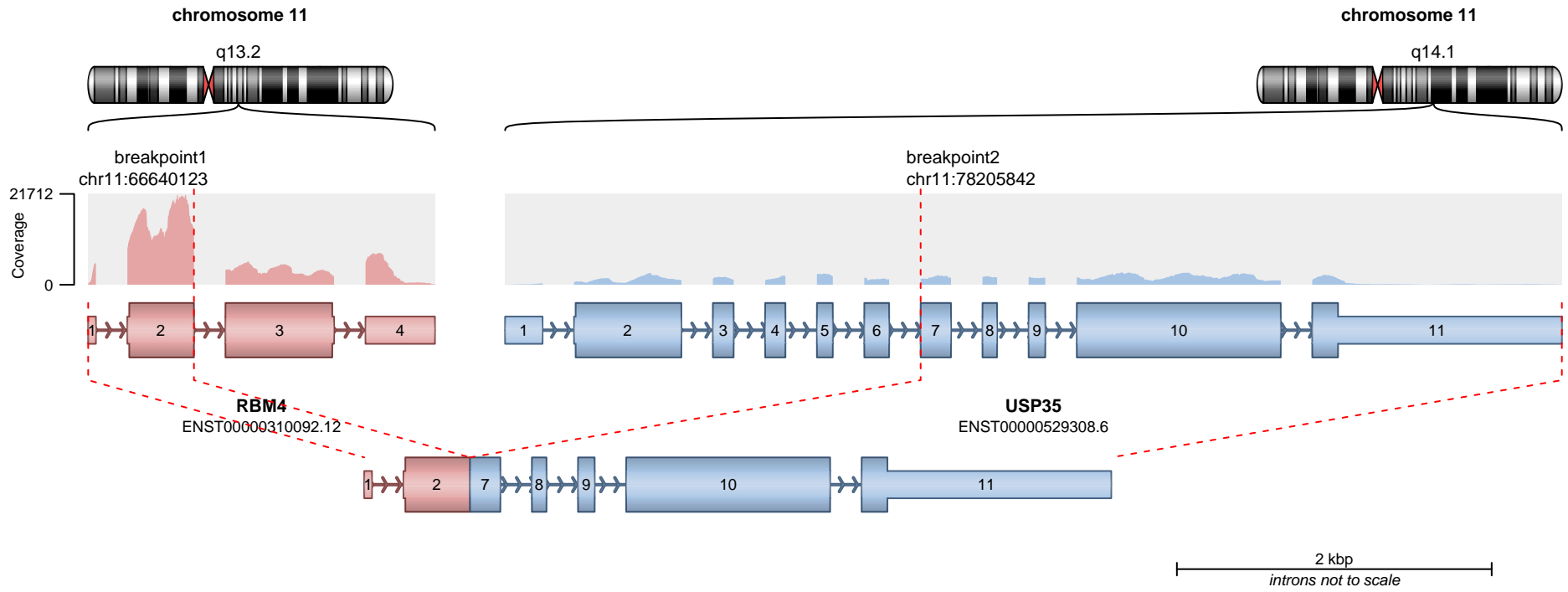

**RETAINED PROTEIN DOMAINS**  
reading frame unclear

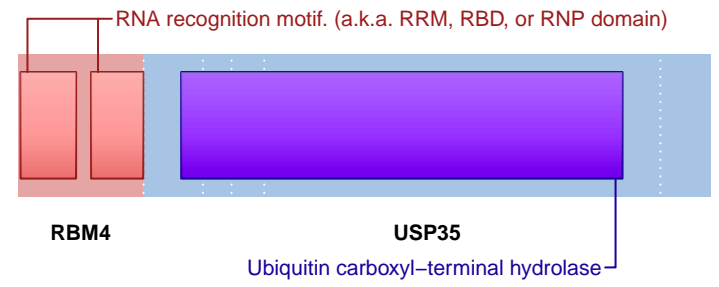

**SUPPORTING READ COUNT**

Split reads = 12  
Discordant mates = 0

- translocation
- duplication
- deletion
- inversion

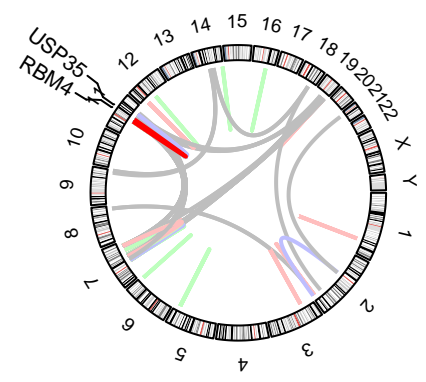
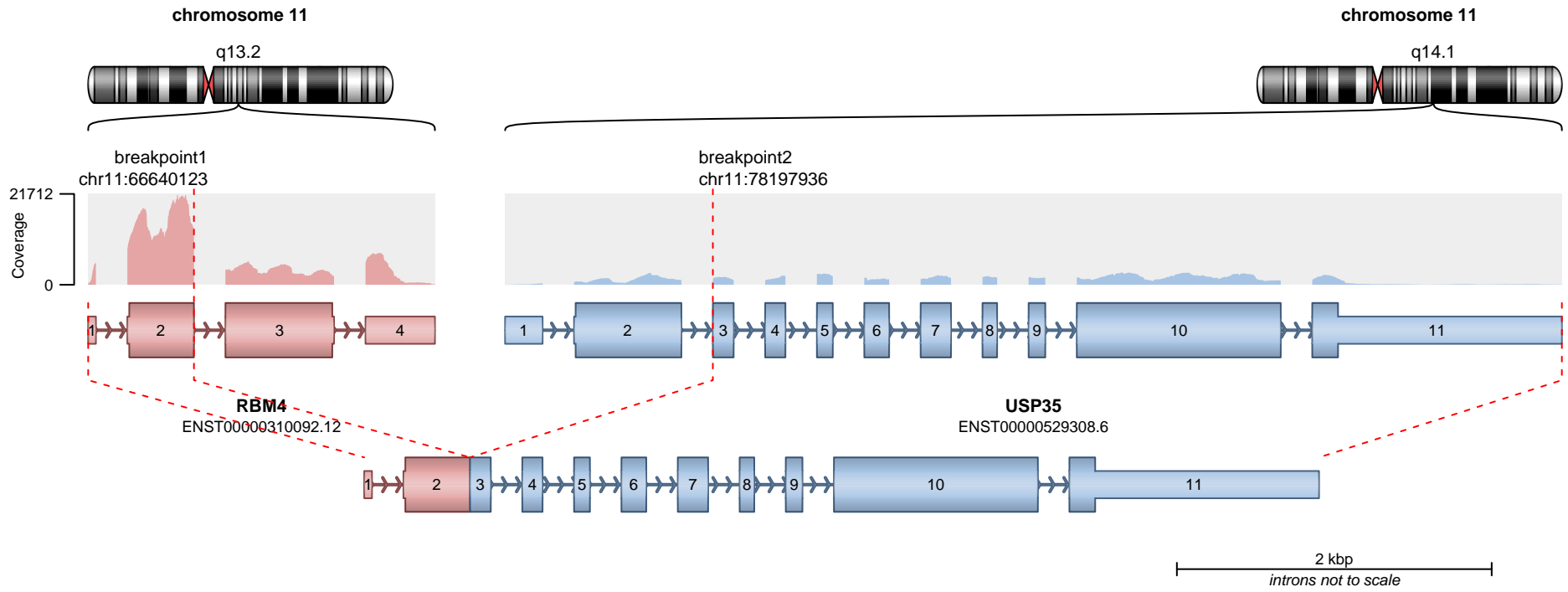

**RETAINED PROTEIN DOMAINS**  
reading frame unclear

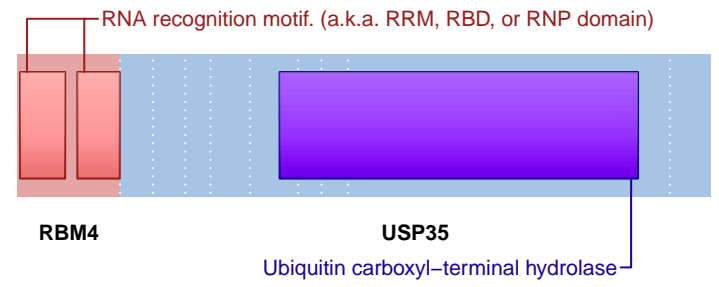

**SUPPORTING READ COUNT**

Split reads = 11  
Discordant mates = 0

- translocation
- duplication
- deletion
- inversion

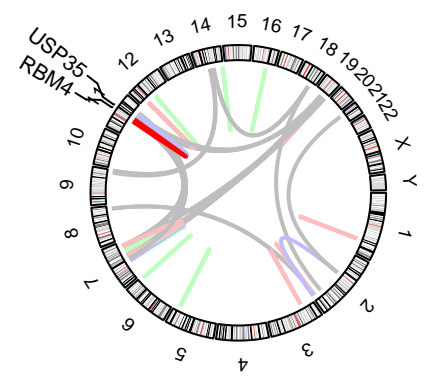
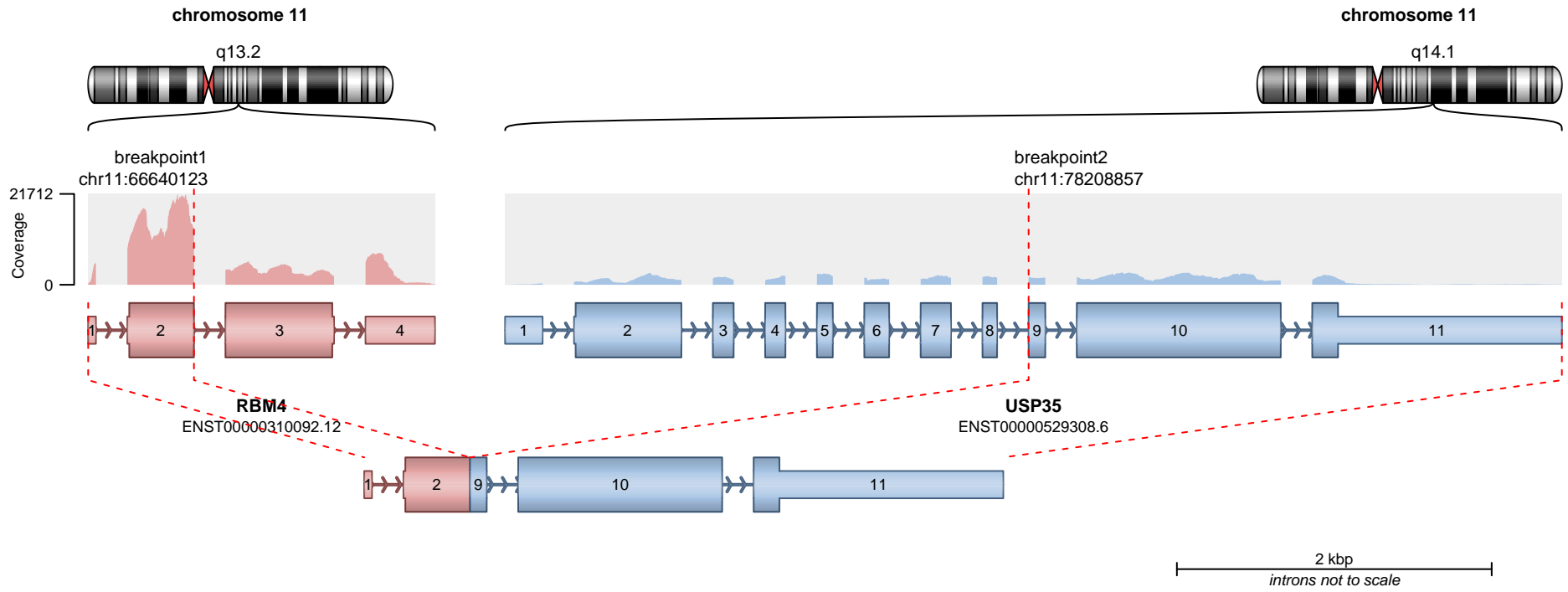

**RETAINED PROTEIN DOMAINS**  
reading frame unclear

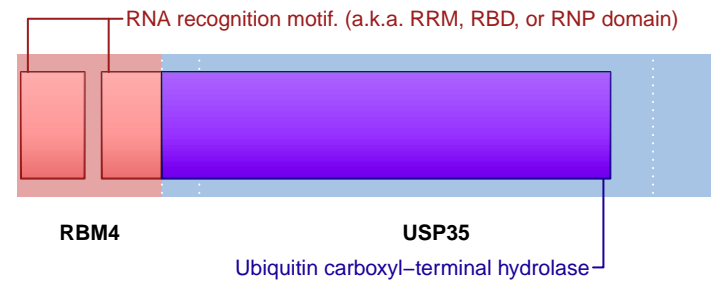

**SUPPORTING READ COUNT**

Split reads = 7  
Discordant mates = 0

- translocation
- duplication
- deletion
- inversion

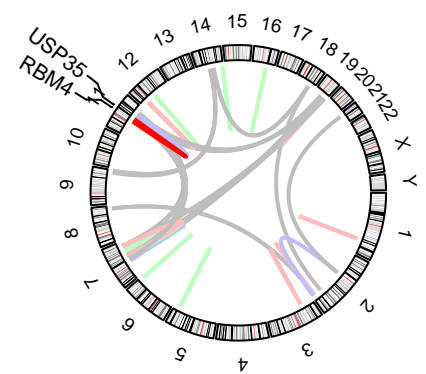
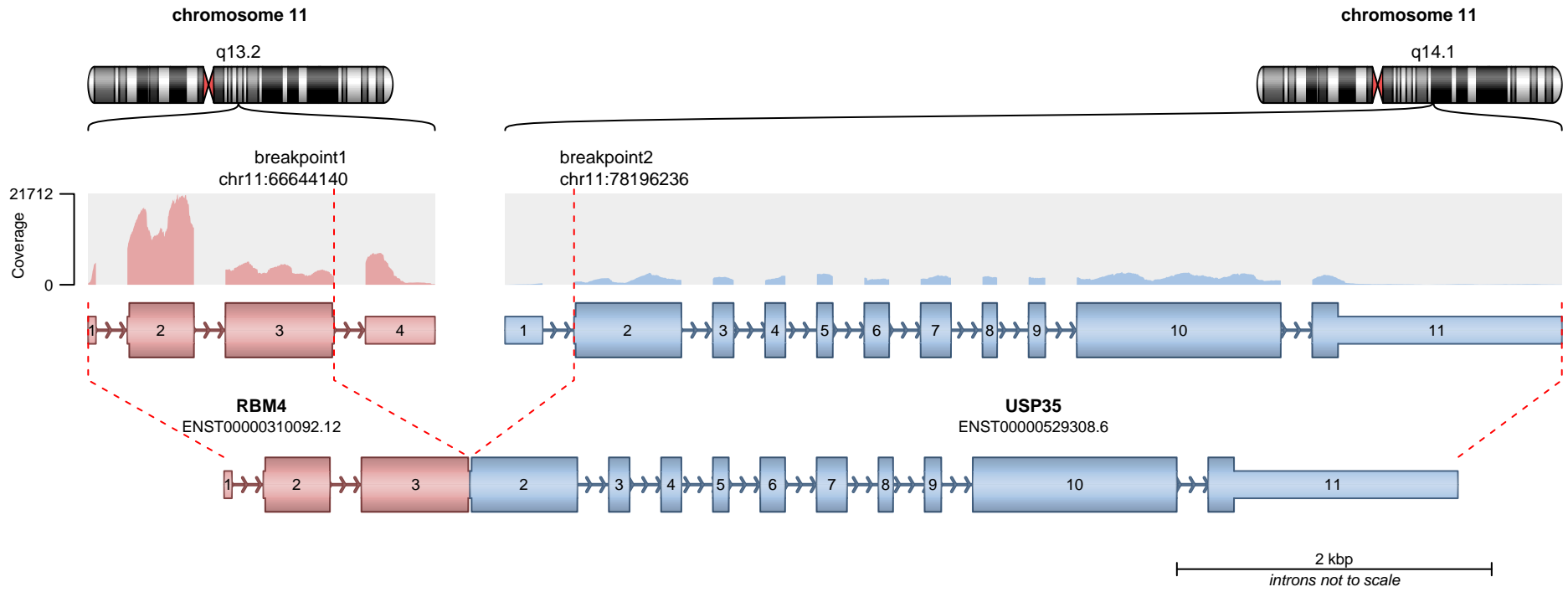

**RETAINED PROTEIN DOMAINS**  
reading frame unclear

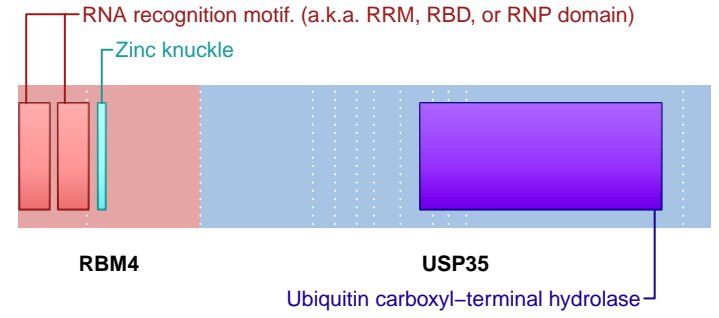

**SUPPORTING READ COUNT**

Split reads = 2  
Discordant mates = 0

- translocation
- duplication
- deletion
- inversion

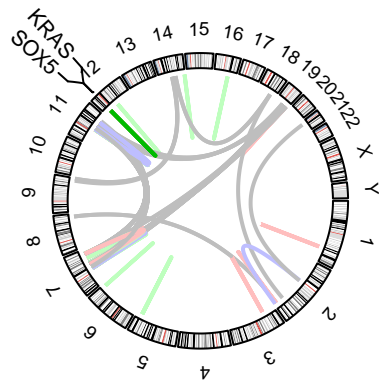
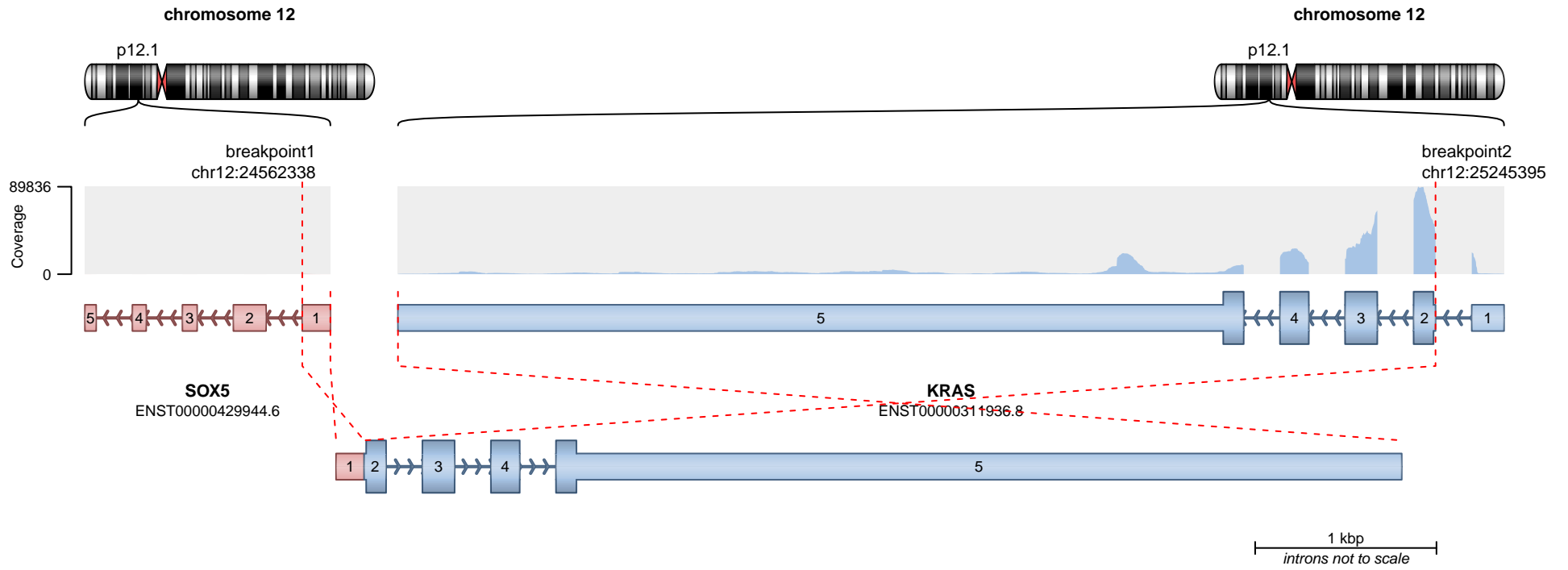

**RETAINED PROTEIN DOMAINS**  
reading frame unclear



Ras family

**SUPPORTING READ COUNT**

Split reads = 78  
Discordant mates = 0

— translocation    — deletion  
— duplication    — inversion

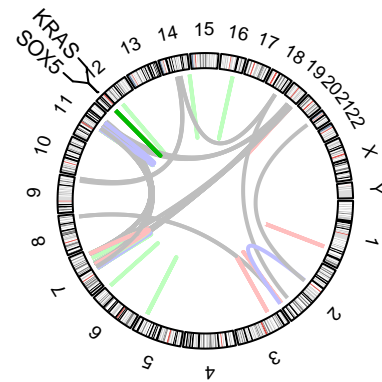
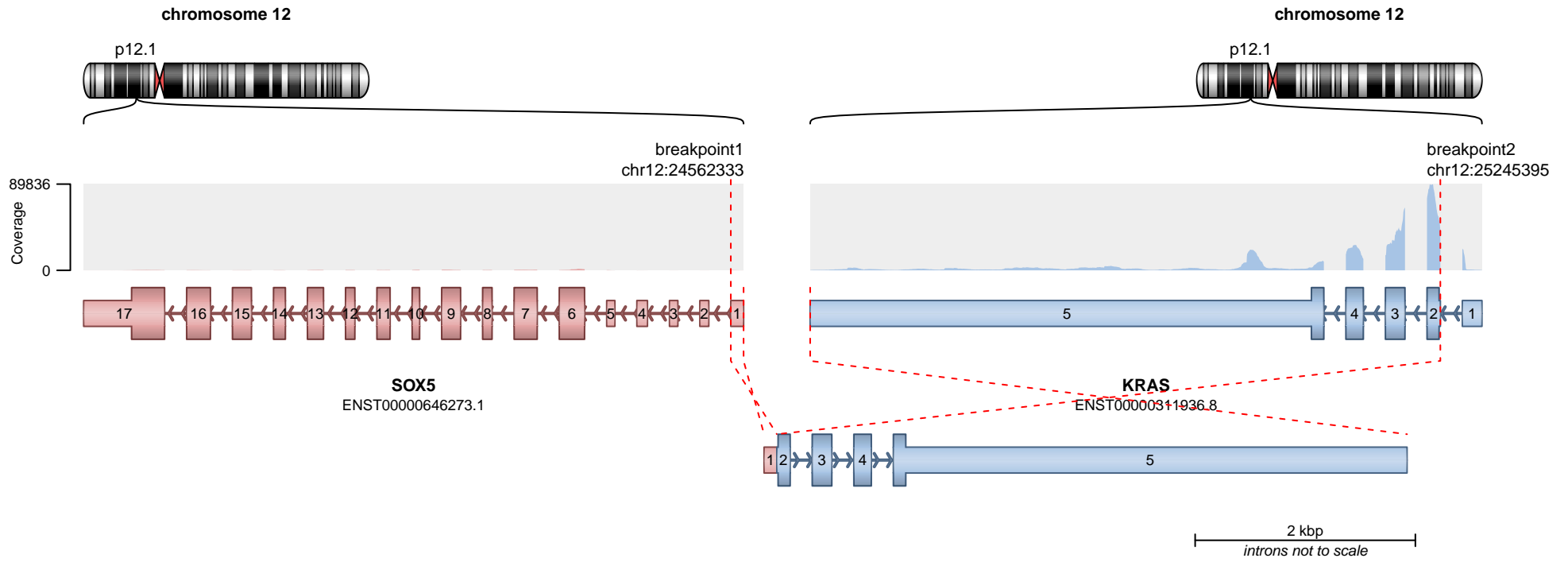

**RETAINED PROTEIN DOMAINS**  
reading frame unclear

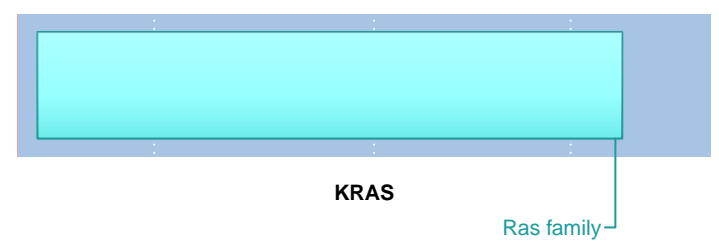

**SUPPORTING READ COUNT**

Split reads = 68  
Discordant mates = 0

— translocation    — deletion  
— duplication    — inversion

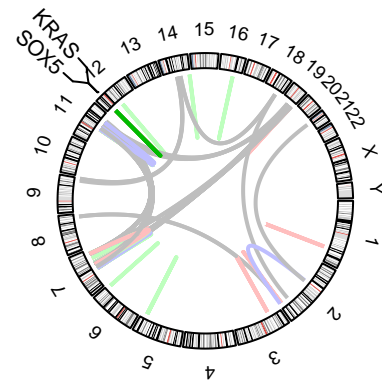
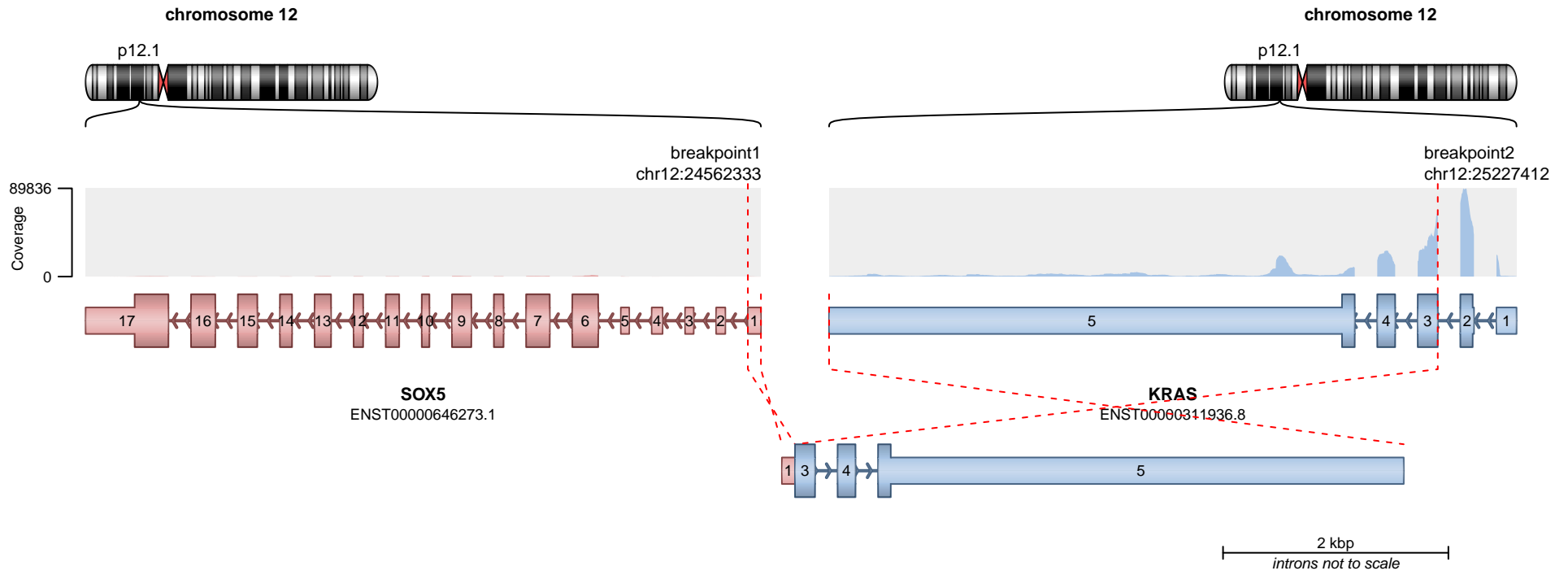

**RETAINED PROTEIN DOMAINS**  
reading frame unclear

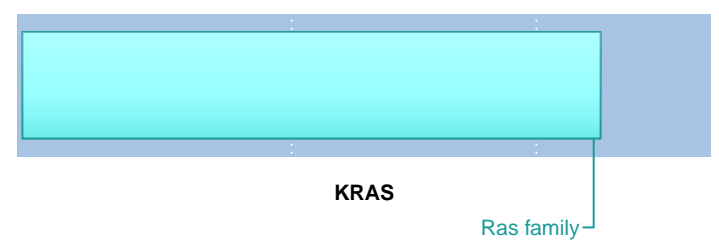

**SUPPORTING READ COUNT**

Split reads = 4  
Discordant mates = 0

— translocation — deletion  
— duplication — inversion

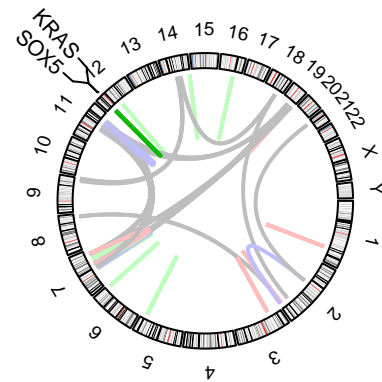
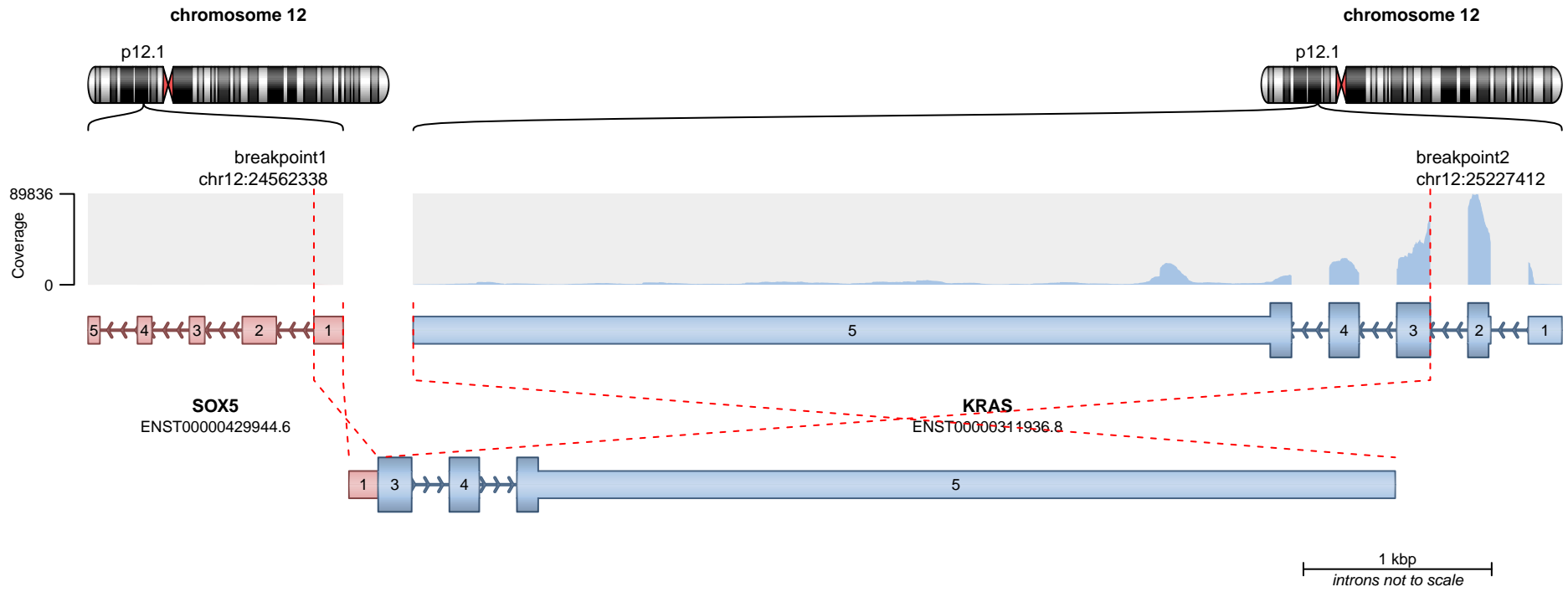

**RETAINED PROTEIN DOMAINS**  
reading frame unclear

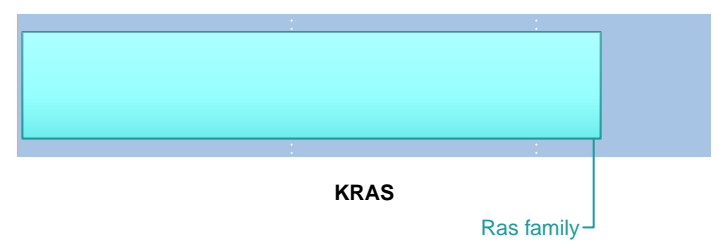

**SUPPORTING READ COUNT**

Split reads = 3  
Discordant mates = 0

— translocation    — deletion  
— duplication    — inversion

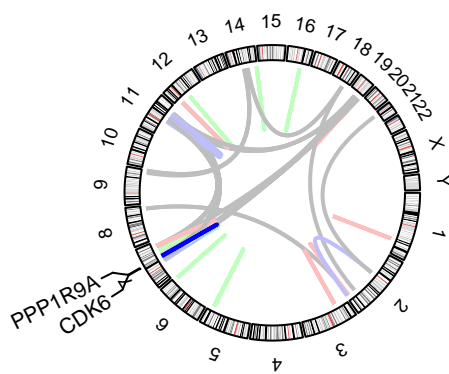
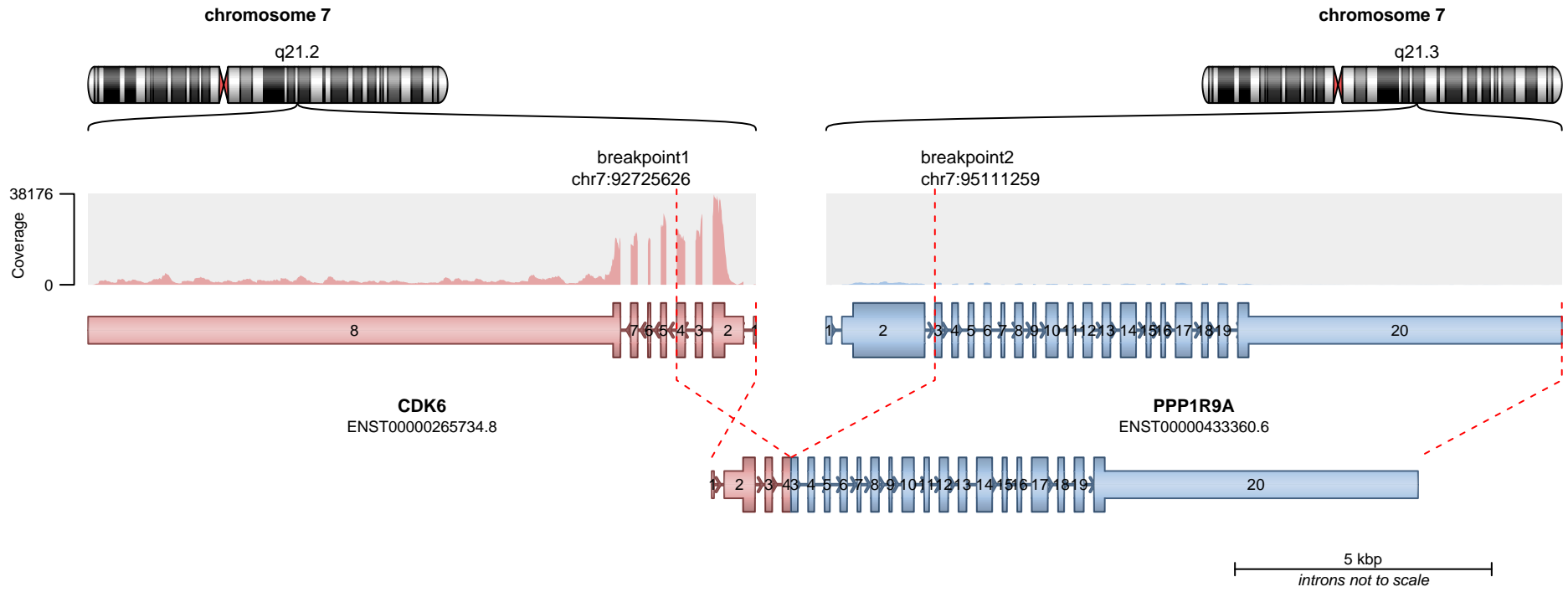

— translocation — deletion  
— duplication — inversion

**RETAINED PROTEIN DOMAINS**  
reading frame unclear

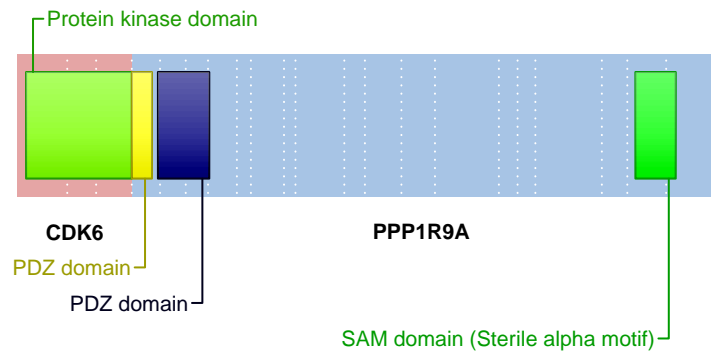

**SUPPORTING READ COUNT**

Split reads = 73  
Discordant mates = 3

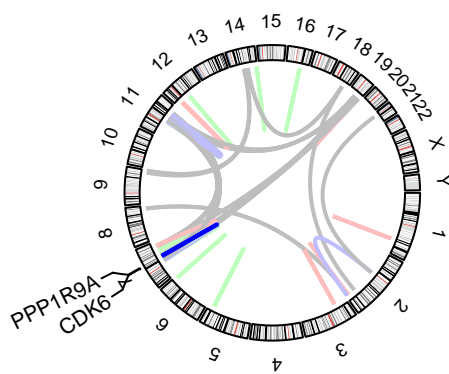
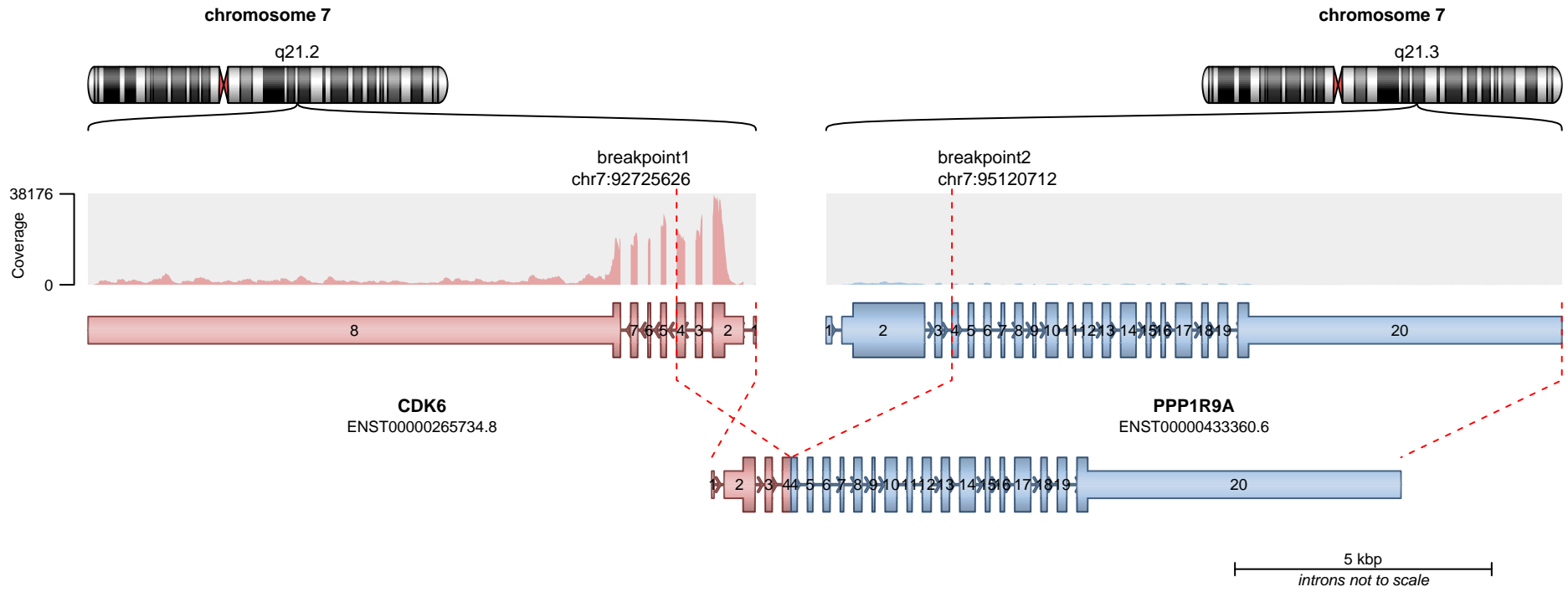

**RETAINED PROTEIN DOMAINS**  
reading frame unclear

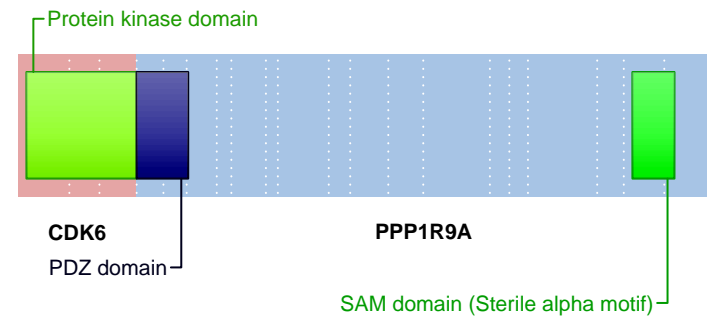

**SUPPORTING READ COUNT**

Split reads = 5  
Discordant mates = 0

- translocation
- duplication
- deletion
- inversion

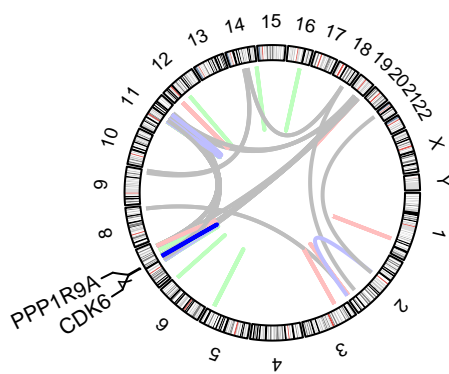
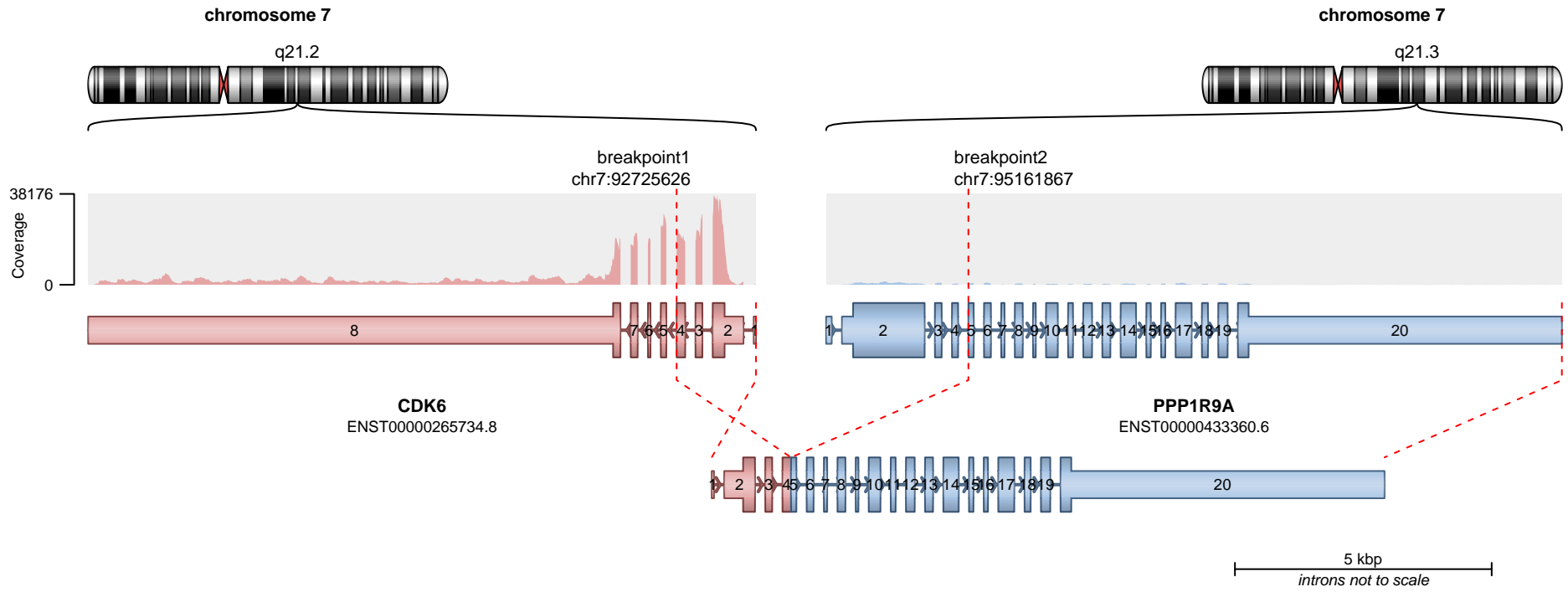

**RETAINED PROTEIN DOMAINS**  
reading frame unclear

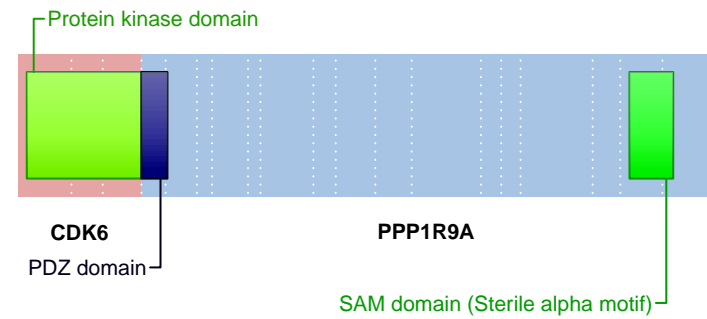

**SUPPORTING READ COUNT**

Split reads = 5  
Discordant mates = 0

- translocation
- duplication
- deletion
- inversion

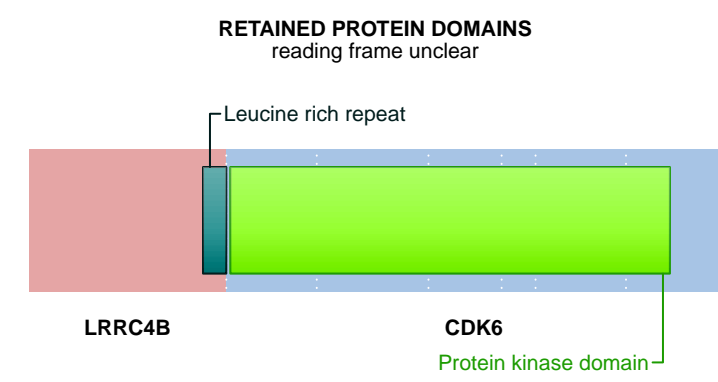
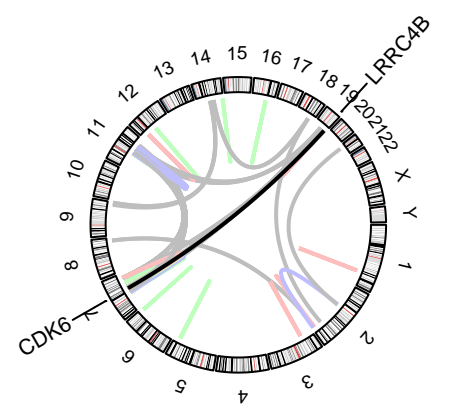
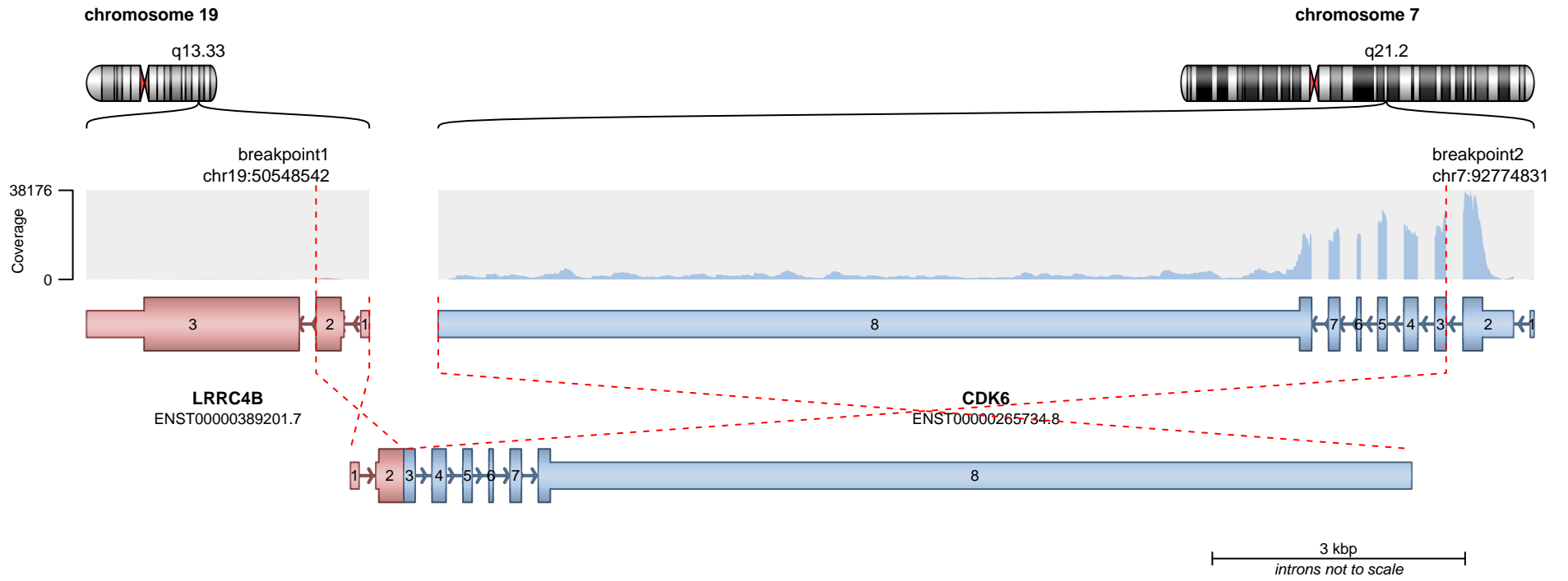

**SUPPORTING READ COUNT**

Split reads = 60  
Discordant mates = 0

— translocation    — deletion  
— duplication    — inversion

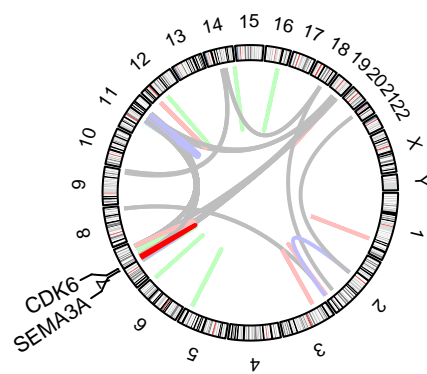
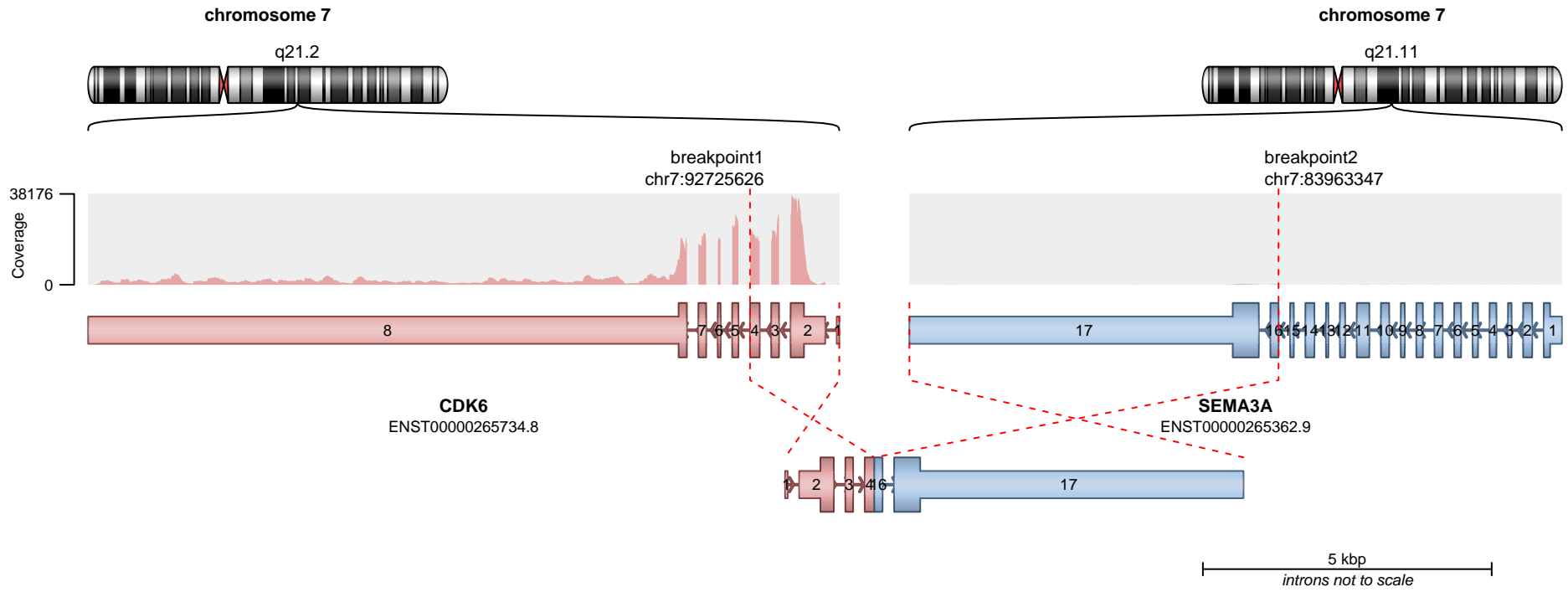

**RETAINED PROTEIN DOMAINS**  
reading frame unclear

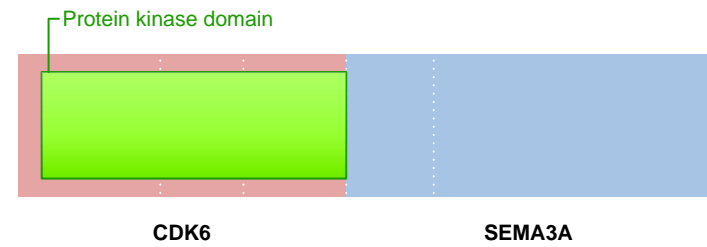

**SUPPORTING READ COUNT**

Split reads = 49  
Discordant mates = 0

- translocation
- duplication
- deletion
- inversion

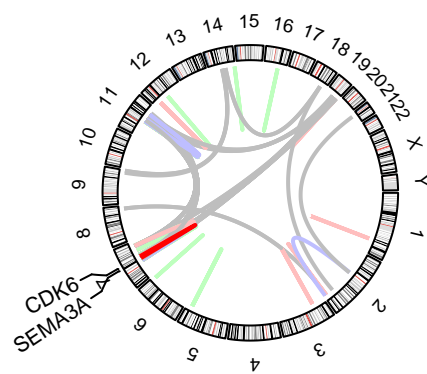
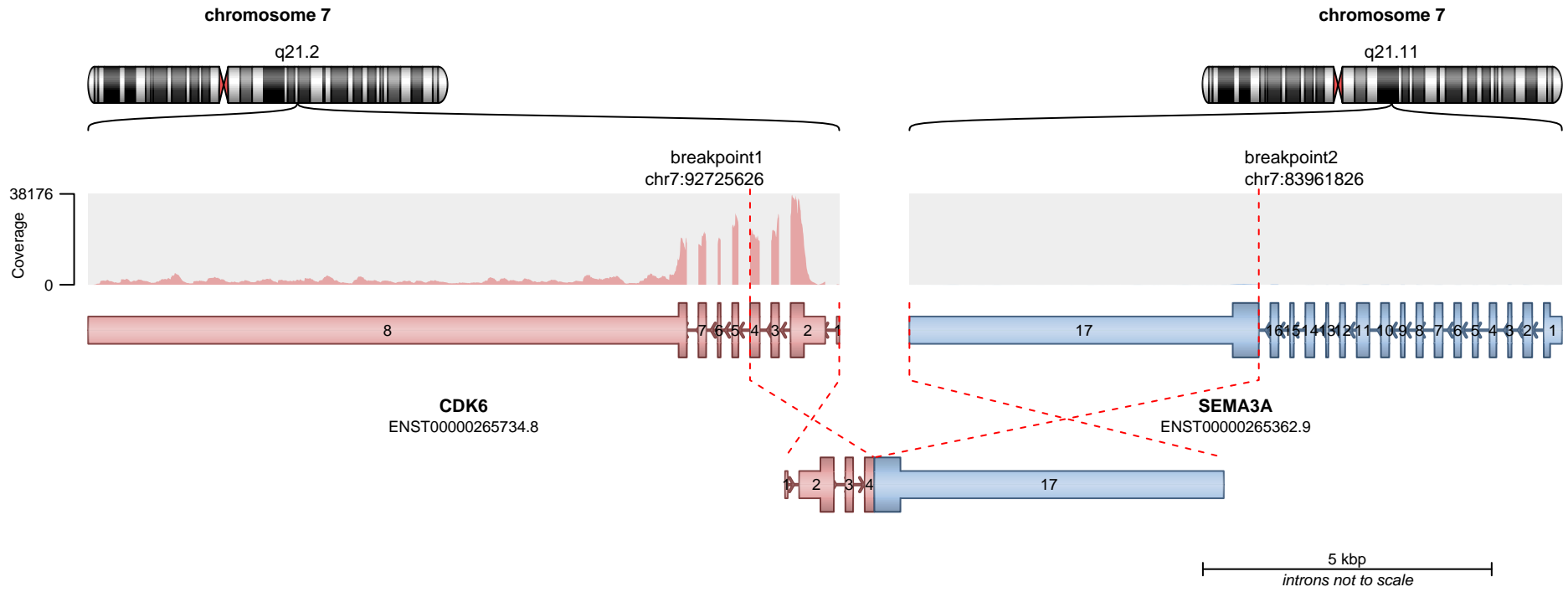

**RETAINED PROTEIN DOMAINS**  
reading frame unclear

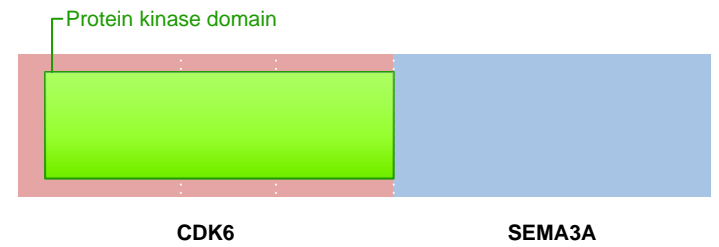

**SUPPORTING READ COUNT**

Split reads = 2  
Discordant mates = 0

- translocation
- duplication
- deletion
- inversion

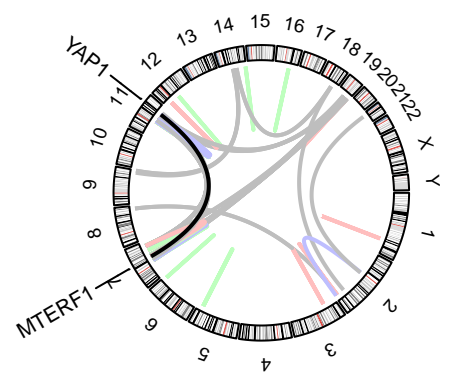
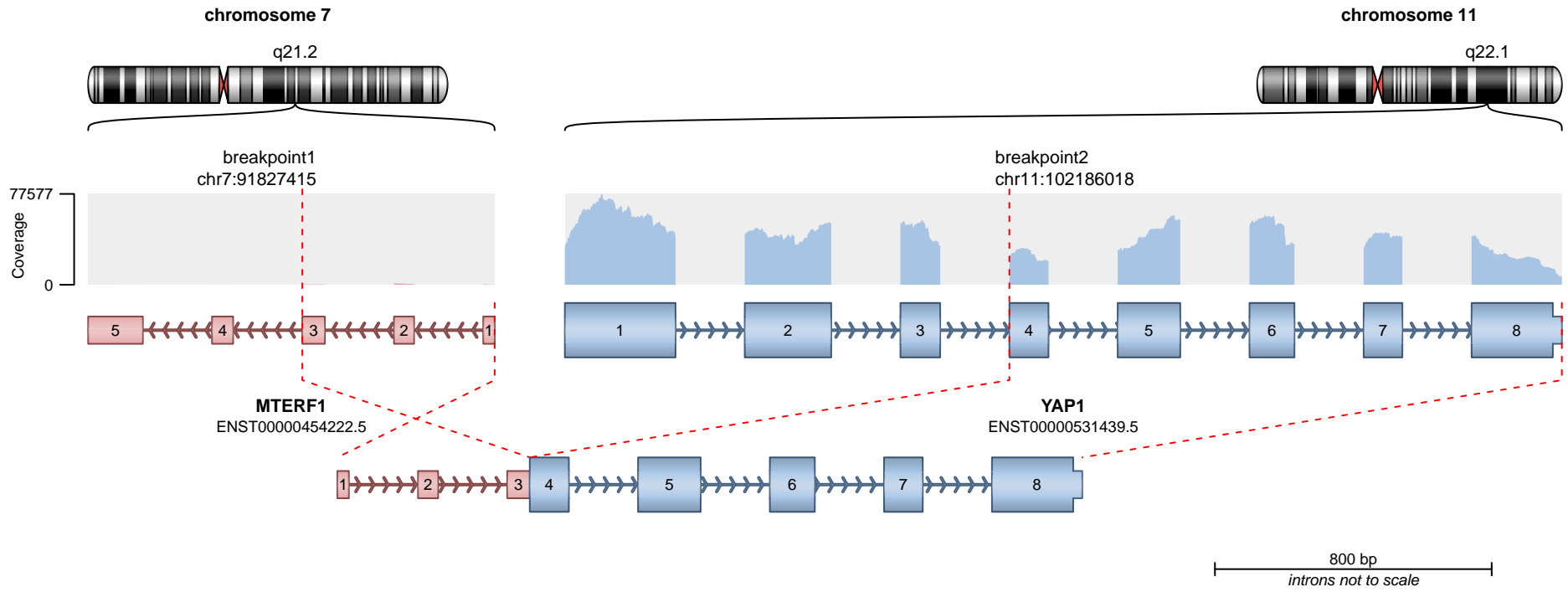

**RETAINED PROTEIN DOMAINS**  
reading frame unclear

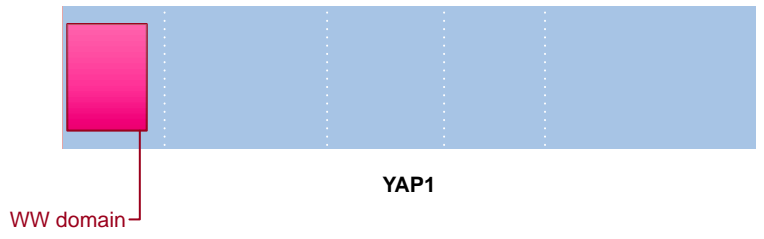

**SUPPORTING READ COUNT**

Split reads = 47  
Discordant mates = 0

- translocation
- duplication
- deletion
- inversion

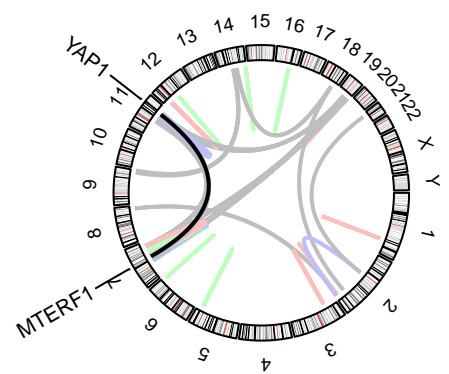
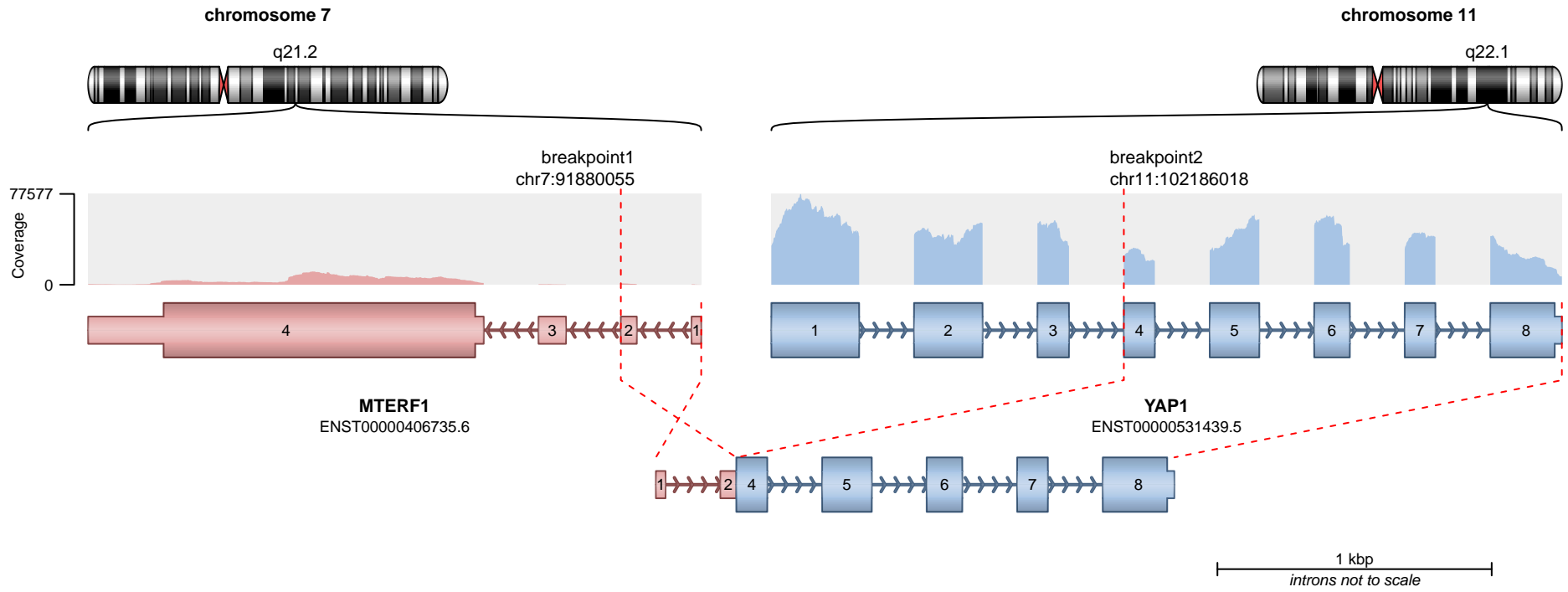

**RETAINED PROTEIN DOMAINS**  
reading frame unclear

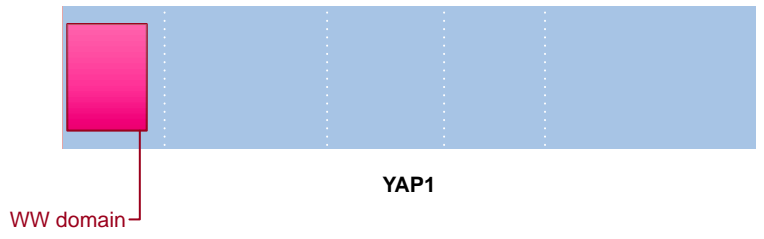

**SUPPORTING READ COUNT**

Split reads = 29  
Discordant mates = 0

- translocation
- duplication
- deletion
- inversion

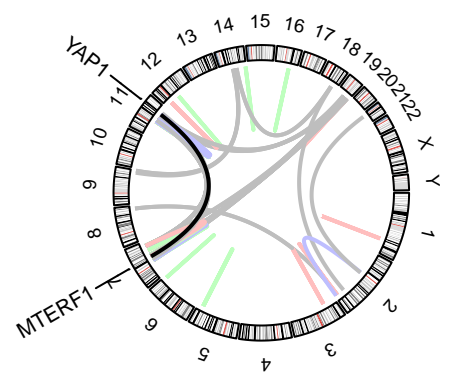
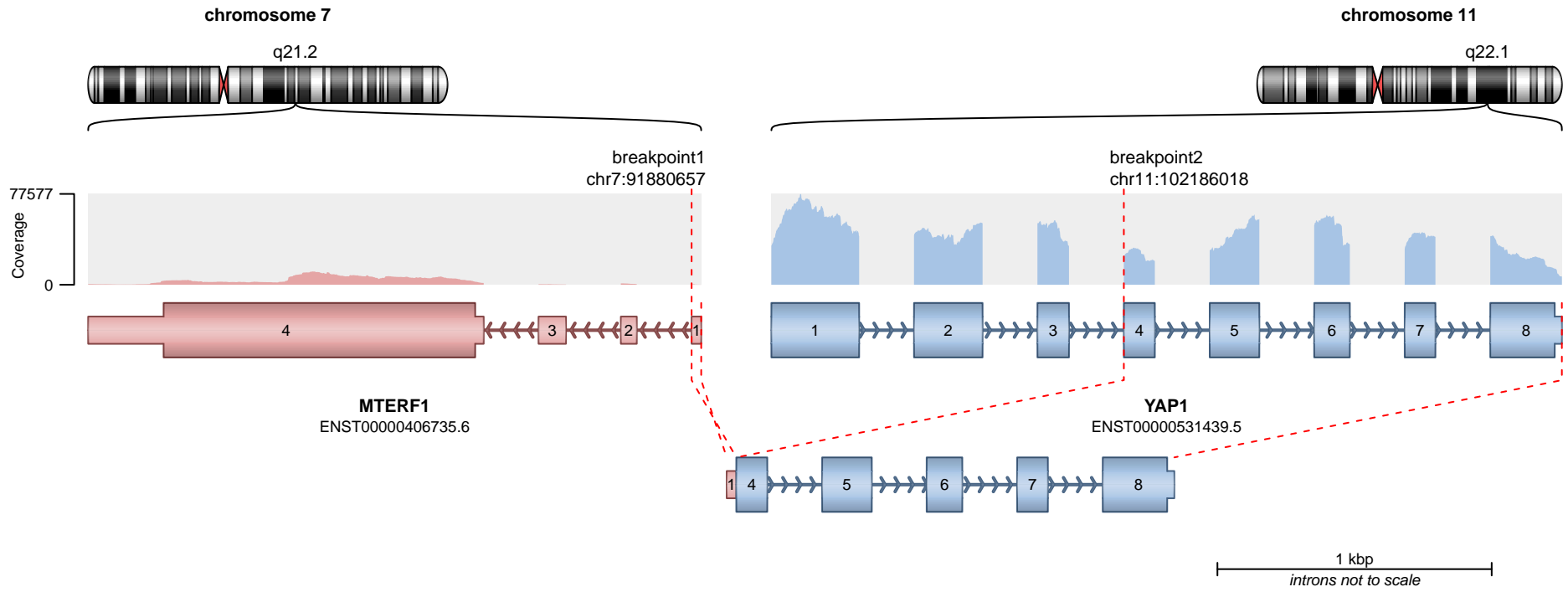

**RETAINED PROTEIN DOMAINS**  
reading frame unclear

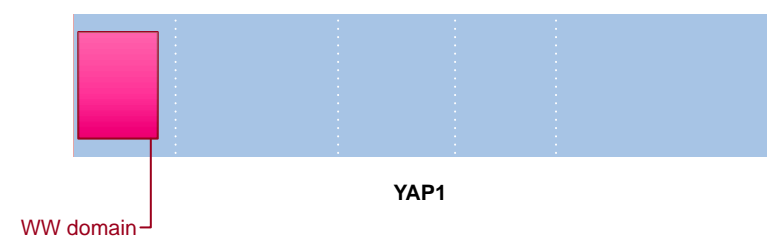

**SUPPORTING READ COUNT**

Split reads = 5  
Discordant mates = 0

- translocation
- duplication
- deletion
- inversion

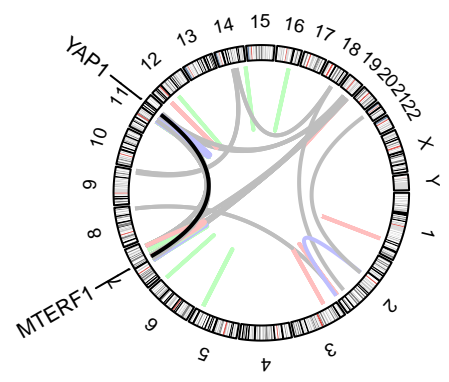
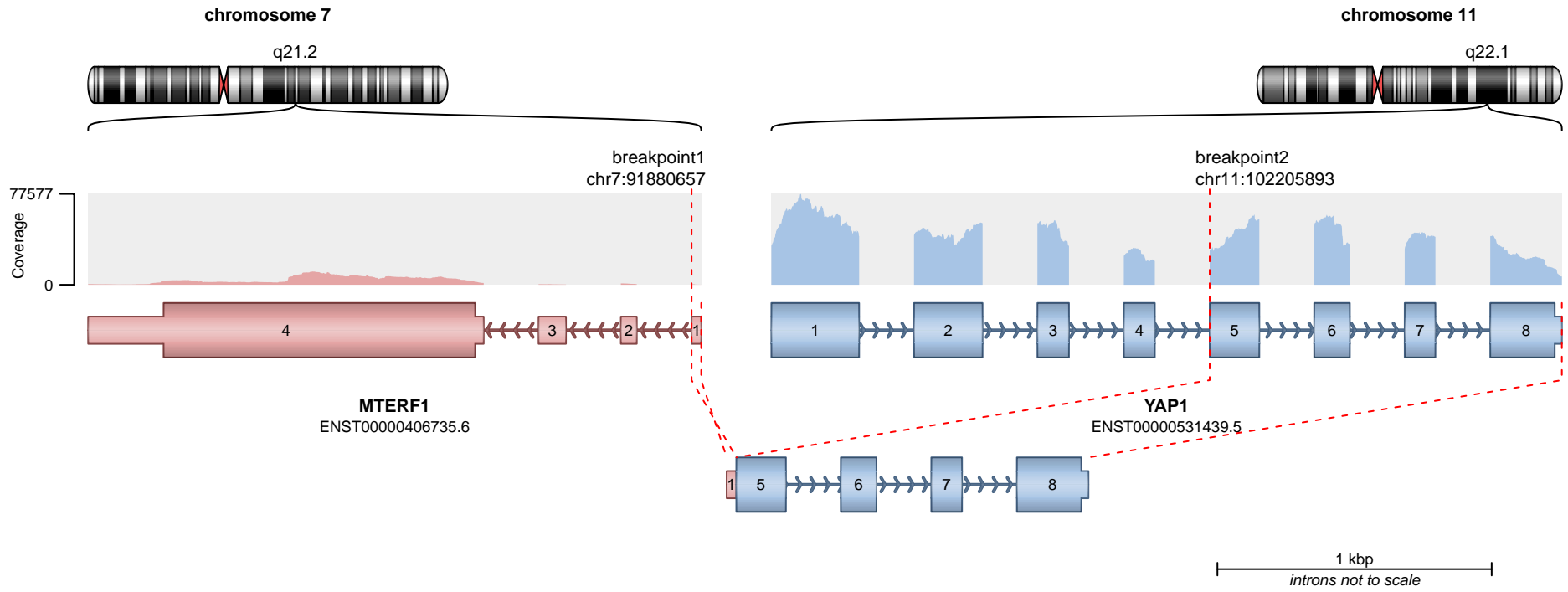

— translocation    — deletion  
— duplication    — inversion

No protein domains retained in fusion.

**SUPPORTING READ COUNT**

Split reads = 5  
Discordant mates = 0

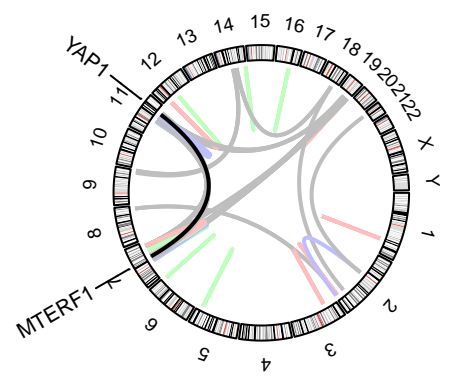
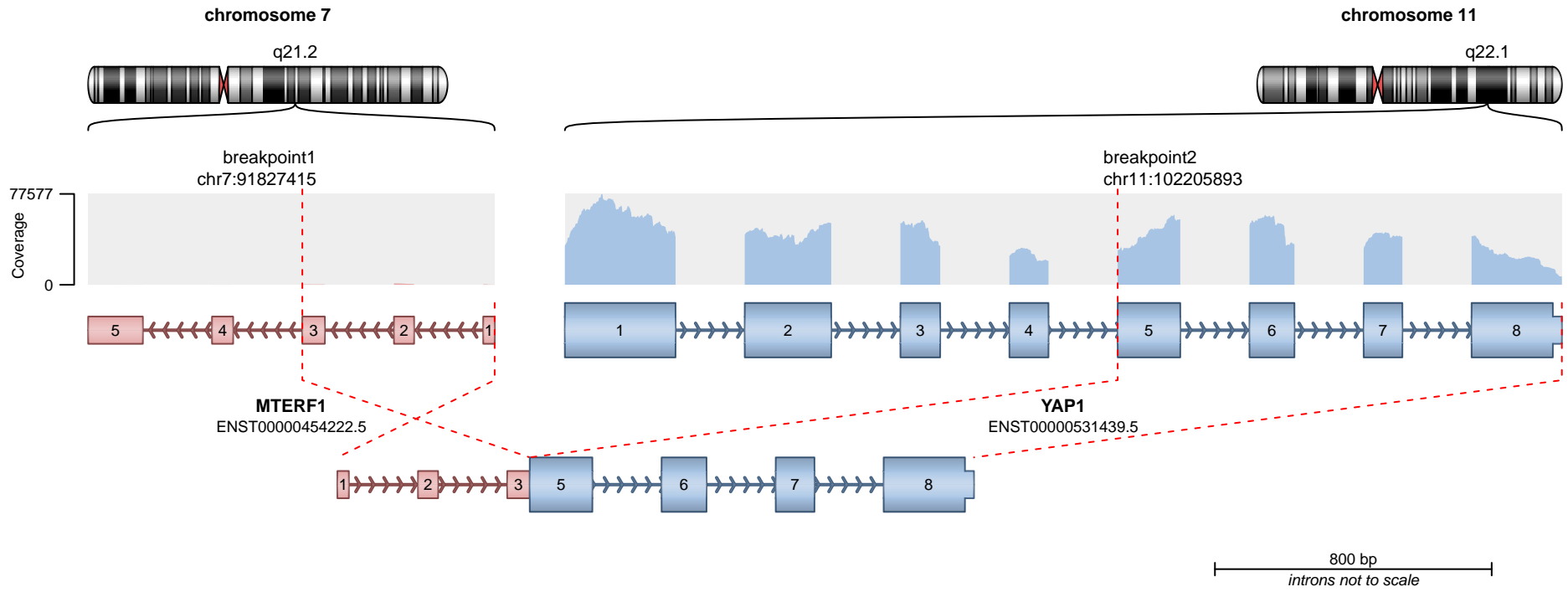

— translocation    — deletion  
— duplication    — inversion

No protein domains retained in fusion.

**SUPPORTING READ COUNT**

Split reads = 4  
Discordant mates = 0

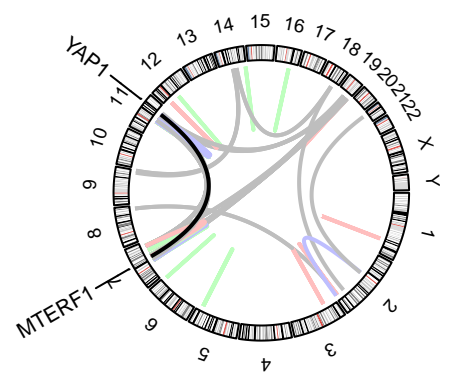
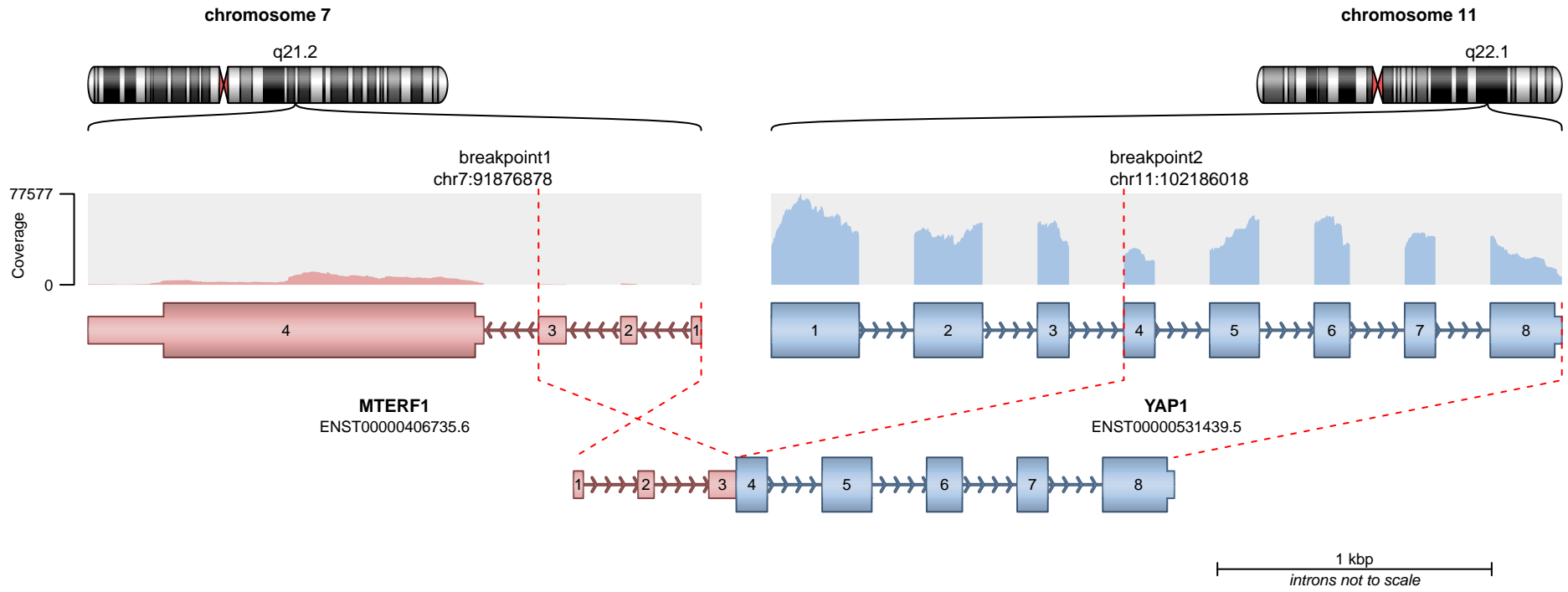

**RETAINED PROTEIN DOMAINS**  
reading frame unclear

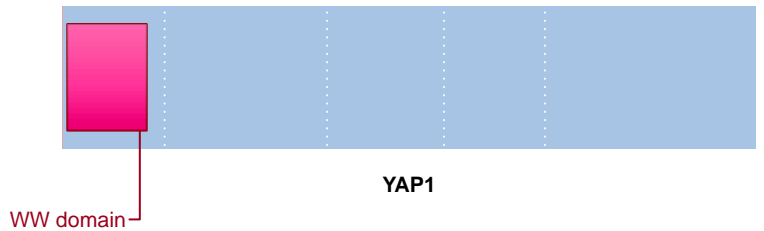

**SUPPORTING READ COUNT**

Split reads = 4  
Discordant mates = 0

- translocation
- duplication
- deletion
- inversion

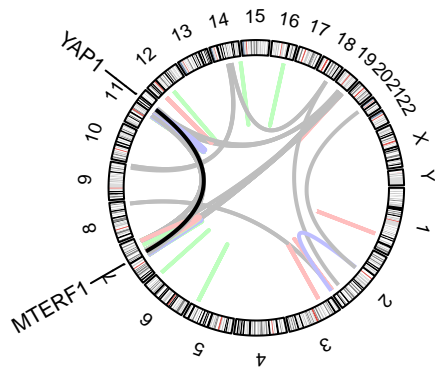
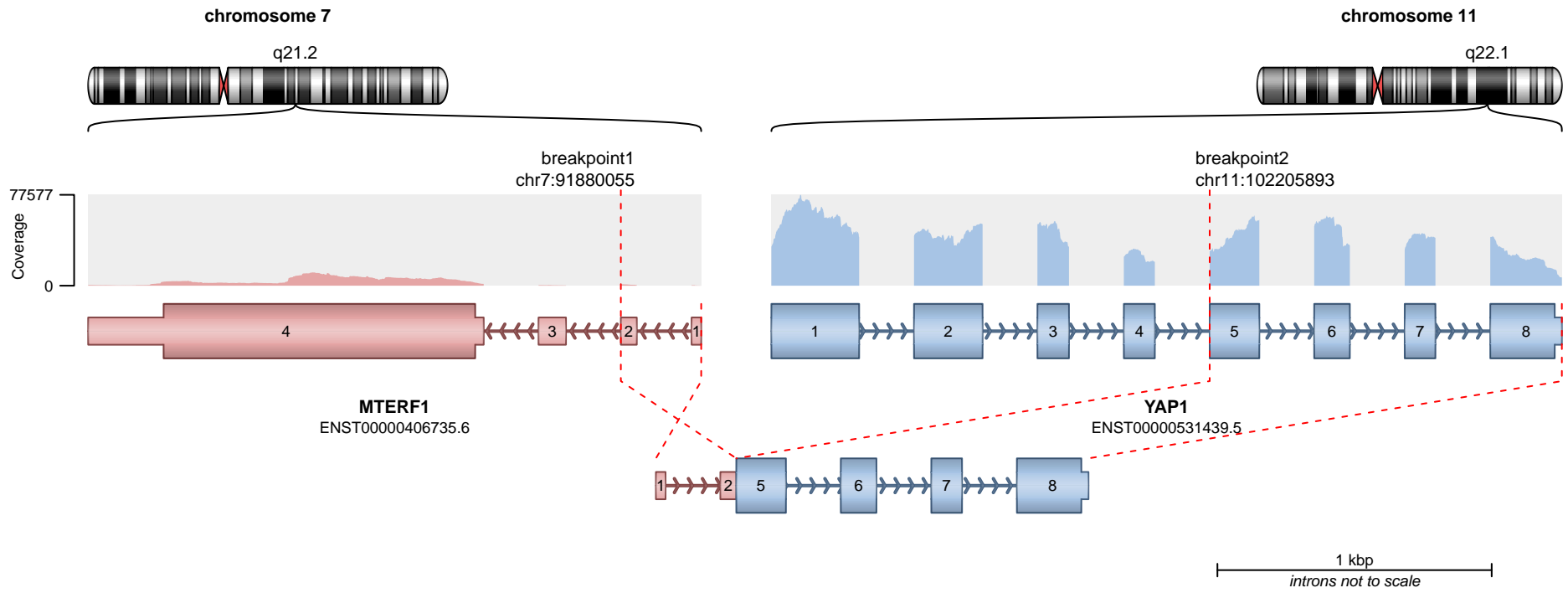

— translocation — deletion  
— duplication — inversion

No protein domains retained in fusion.

**SUPPORTING READ COUNT**

Split reads = 2  
Discordant mates = 0

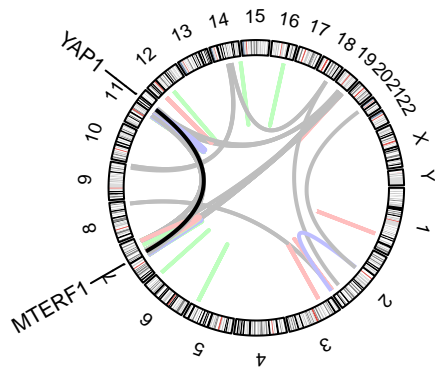
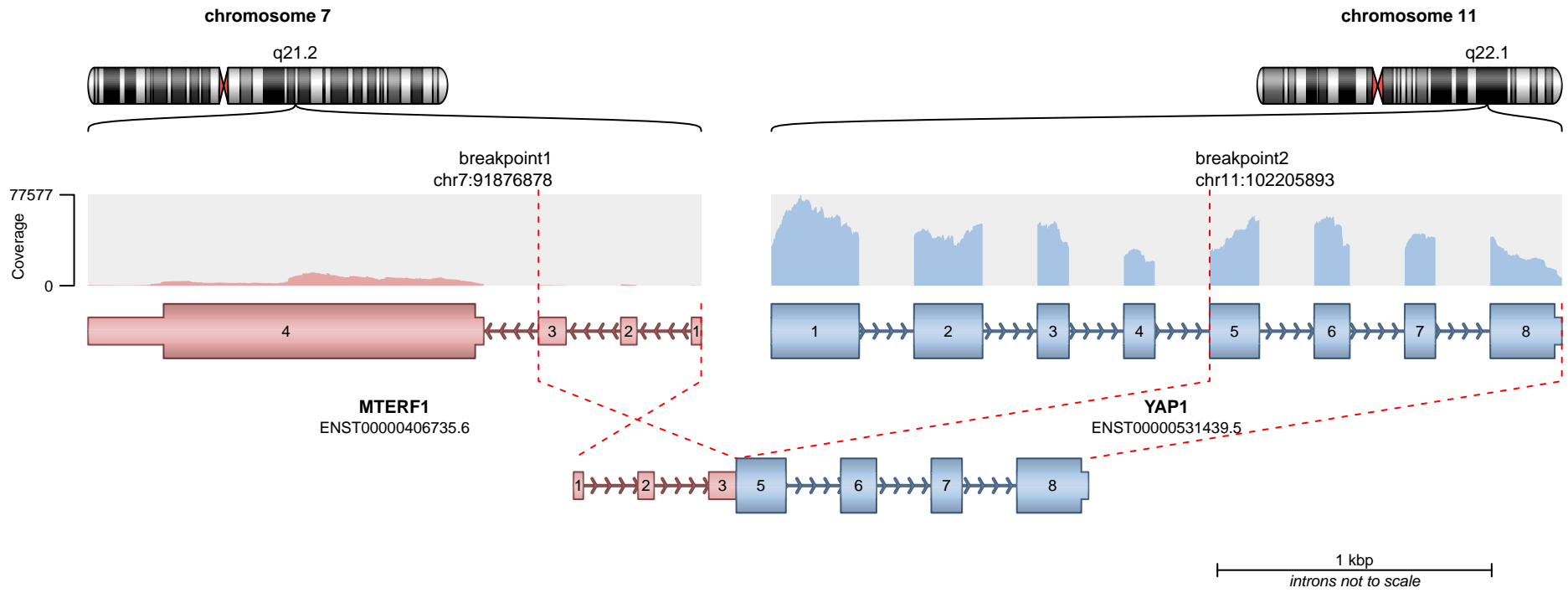

— translocation — deletion  
— duplication — inversion

No protein domains retained in fusion.

**SUPPORTING READ COUNT**

Split reads = 1  
Discordant mates = 0

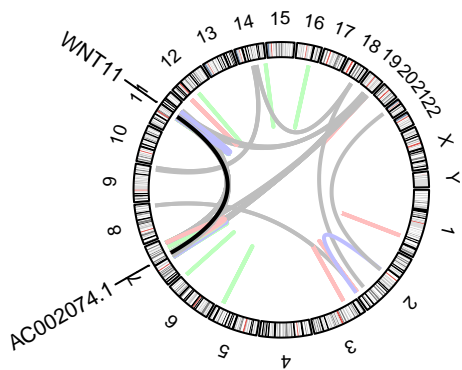
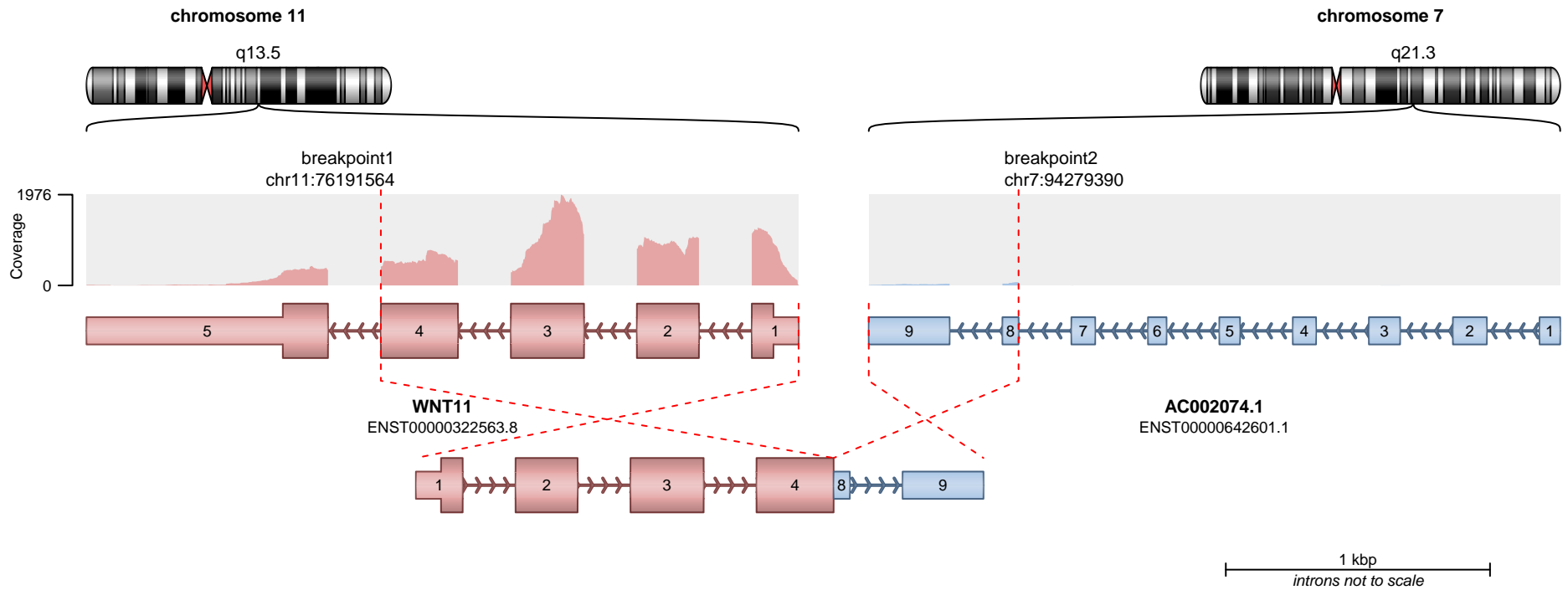

— translocation    — deletion  
— duplication    — inversion

**RETAINED PROTEIN DOMAINS**  
reading frame unclear

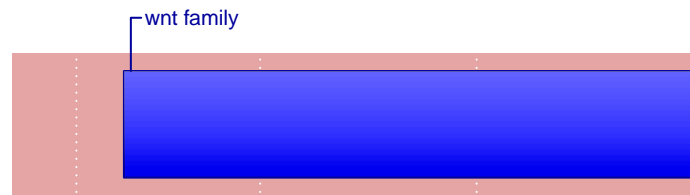

**SUPPORTING READ COUNT**

Split reads = 45  
Discordant mates = 2

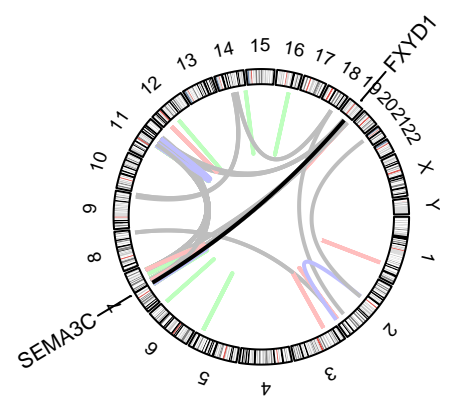
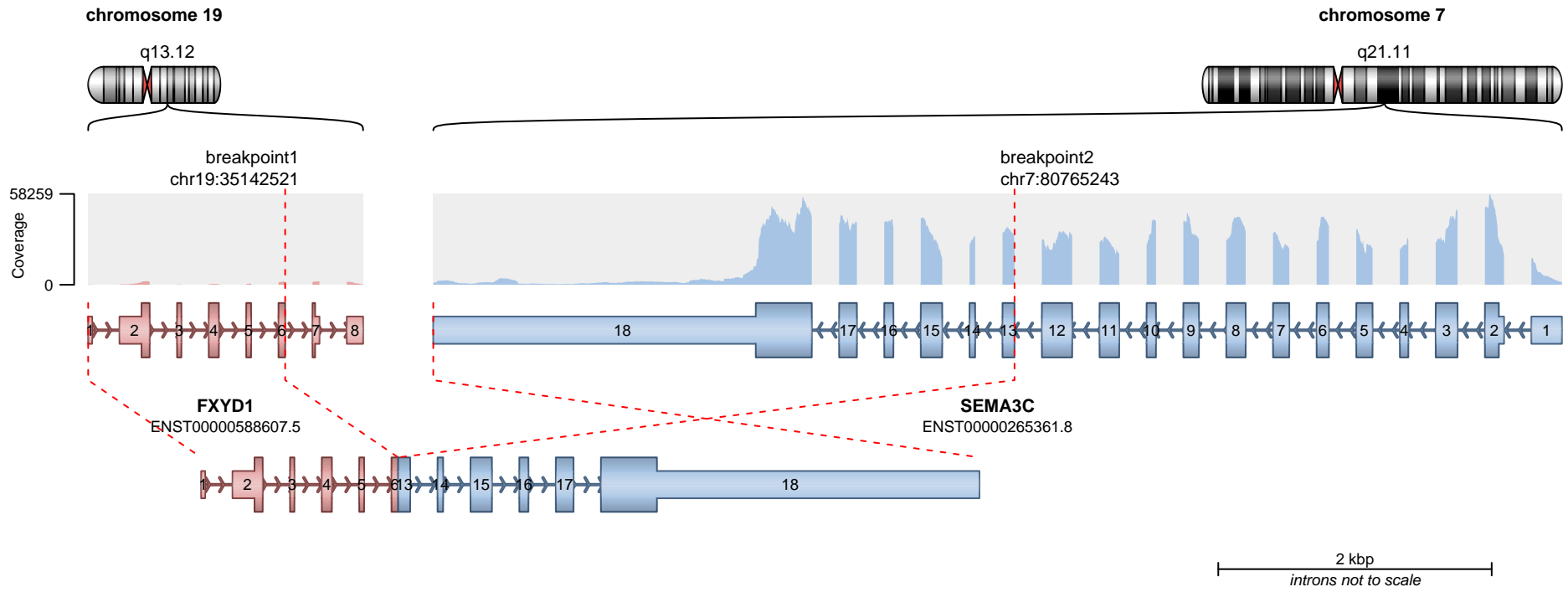

**RETAINED PROTEIN DOMAINS**  
reading frame unclear

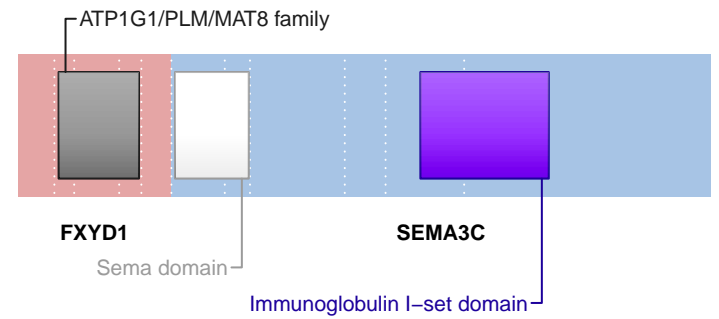

**SUPPORTING READ COUNT**

Split reads = 40  
Discordant mates = 0

- translocation
- duplication
- deletion
- inversion

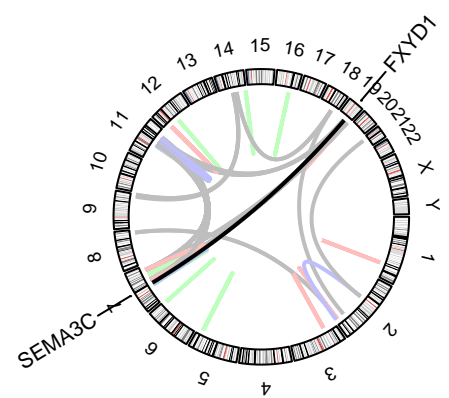
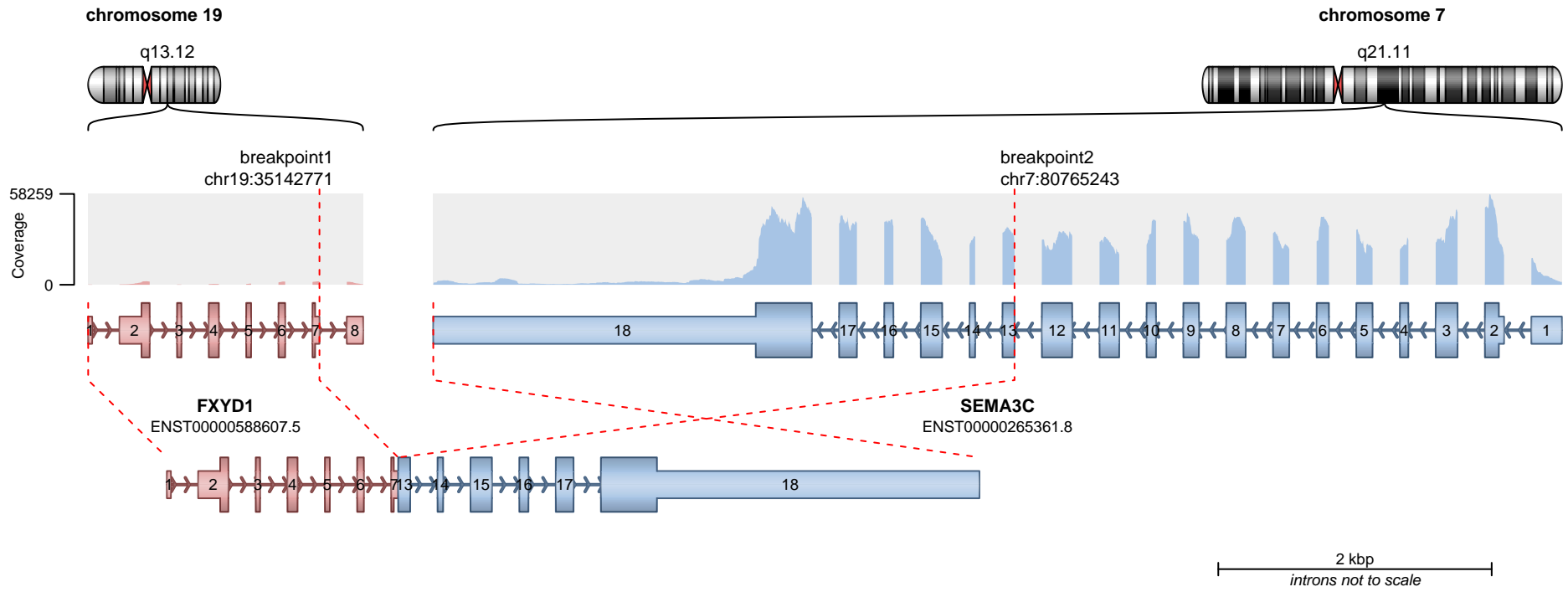

— translocation — deletion  
— duplication — inversion

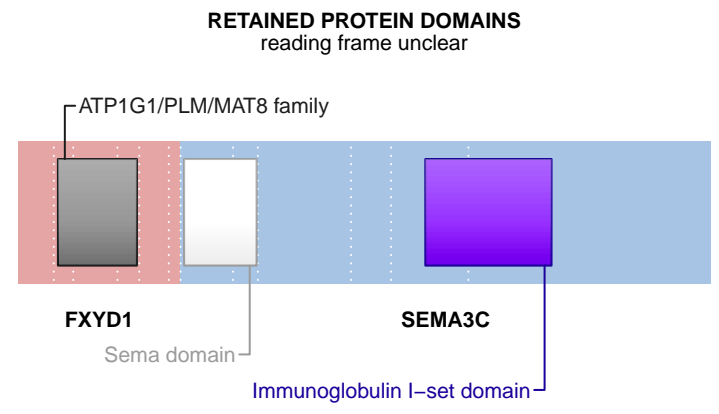

**SUPPORTING READ COUNT**

Split reads = 16  
Discordant mates = 0

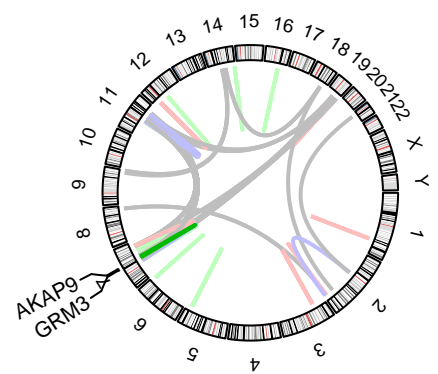
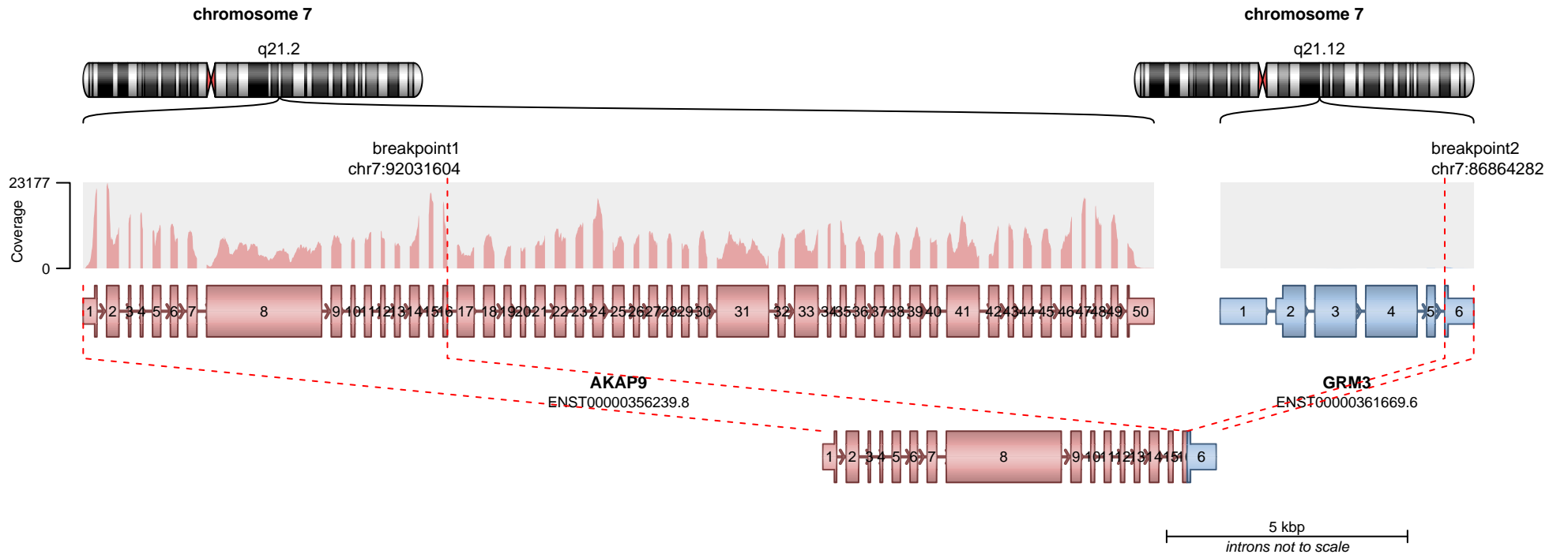

No protein domains retained in fusion.

**SUPPORTING READ COUNT**

Split reads = 39  
Discordant mates = 1

- translocation
- duplication
- deletion
- inversion

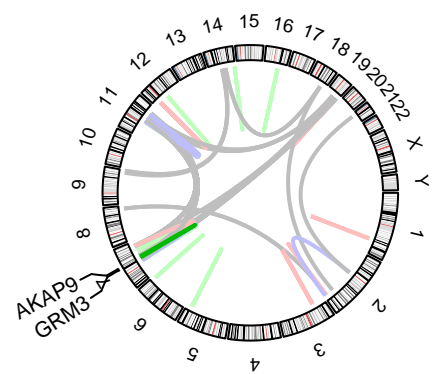
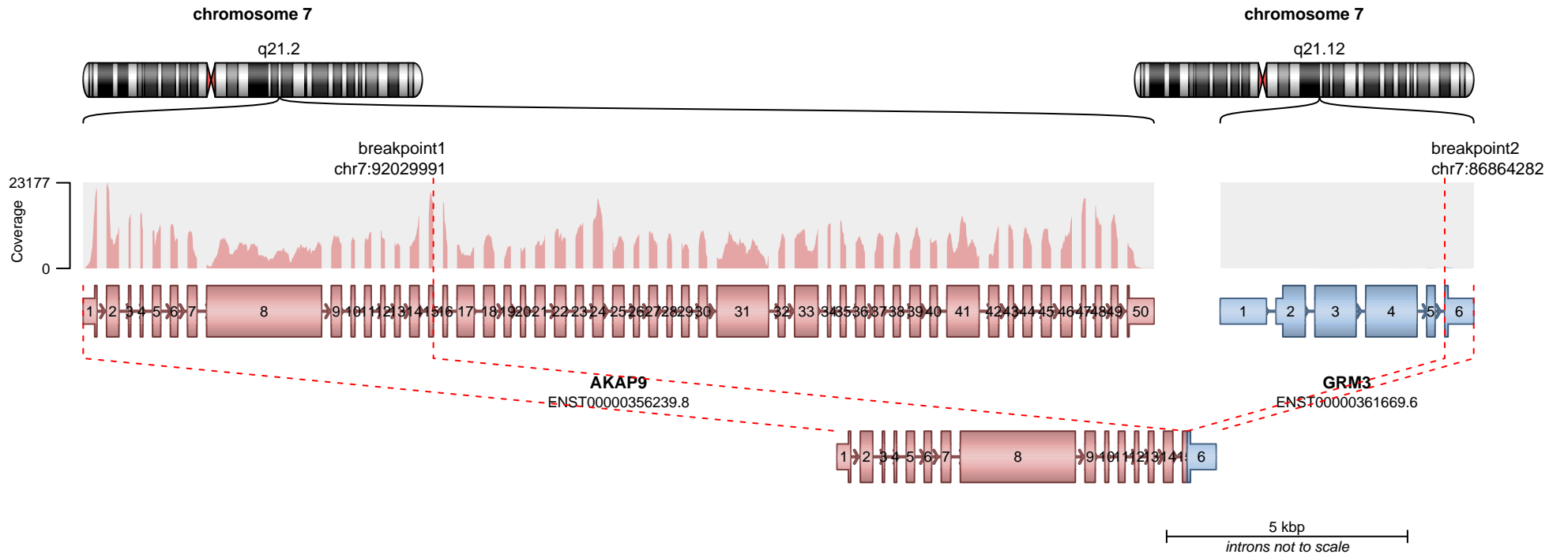

No protein domains retained in fusion.

**SUPPORTING READ COUNT**

Split reads = 19  
Discordant mates = 0

- translocation
- duplication
- deletion
- inversion

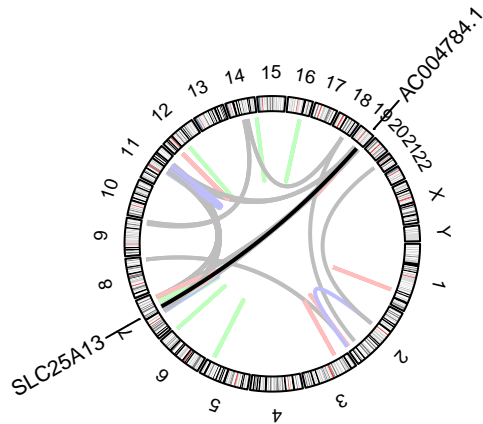
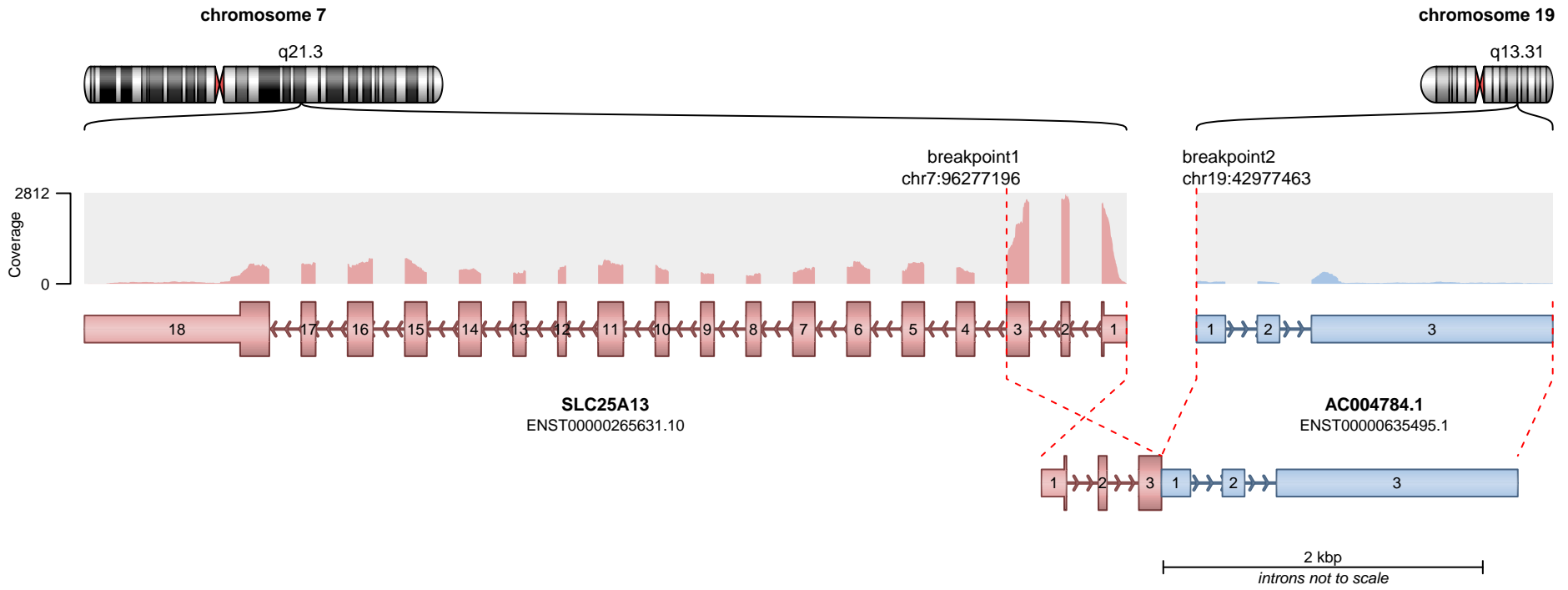

— translocation    — deletion  
— duplication    — inversion

No protein domains retained in fusion.

**SUPPORTING READ COUNT**

Split reads = 38  
Discordant mates = 2

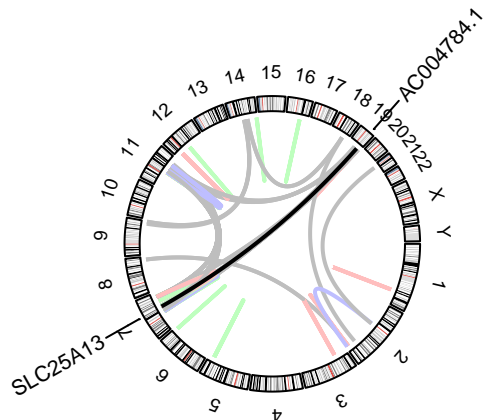
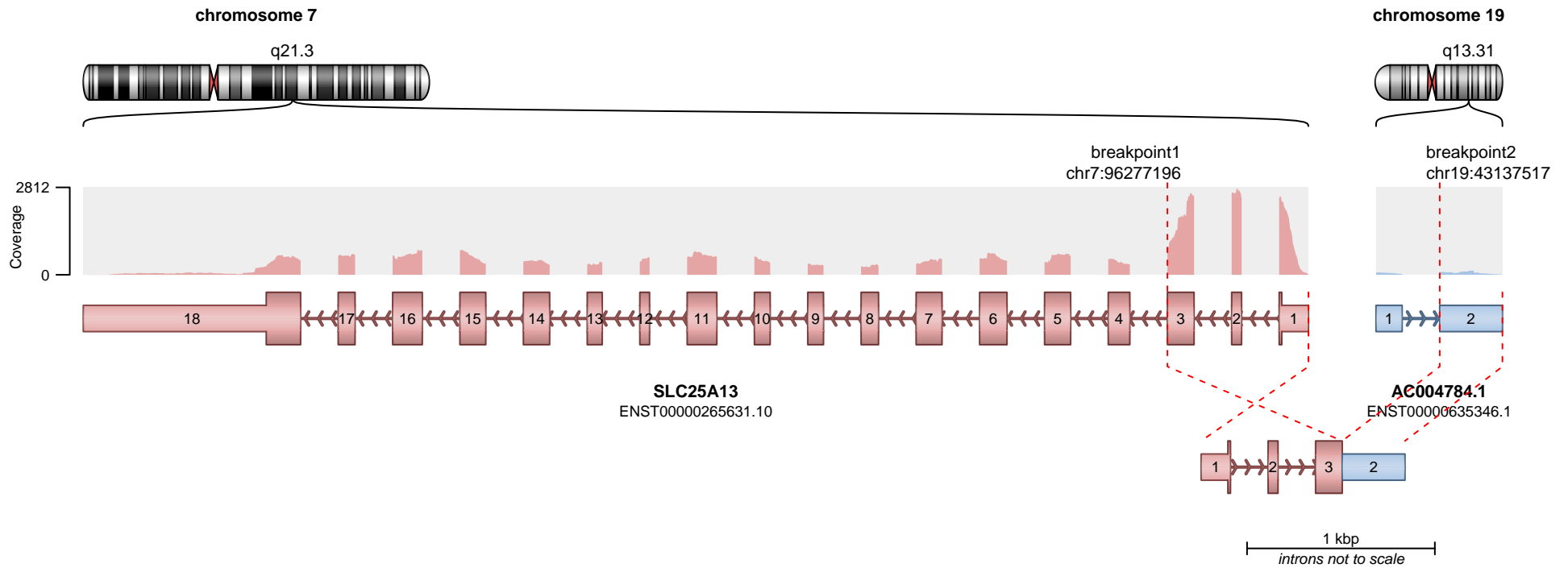

— translocation    — deletion  
— duplication    — inversion

No protein domains retained in fusion.

**SUPPORTING READ COUNT**

Split reads = 32  
Discordant mates = 0

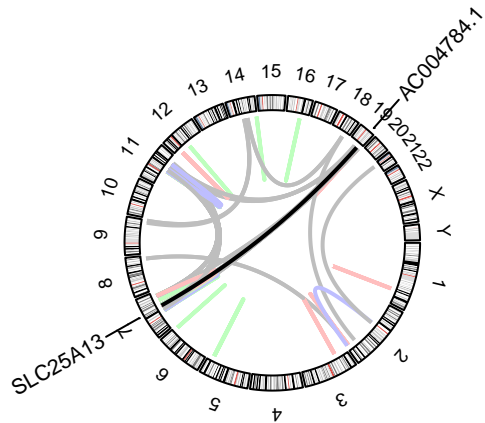
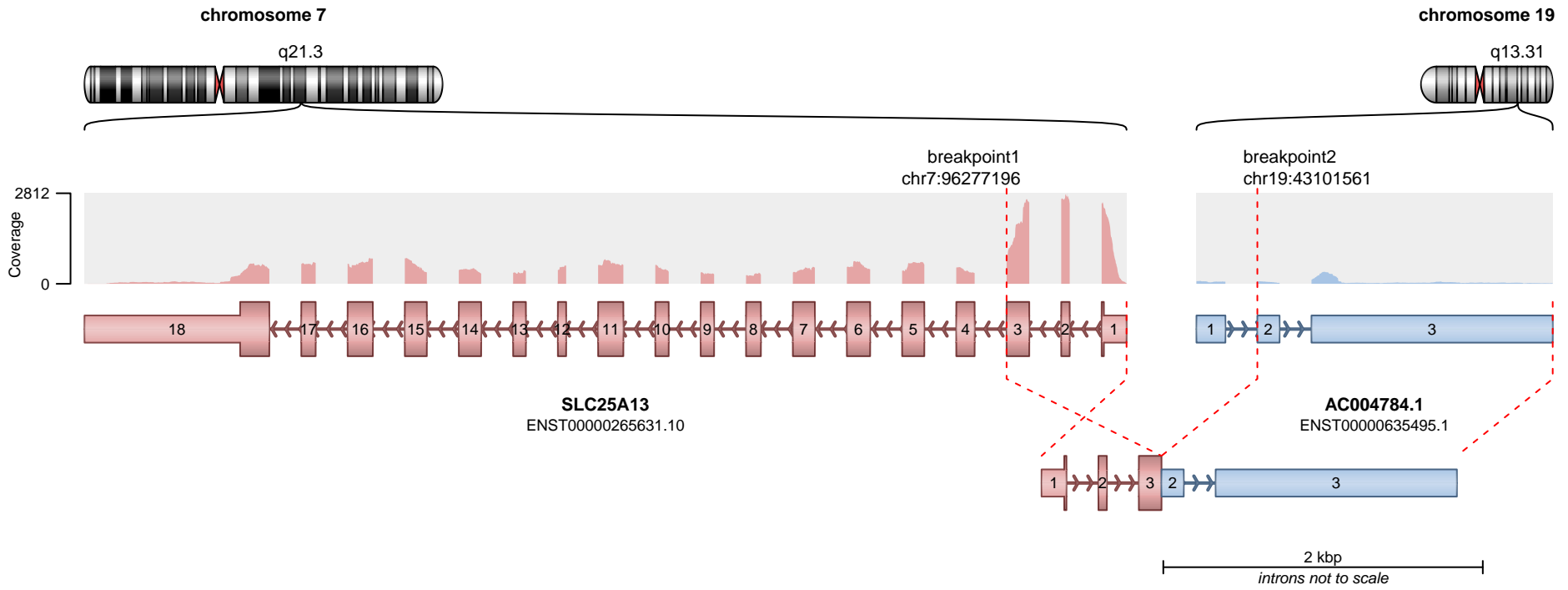

— translocation    — deletion  
— duplication    — inversion

No protein domains retained in fusion.

**SUPPORTING READ COUNT**

Split reads = 30  
Discordant mates = 1

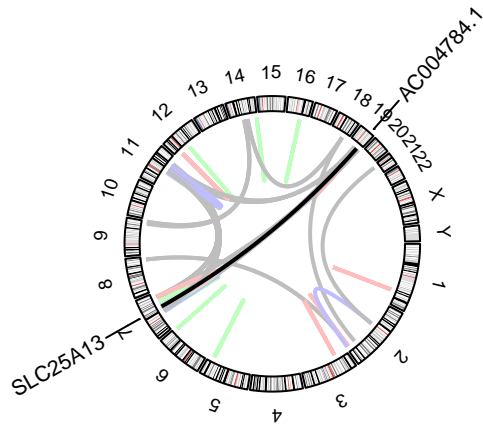
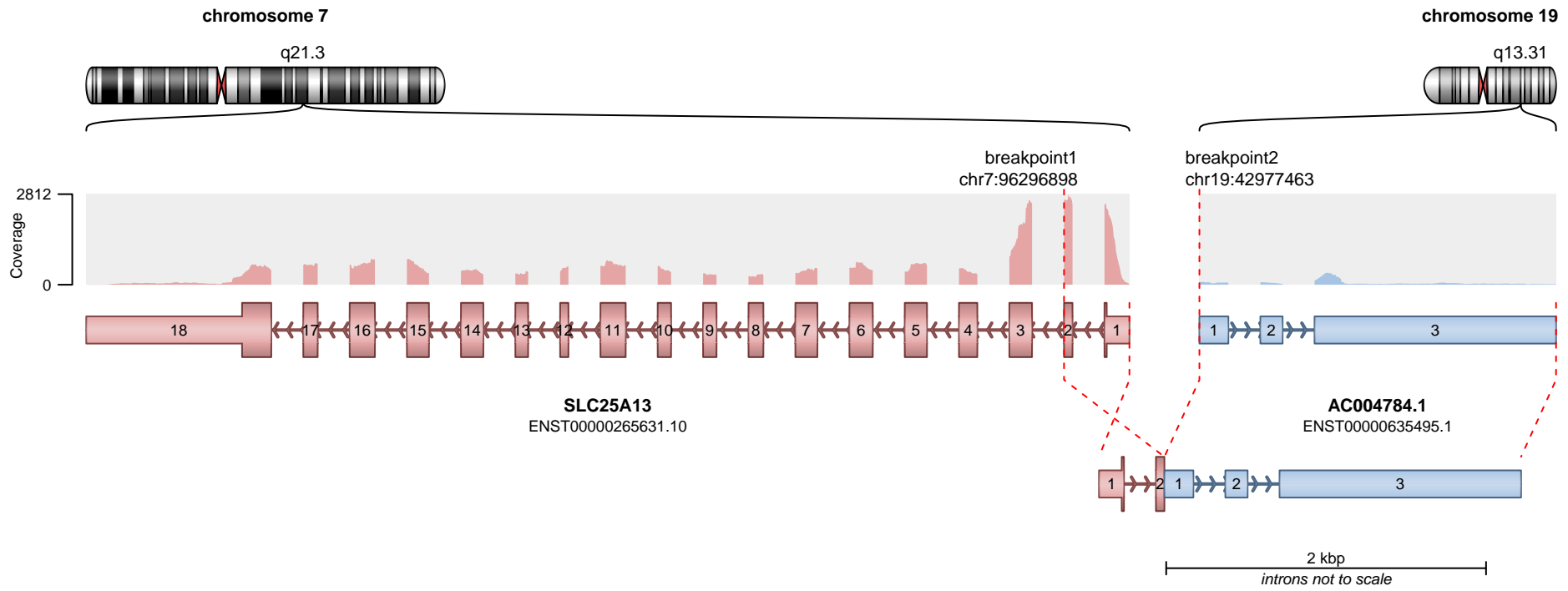

No protein domains retained in fusion.

**SUPPORTING READ COUNT**

Split reads = 7  
Discordant mates = 1

— translocation    — deletion  
— duplication    — inversion

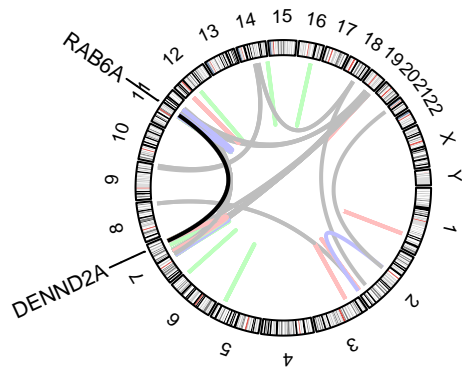
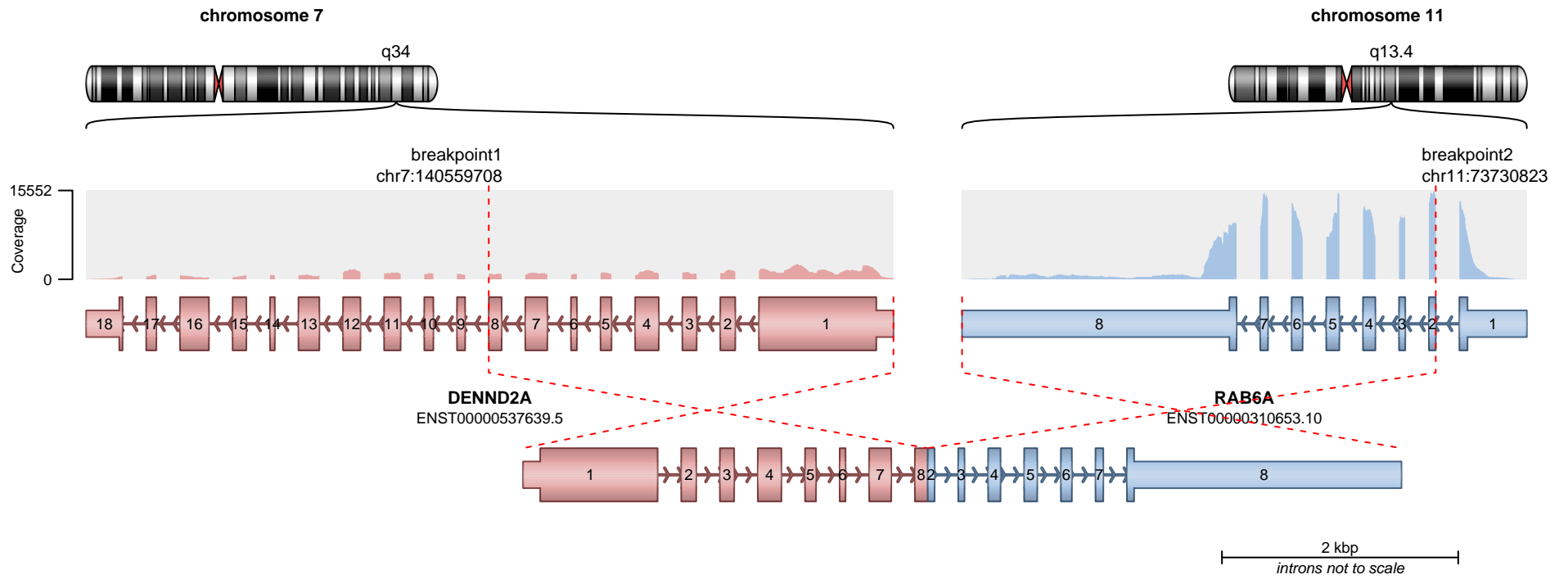

**RETAINED PROTEIN DOMAINS**  
reading frame unclear

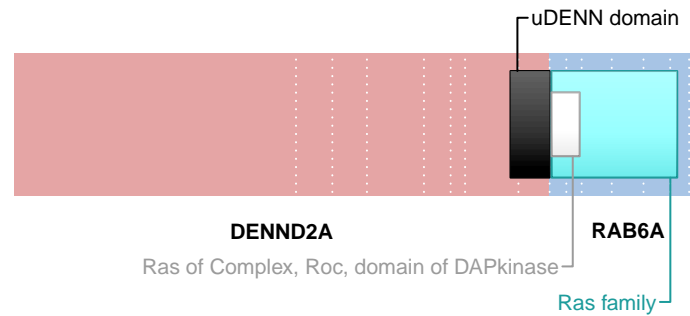

**SUPPORTING READ COUNT**

Split reads = 38  
Discordant mates = 0

- translocation
- duplication
- deletion
- inversion

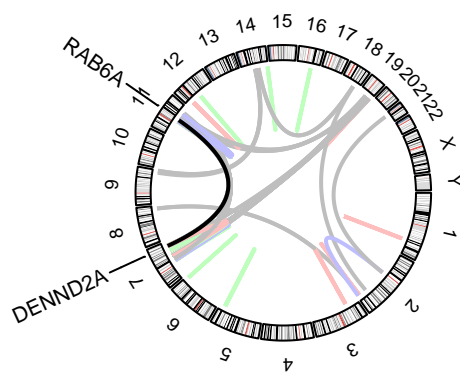
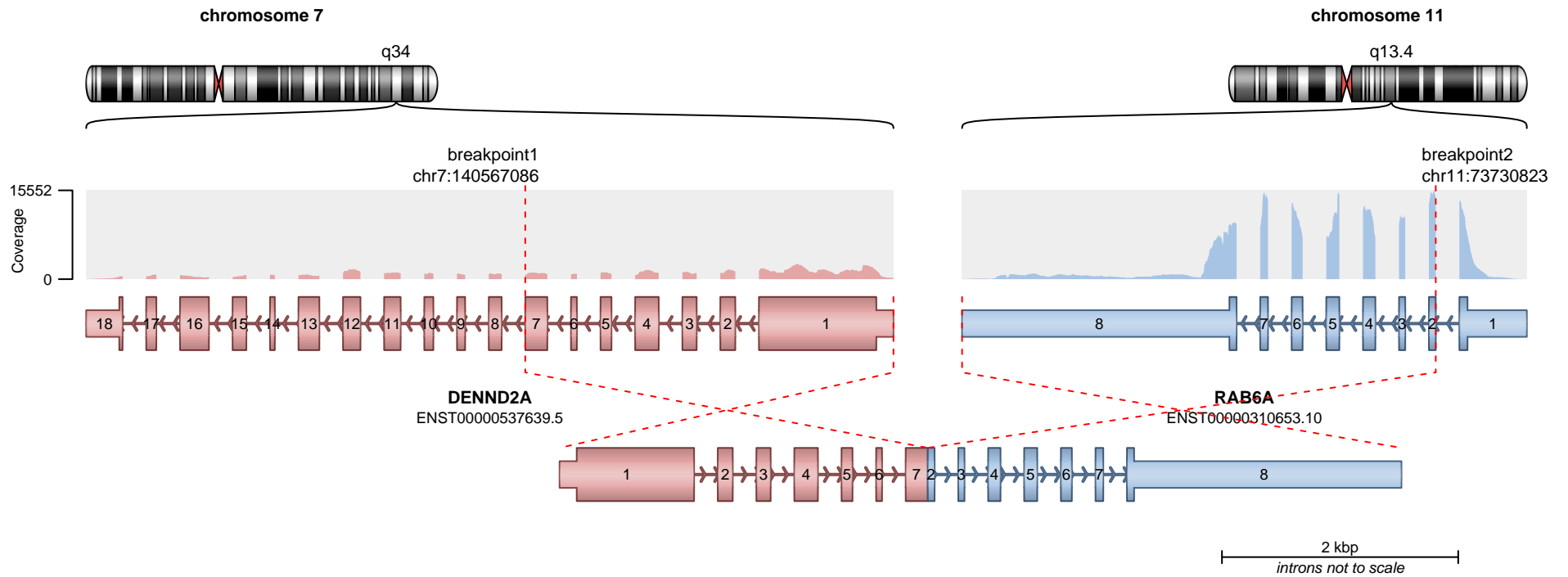

**RETAINED PROTEIN DOMAINS**  
reading frame unclear

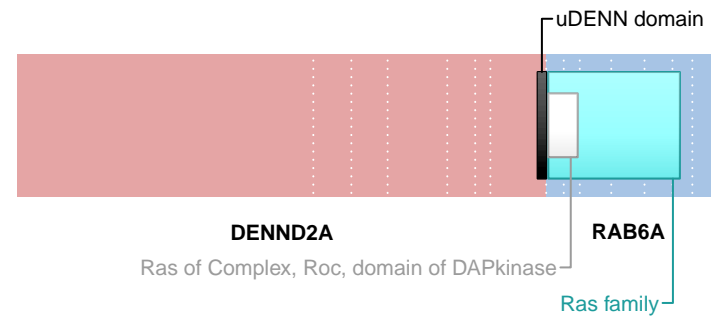

**SUPPORTING READ COUNT**

Split reads = 2  
Discordant mates = 0

- translocation
- duplication
- deletion
- inversion

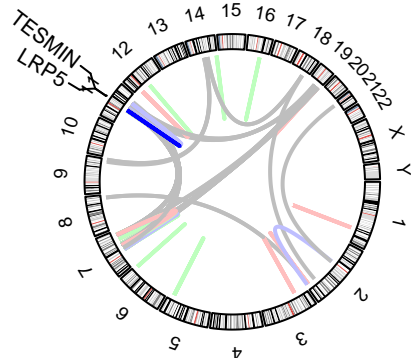
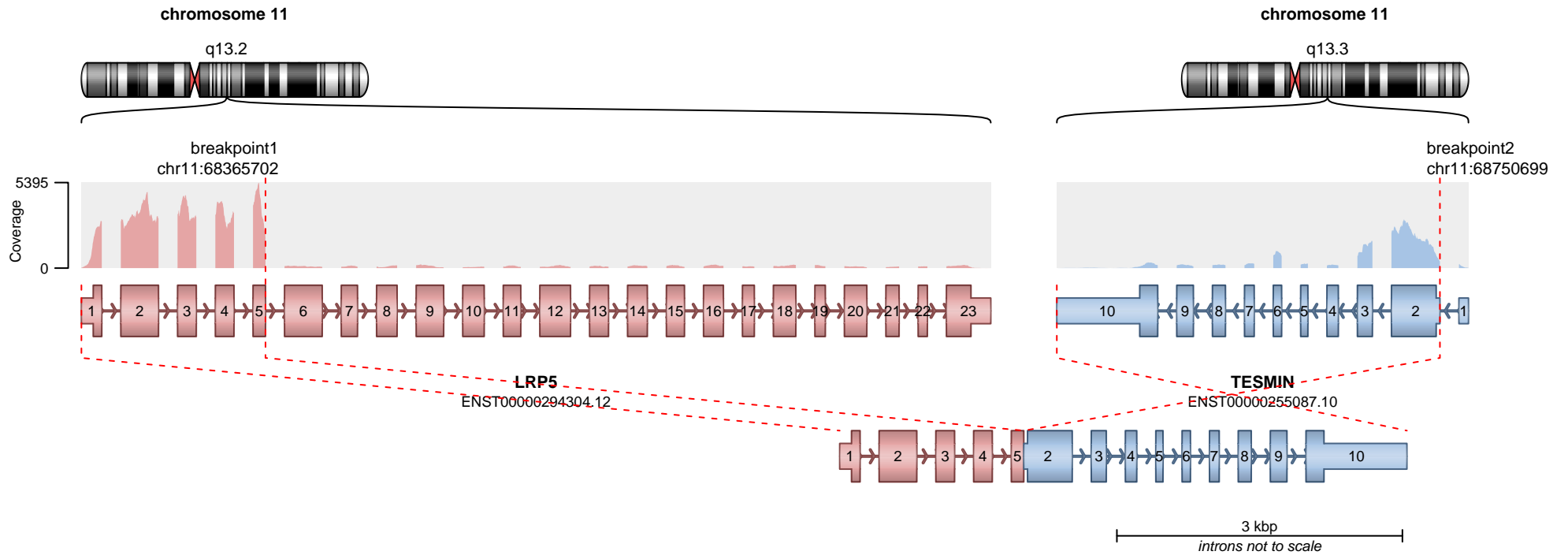

— translocation    — deletion  
— duplication    — inversion

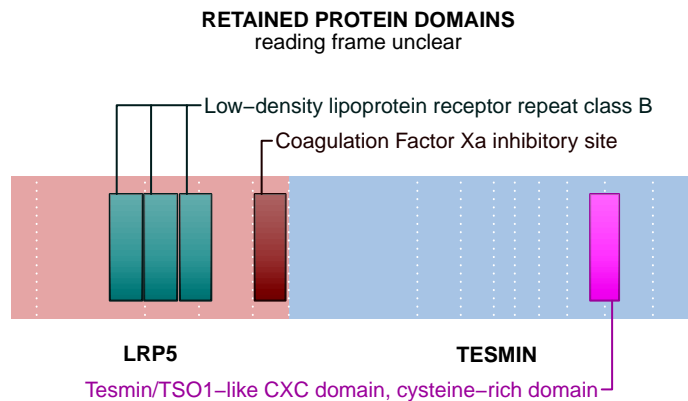

**SUPPORTING READ COUNT**

Split reads = 35  
Discordant mates = 0

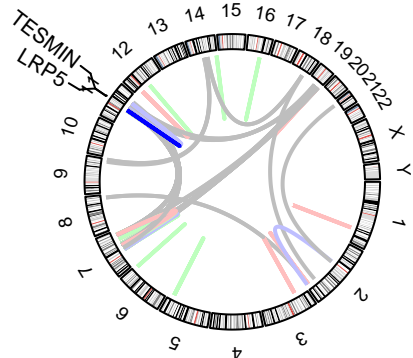
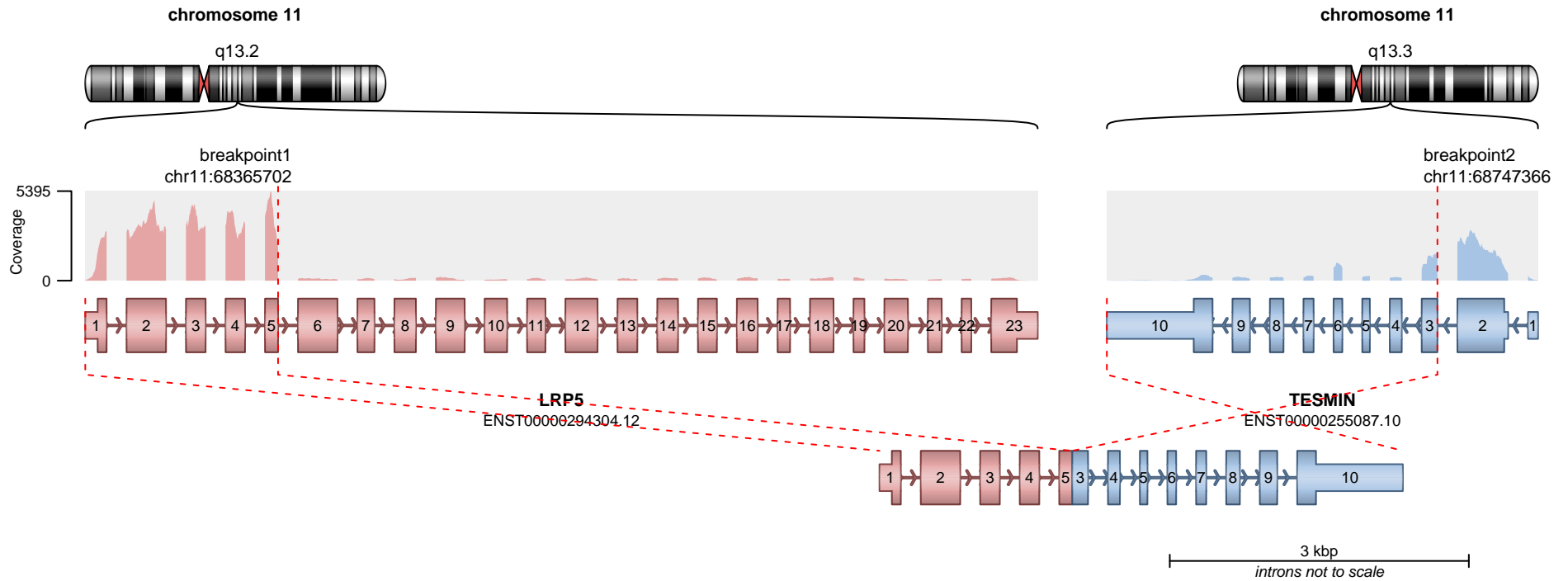

**RETAINED PROTEIN DOMAINS**  
reading frame unclear

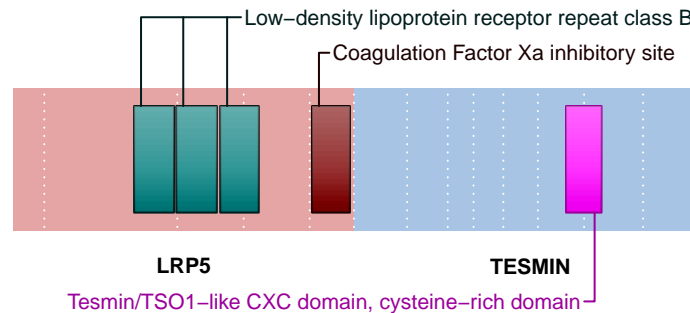

**SUPPORTING READ COUNT**

Split reads = 15  
Discordant mates = 0

— translocation — deletion  
— duplication — inversion

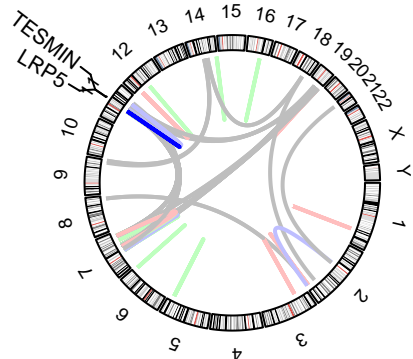
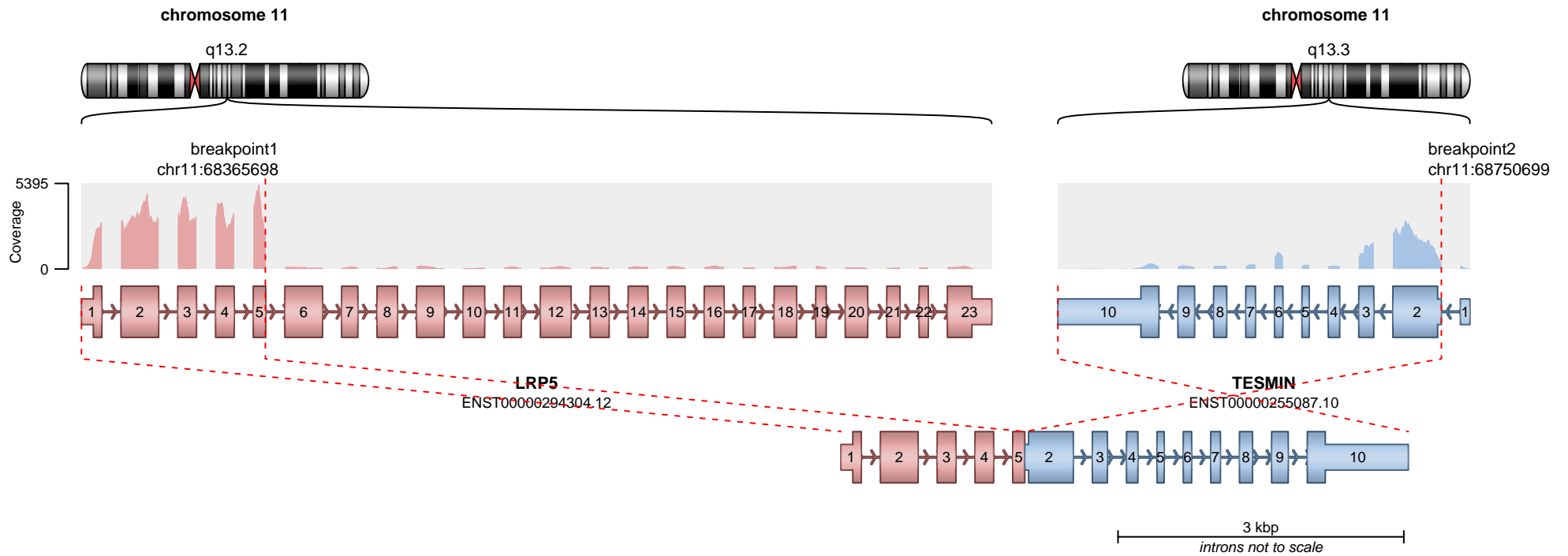

**RETAINED PROTEIN DOMAINS**  
reading frame unclear

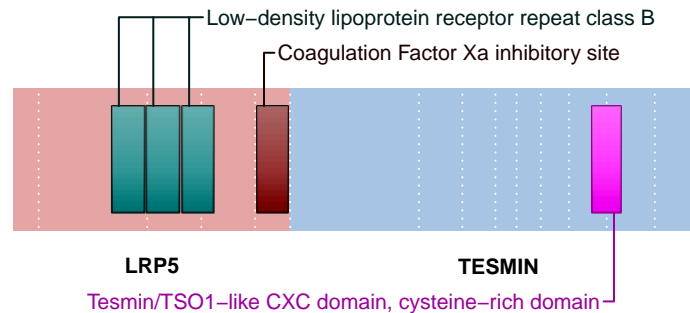

**SUPPORTING READ COUNT**

Split reads = 5  
Discordant mates = 0

— translocation — deletion  
— duplication — inversion

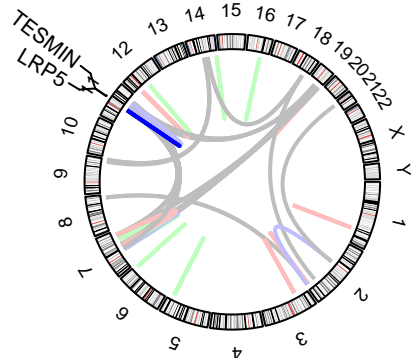
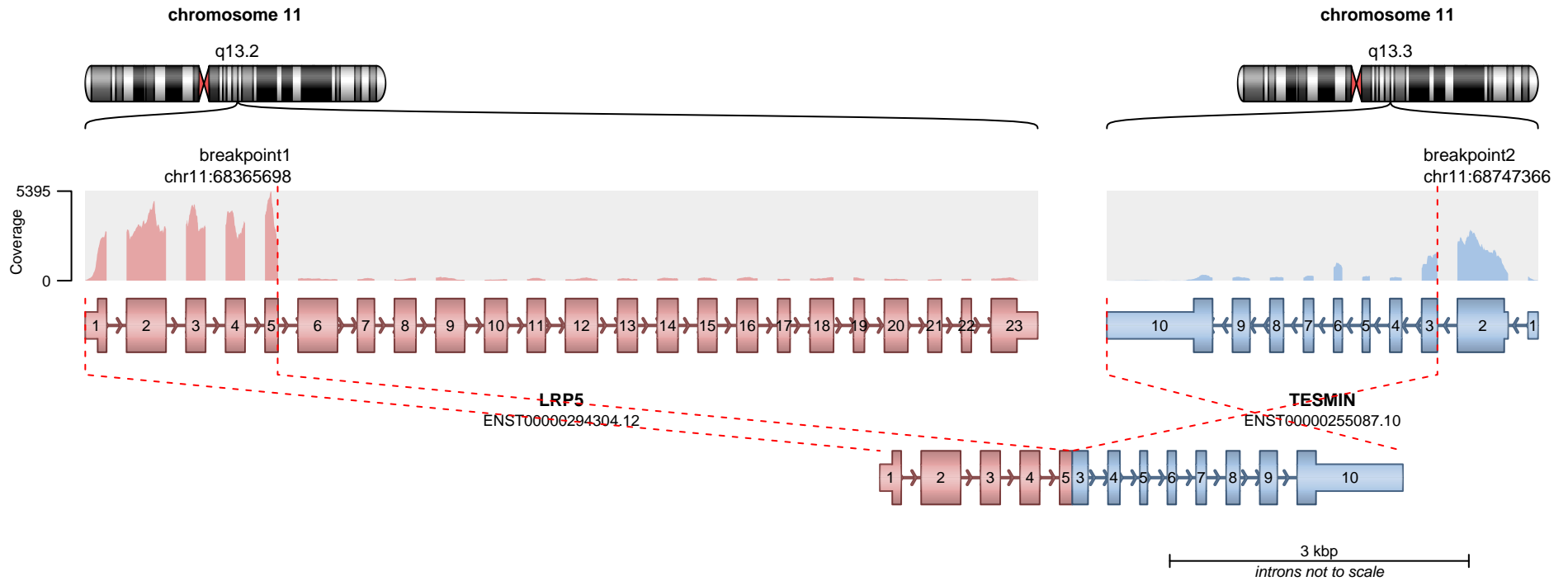

**RETAINED PROTEIN DOMAINS**  
reading frame unclear

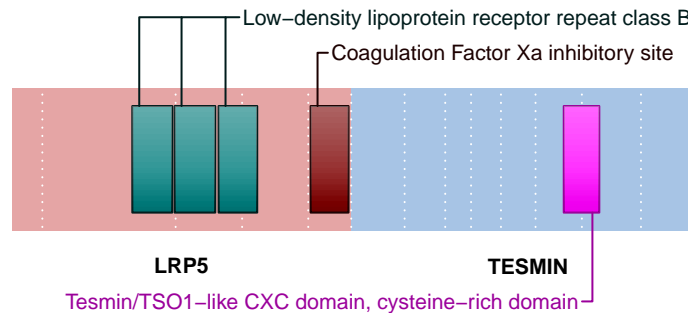

**SUPPORTING READ COUNT**

Split reads = 3  
Discordant mates = 0

— translocation — deletion  
— duplication — inversion

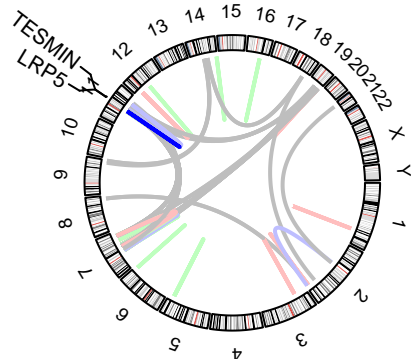
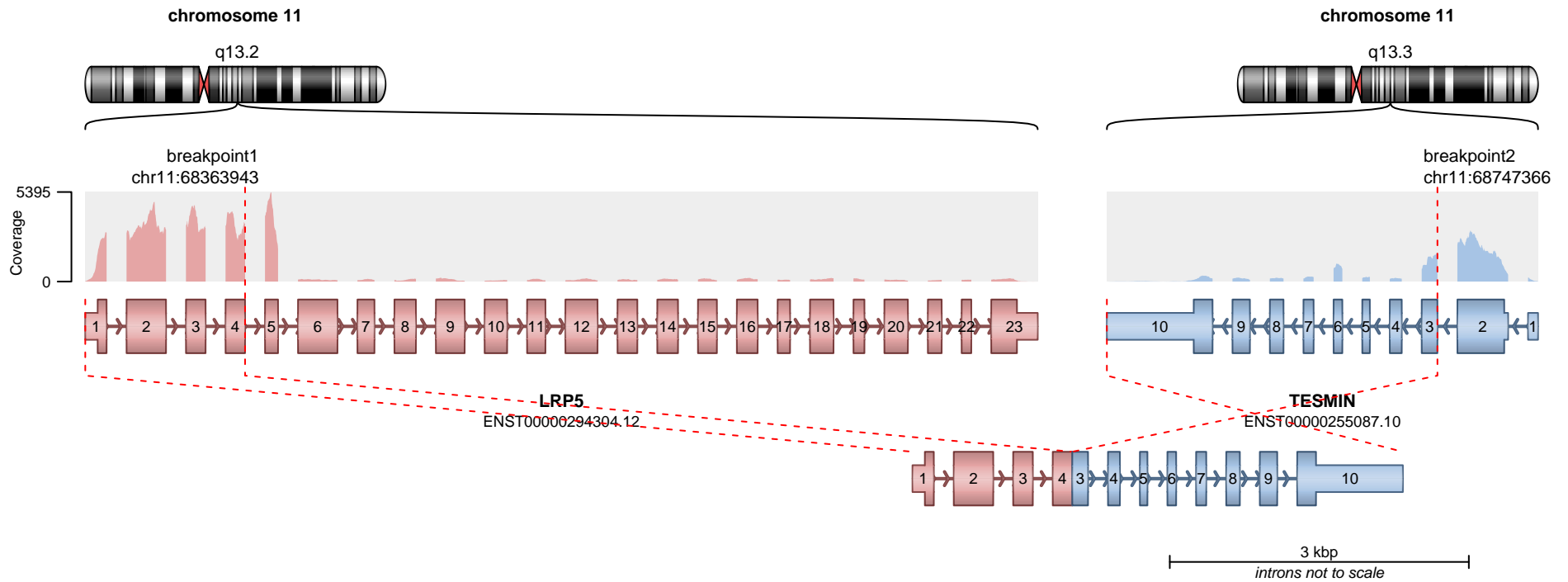

**RETAINED PROTEIN DOMAINS**  
reading frame unclear

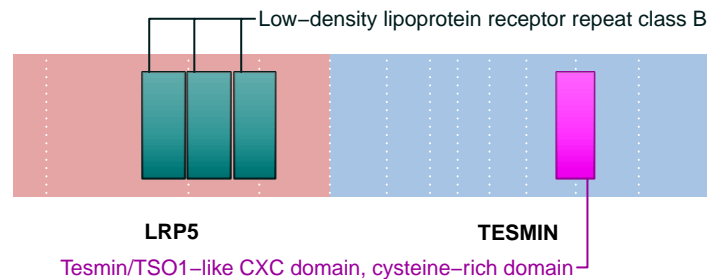

**SUPPORTING READ COUNT**

Split reads = 1  
Discordant mates = 0

— translocation — deletion  
— duplication — inversion

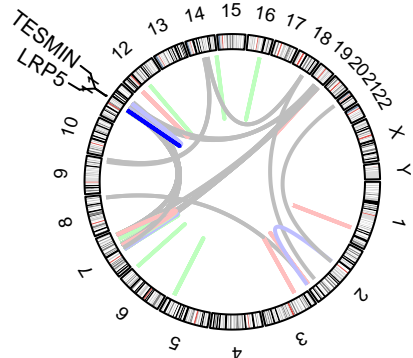
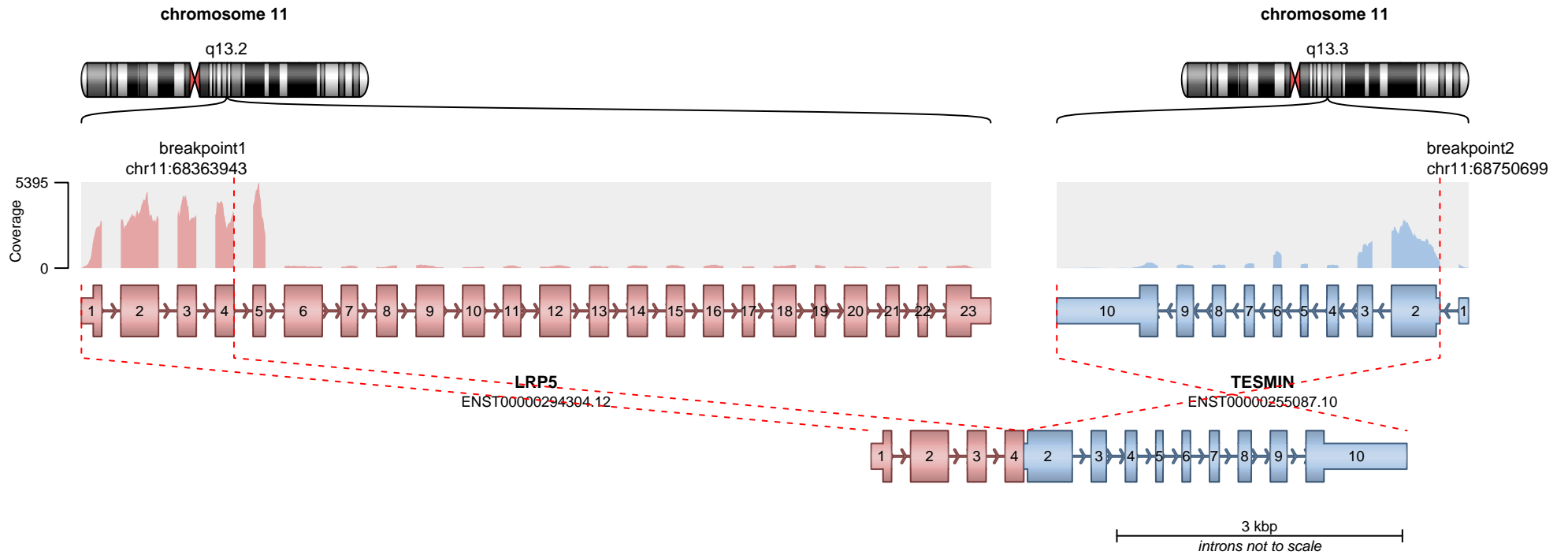

**RETAINED PROTEIN DOMAINS**  
reading frame unclear

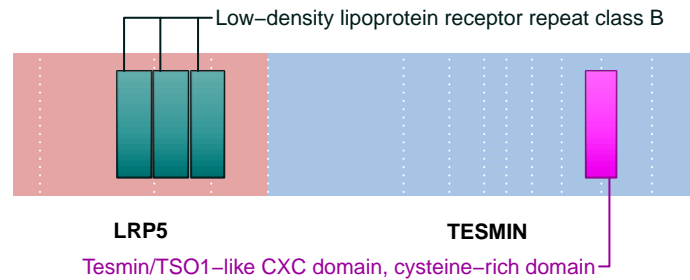

**SUPPORTING READ COUNT**

Split reads = 1  
Discordant mates = 0

— translocation — deletion  
— duplication — inversion

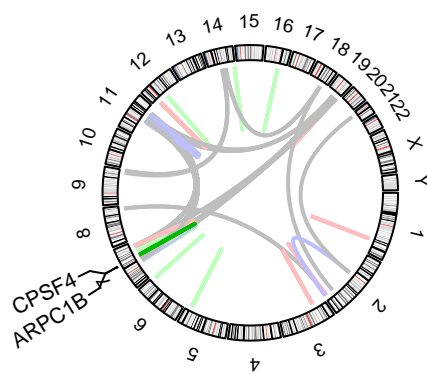
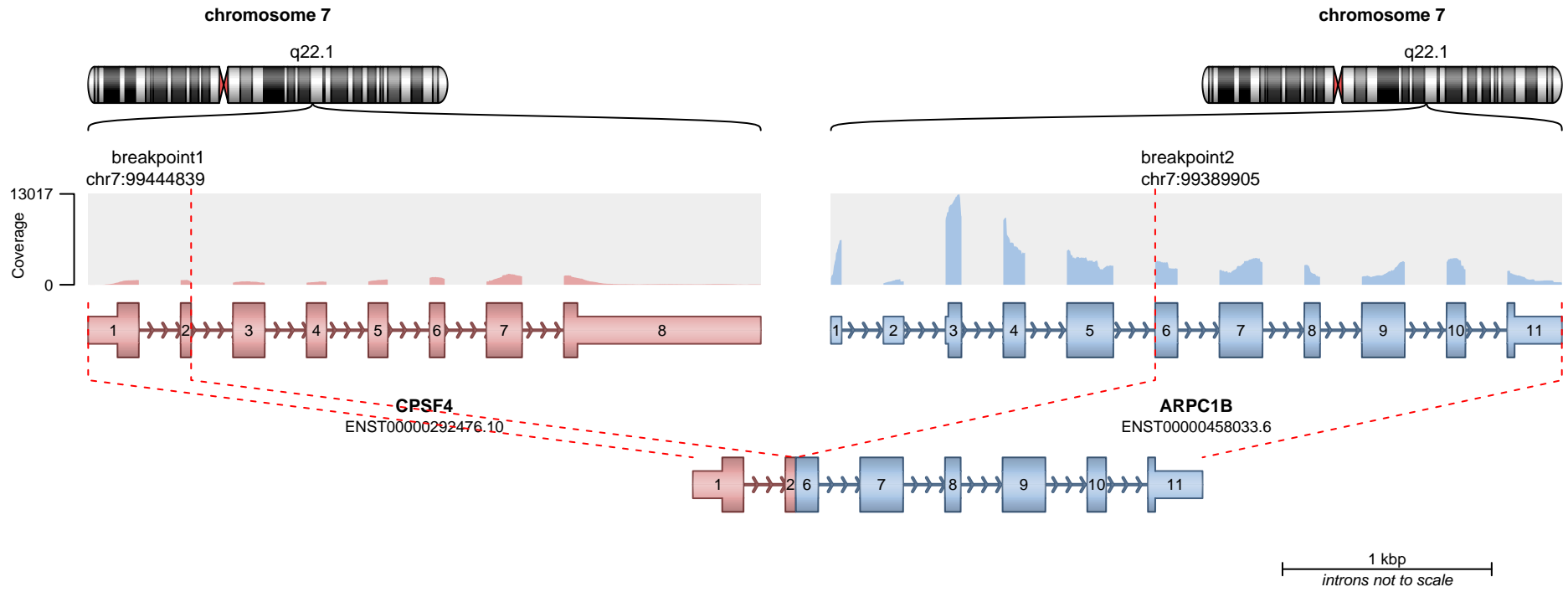

**RETAINED PROTEIN DOMAINS**  
reading frame unclear

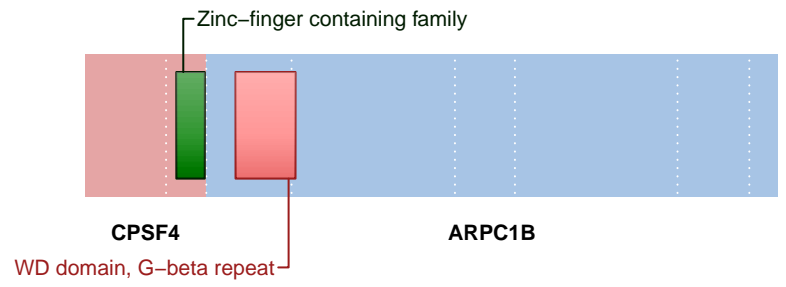

**SUPPORTING READ COUNT**

Split reads = 33  
Discordant mates = 0

- translocation
- duplication
- deletion
- inversion

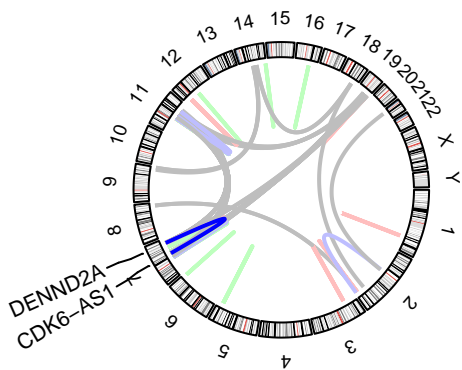
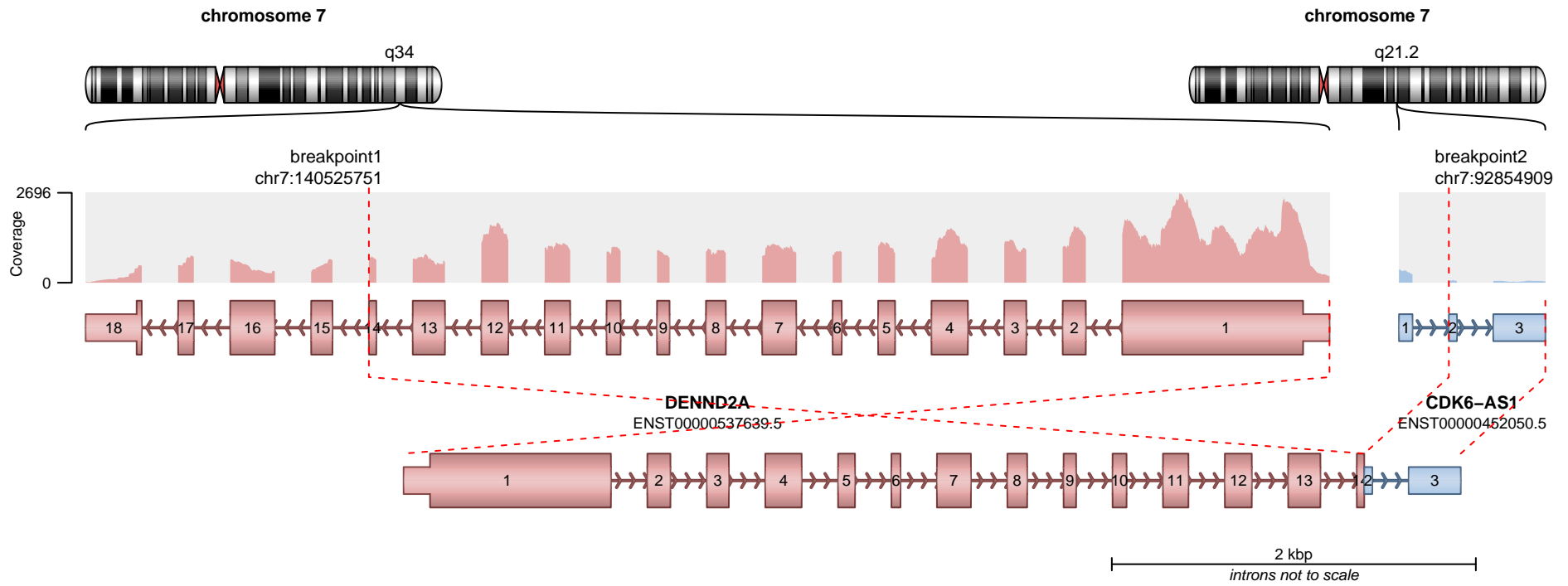

**RETAINED PROTEIN DOMAINS**  
reading frame unclear

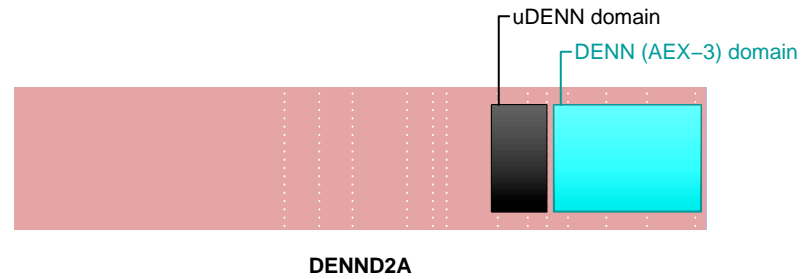

**SUPPORTING READ COUNT**

Split reads = 33  
Discordant mates = 0

— translocation    — deletion  
— duplication    — inversion

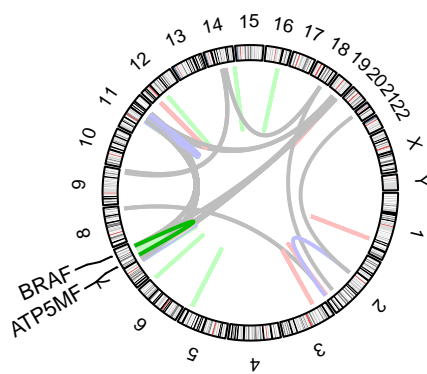
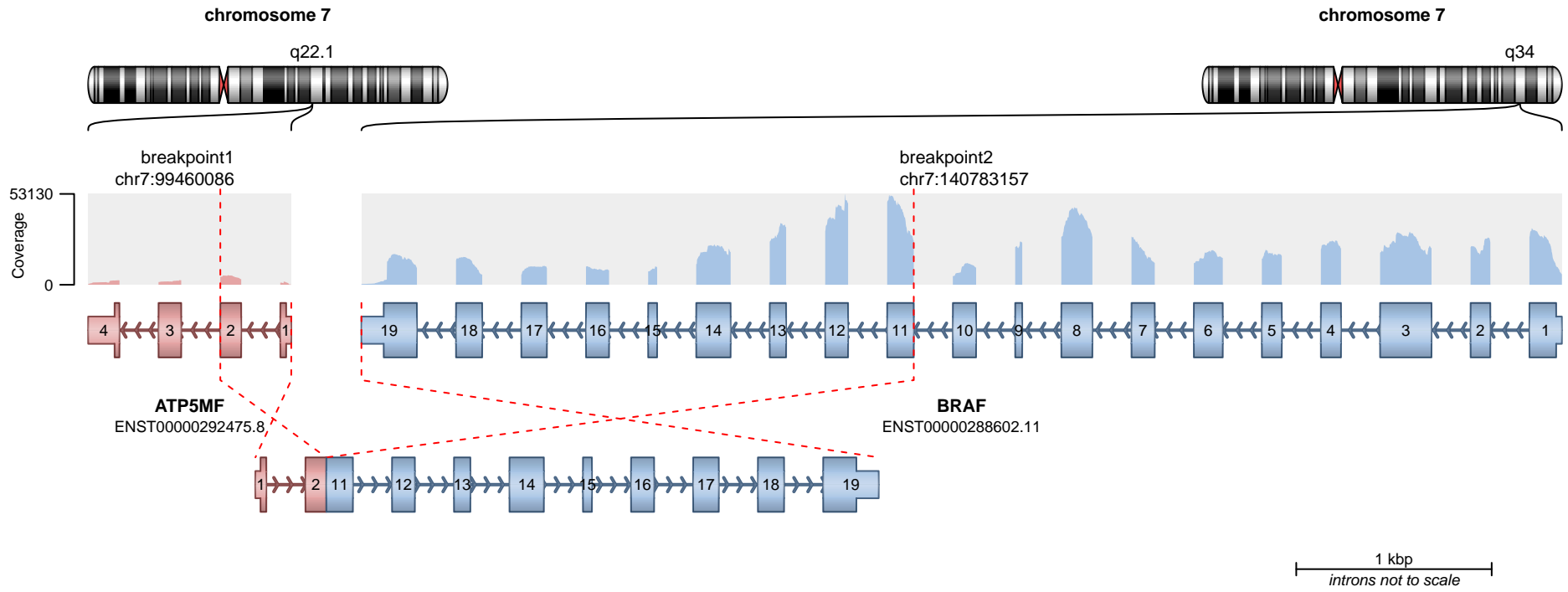

**RETAINED PROTEIN DOMAINS**  
reading frame unclear

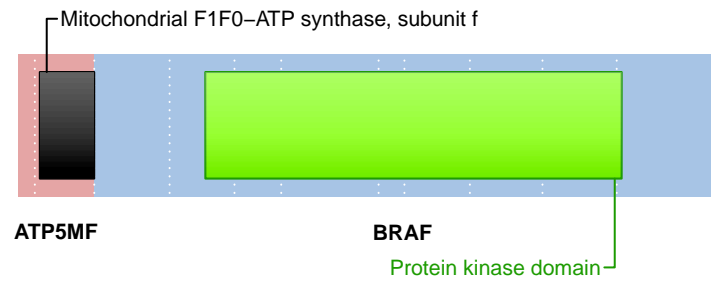

**SUPPORTING READ COUNT**

Split reads = 31  
Discordant mates = 0

- translocation
- duplication
- deletion
- inversion

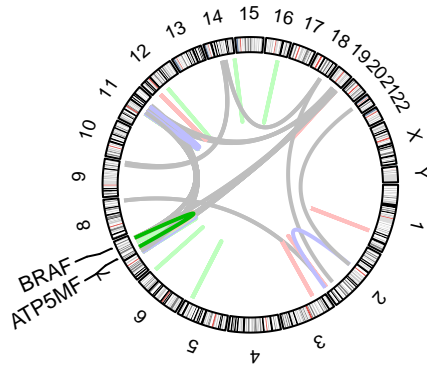
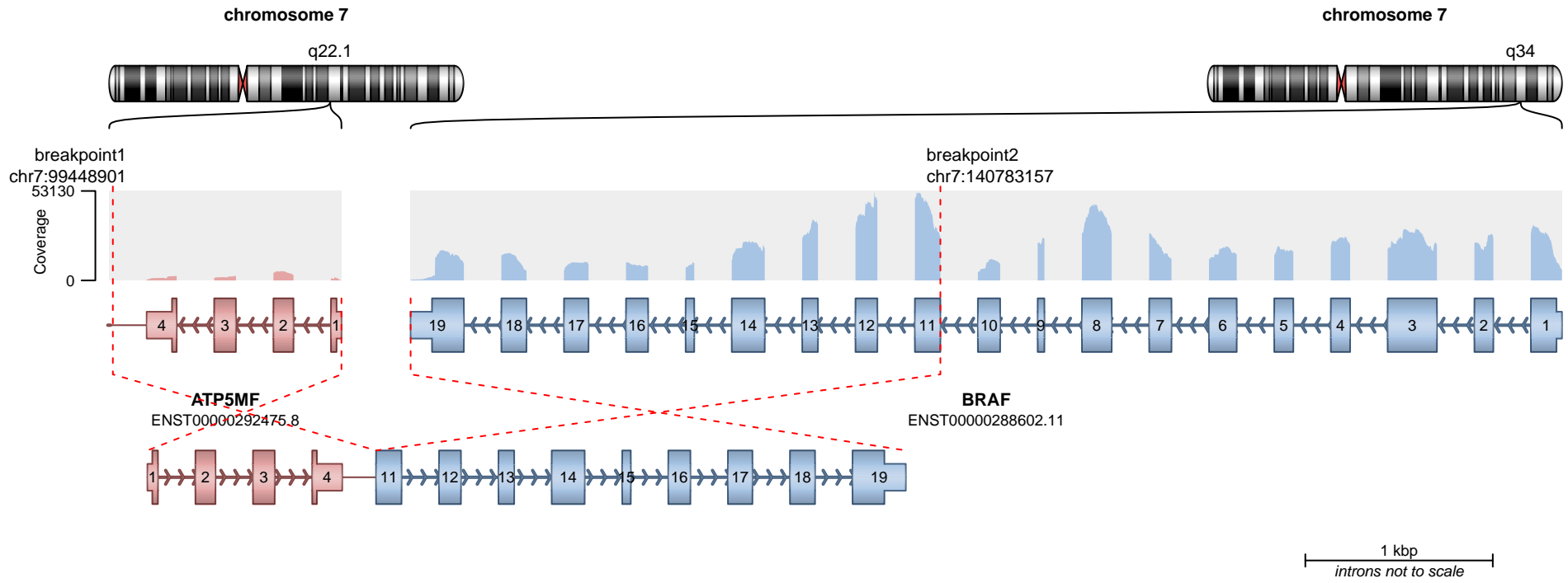

**RETAINED PROTEIN DOMAINS**  
reading frame unclear

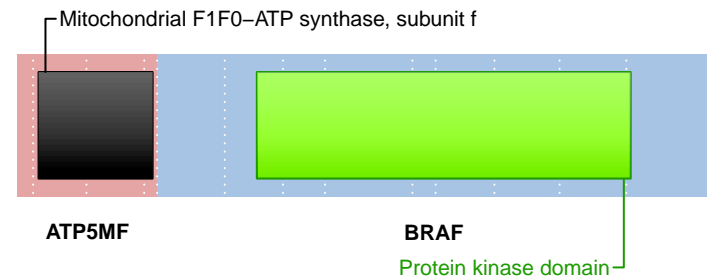

**SUPPORTING READ COUNT**

Split reads = 11  
Discordant mates = 0

- translocation
- duplication
- deletion
- inversion

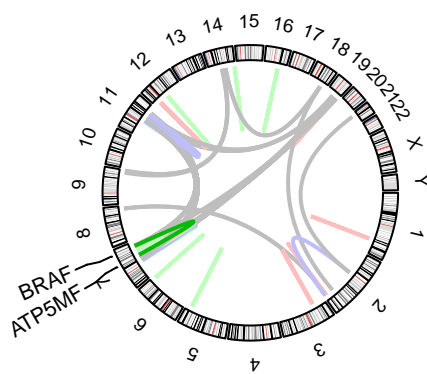
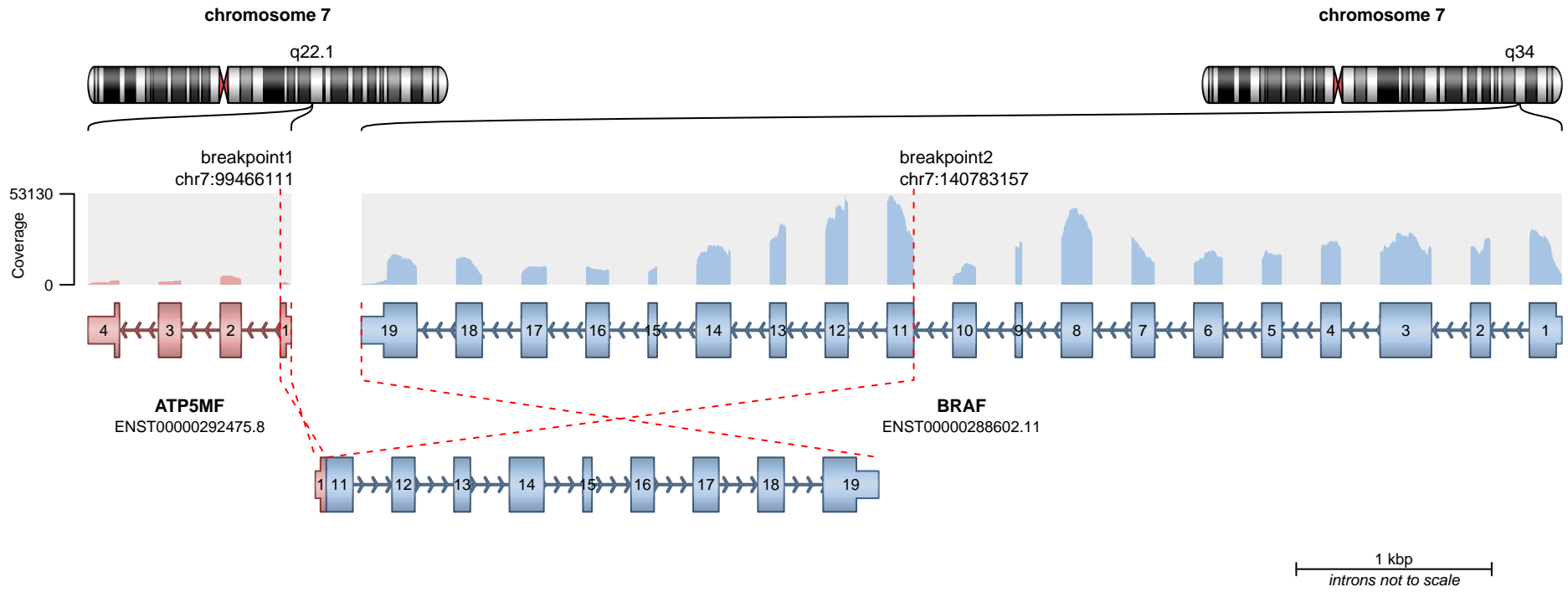

— translocation    — deletion  
— duplication    — inversion

**RETAINED PROTEIN DOMAINS**  
reading frame unclear

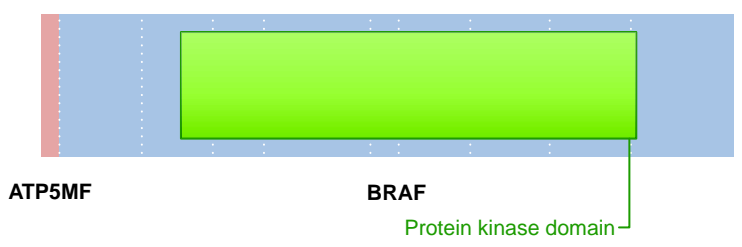

**SUPPORTING READ COUNT**

Split reads = 7  
Discordant mates = 0

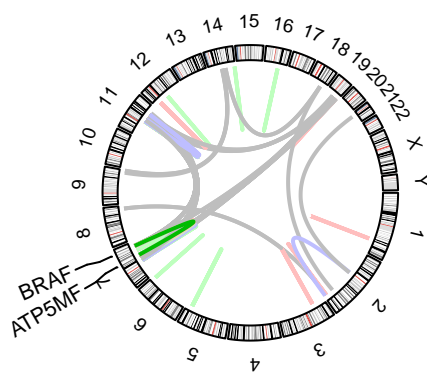
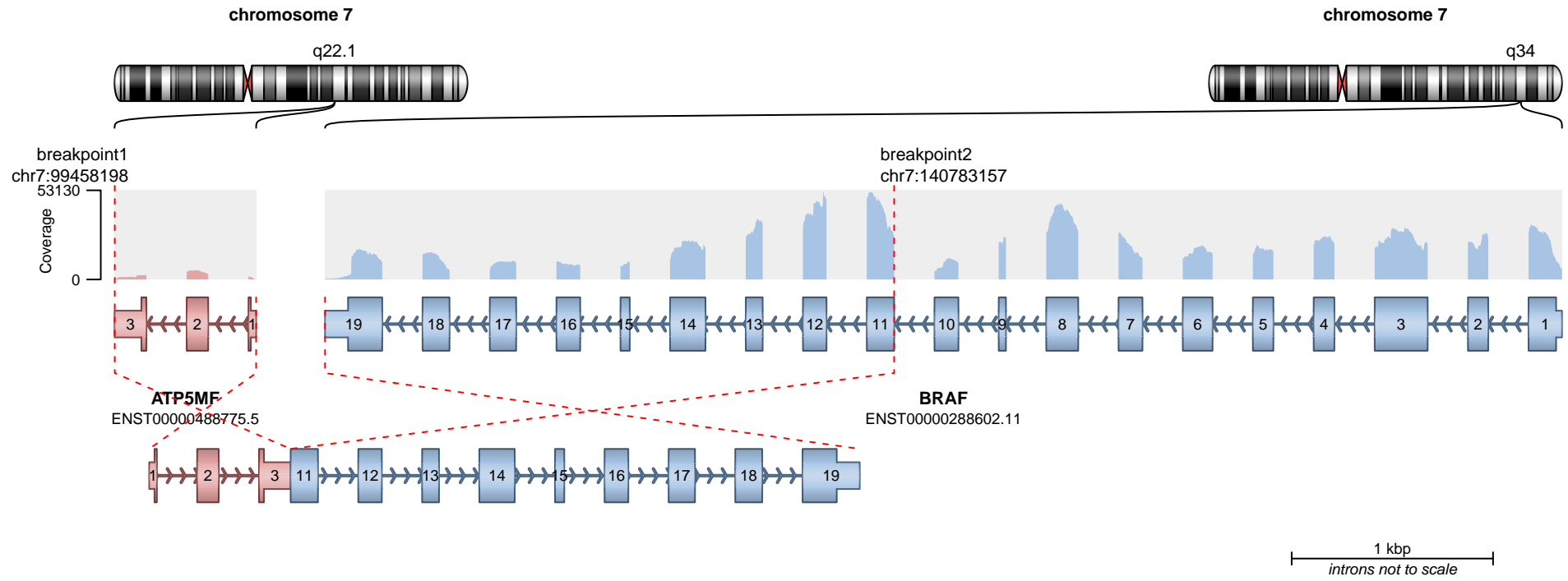

**RETAINED PROTEIN DOMAINS**  
reading frame unclear

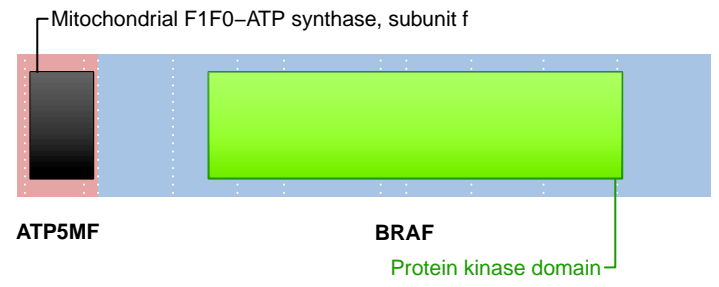

**SUPPORTING READ COUNT**

Split reads = 7  
Discordant mates = 0

- translocation
- duplication
- deletion
- inversion

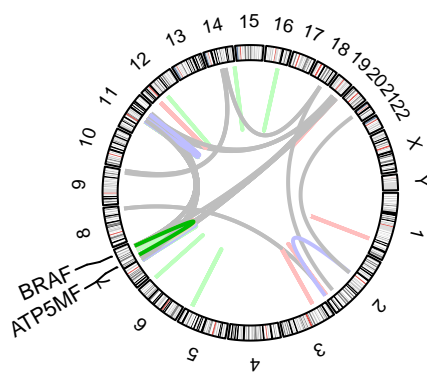
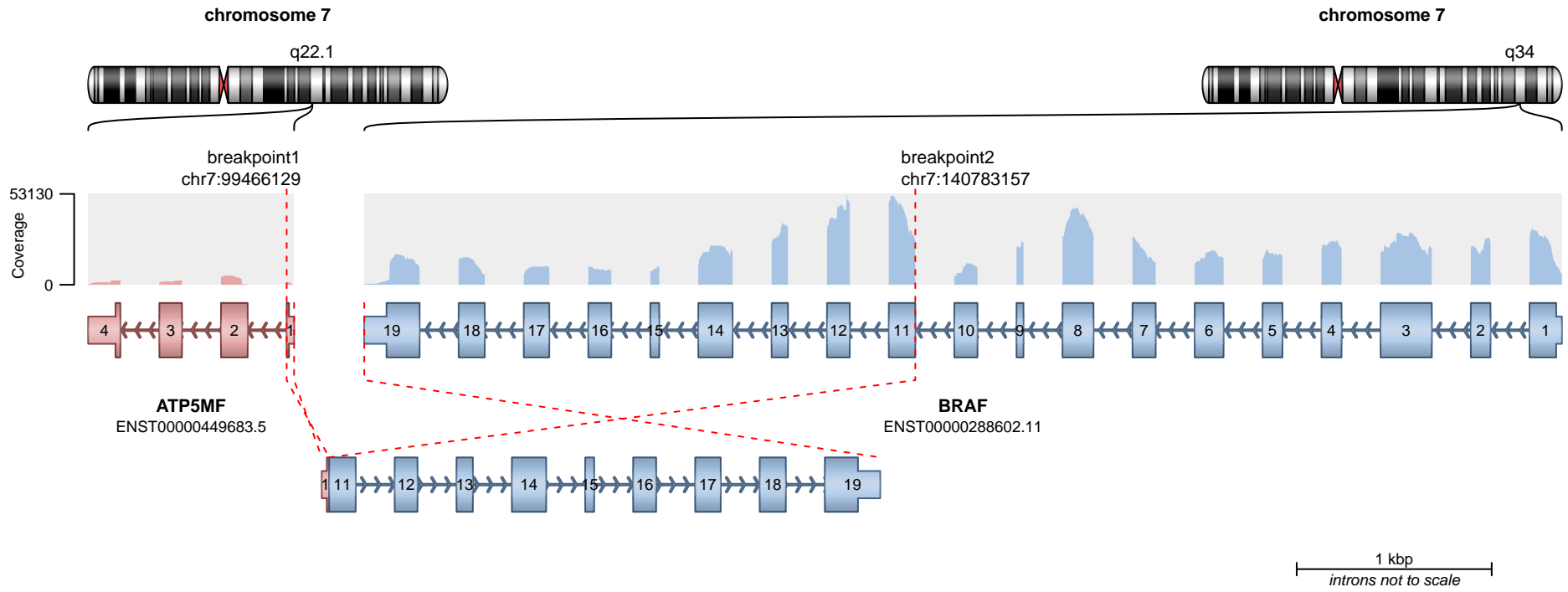

— translocation    — deletion  
 — duplication    — inversion

**RETAINED PROTEIN DOMAINS**  
reading frame unclear

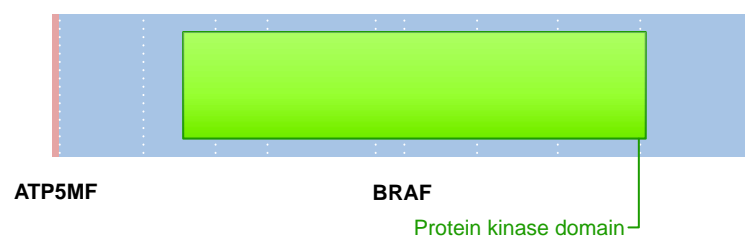

**SUPPORTING READ COUNT**

Split reads = 6  
Discordant mates = 0

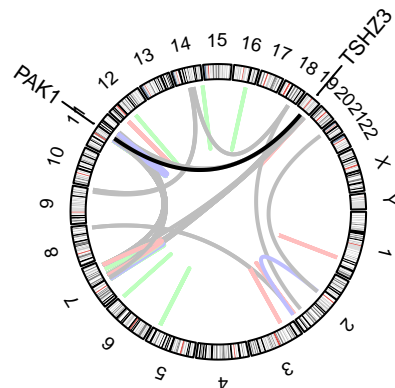
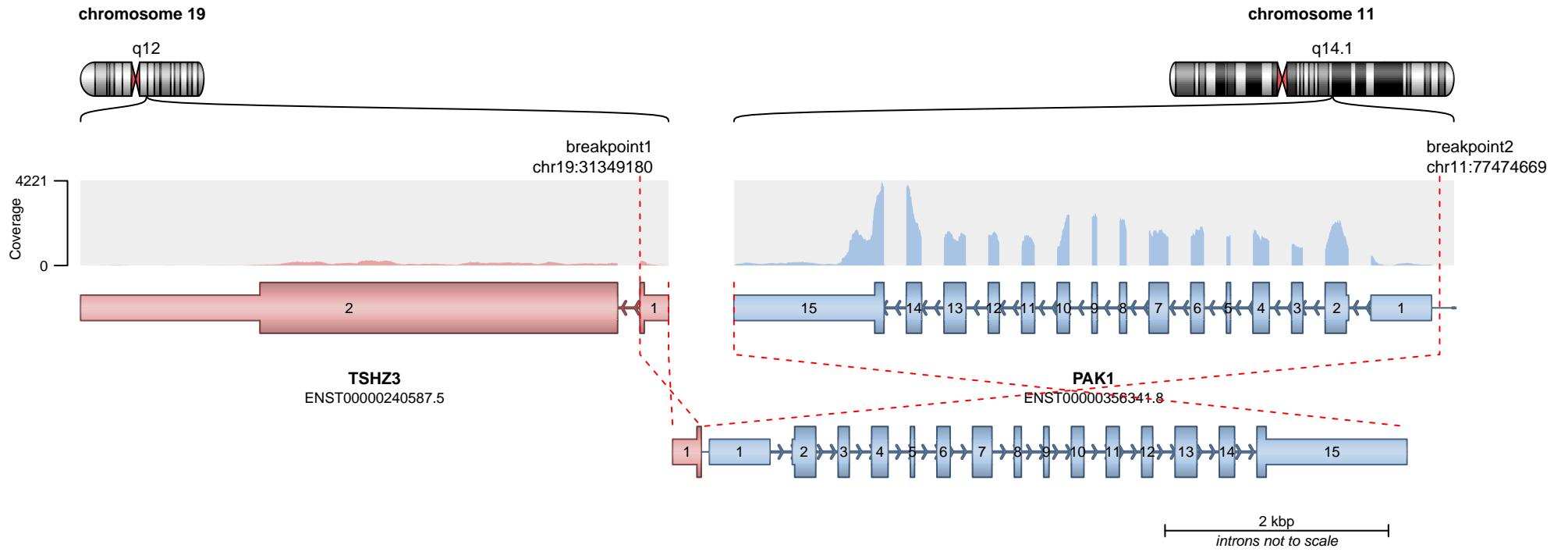

**RETAINED PROTEIN DOMAINS**  
reading frame unclear

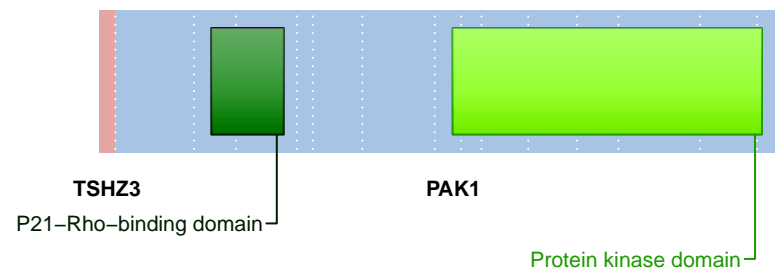

**SUPPORTING READ COUNT**

Split reads = 31  
Discordant mates = 0

- translocation
- duplication
- deletion
- inversion

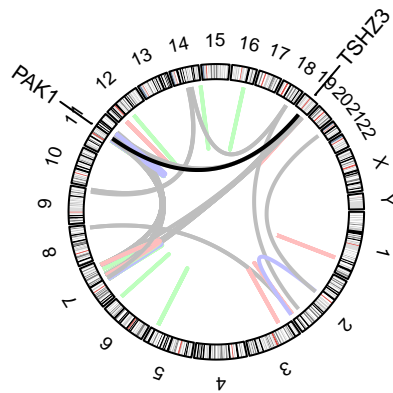
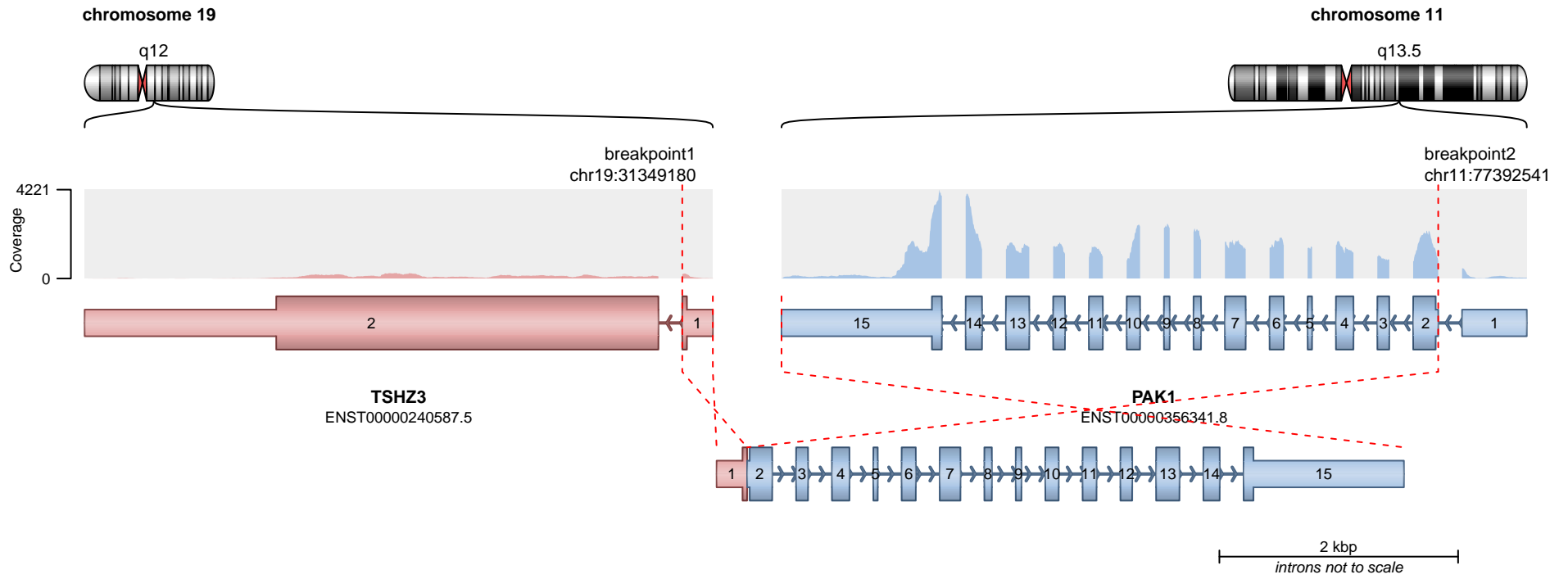

**RETAINED PROTEIN DOMAINS**  
reading frame unclear

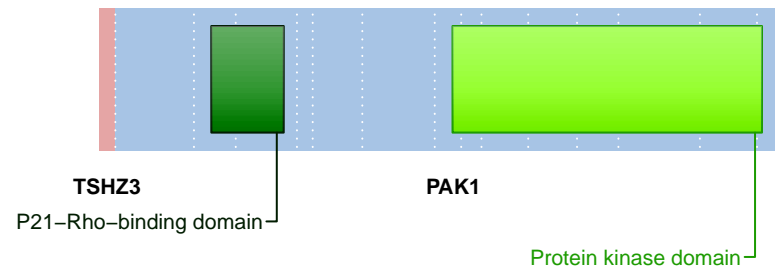

**SUPPORTING READ COUNT**

Split reads = 3  
Discordant mates = 0

- translocation
- duplication
- deletion
- inversion

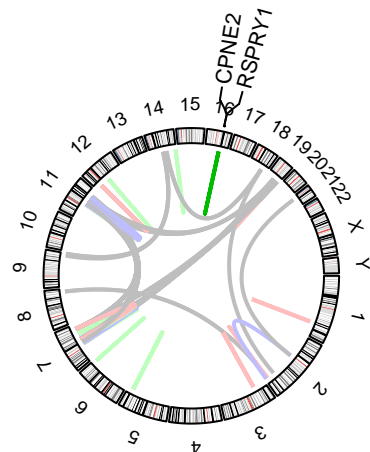
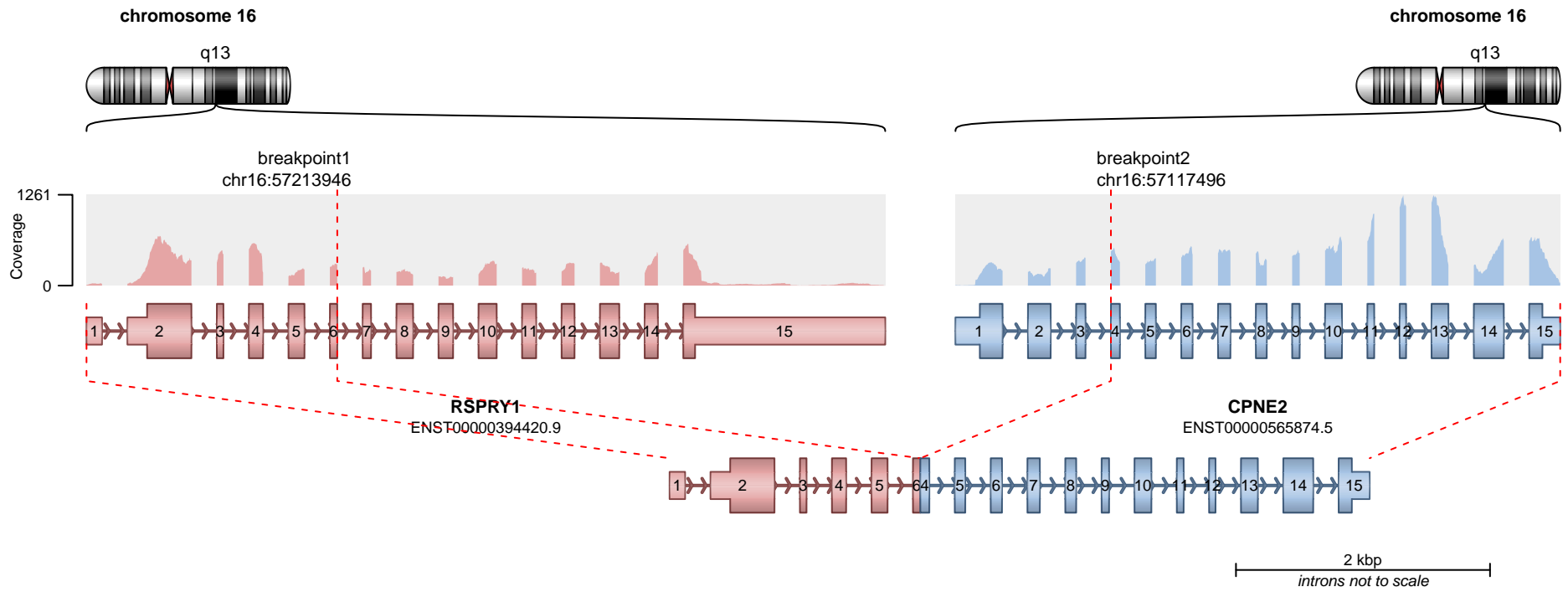

**RETAINED PROTEIN DOMAINS**  
reading frame unclear

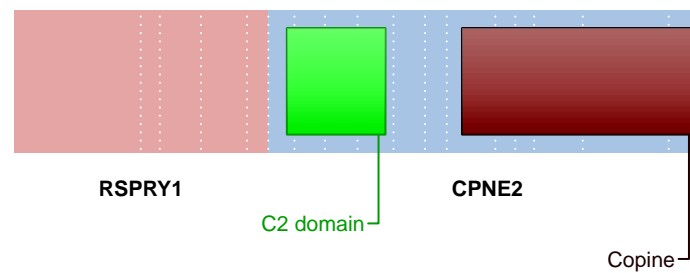

**SUPPORTING READ COUNT**

Split reads = 30  
Discordant mates = 0

- translocation
- duplication
- deletion
- inversion

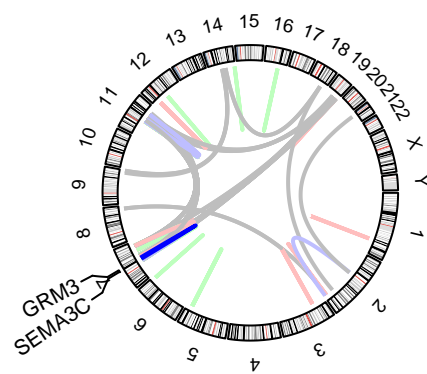
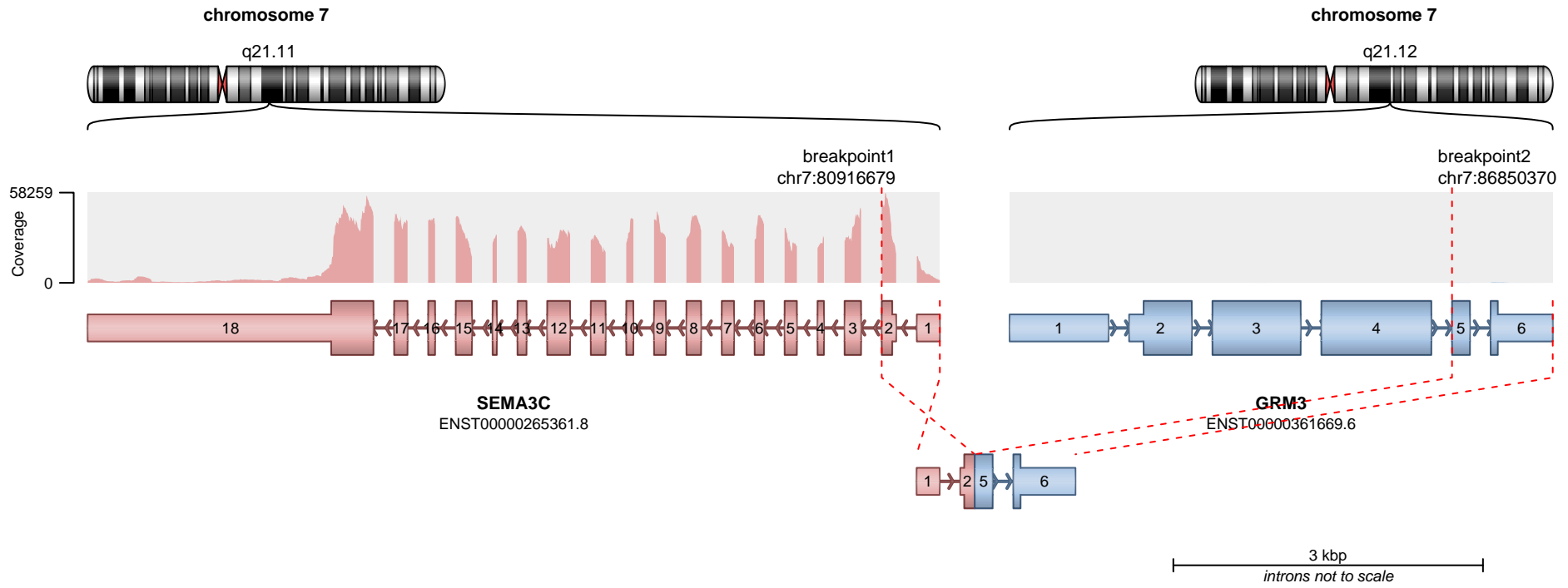

**RETAINED PROTEIN DOMAINS**  
reading frame unclear

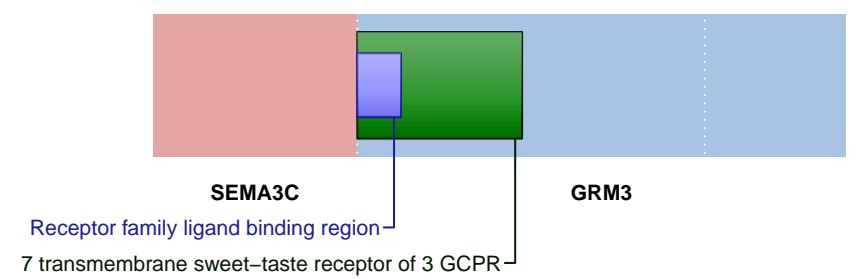

**SUPPORTING READ COUNT**

Split reads = 28  
Discordant mates = 0

- translocation
- duplication
- deletion
- inversion

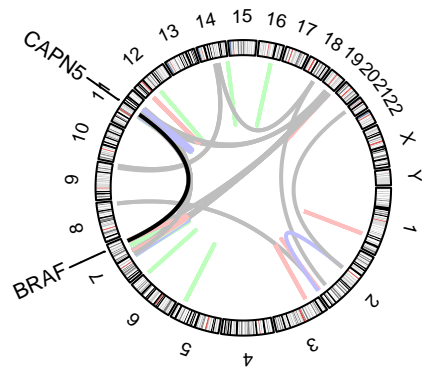
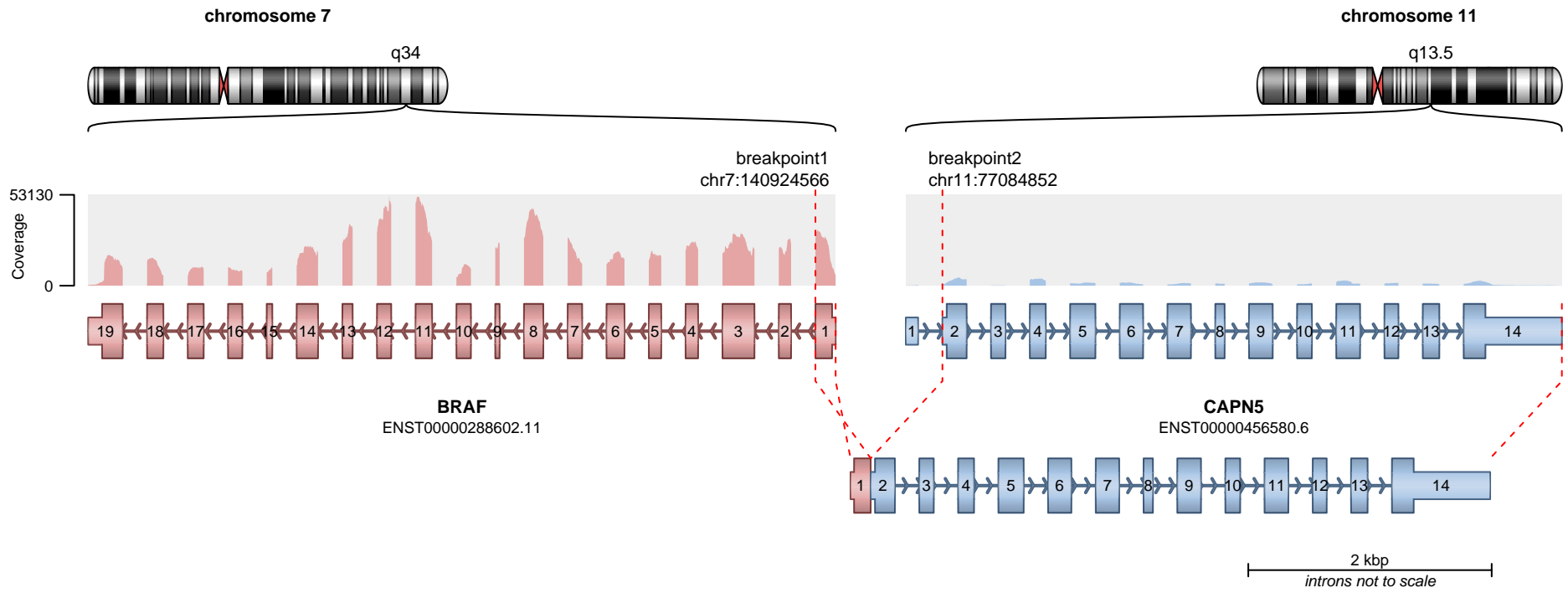

**RETAINED PROTEIN DOMAINS**  
reading frame unclear

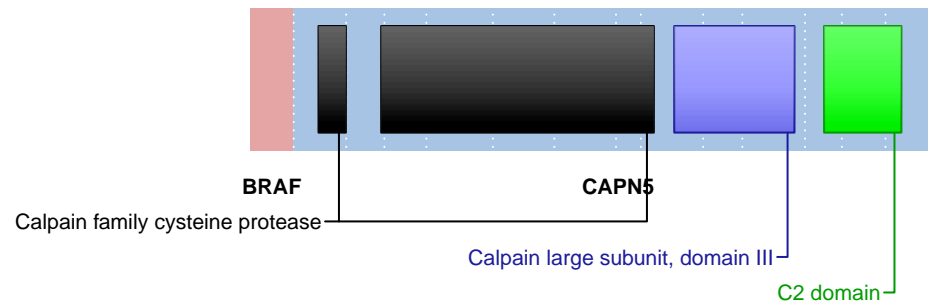

**SUPPORTING READ COUNT**

Split reads = 27  
Discordant mates = 0

— translocation    — deletion  
— duplication    — inversion

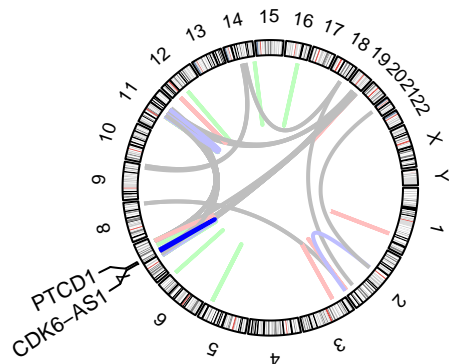
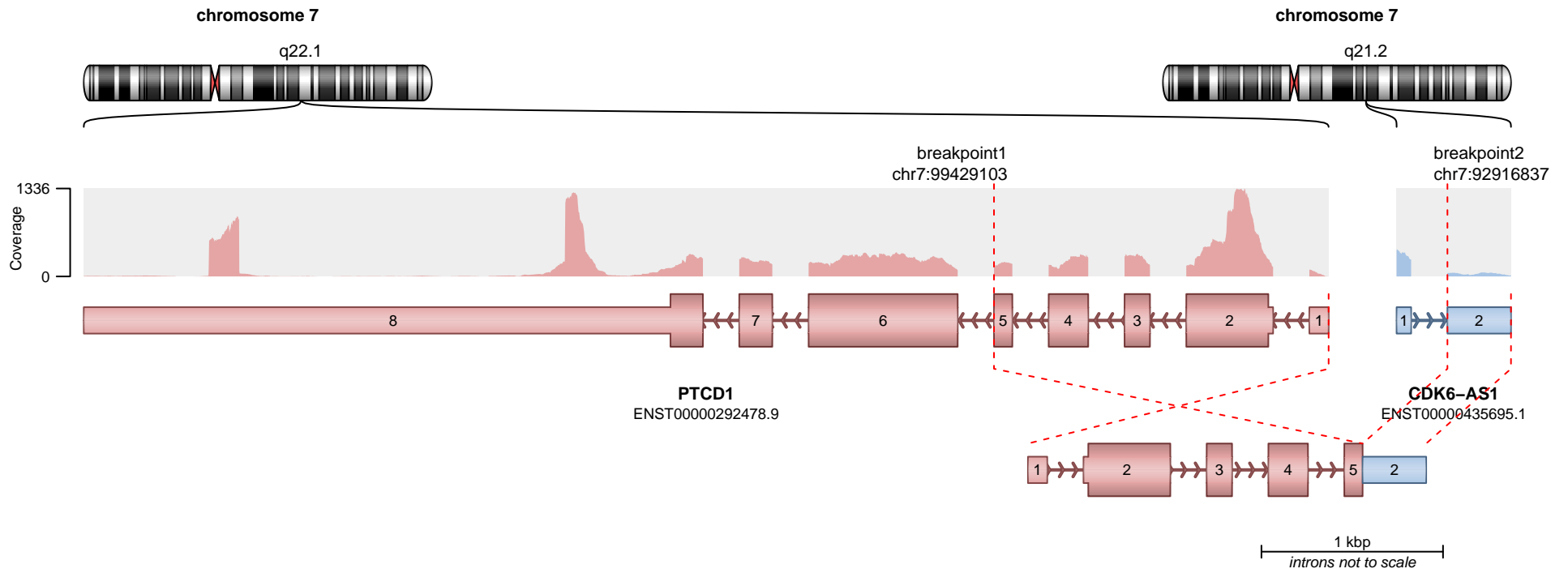

**RETAINED PROTEIN DOMAINS**  
reading frame unclear

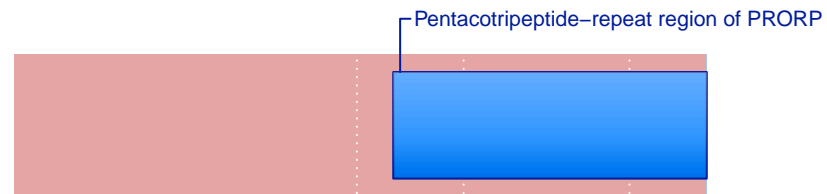

PTC1

**SUPPORTING READ COUNT**

Split reads = 25  
Discordant mates = 0

- translocation
- duplication
- deletion
- inversion

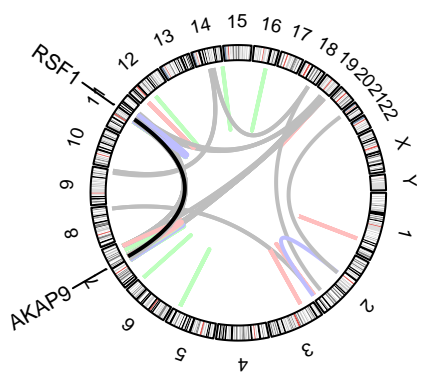
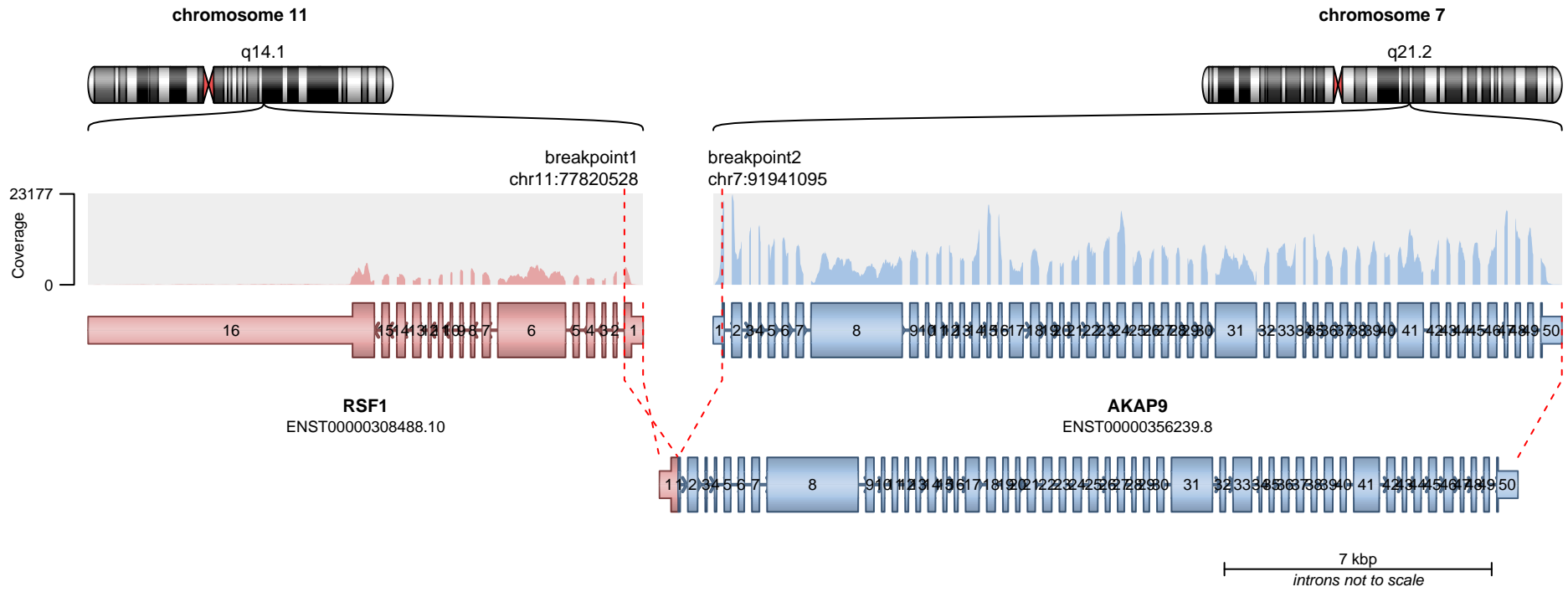

**RETAINED PROTEIN DOMAINS**  
reading frame unclear

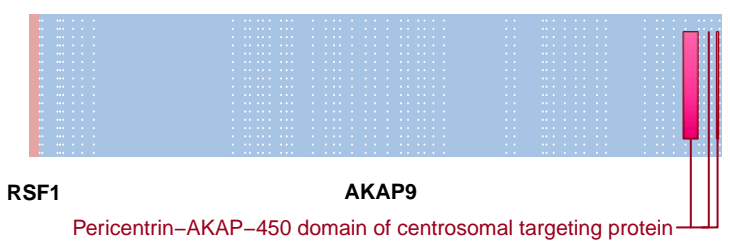

**SUPPORTING READ COUNT**

Split reads = 21  
Discordant mates = 0

— translocation — deletion  
— duplication — inversion

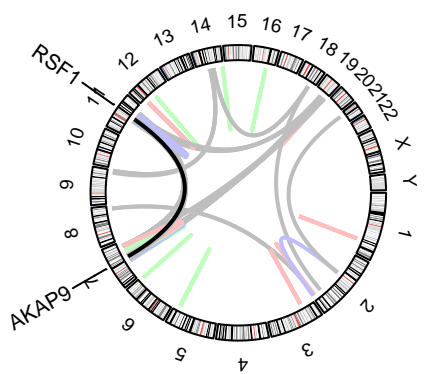
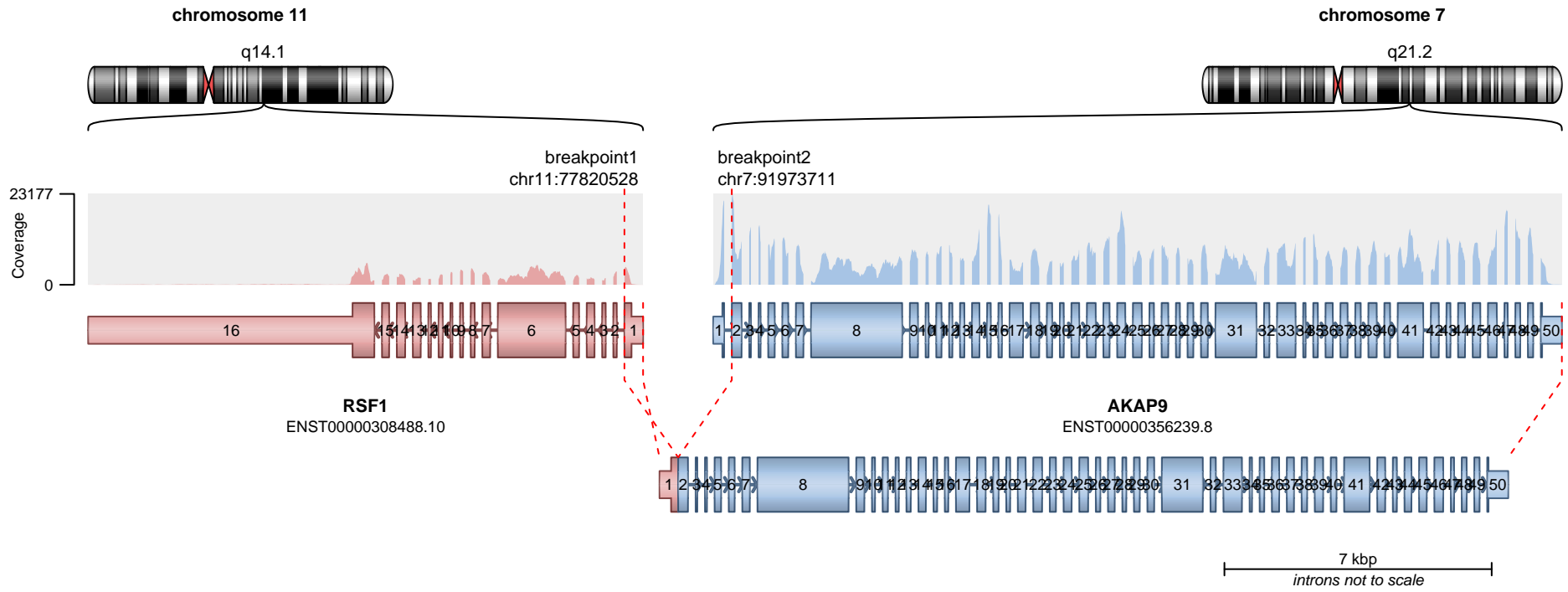

**RETAINED PROTEIN DOMAINS**  
reading frame unclear

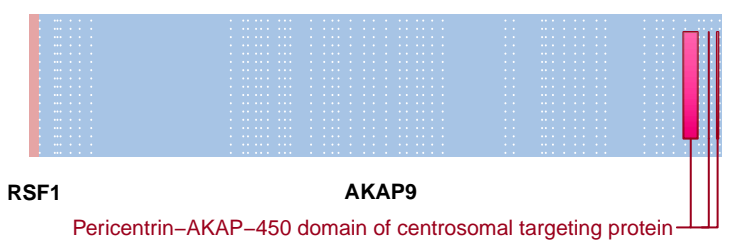

**SUPPORTING READ COUNT**

Split reads = 1  
Discordant mates = 0

- translocation
- duplication
- deletion
- inversion

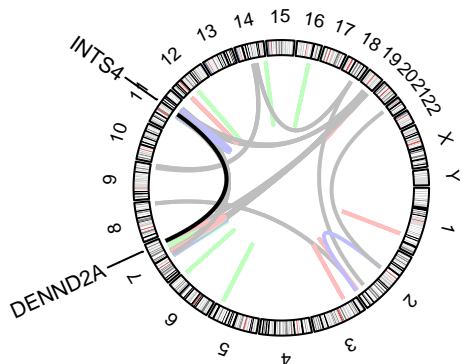
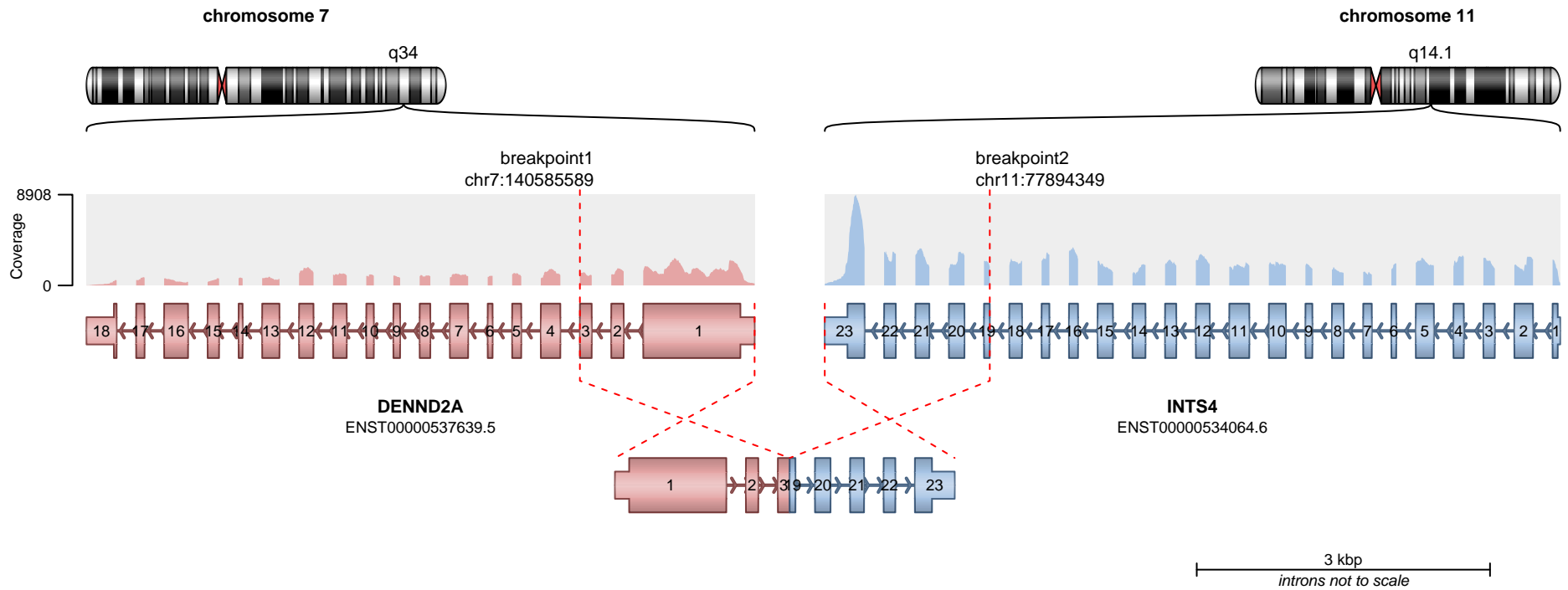

— translocation    — deletion  
 — duplication    — inversion

No protein domains retained in fusion.

**SUPPORTING READ COUNT**

Split reads = 19  
 Discordant mates = 0

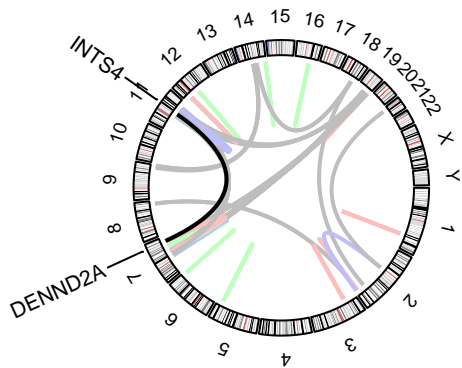
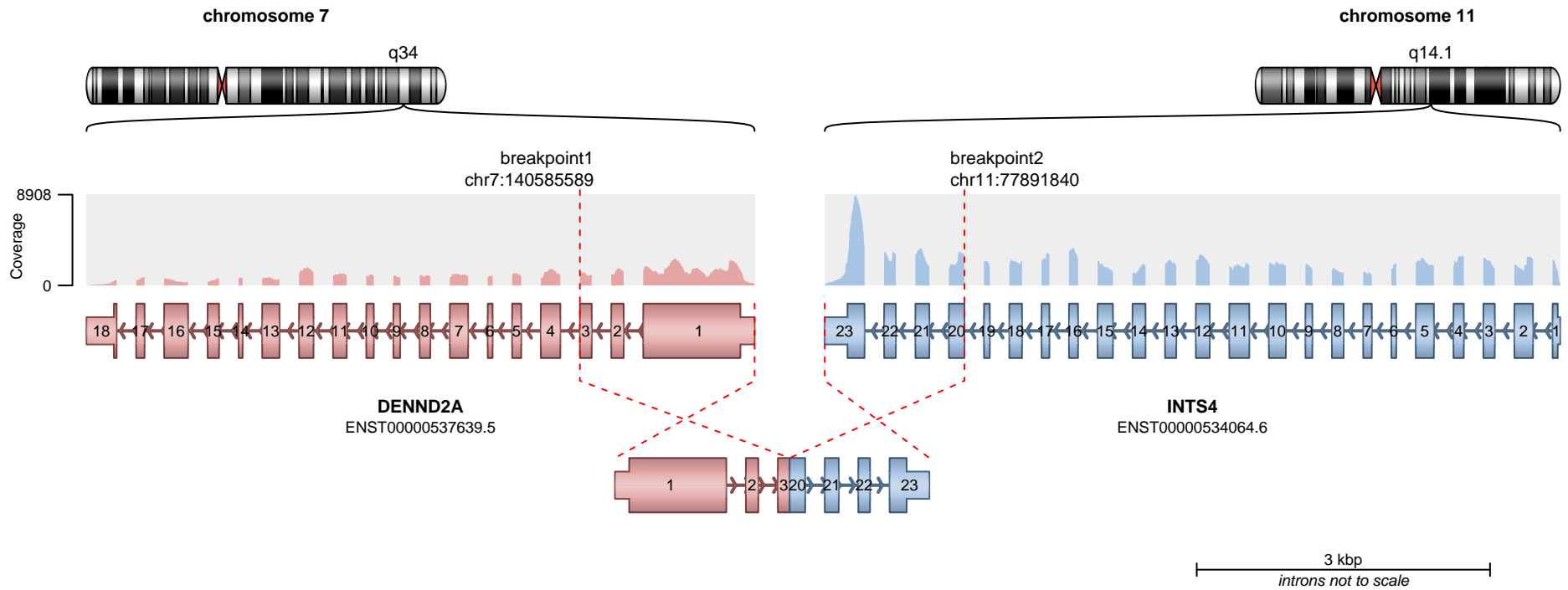

— translocation    — deletion  
 — duplication    — inversion

No protein domains retained in fusion.

**SUPPORTING READ COUNT**

Split reads = 5  
Discordant mates = 0

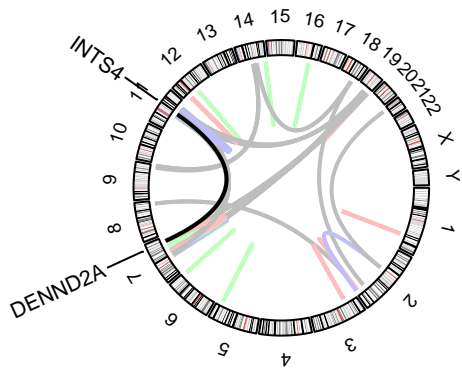
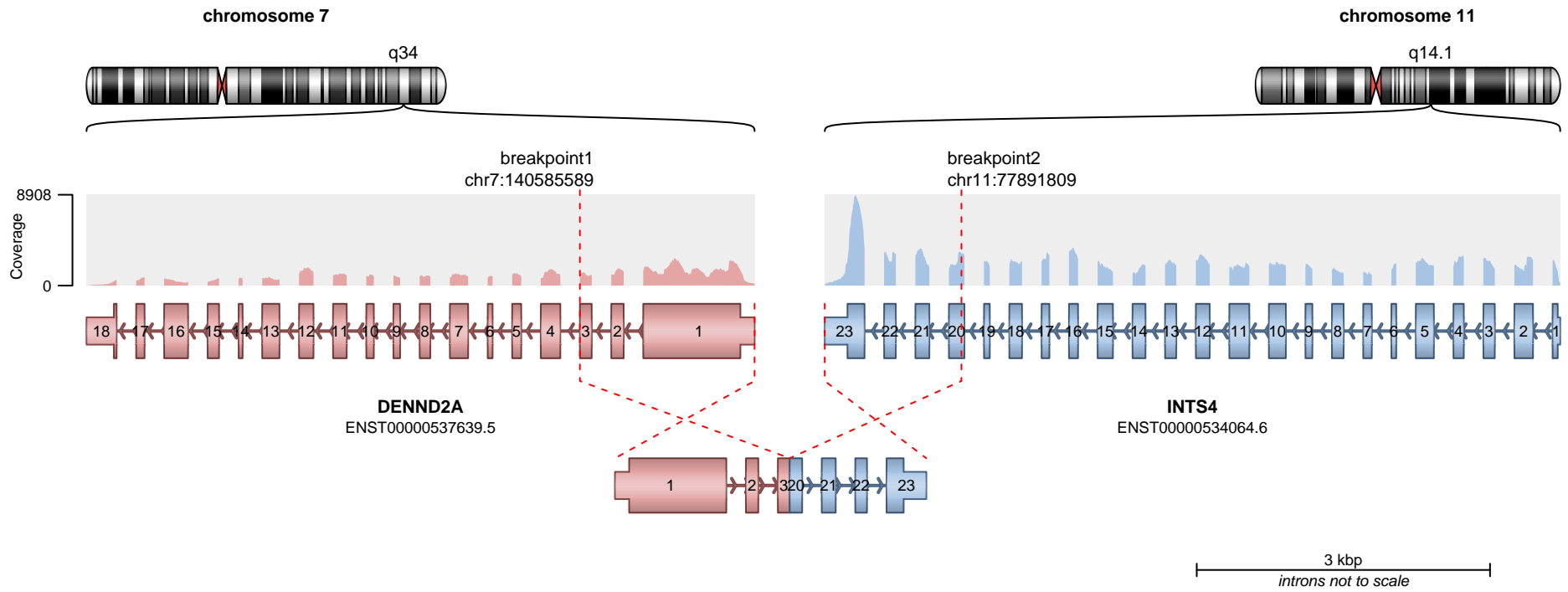

No protein domains retained in fusion.

**SUPPORTING READ COUNT**

Split reads = 3  
Discordant mates = 0

— translocation    — deletion  
— duplication    — inversion

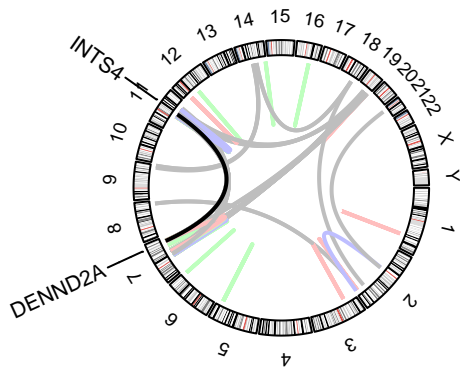
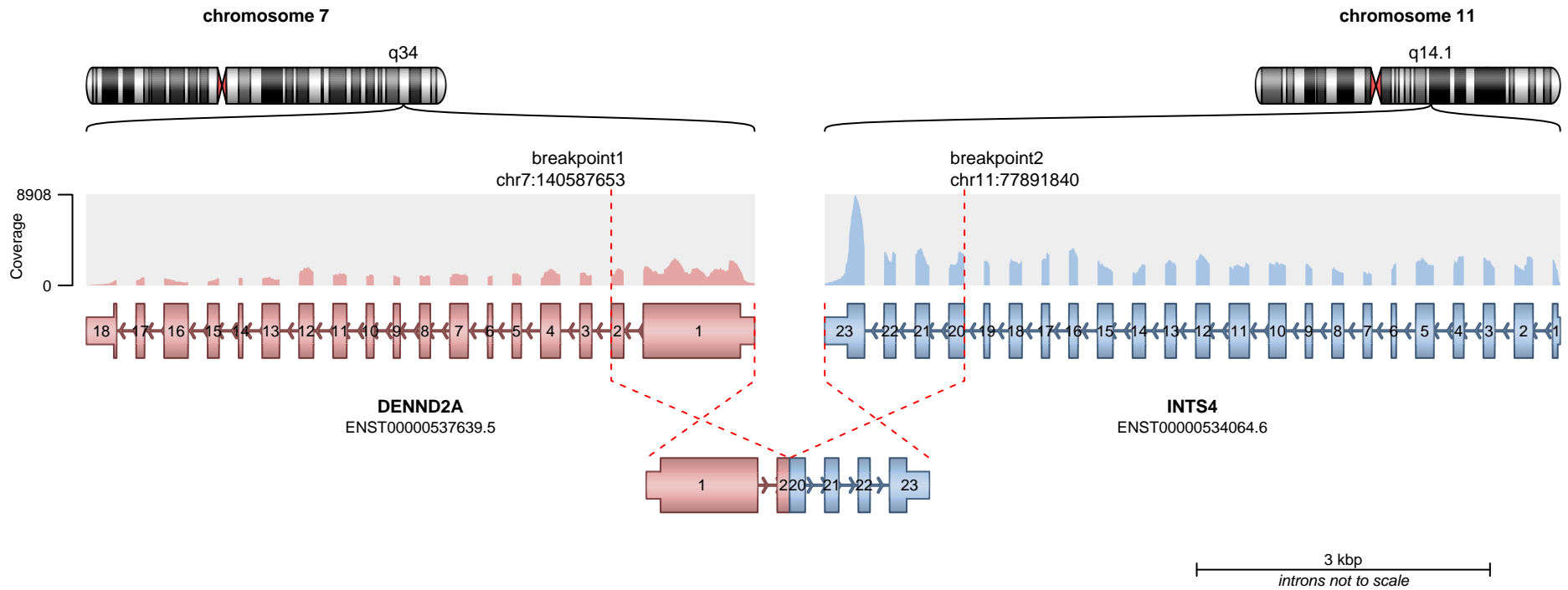

No protein domains retained in fusion.

**SUPPORTING READ COUNT**

Split reads = 1  
Discordant mates = 0

— translocation    — deletion  
— duplication    — inversion

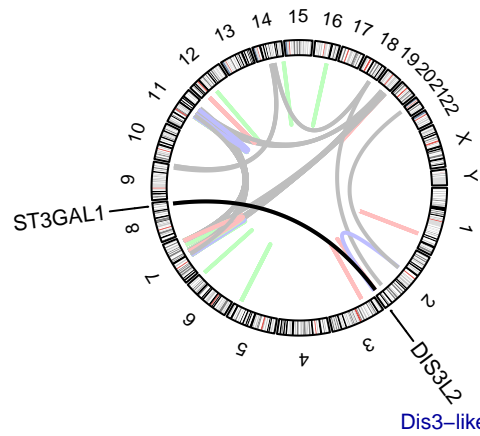
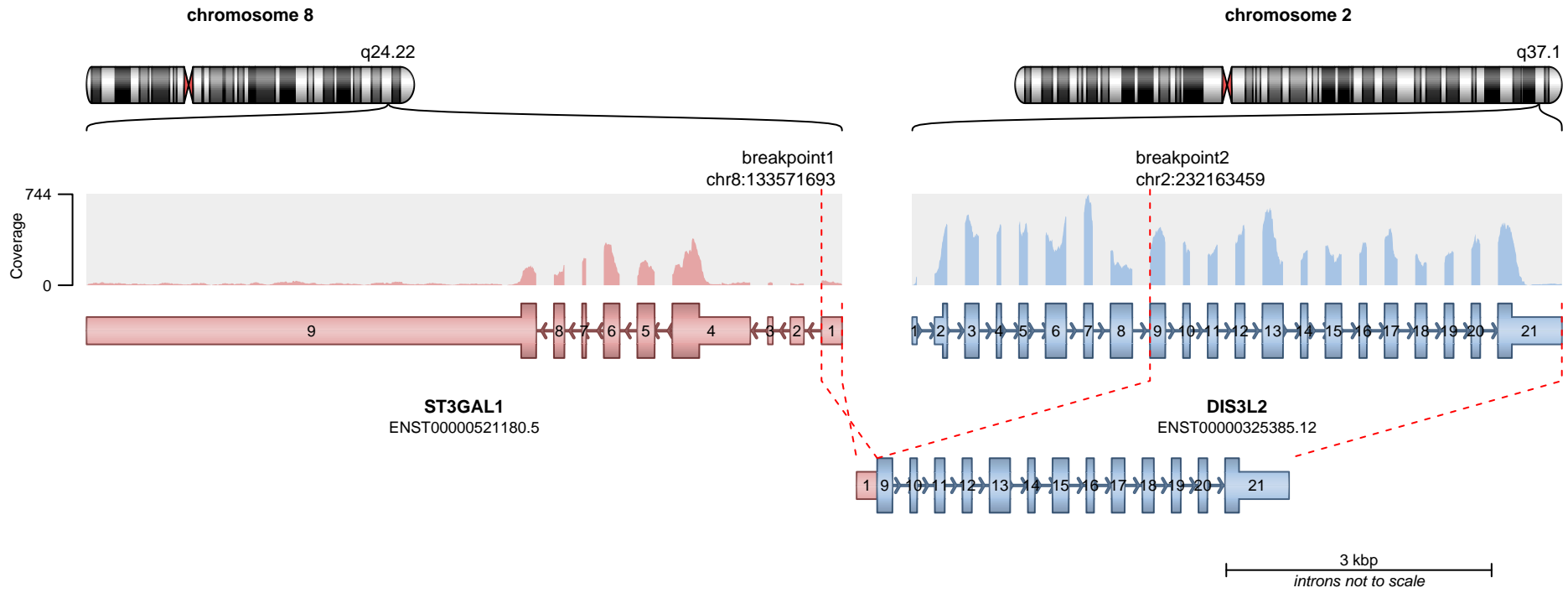

**RETAINED PROTEIN DOMAINS**  
reading frame unclear

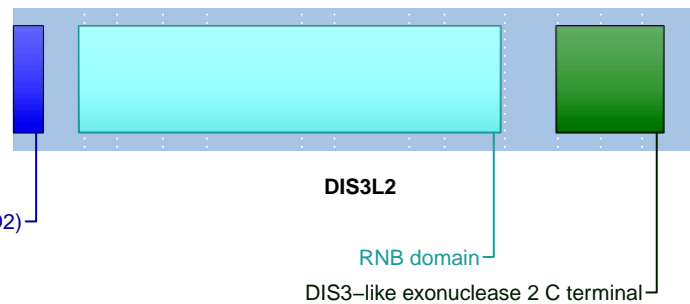

**SUPPORTING READ COUNT**

Split reads = 18  
Discordant mates = 0

- translocation
- duplication
- deletion
- inversion

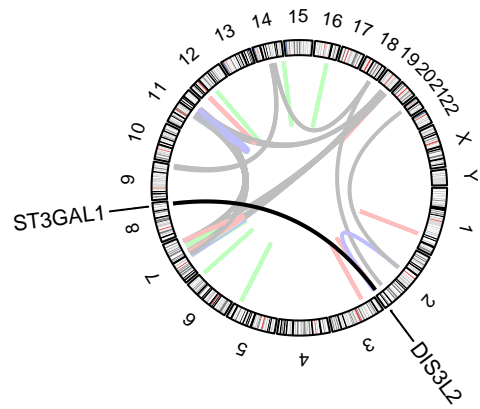
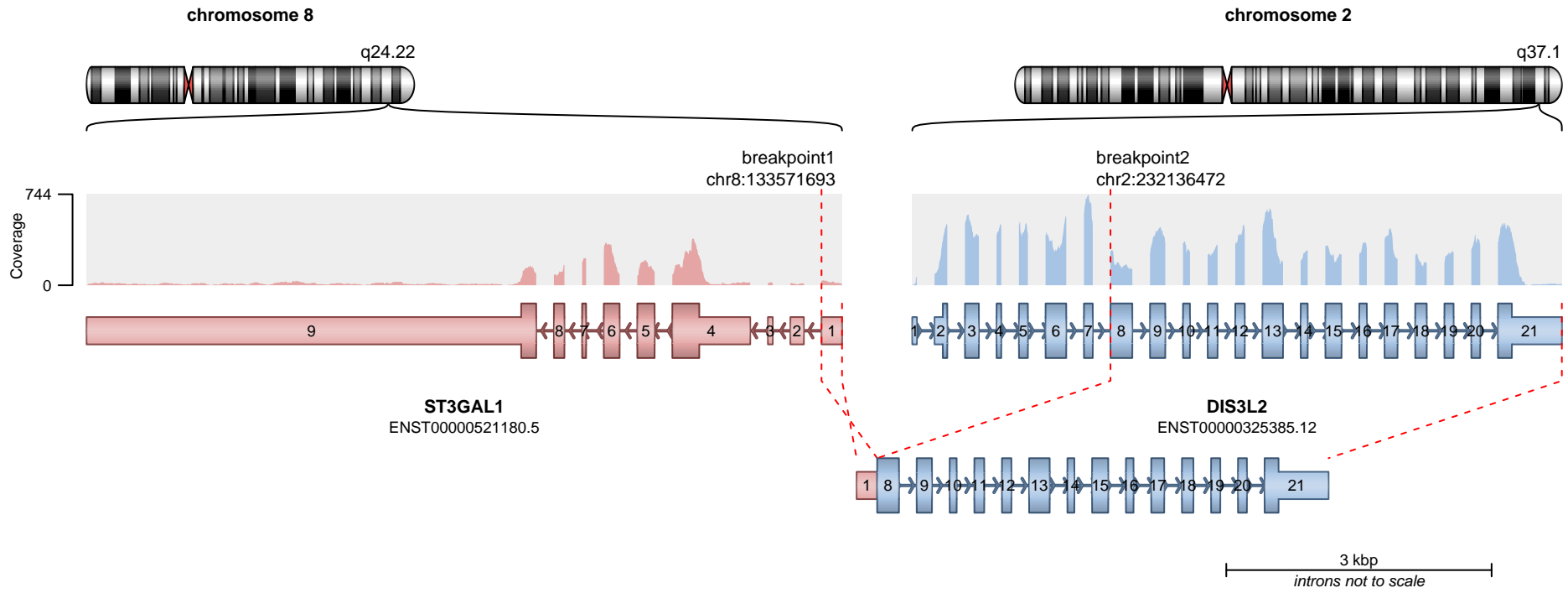

— translocation — deletion  
— duplication — inversion

**RETAINED PROTEIN DOMAINS**  
reading frame unclear

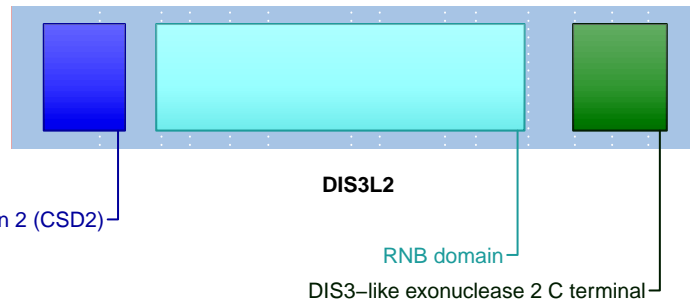

**SUPPORTING READ COUNT**

Split reads = 1  
Discordant mates = 0

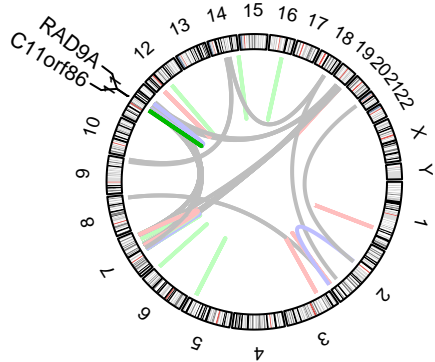
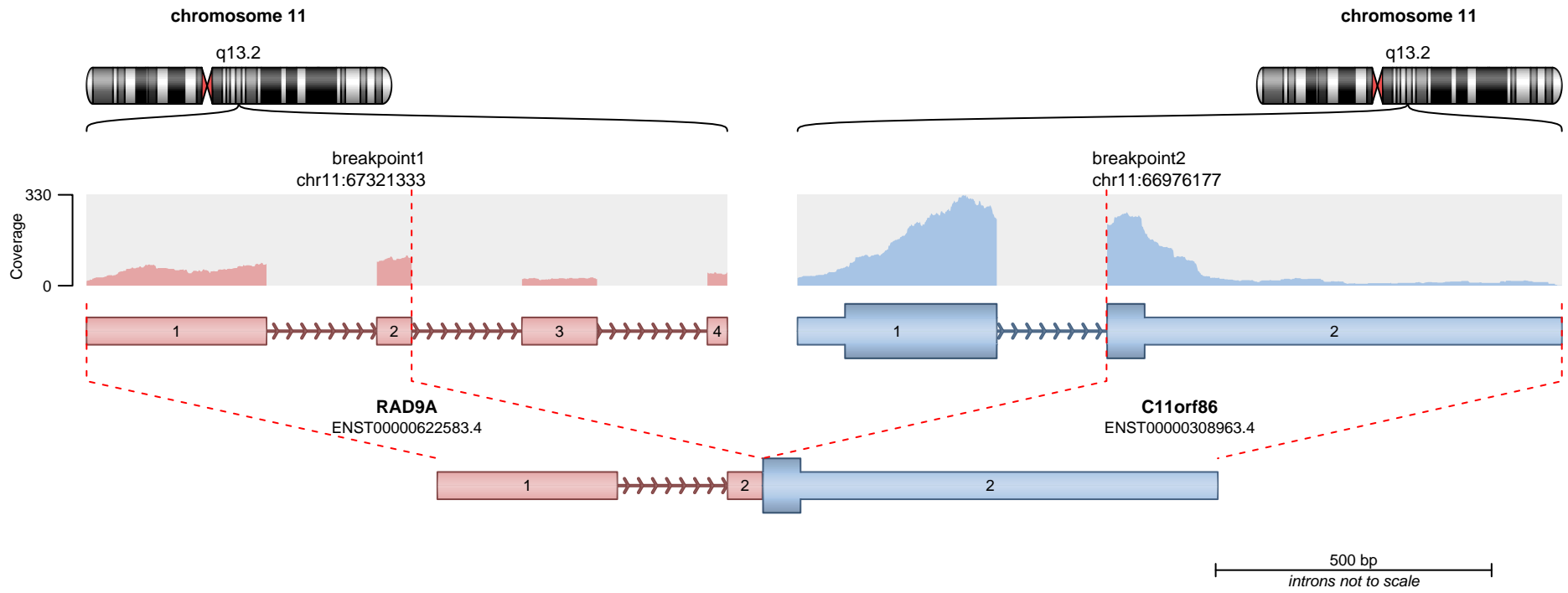

— translocation    — deletion  
— duplication    — inversion

**RETAINED PROTEIN DOMAINS**  
reading frame unclear



**C11orf86**  
Domain of unknown function (DUF4633)

**SUPPORTING READ COUNT**

Split reads = 16  
Discordant mates = 0

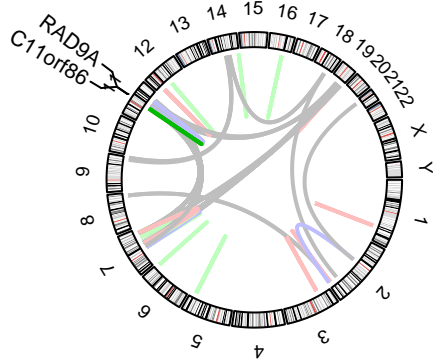
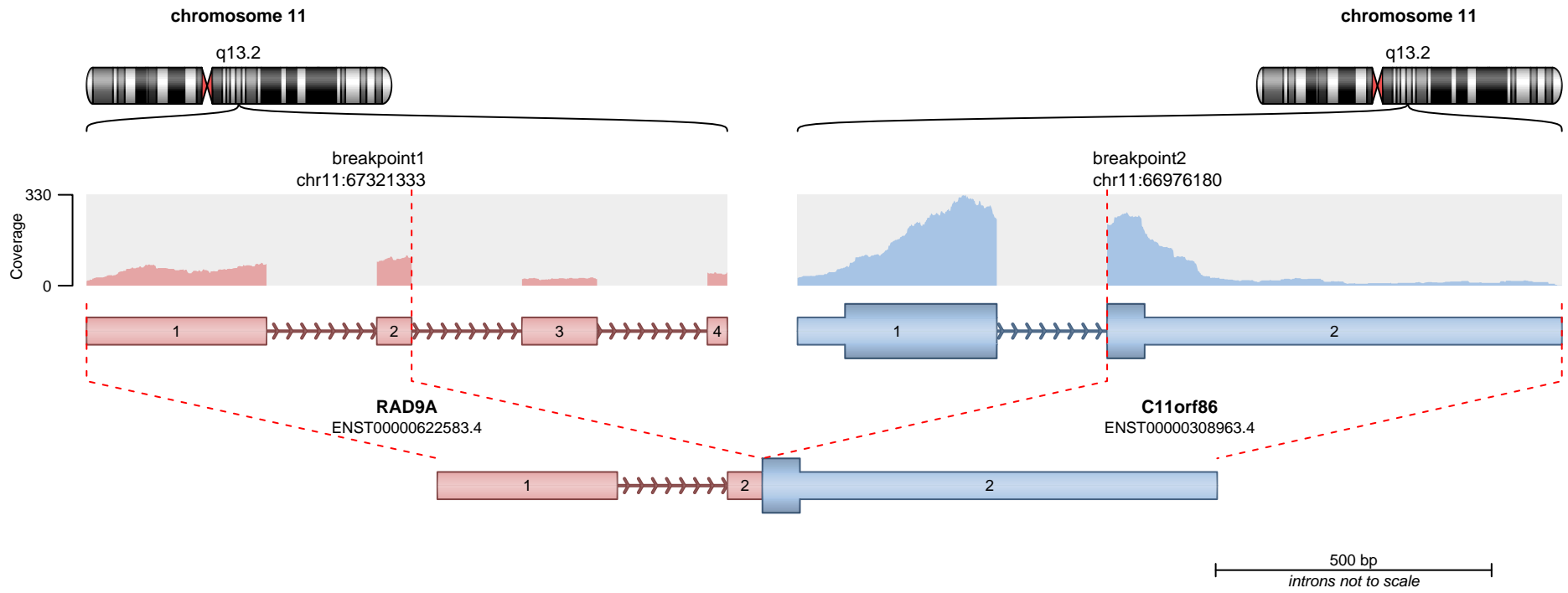

— translocation — deletion  
— duplication — inversion

**RETAINED PROTEIN DOMAINS**  
reading frame unclear



**C11orf86**  
Domain of unknown function (DUF4633)

**SUPPORTING READ COUNT**

Split reads = 4  
Discordant mates = 0

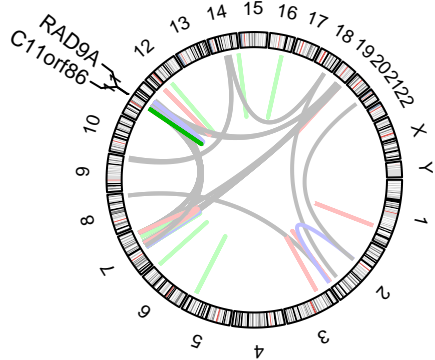
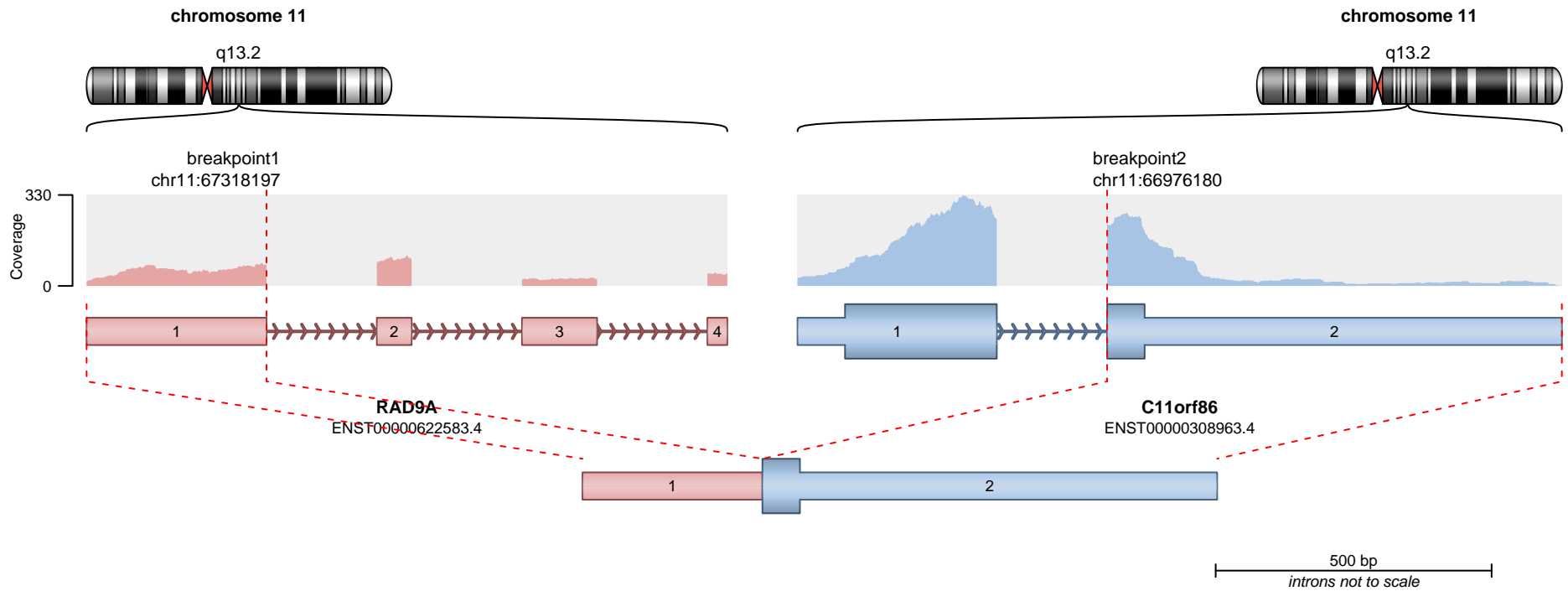

— translocation    — deletion  
 — duplication    — inversion

**RETAINED PROTEIN DOMAINS**  
reading frame unclear



**C11orf86**  
Domain of unknown function (DUF4633)

**SUPPORTING READ COUNT**

Split reads = 1  
Discordant mates = 0

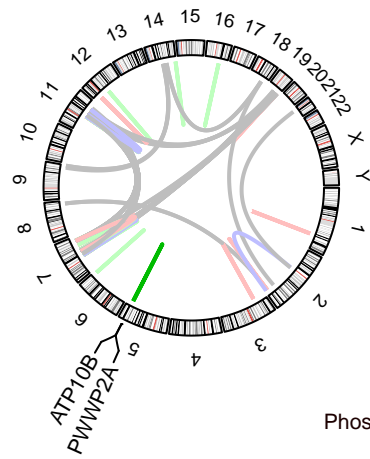
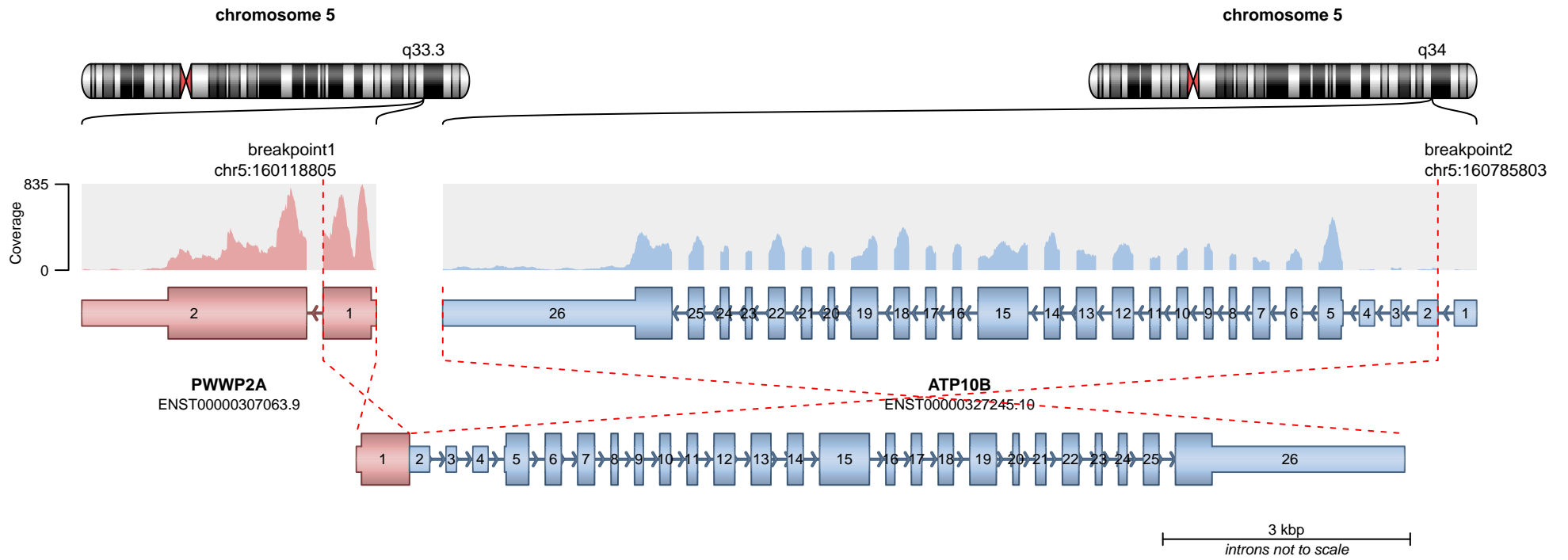

**RETAINED PROTEIN DOMAINS**  
reading frame unclear

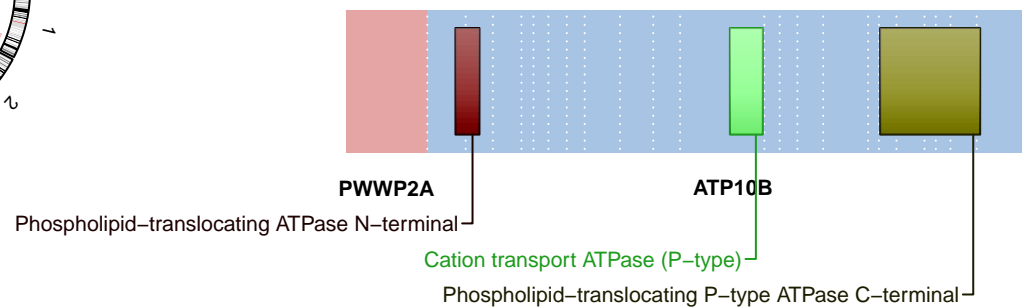

**SUPPORTING READ COUNT**

Split reads = 15  
Discordant mates = 0

— translocation — deletion  
— duplication — inversion

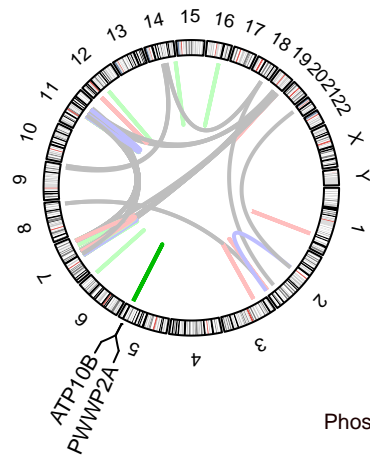
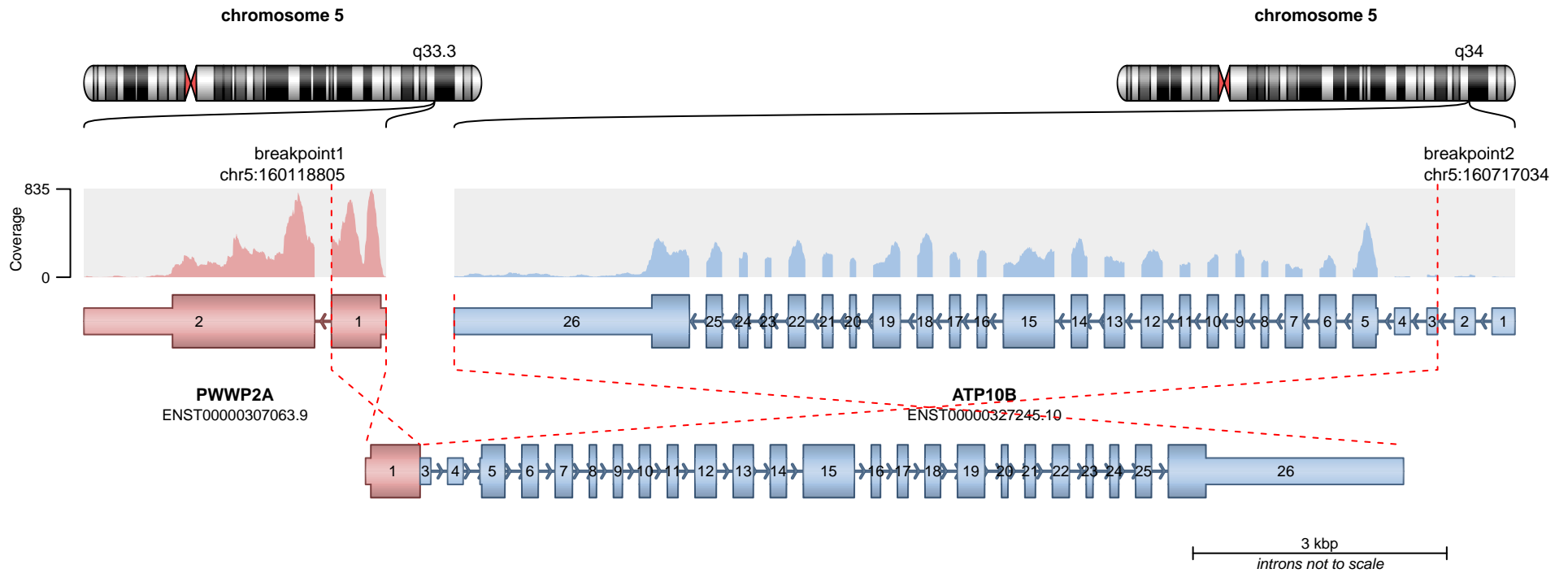

**RETAINED PROTEIN DOMAINS**  
reading frame unclear

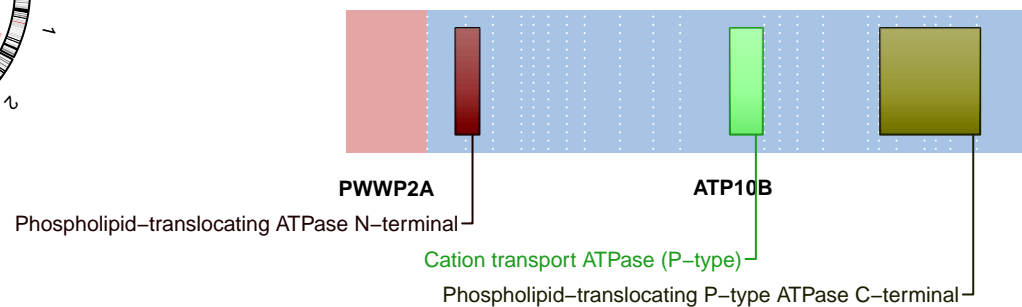

**SUPPORTING READ COUNT**

Split reads = 3  
Discordant mates = 0

— translocation    — deletion  
— duplication    — inversion

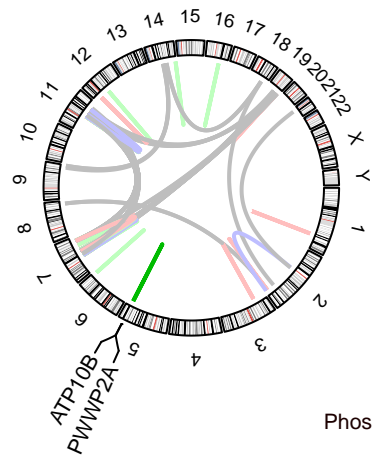
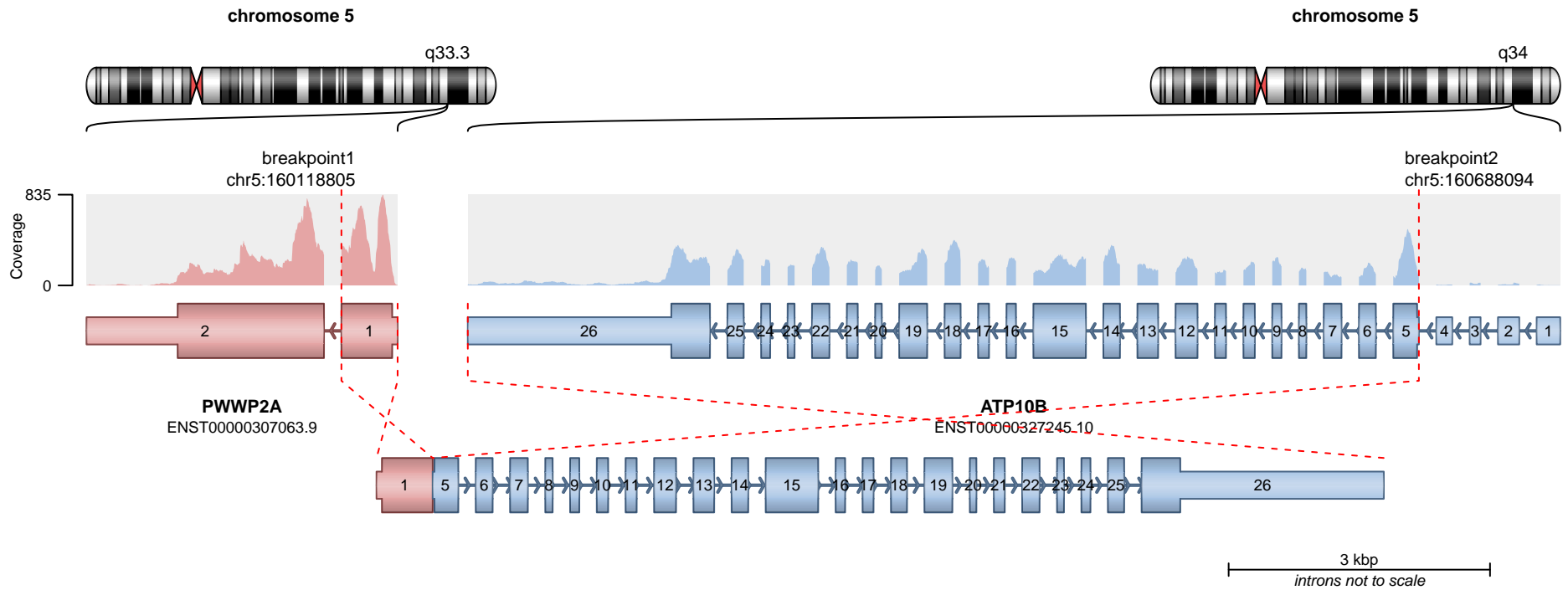

**RETAINED PROTEIN DOMAINS**  
reading frame unclear

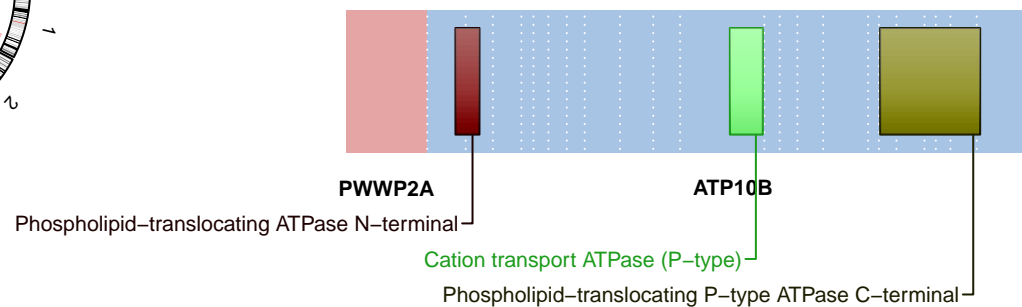

**SUPPORTING READ COUNT**

Split reads = 1  
Discordant mates = 0

- translocation
- duplication
- deletion
- inversion

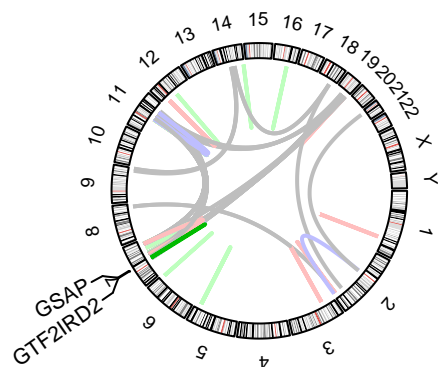
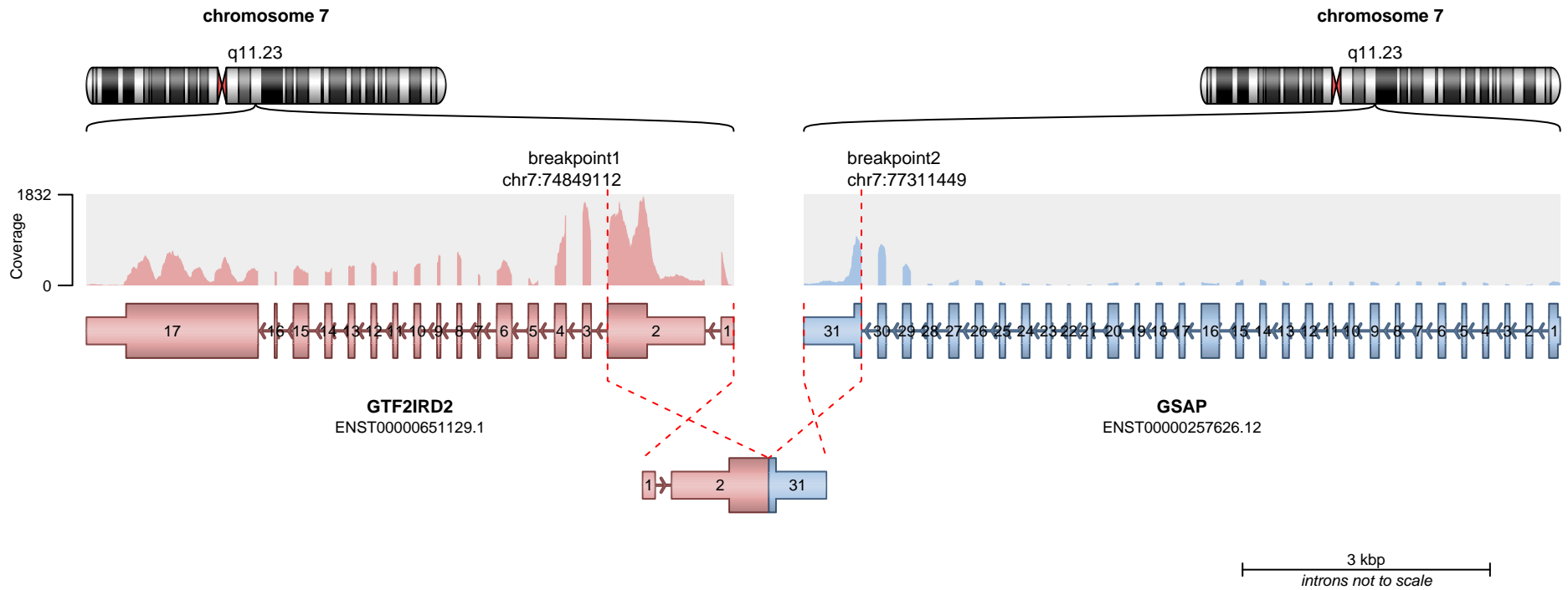

**RETAINED PROTEIN DOMAINS**  
reading frame unclear

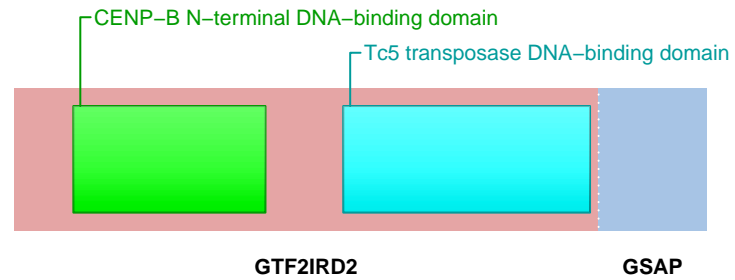

**SUPPORTING READ COUNT**

Split reads = 14  
Discordant mates = 0

- translocation
- duplication
- deletion
- inversion

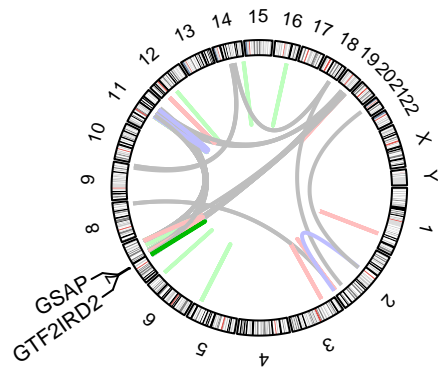
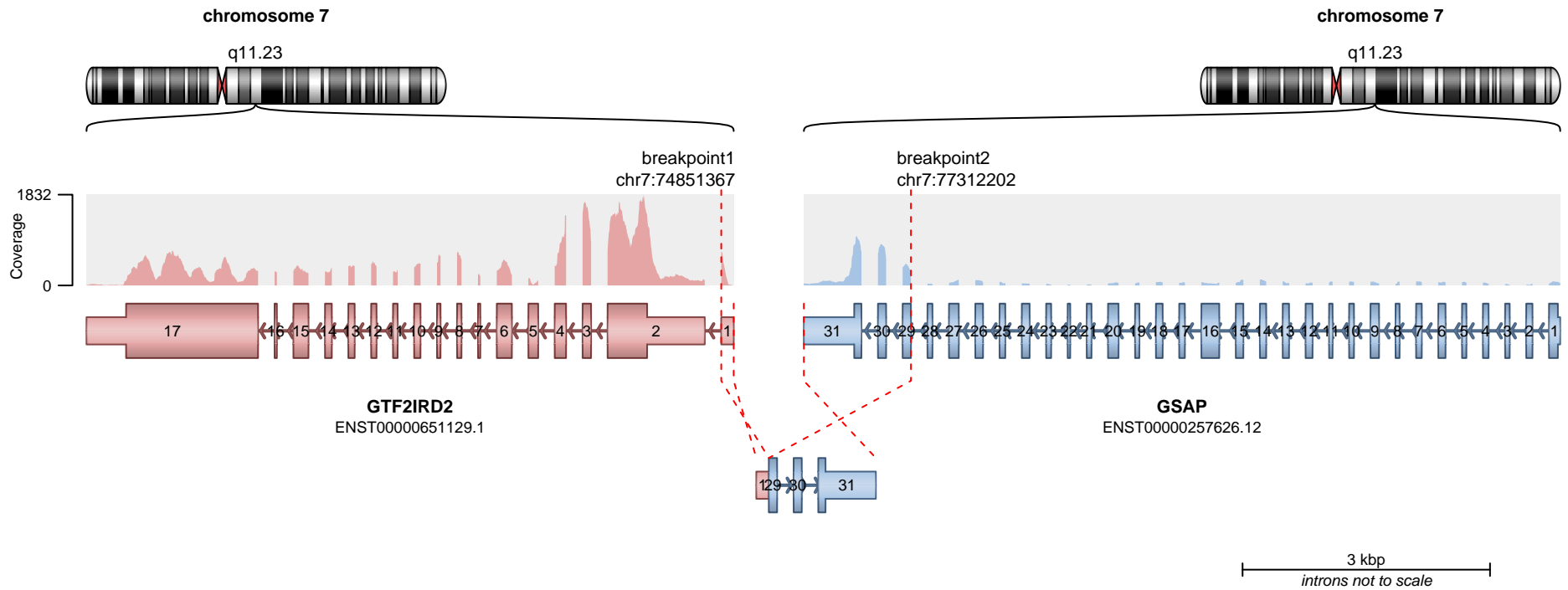

— translocation    — deletion  
— duplication      — inversion

No protein domains retained in fusion.

**SUPPORTING READ COUNT**

Split reads = 14  
Discordant mates = 0

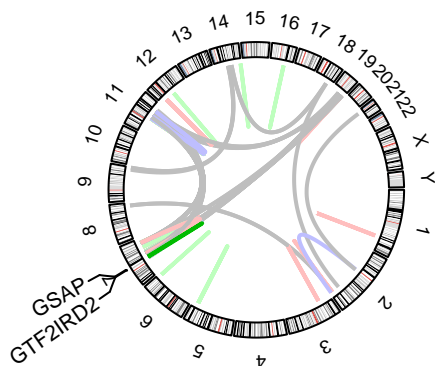
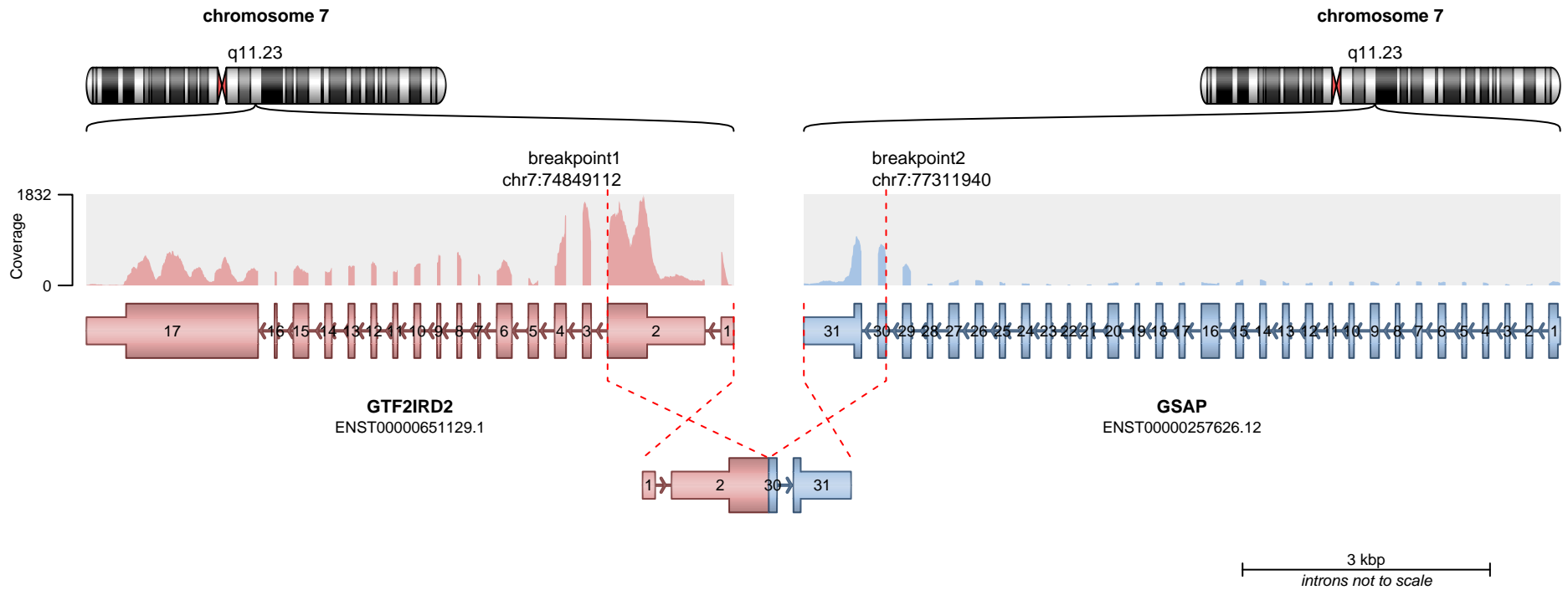

**RETAINED PROTEIN DOMAINS**  
reading frame unclear

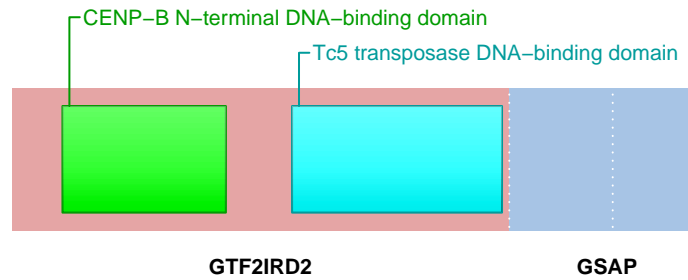

**SUPPORTING READ COUNT**

Split reads = 3  
Discordant mates = 0

— translocation    — deletion  
— duplication    — inversion

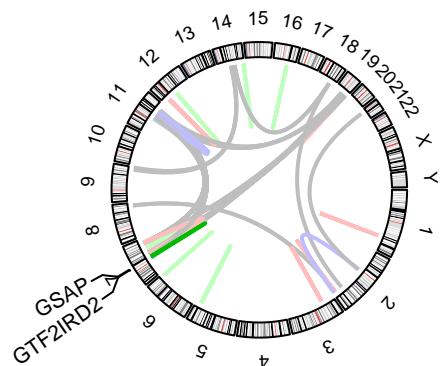
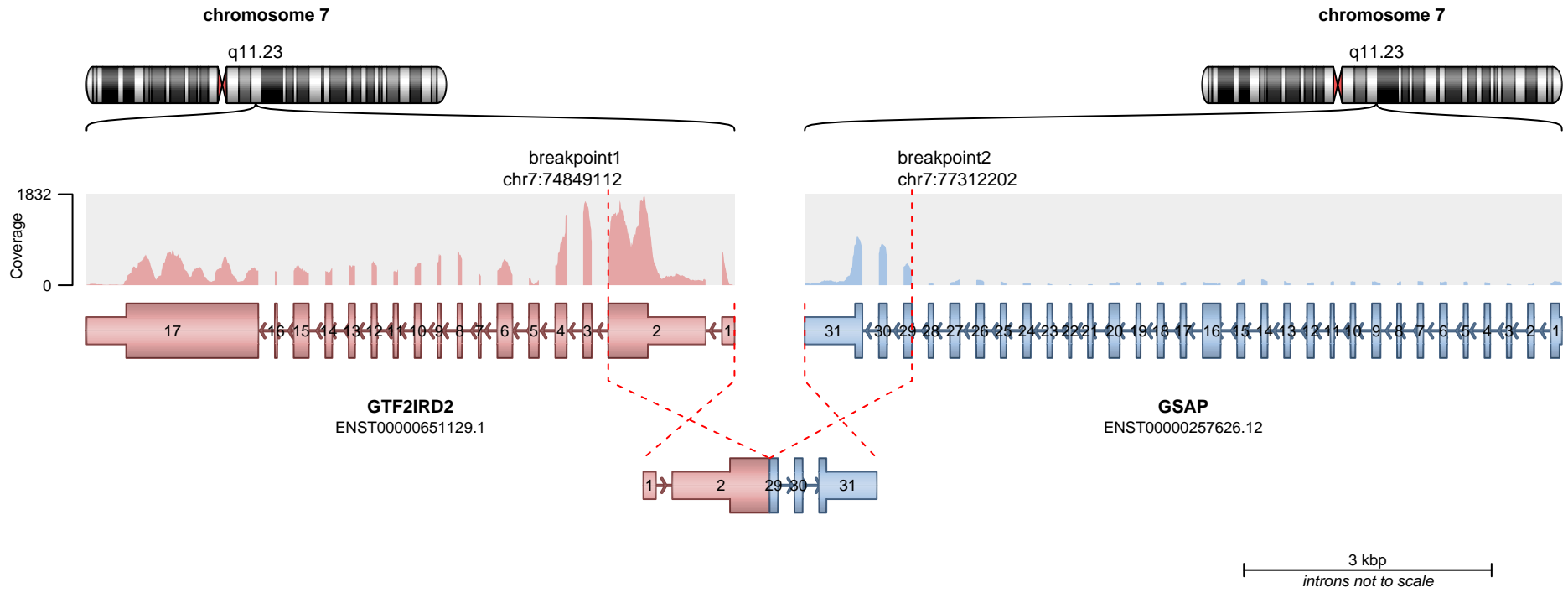

**RETAINED PROTEIN DOMAINS**  
reading frame unclear

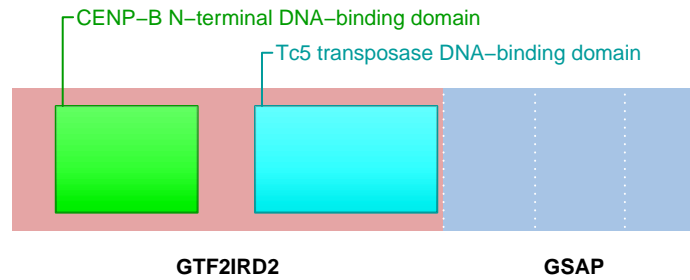

**SUPPORTING READ COUNT**

Split reads = 2  
Discordant mates = 0

- translocation
- duplication
- deletion
- inversion

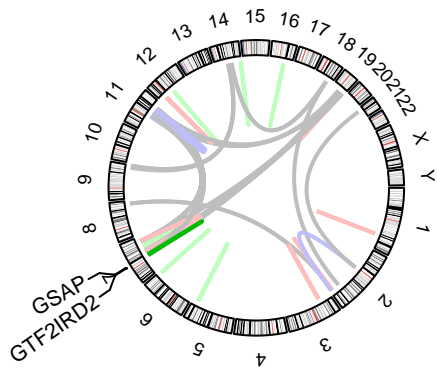
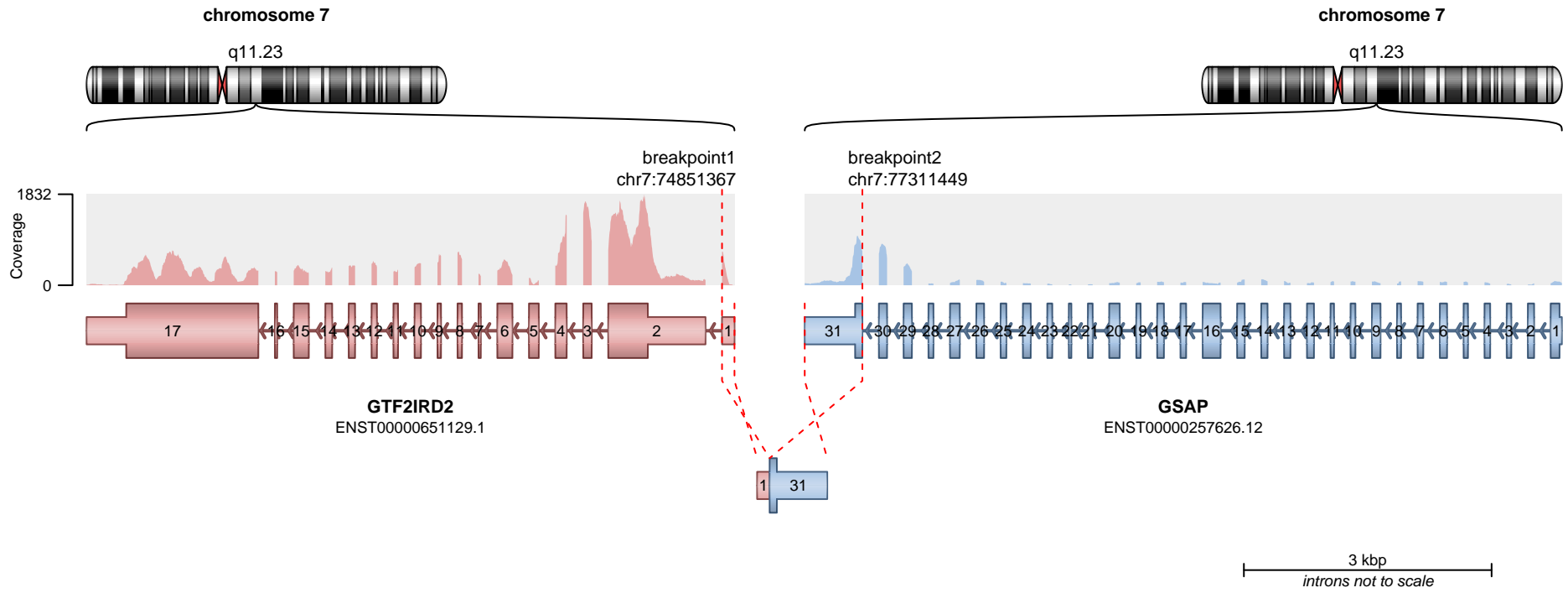

— translocation    — deletion  
— duplication    — inversion

No protein domains retained in fusion.

**SUPPORTING READ COUNT**

Split reads = 1  
Discordant mates = 0

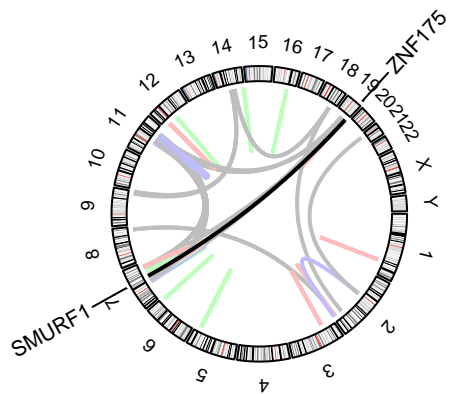
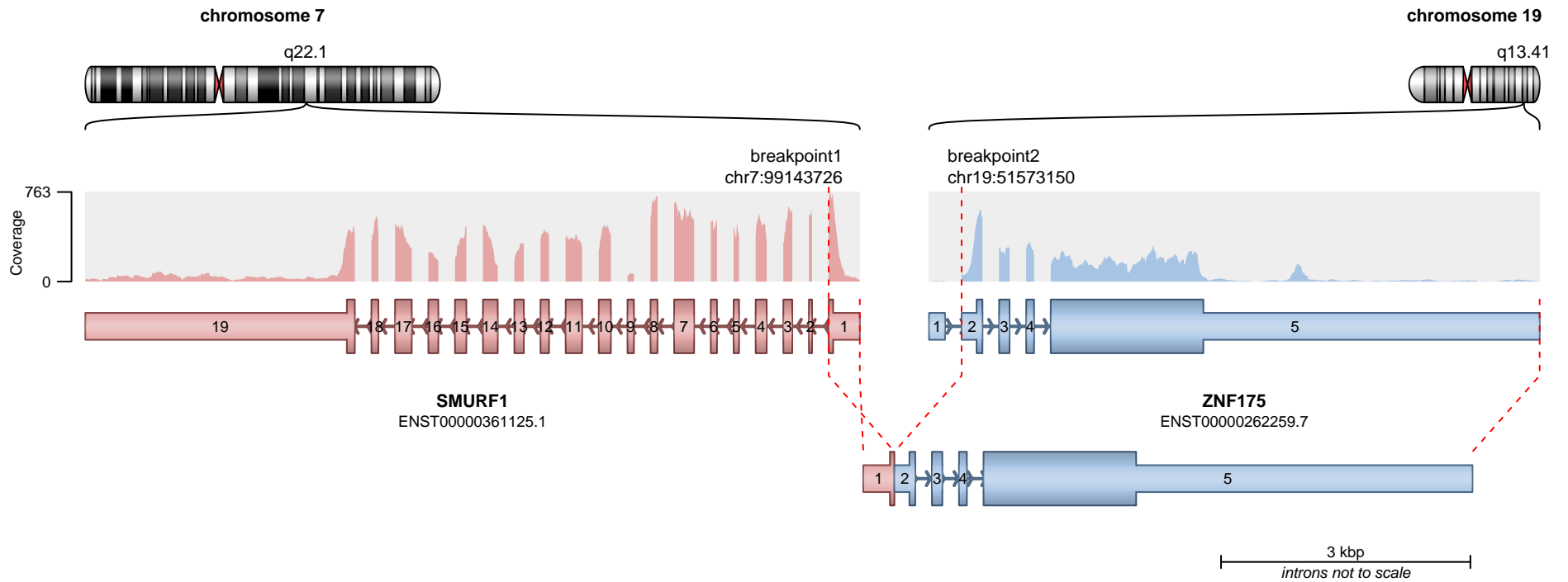

**RETAINED PROTEIN DOMAINS**  
reading frame unclear

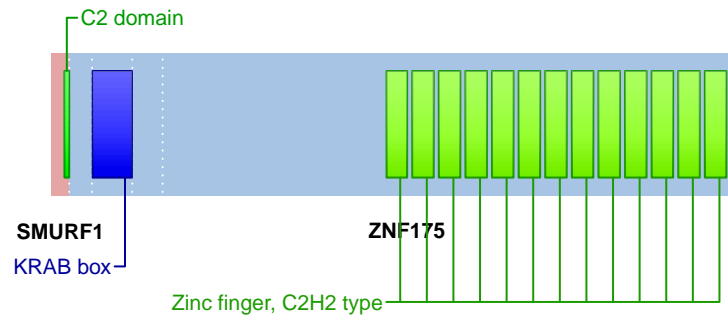

**SUPPORTING READ COUNT**

Split reads = 14  
Discordant mates = 0

- translocation
- duplication
- deletion
- inversion

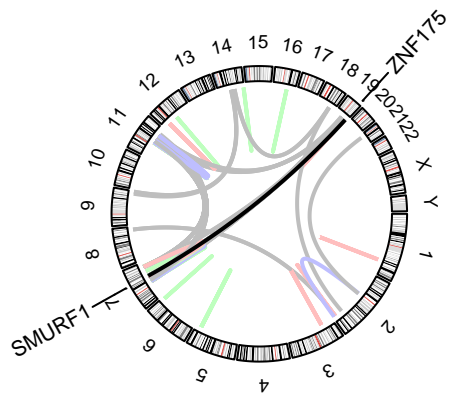
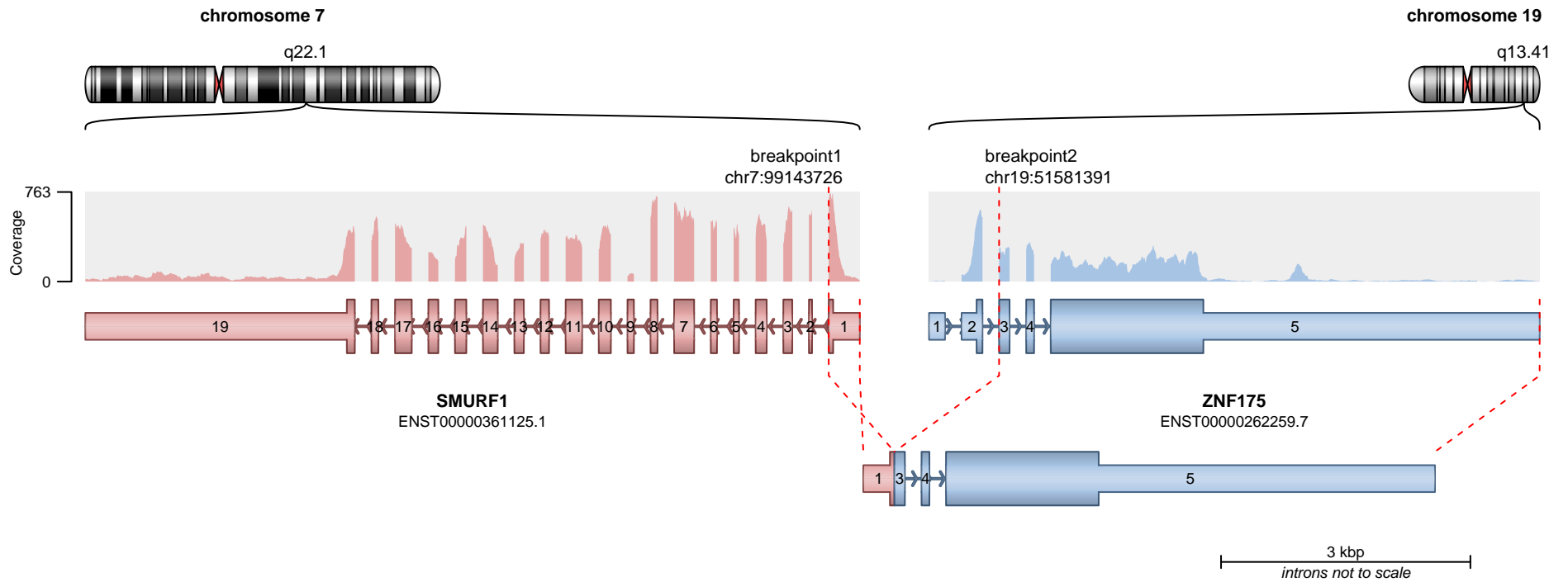

**RETAINED PROTEIN DOMAINS**  
reading frame unclear

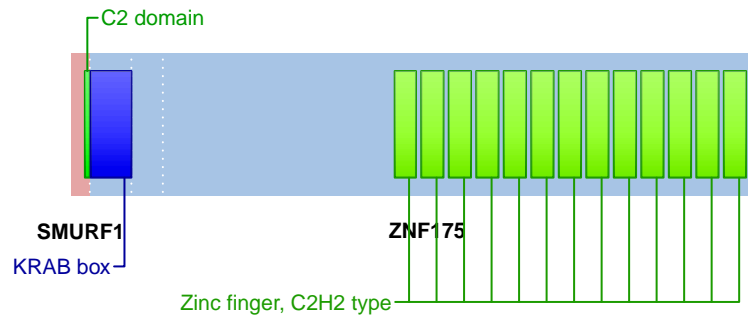

**SUPPORTING READ COUNT**

Split reads = 7  
Discordant mates = 0

- translocation
- duplication
- deletion
- inversion

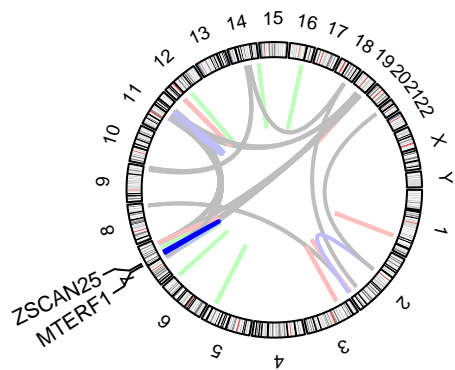
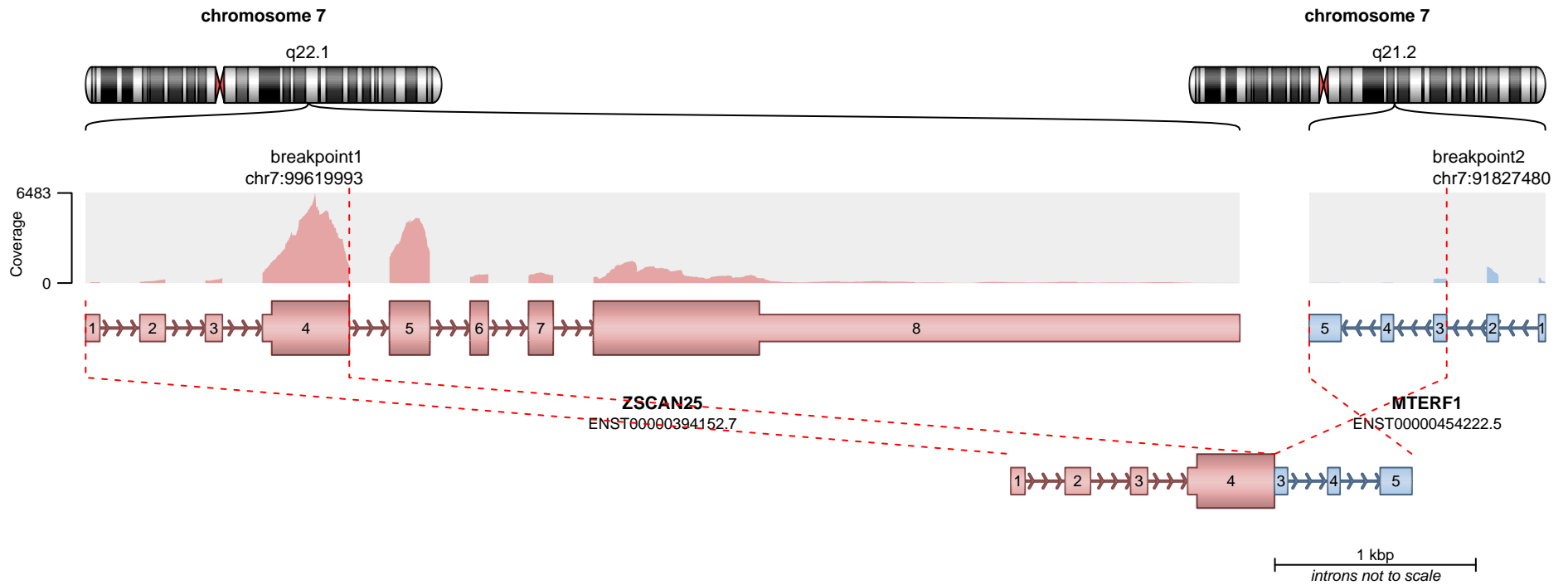

**RETAINED PROTEIN DOMAINS**  
reading frame unclear

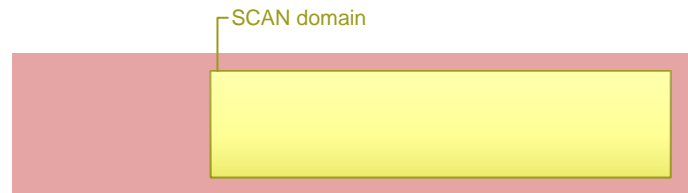

**ZSCAN25**

**SUPPORTING READ COUNT**

Split reads = 14  
Discordant mates = 0

— translocation    — deletion  
— duplication    — inversion

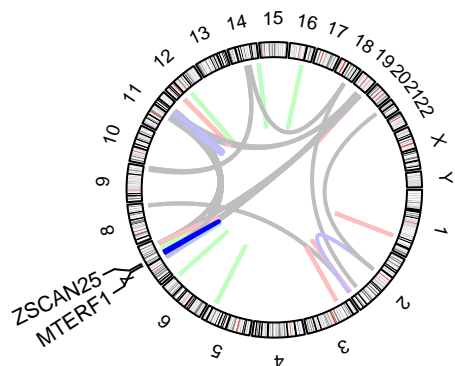
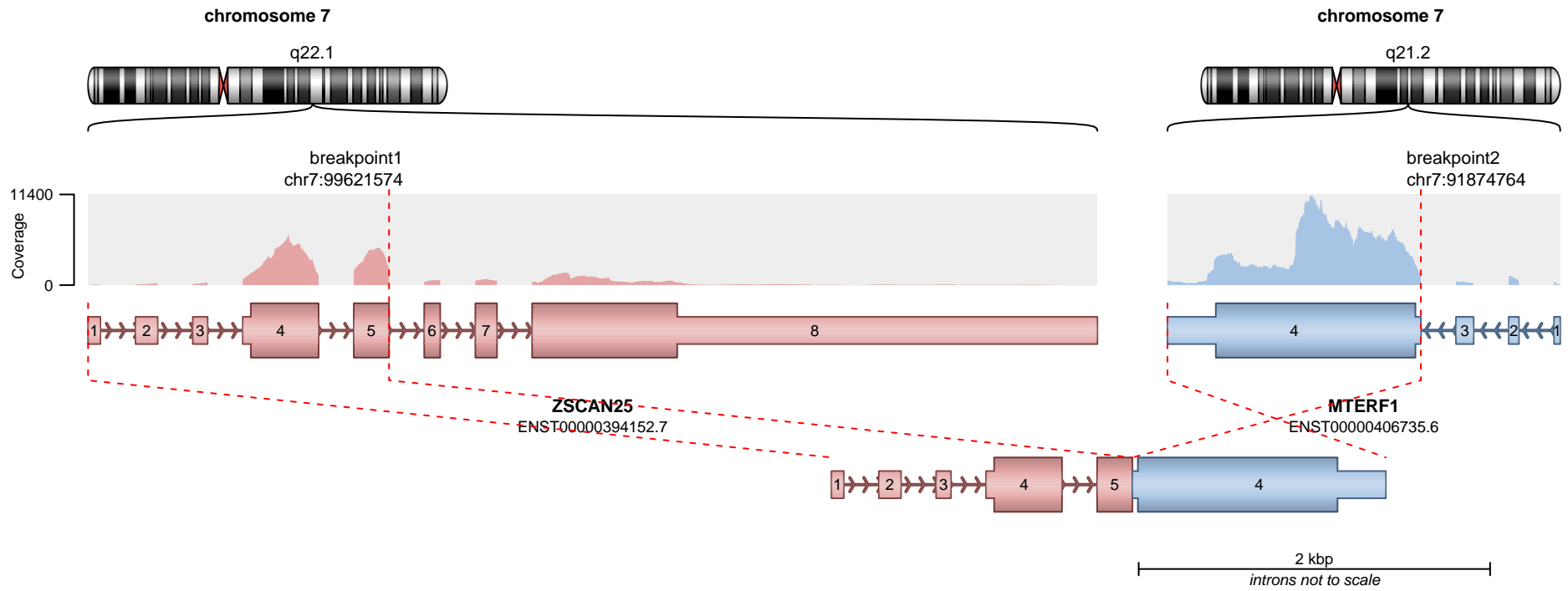

**RETAINED PROTEIN DOMAINS**  
reading frame unclear

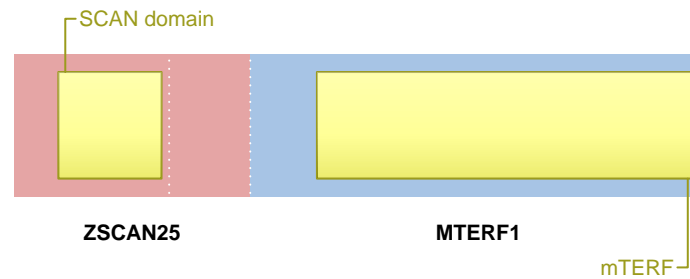

**SUPPORTING READ COUNT**

Split reads = 2  
Discordant mates = 0

— translocation    — deletion  
— duplication    — inversion

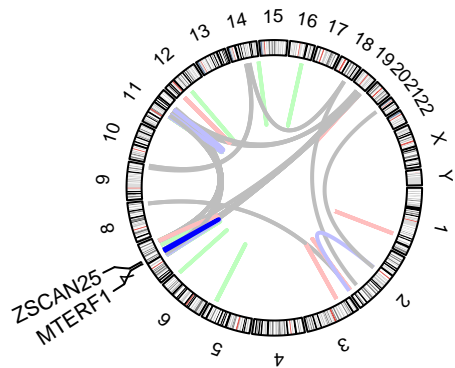
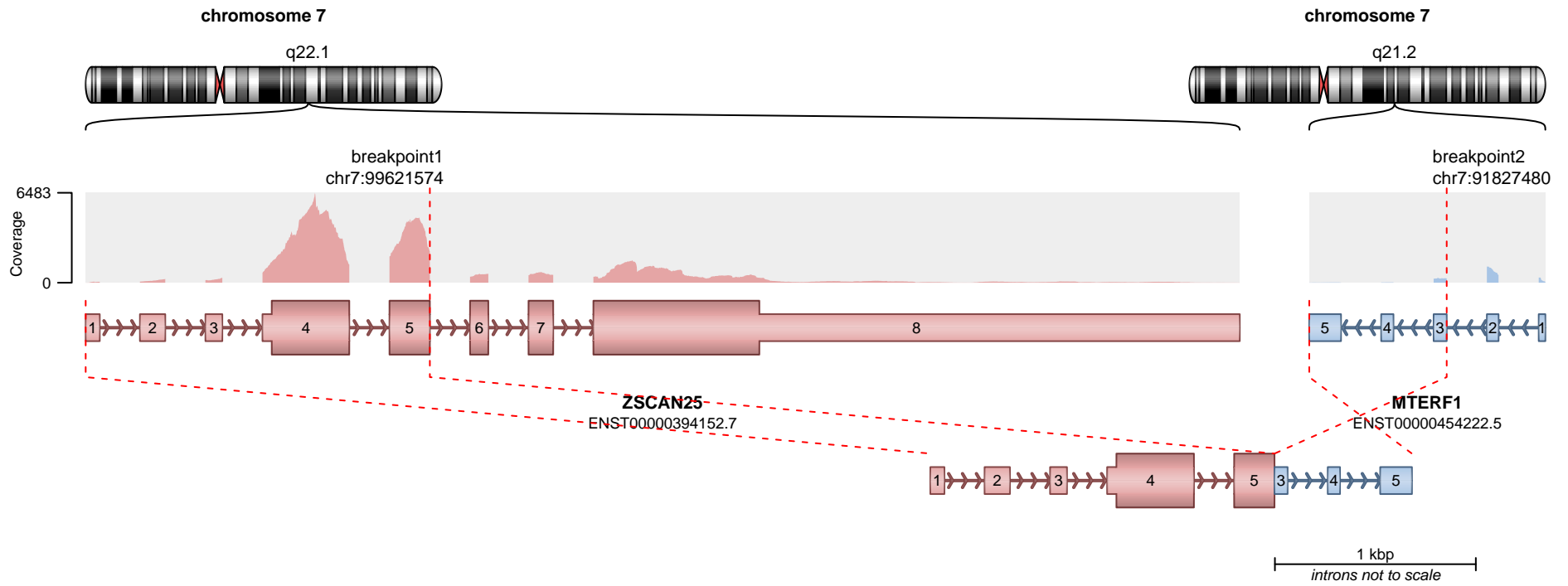

**RETAINED PROTEIN DOMAINS**  
reading frame unclear

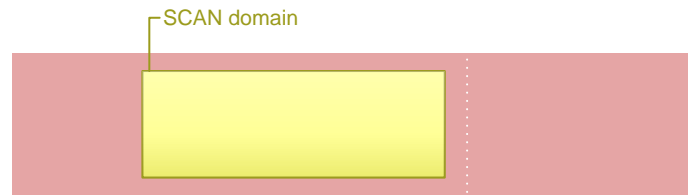

**SUPPORTING READ COUNT**

Split reads = 1  
Discordant mates = 0

- translocation
- duplication
- deletion
- inversion

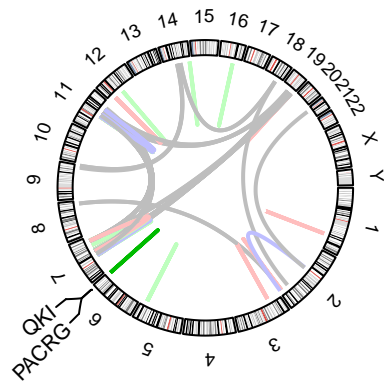
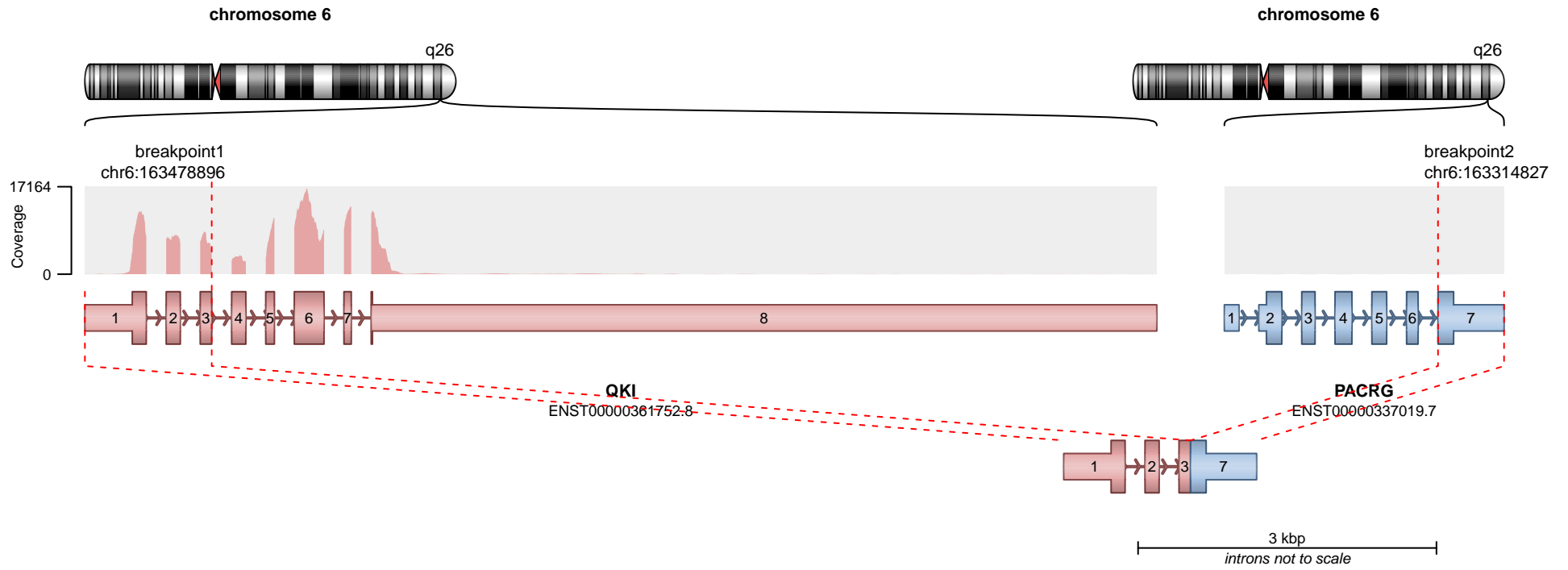

**RETAINED PROTEIN DOMAINS**  
reading frame unclear

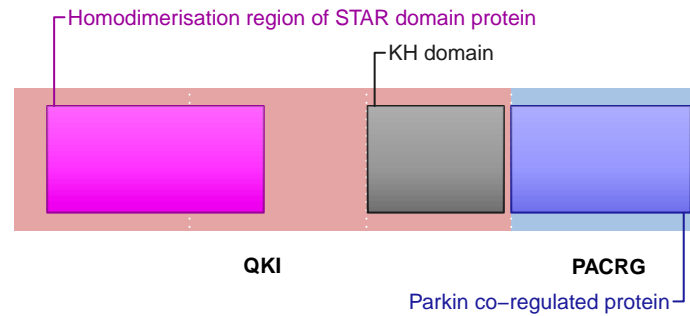

**SUPPORTING READ COUNT**

Split reads = 13  
Discordant mates = 0

— translocation    — deletion  
— duplication    — inversion

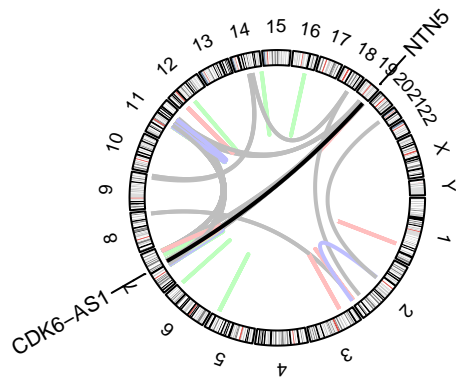
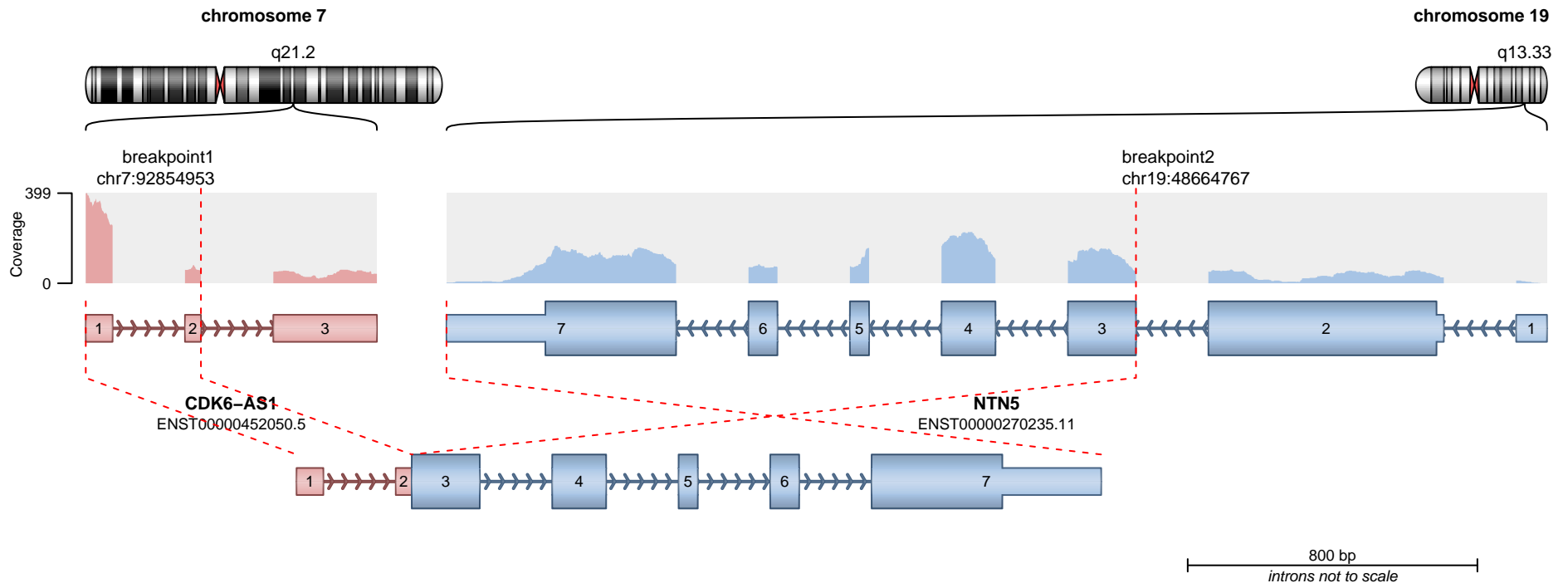

**RETAINED PROTEIN DOMAINS**  
reading frame unclear

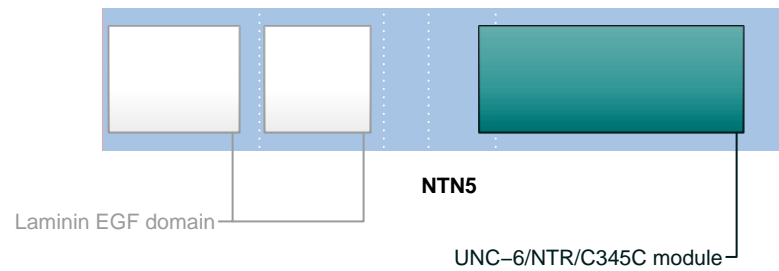

**SUPPORTING READ COUNT**

Split reads = 12  
Discordant mates = 0

— translocation    — deletion  
— duplication    — inversion

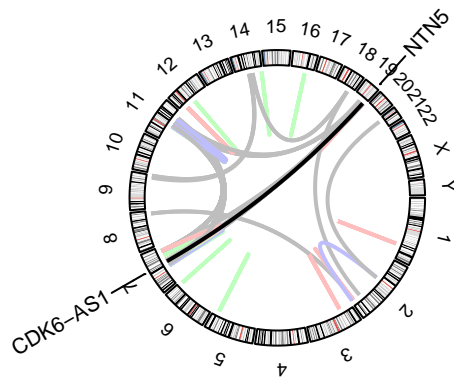
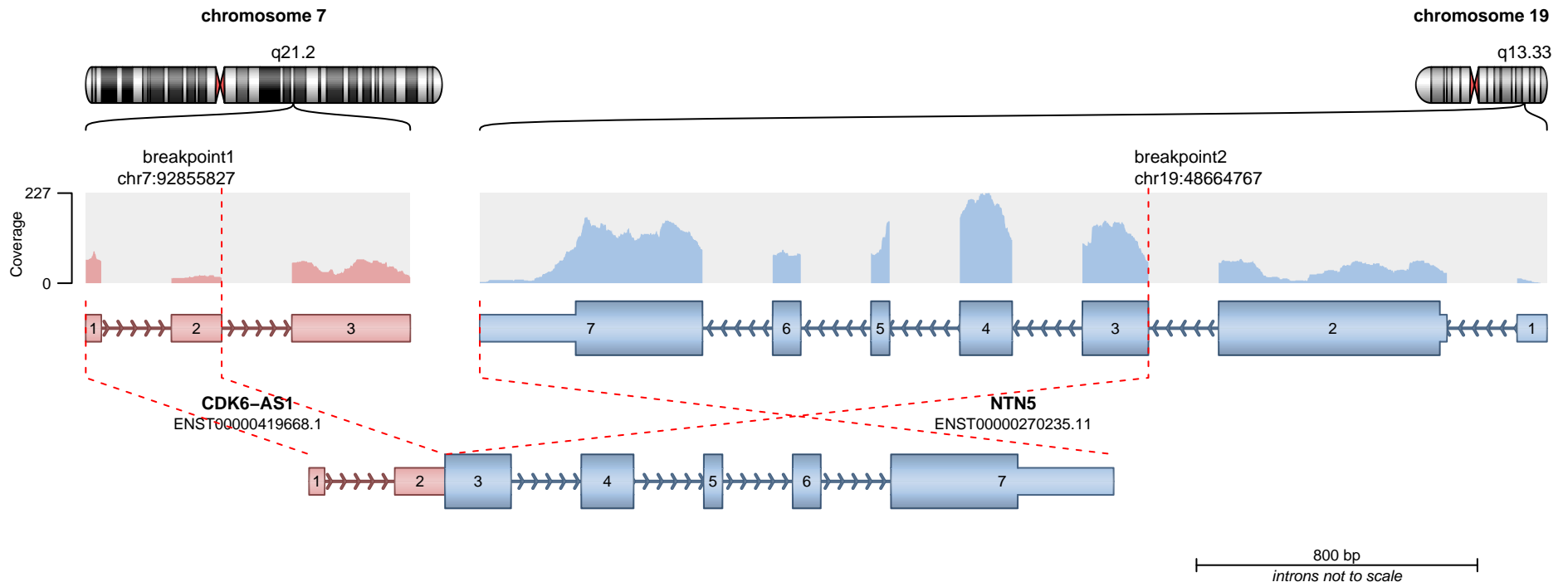

**RETAINED PROTEIN DOMAINS**  
reading frame unclear

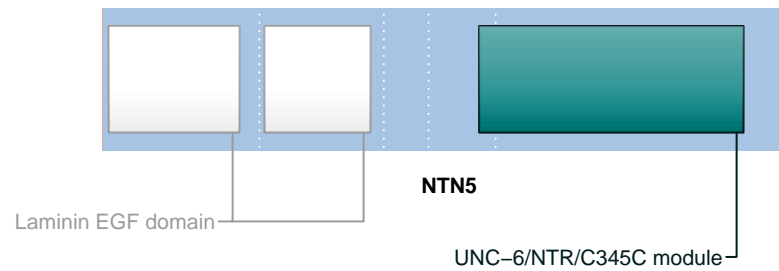

**SUPPORTING READ COUNT**

Split reads = 4  
Discordant mates = 0

— translocation    — deletion  
— duplication    — inversion

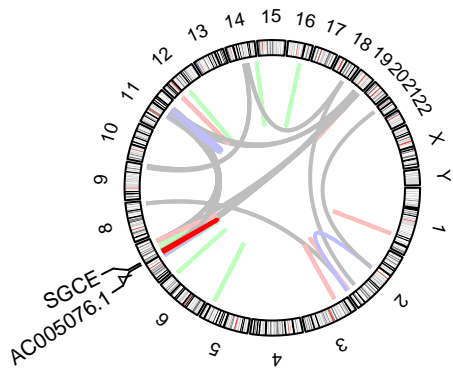
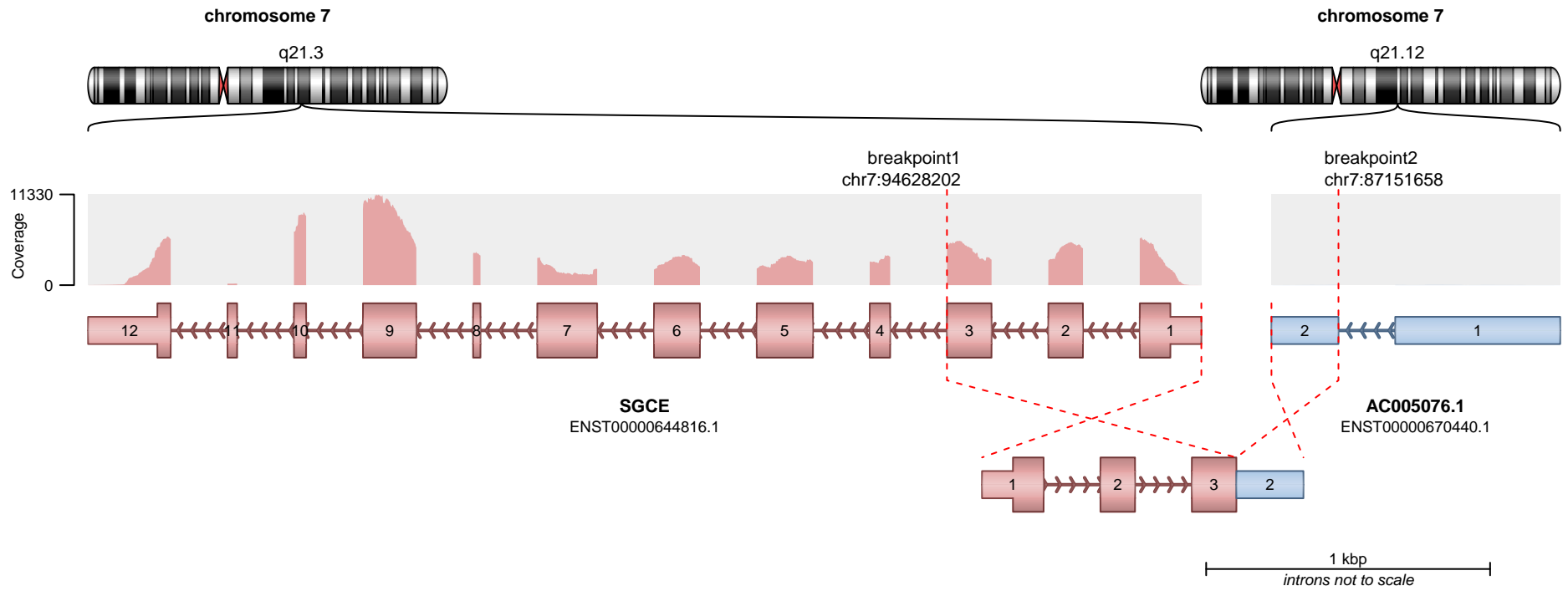

**RETAINED PROTEIN DOMAINS**  
reading frame unclear

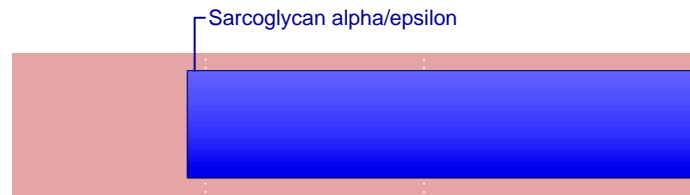

SGCE

**SUPPORTING READ COUNT**

Split reads = 12  
Discordant mates = 0

- translocation
- duplication
- deletion
- inversion

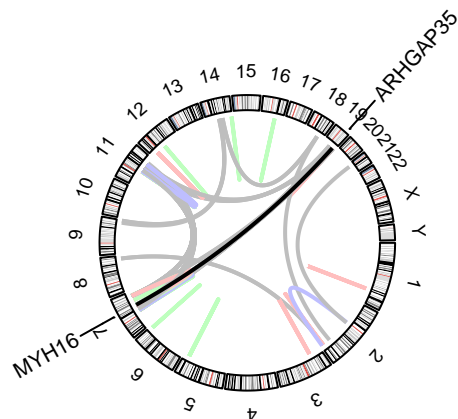
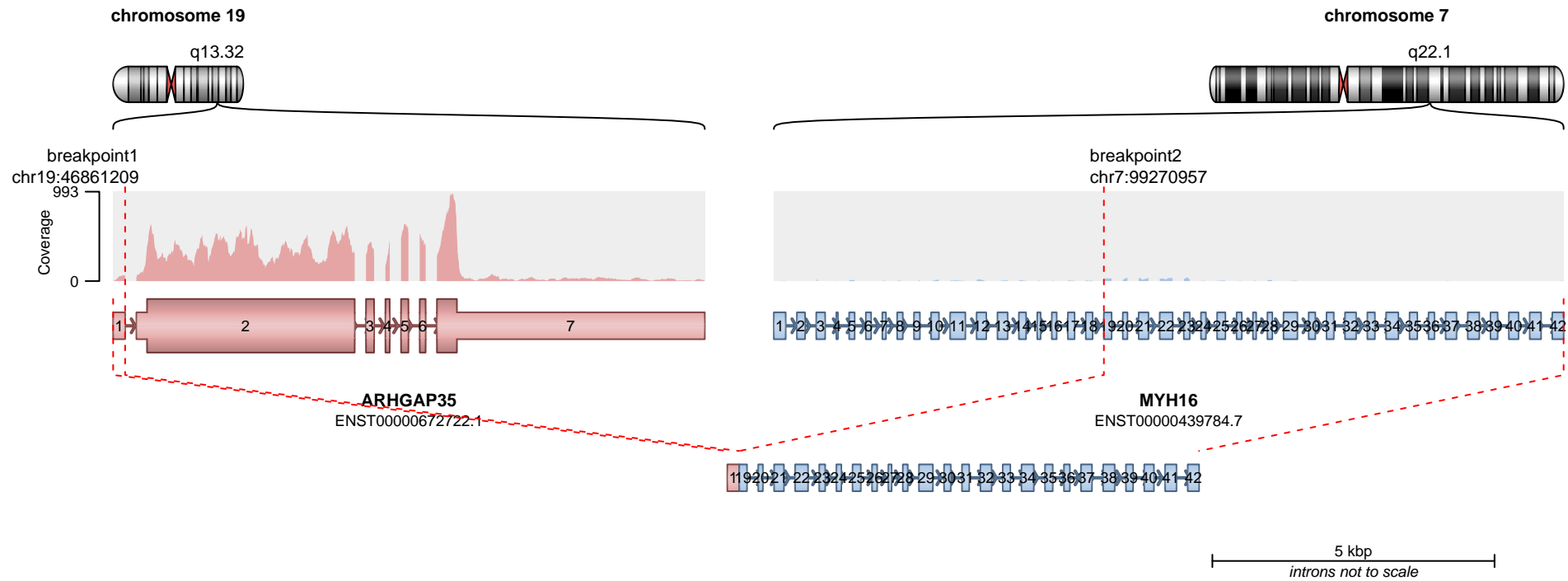

— translocation    — deletion  
— duplication    — inversion

No coding regions retained in fusion transcript.

**SUPPORTING READ COUNT**

Split reads = 11  
Discordant mates = 1

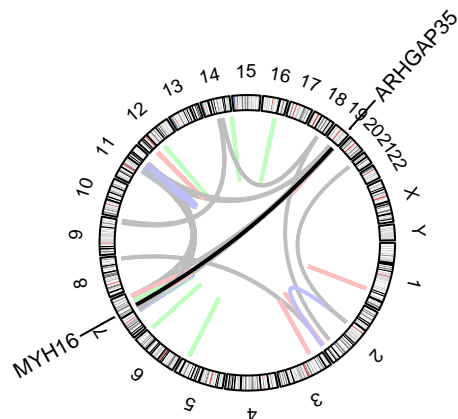
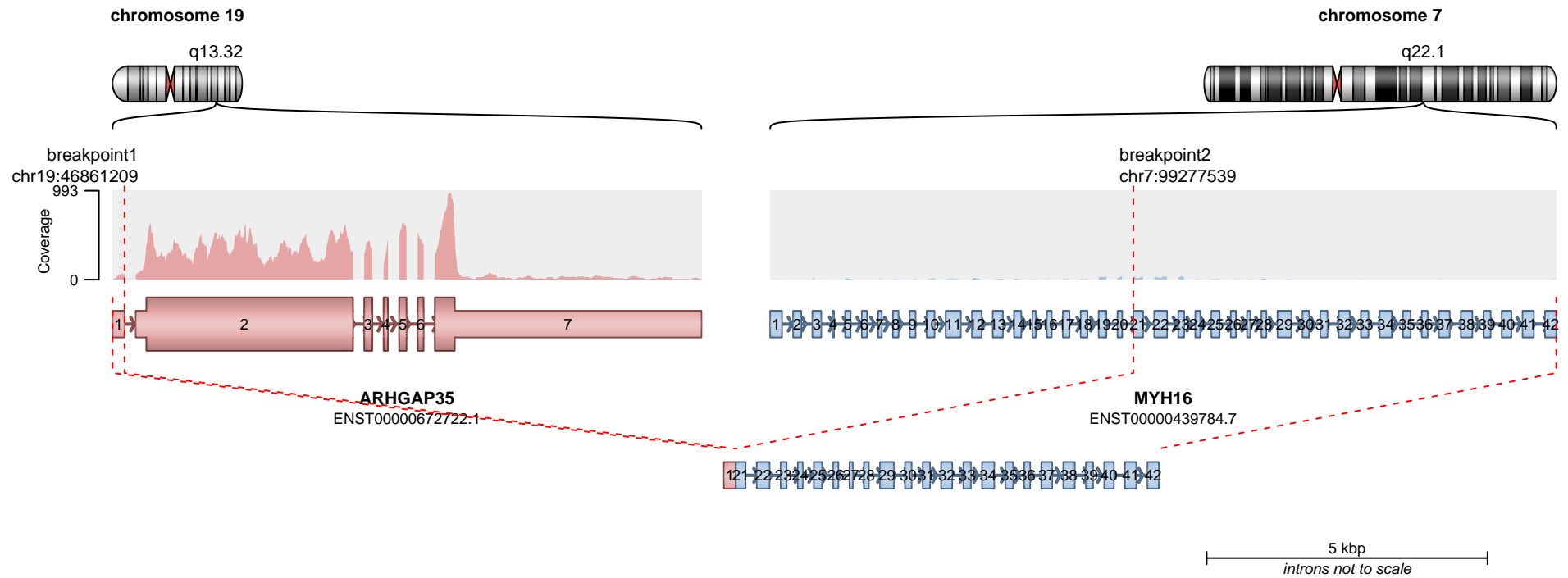

— translocation    — deletion  
— duplication    — inversion

No coding regions retained in fusion transcript.

**SUPPORTING READ COUNT**

Split reads = 1  
Discordant mates = 0

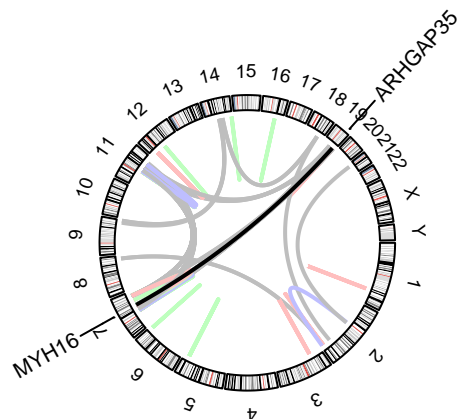
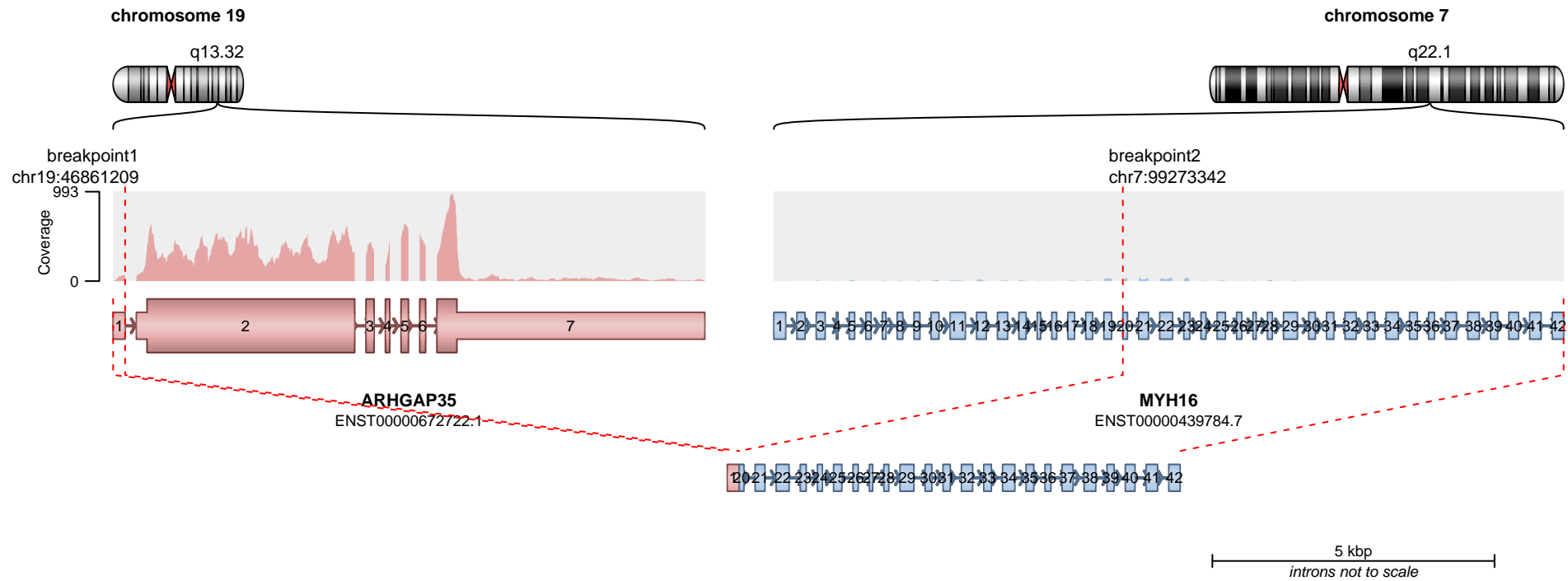

— translocation  
— duplication  
— deletion  
— inversion

No coding regions retained in fusion transcript.

**SUPPORTING READ COUNT**

Split reads = 1  
Discordant mates = 0

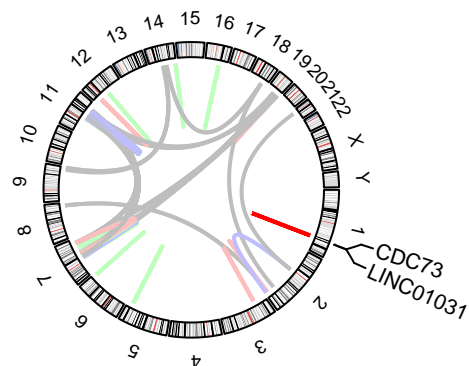
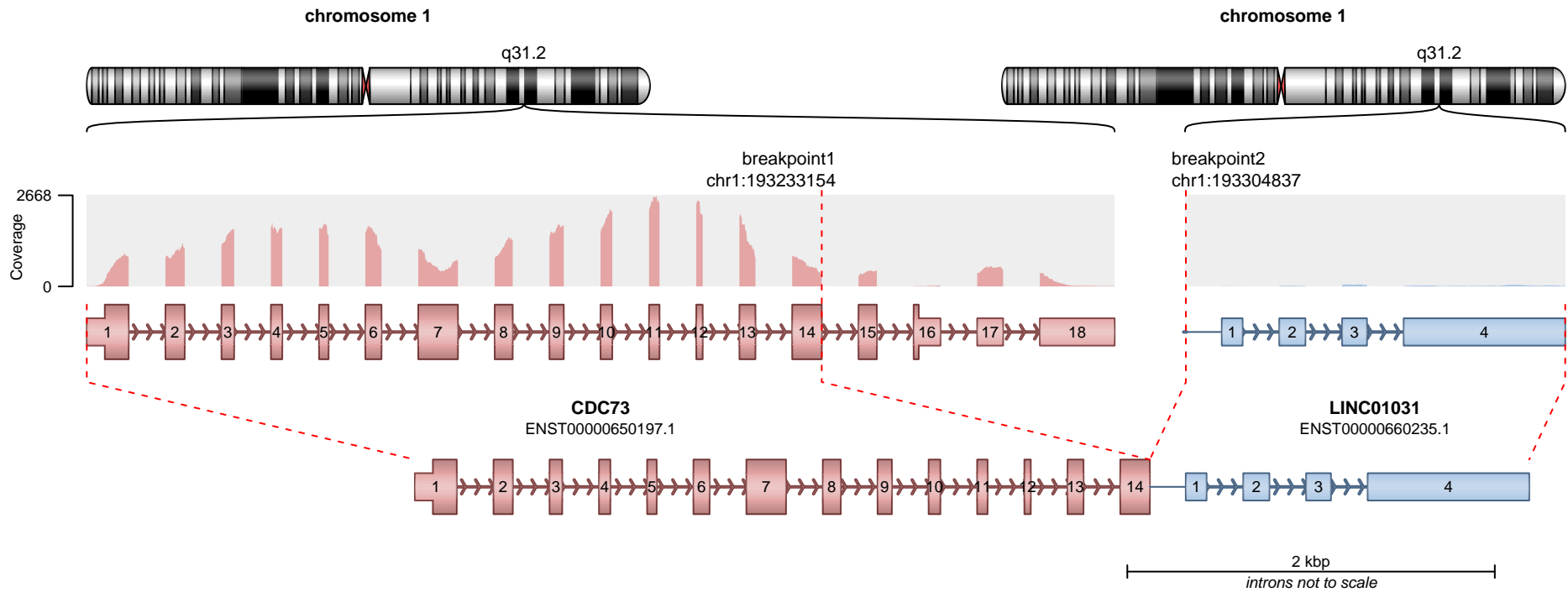

**RETAINED PROTEIN DOMAINS**  
reading frame unclear

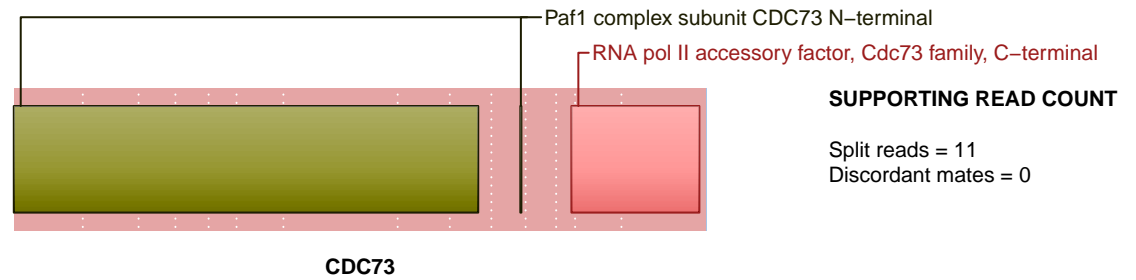

- translocation
- duplication
- deletion
- inversion

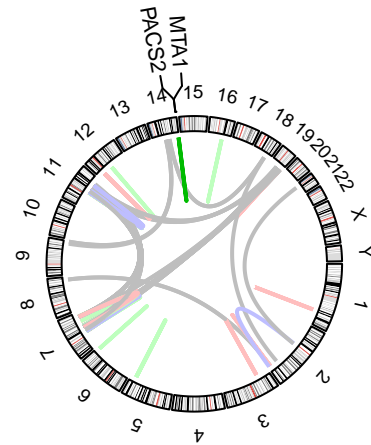
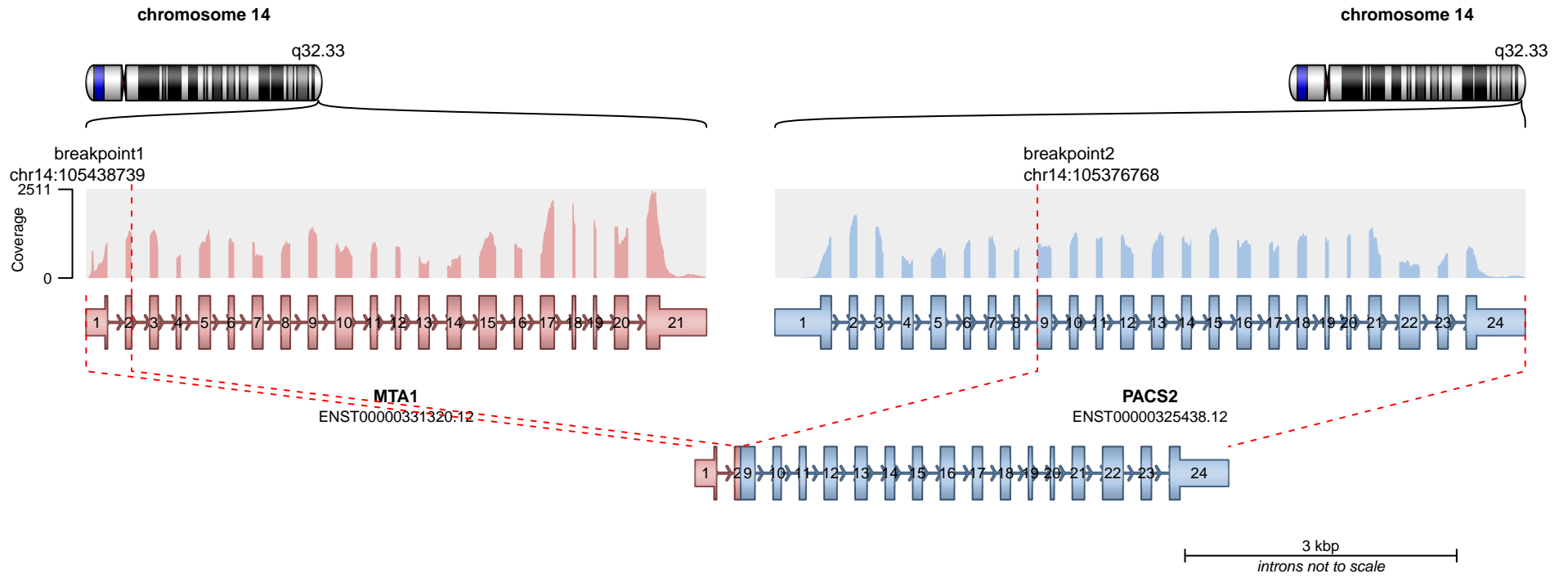

**RETAINED PROTEIN DOMAINS**  
reading frame unclear

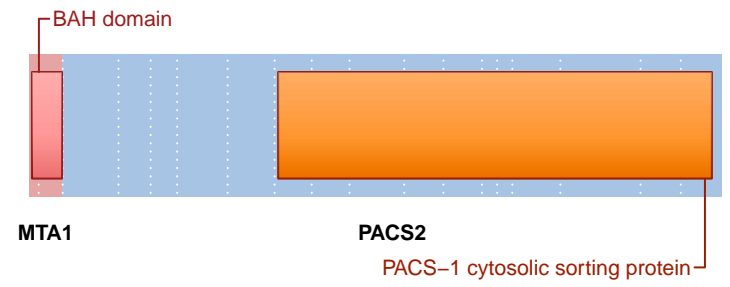

**SUPPORTING READ COUNT**

Split reads = 11  
Discordant mates = 0

- translocation
- duplication
- deletion
- inversion

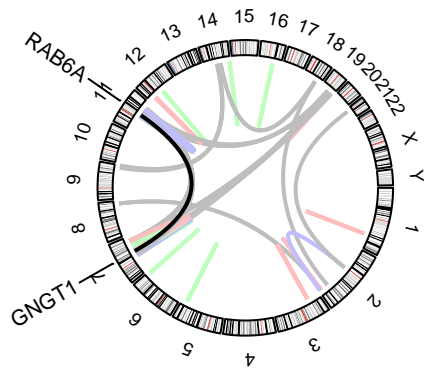
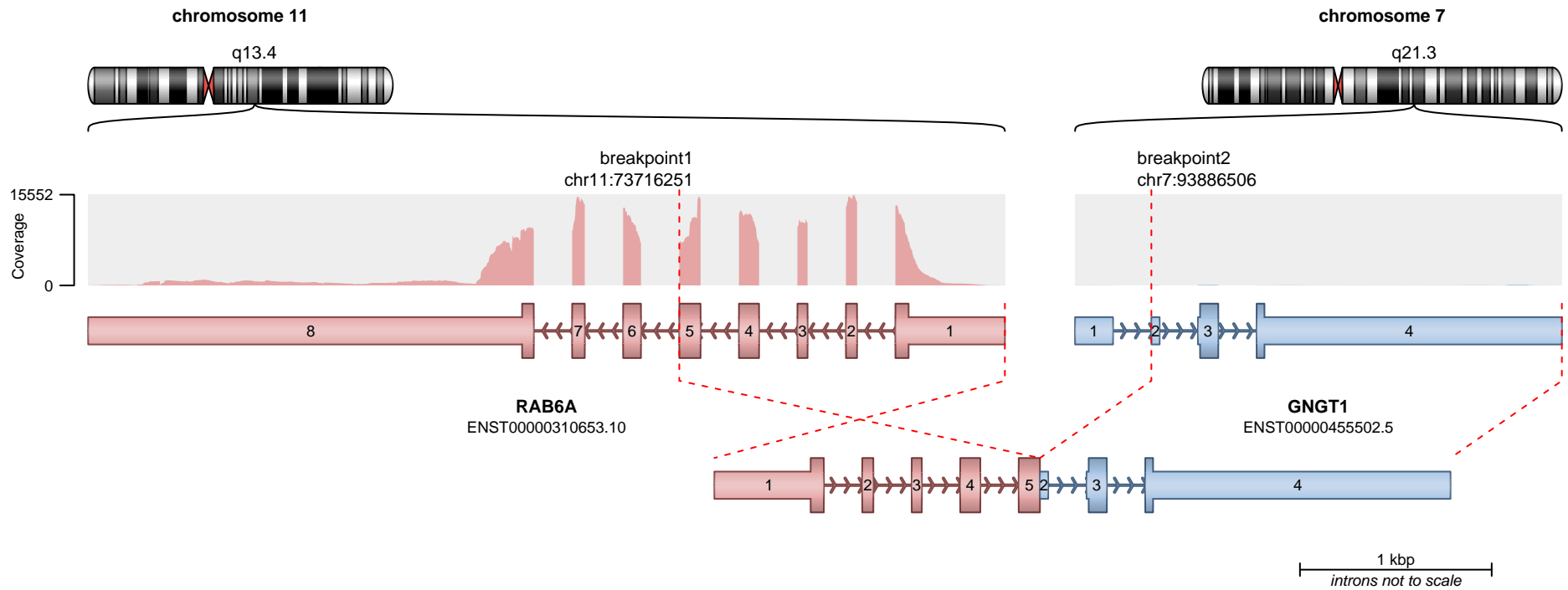

**RETAINED PROTEIN DOMAINS**  
reading frame unclear

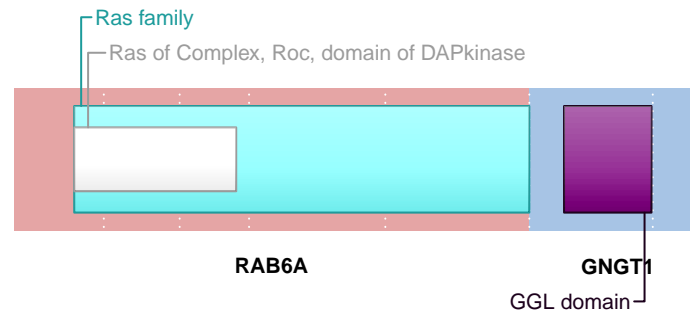

**SUPPORTING READ COUNT**

Split reads = 10  
Discordant mates = 1

— translocation    — deletion  
— duplication    — inversion

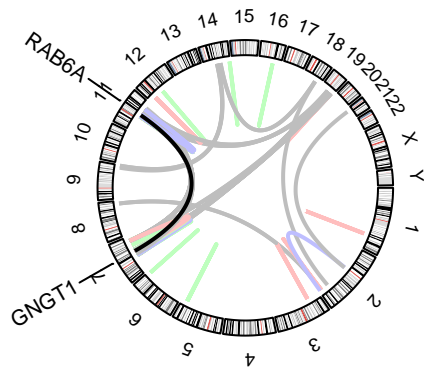
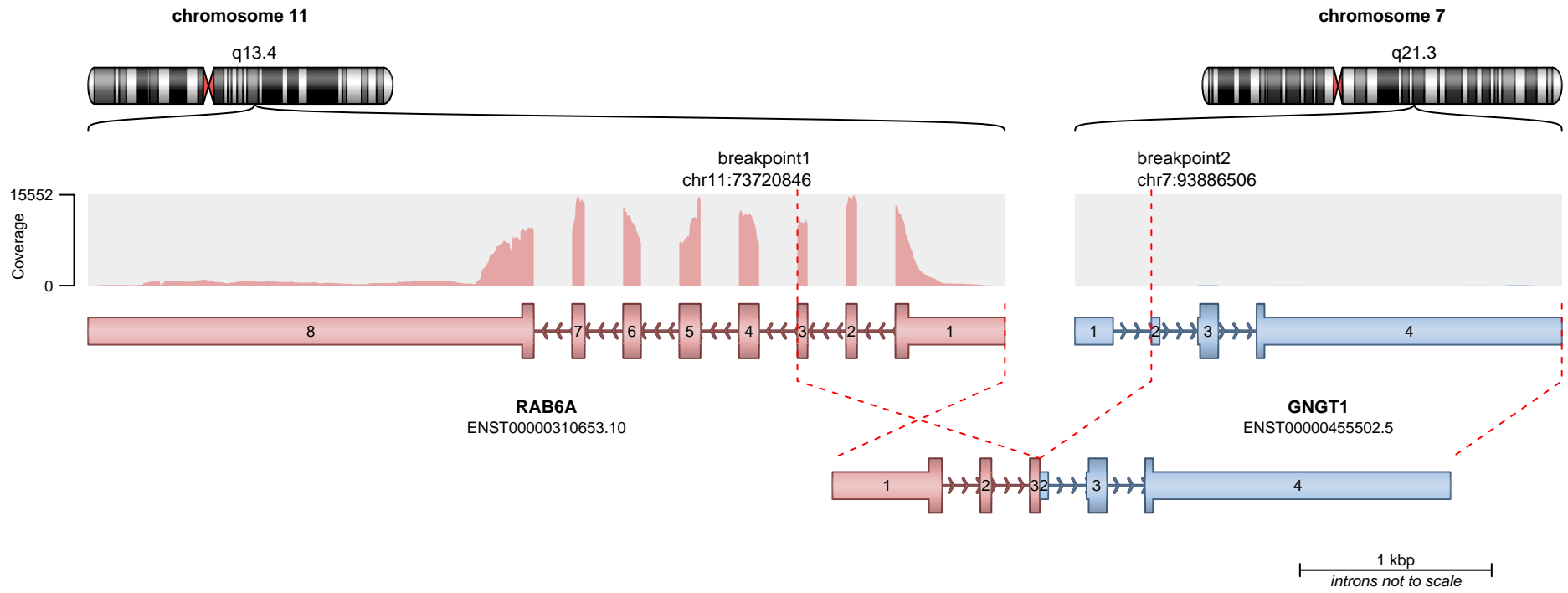

**RETAINED PROTEIN DOMAINS**  
reading frame unclear

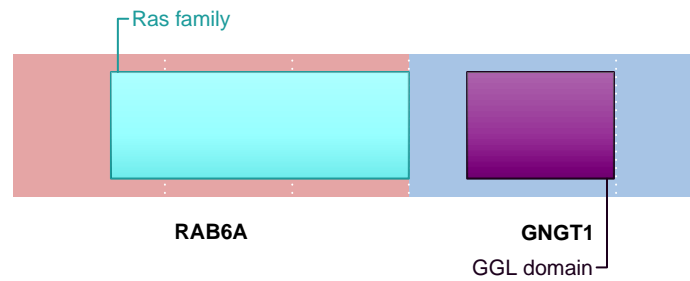

**SUPPORTING READ COUNT**

Split reads = 1  
Discordant mates = 0

— translocation    — deletion  
— duplication    — inversion

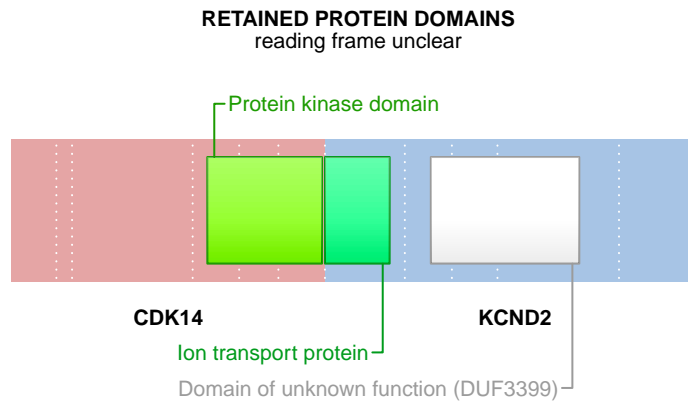
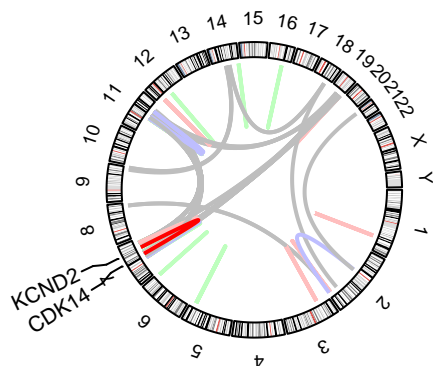
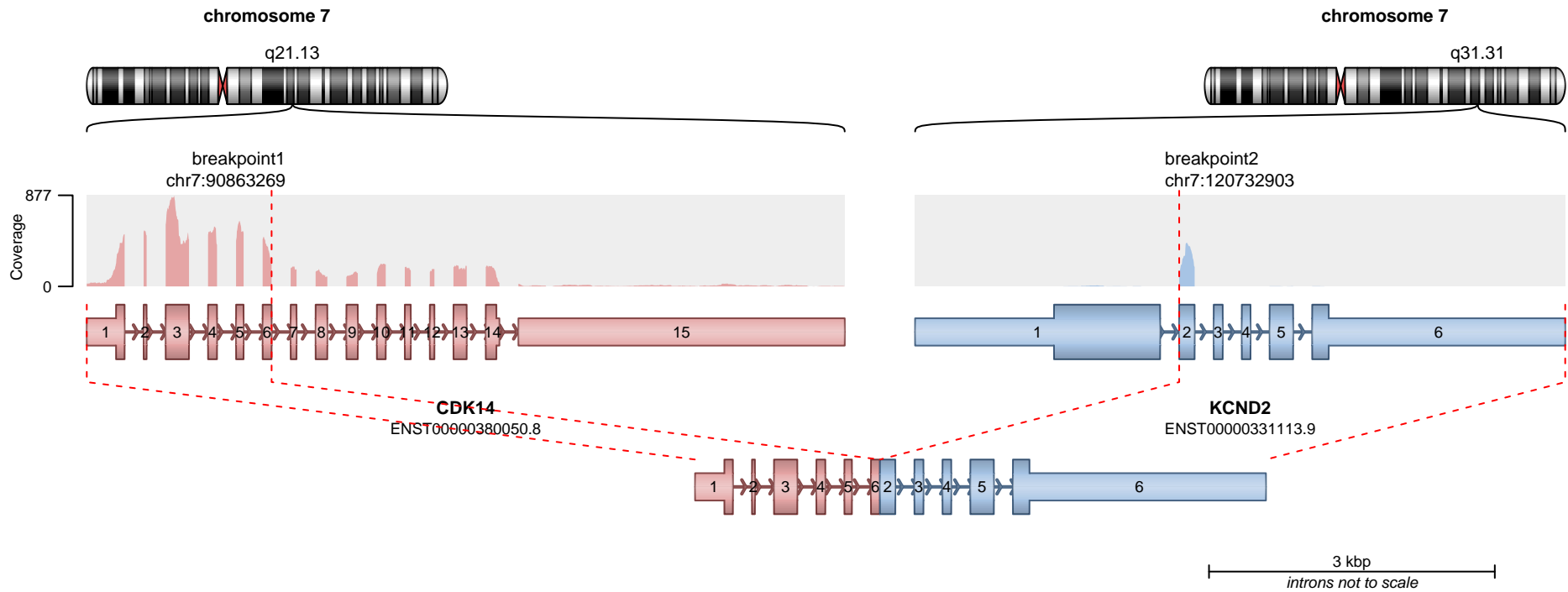

**SUPPORTING READ COUNT**

Split reads = 10  
Discordant mates = 0

- translocation
- duplication
- deletion
- inversion

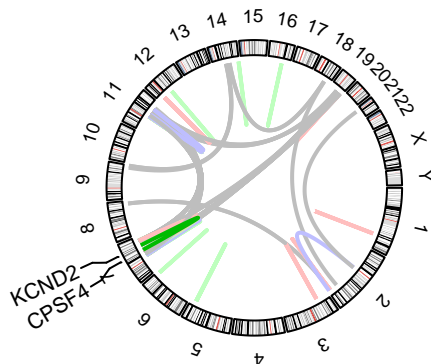
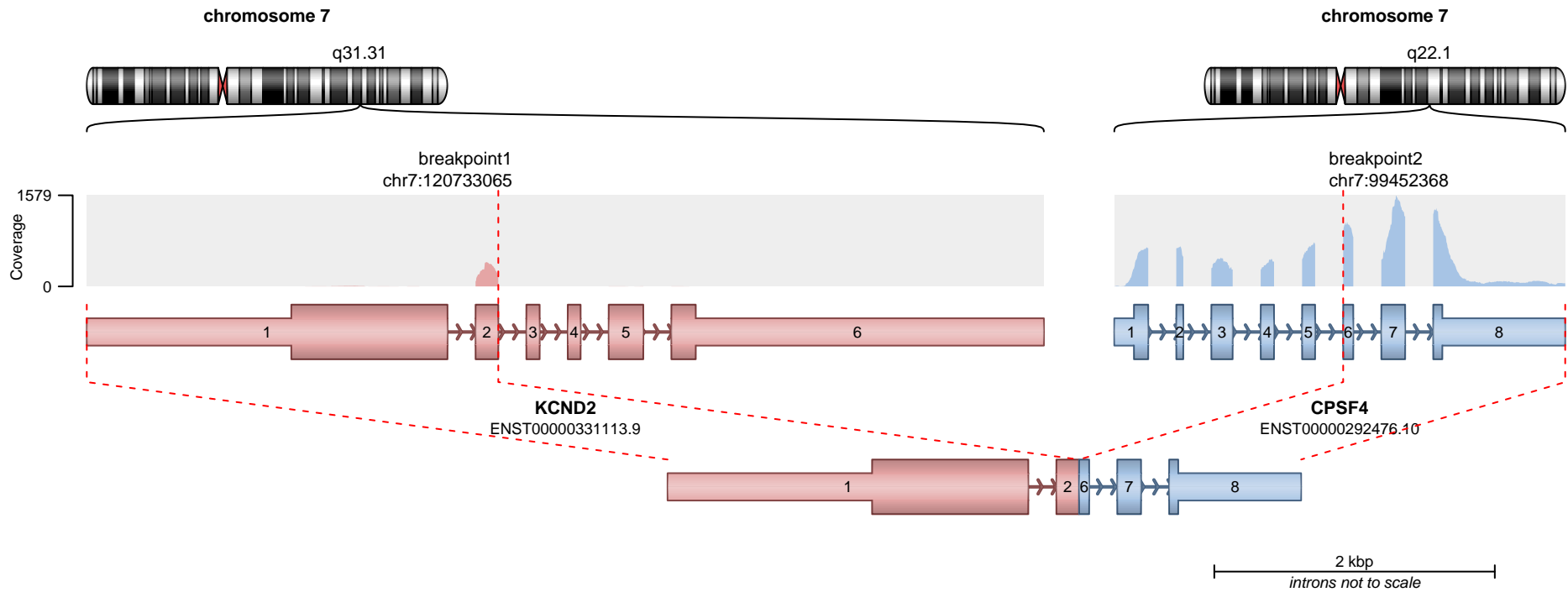

**RETAINED PROTEIN DOMAINS**  
reading frame unclear

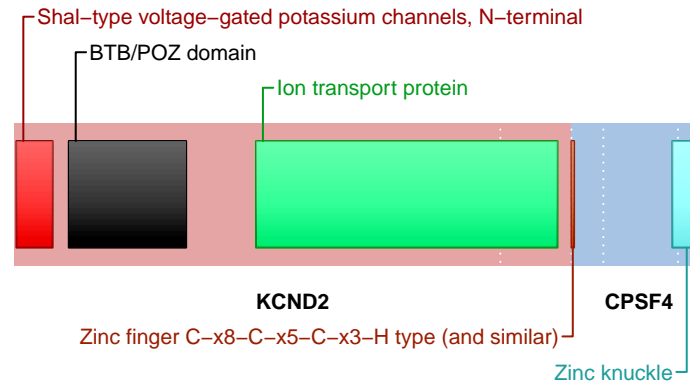

**SUPPORTING READ COUNT**

Split reads = 10  
Discordant mates = 0

— translocation — deletion  
— duplication — inversion

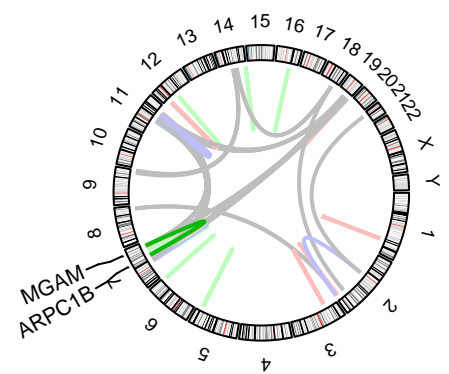
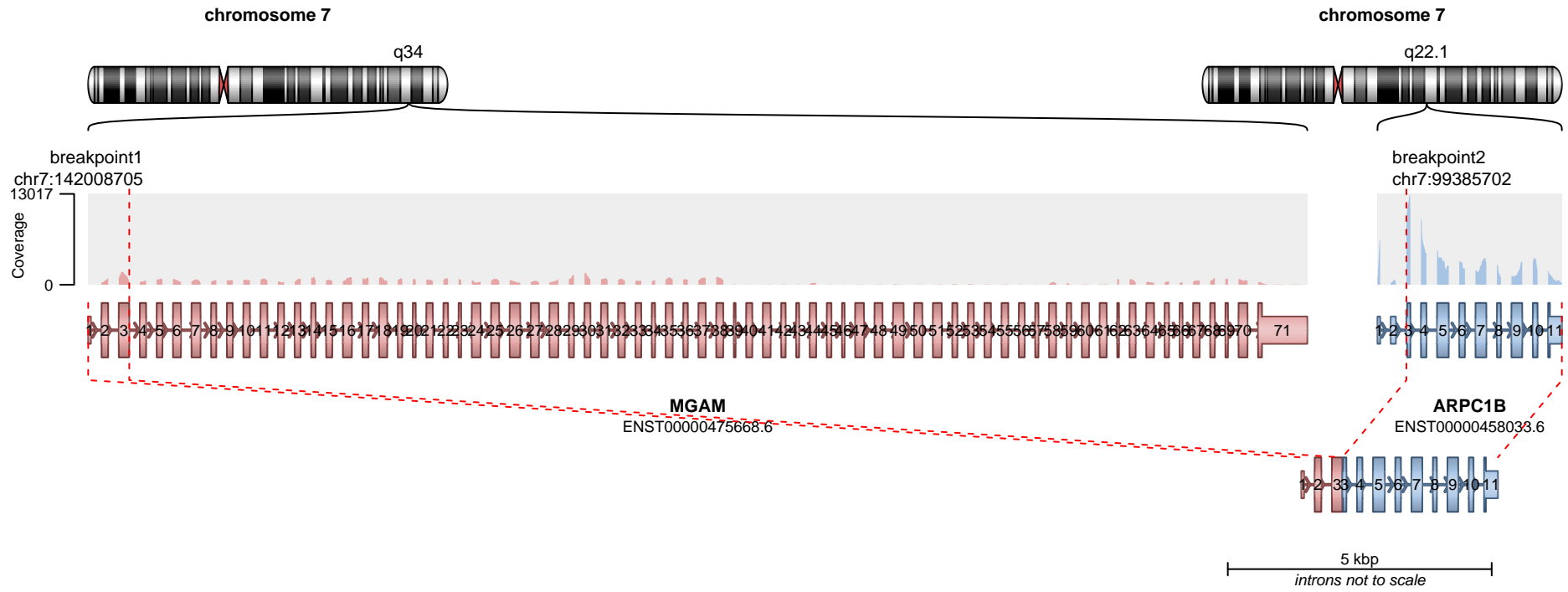

**RETAINED PROTEIN DOMAINS**  
reading frame unclear

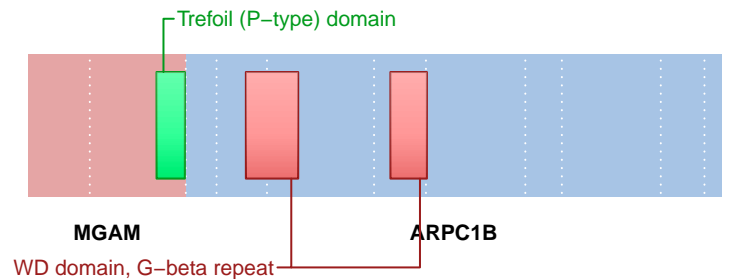

**SUPPORTING READ COUNT**

Split reads = 10  
Discordant mates = 0

- translocation
- duplication
- deletion
- inversion

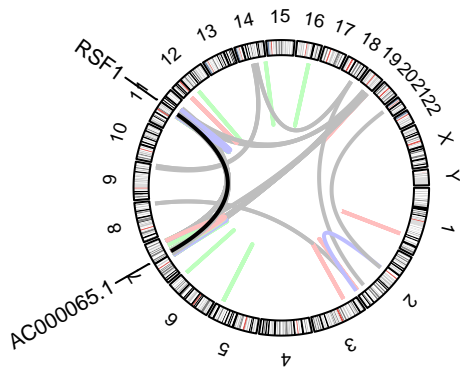
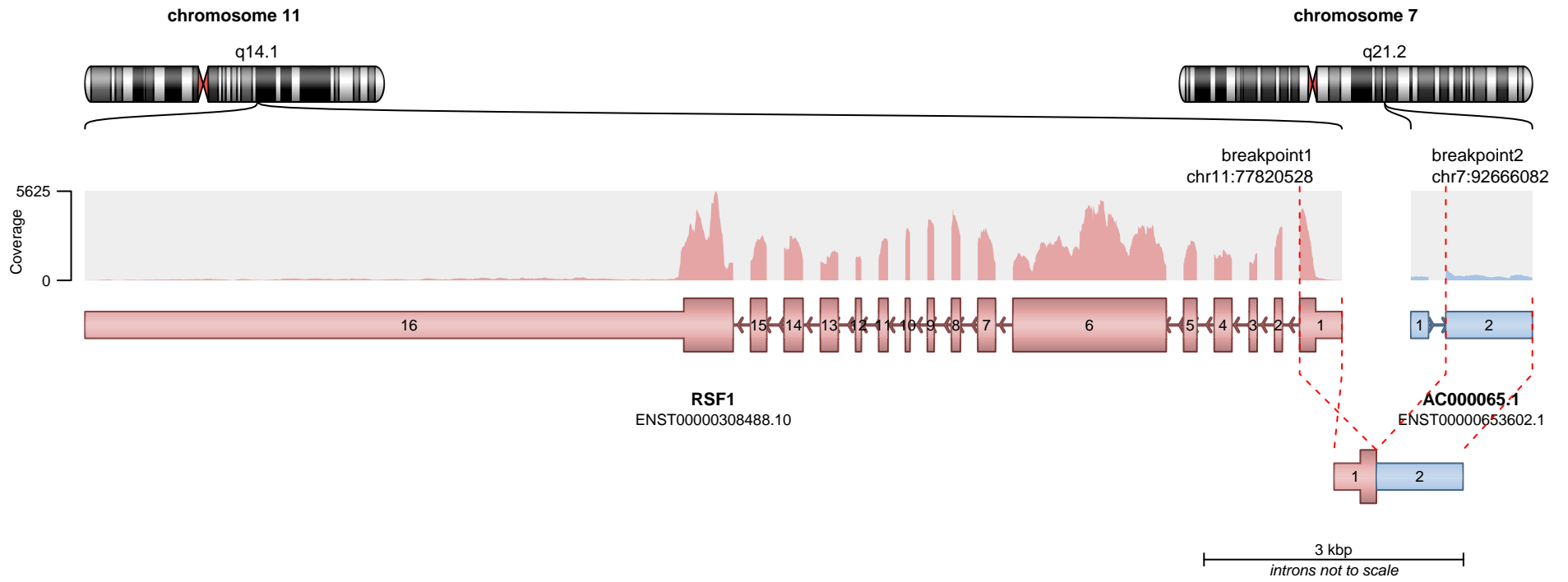

— translocation    — deletion  
 — duplication    — inversion

No protein domains retained in fusion.

**SUPPORTING READ COUNT**

Split reads = 9  
Discordant mates = 0

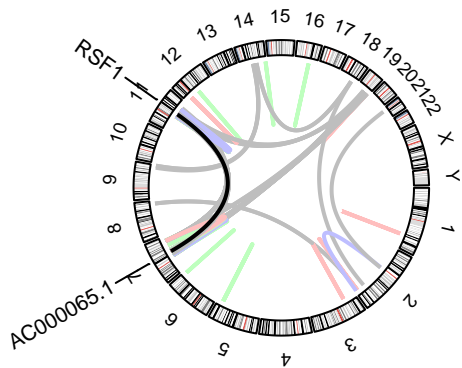
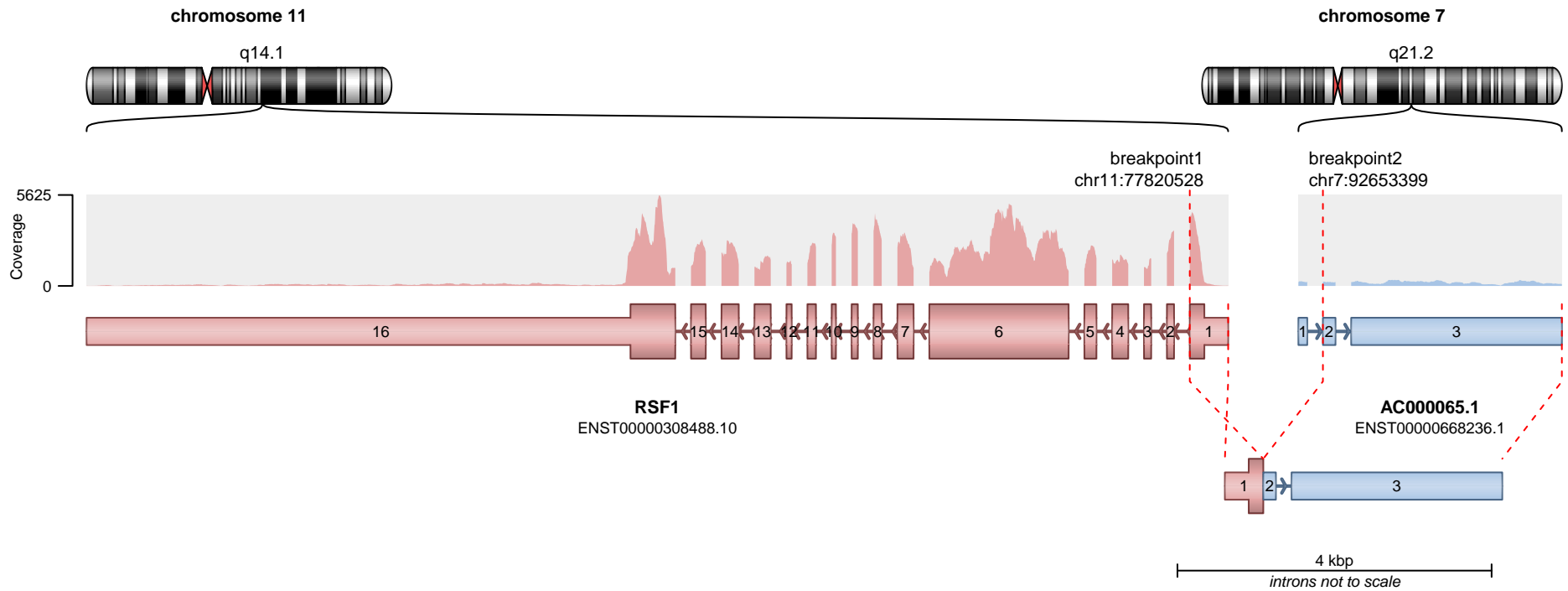

— translocation    — deletion  
 — duplication    — inversion

No protein domains retained in fusion.

**SUPPORTING READ COUNT**

Split reads = 1  
 Discordant mates = 0

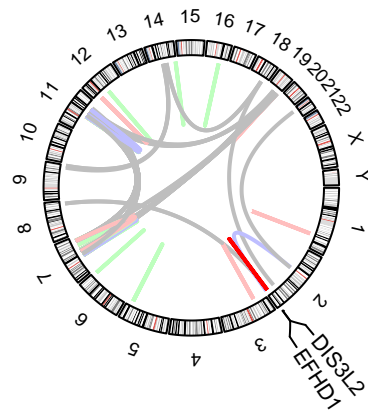
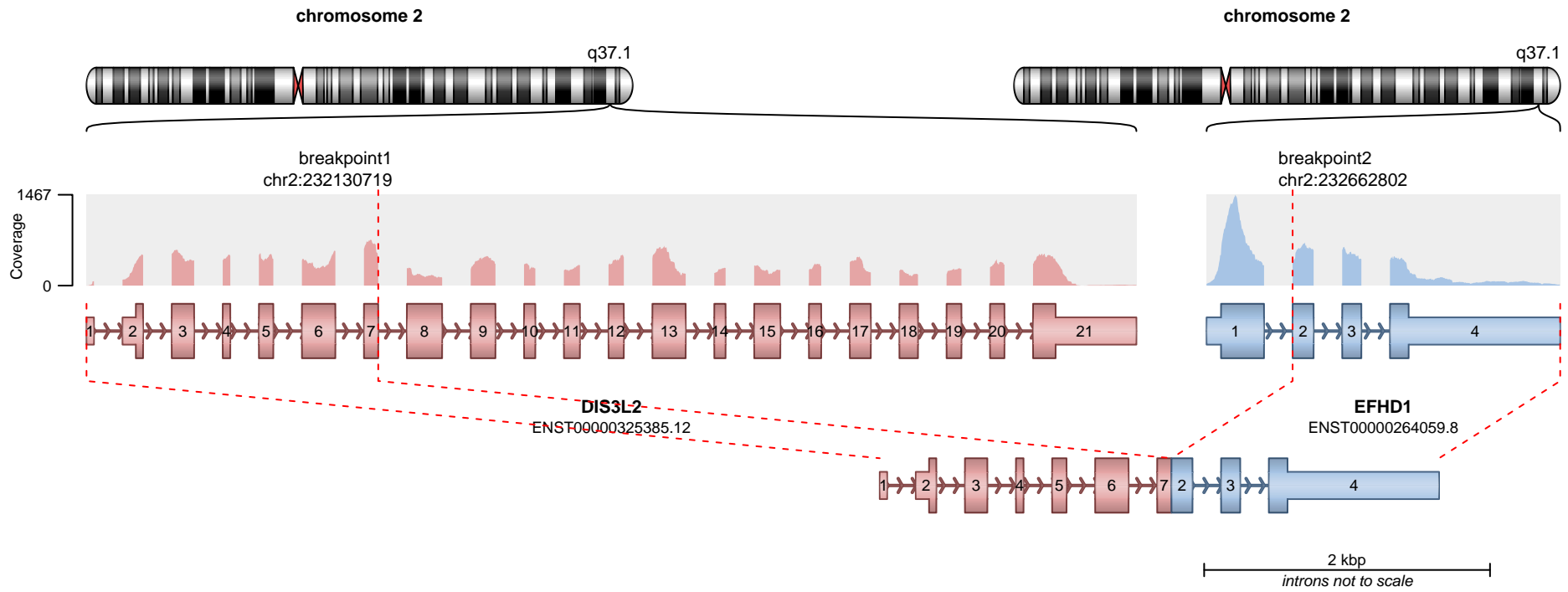

**RETAINED PROTEIN DOMAINS**  
reading frame unclear

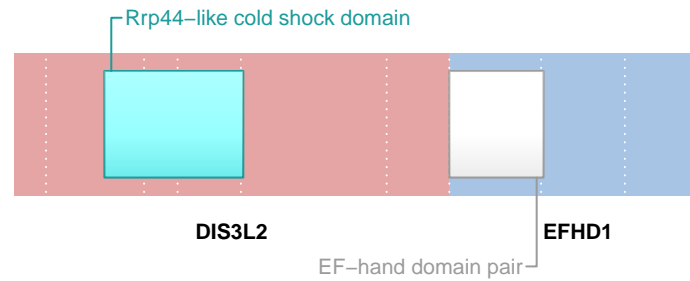

**SUPPORTING READ COUNT**

Split reads = 7  
Discordant mates = 0

- translocation
- duplication
- deletion
- inversion

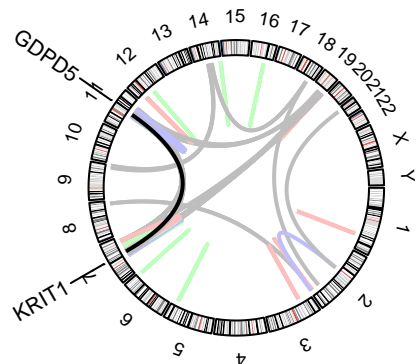
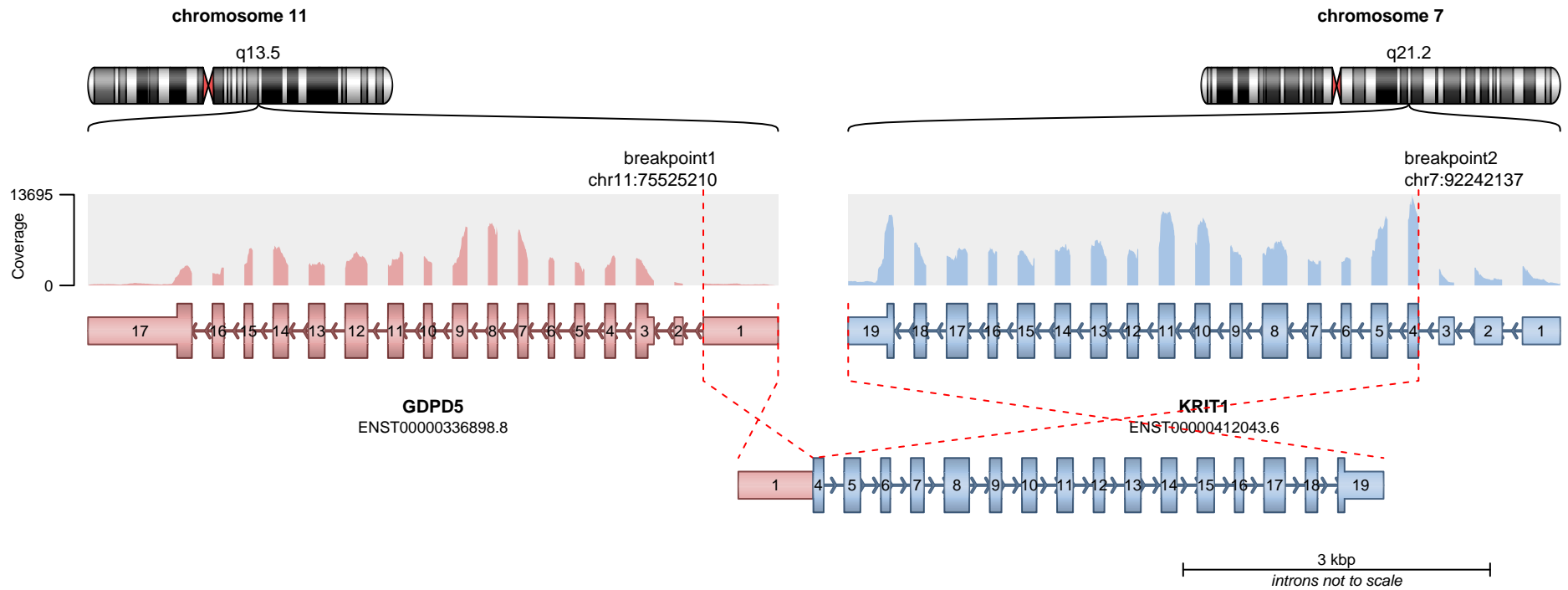

NUDIX, or N-terminal NPxY motif-rich, region of KRIT1

Ankyrin repeats (many copies)

FERM central domain

**RETAINED PROTEIN DOMAINS**  
reading frame unclear

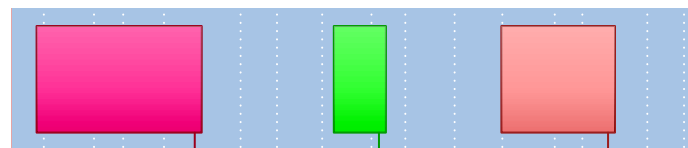

**SUPPORTING READ COUNT**

Split reads = 7  
Discordant mates = 0

— translocation    — deletion  
— duplication    — inversion

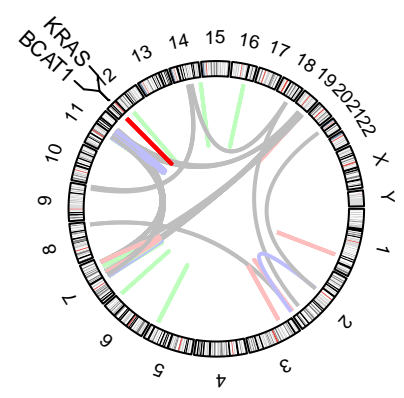
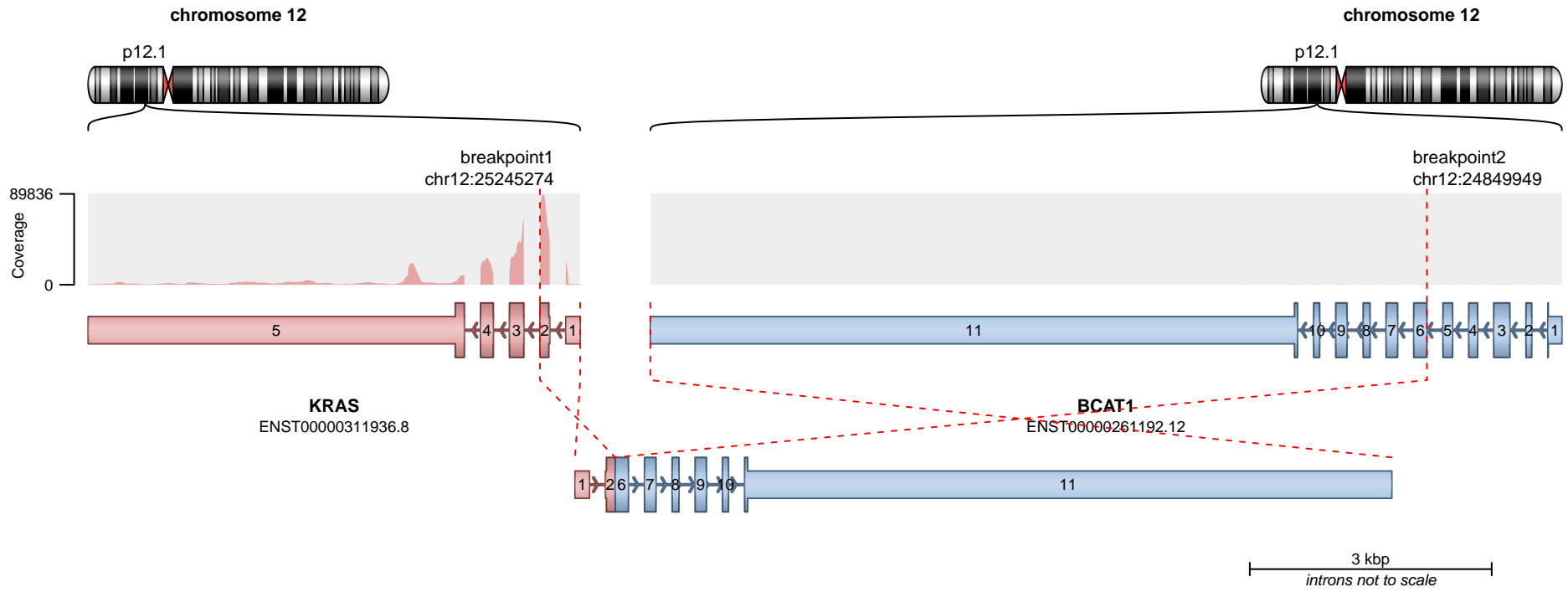

**RETAINED PROTEIN DOMAINS**  
reading frame unclear

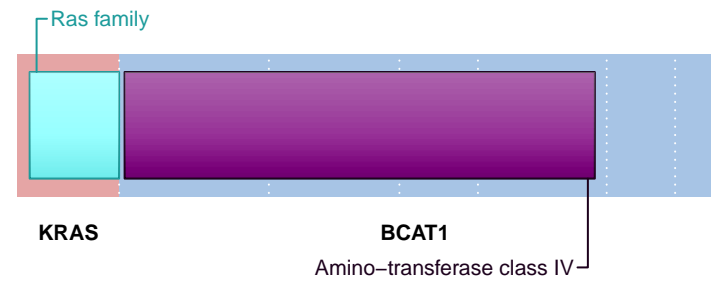

**SUPPORTING READ COUNT**

Split reads = 7  
Discordant mates = 0

- translocation
- duplication
- deletion
- inversion

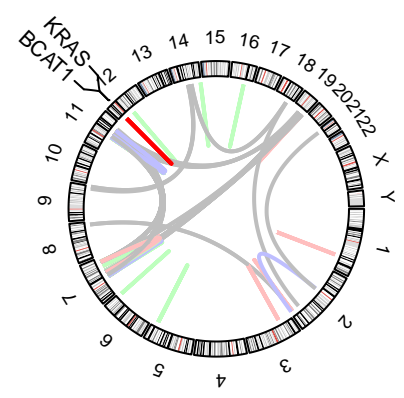
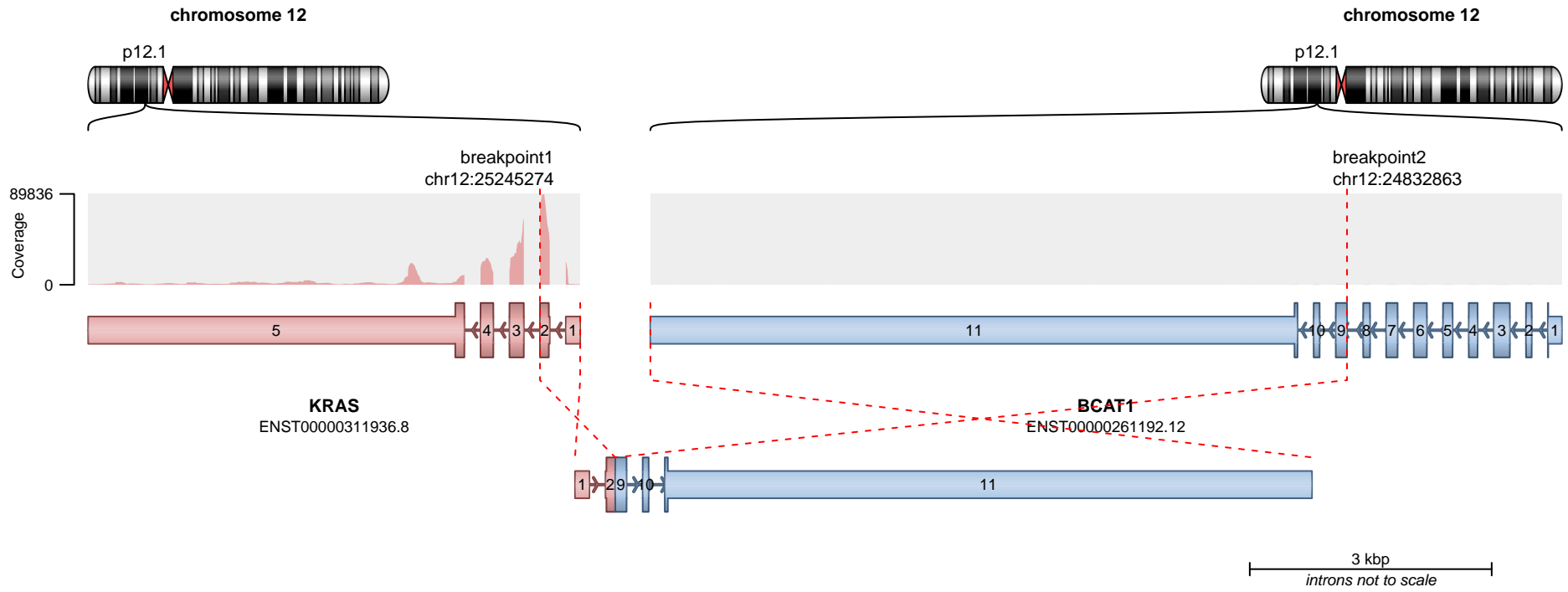

**RETAINED PROTEIN DOMAINS**  
reading frame unclear

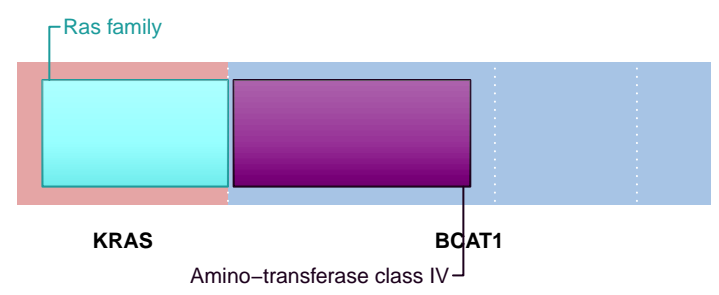

**SUPPORTING READ COUNT**

Split reads = 4  
Discordant mates = 0

- translocation
- duplication
- deletion
- inversion

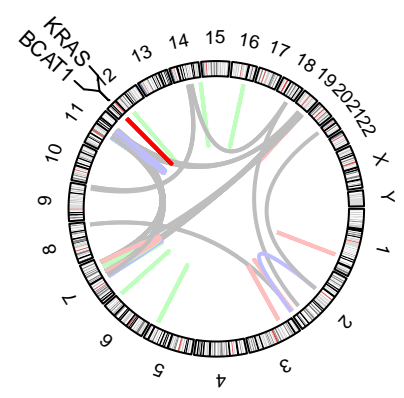
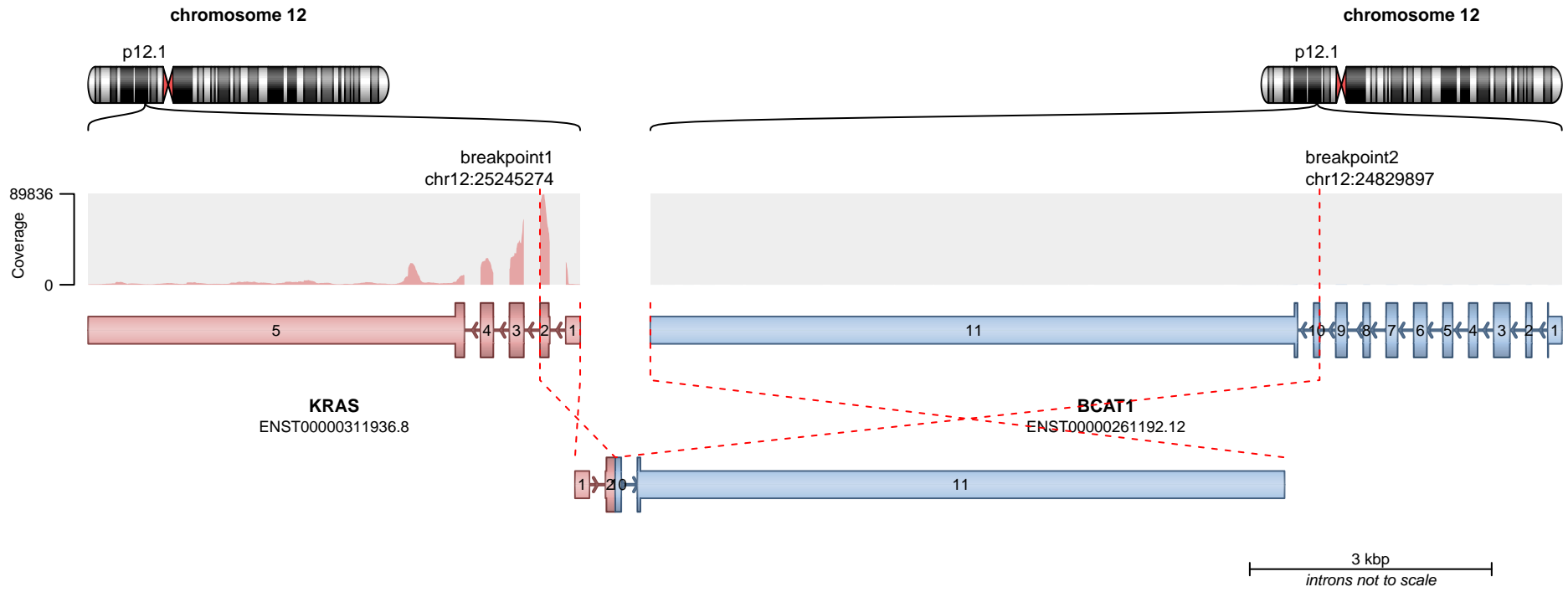

**RETAINED PROTEIN DOMAINS**  
reading frame unclear

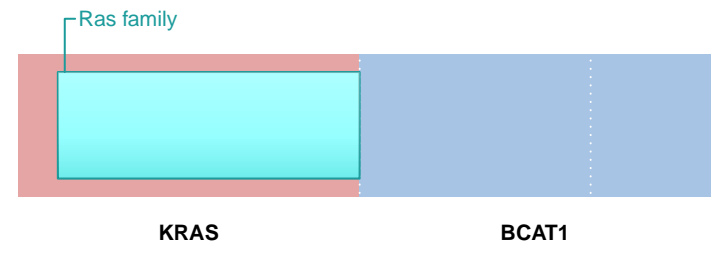

**SUPPORTING READ COUNT**

Split reads = 1  
Discordant mates = 0

- translocation
- duplication
- deletion
- inversion

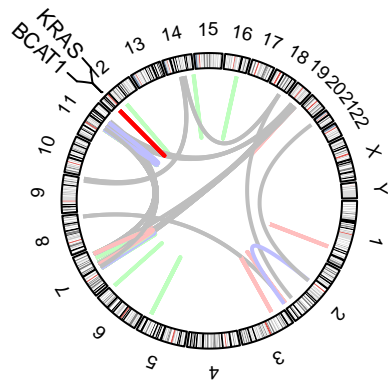
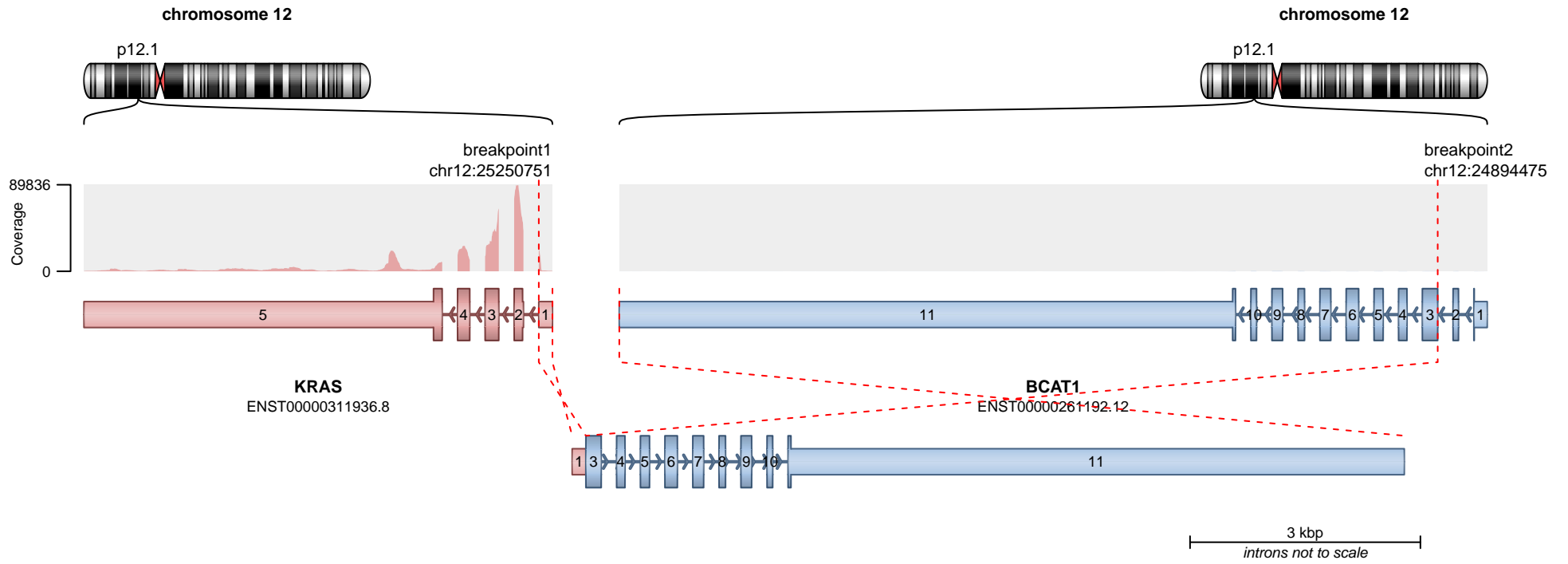

— translocation    — deletion  
— duplication    — inversion

**RETAINED PROTEIN DOMAINS**  
reading frame unclear

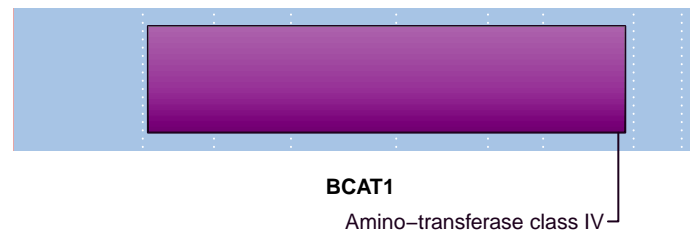

**SUPPORTING READ COUNT**

Split reads = 1  
Discordant mates = 0

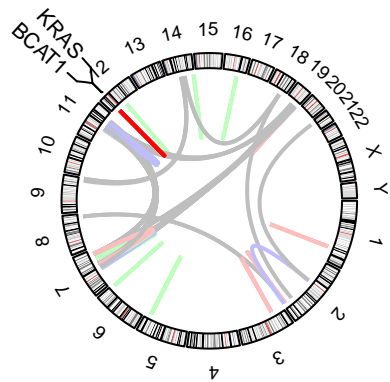
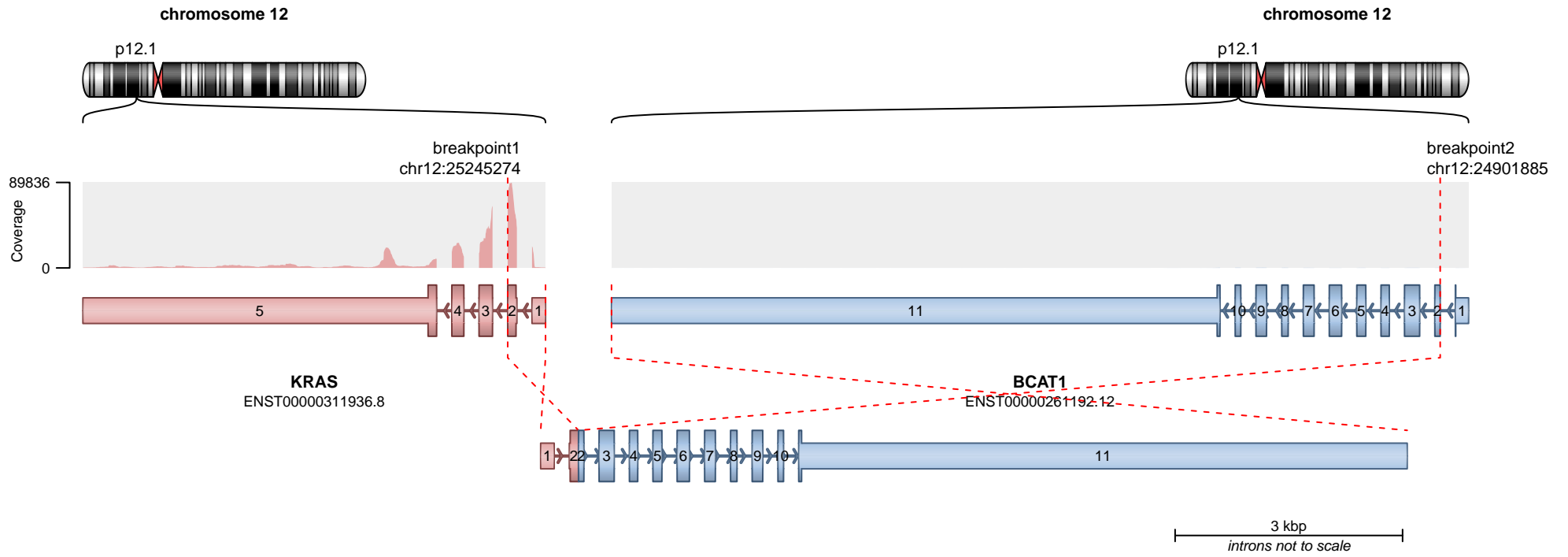

**RETAINED PROTEIN DOMAINS**  
reading frame unclear

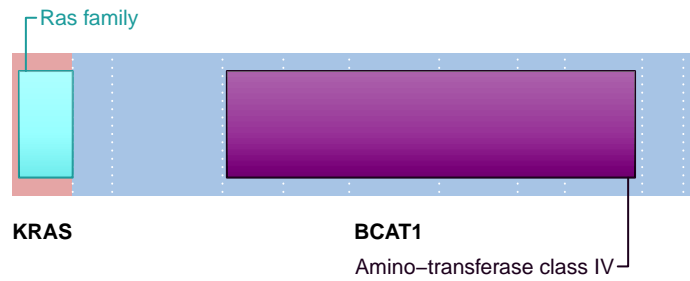

**SUPPORTING READ COUNT**

Split reads = 1  
Discordant mates = 0

- translocation
- duplication
- deletion
- inversion

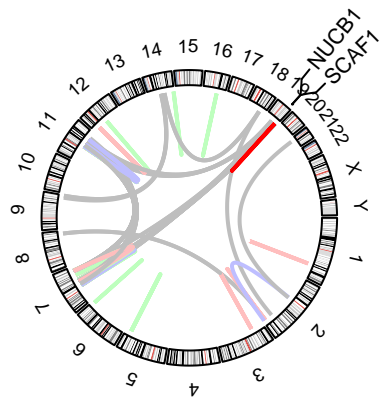
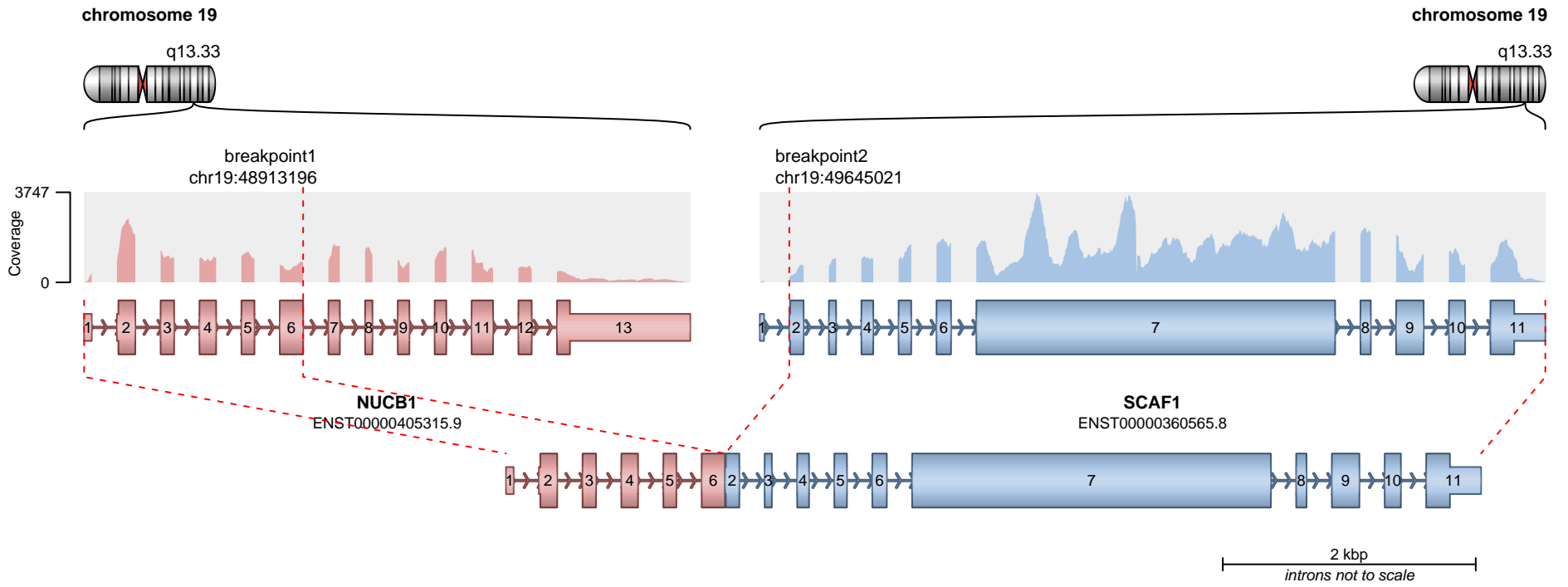

— translocation    — deletion  
— duplication    — inversion

No protein domains retained in fusion.

**SUPPORTING READ COUNT**

Split reads = 7  
Discordant mates = 0

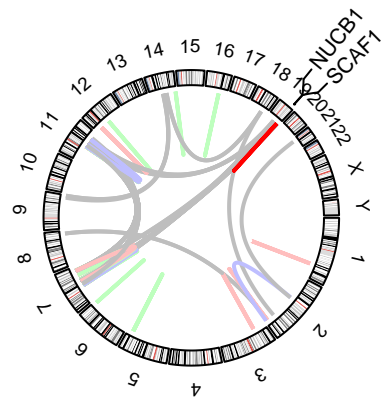
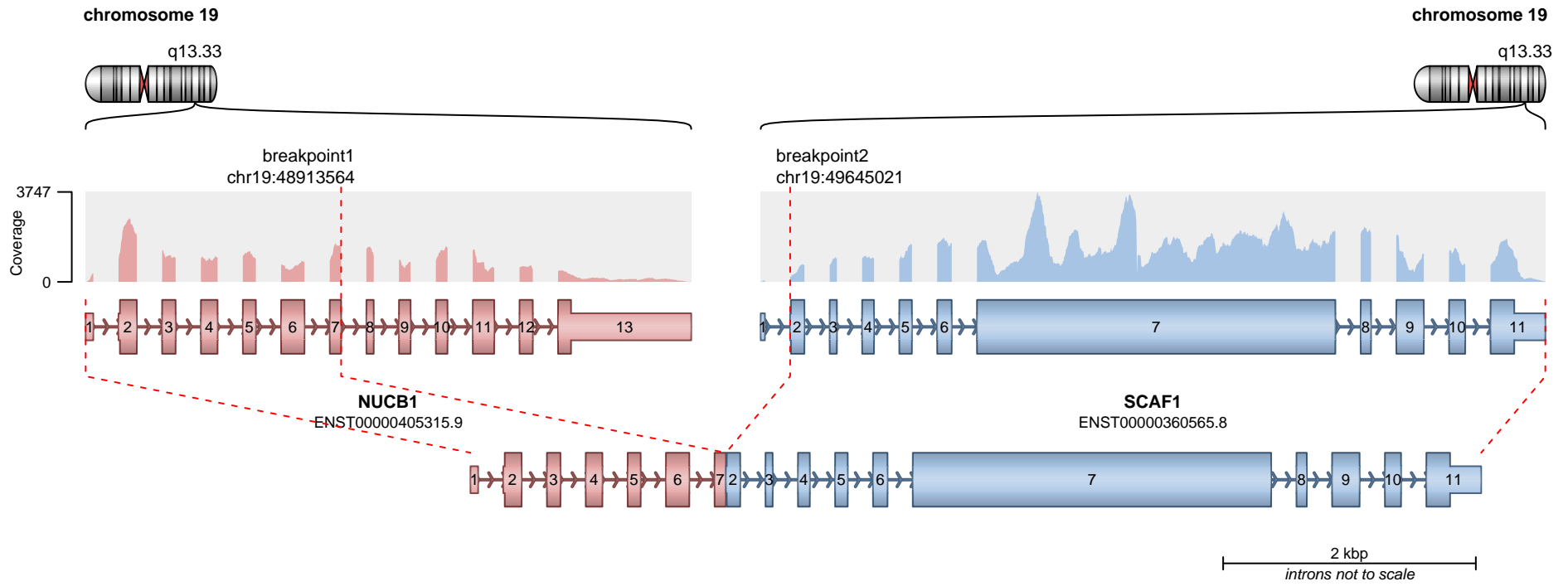

**RETAINED PROTEIN DOMAINS**  
reading frame unclear

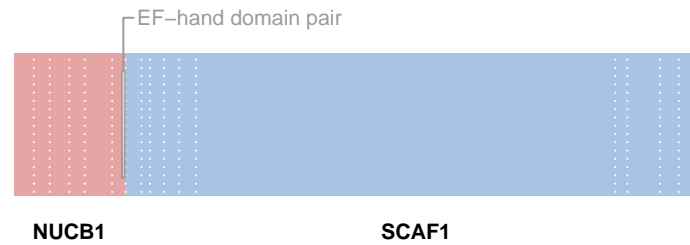

**SUPPORTING READ COUNT**

Split reads = 4  
Discordant mates = 0

- translocation
- duplication
- deletion
- inversion

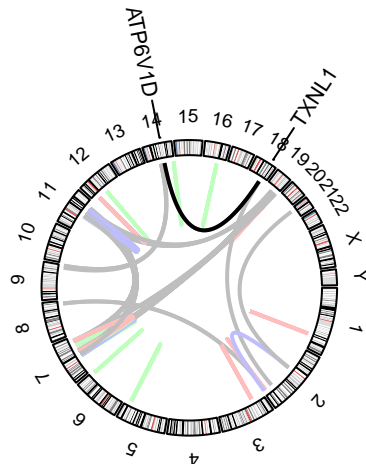
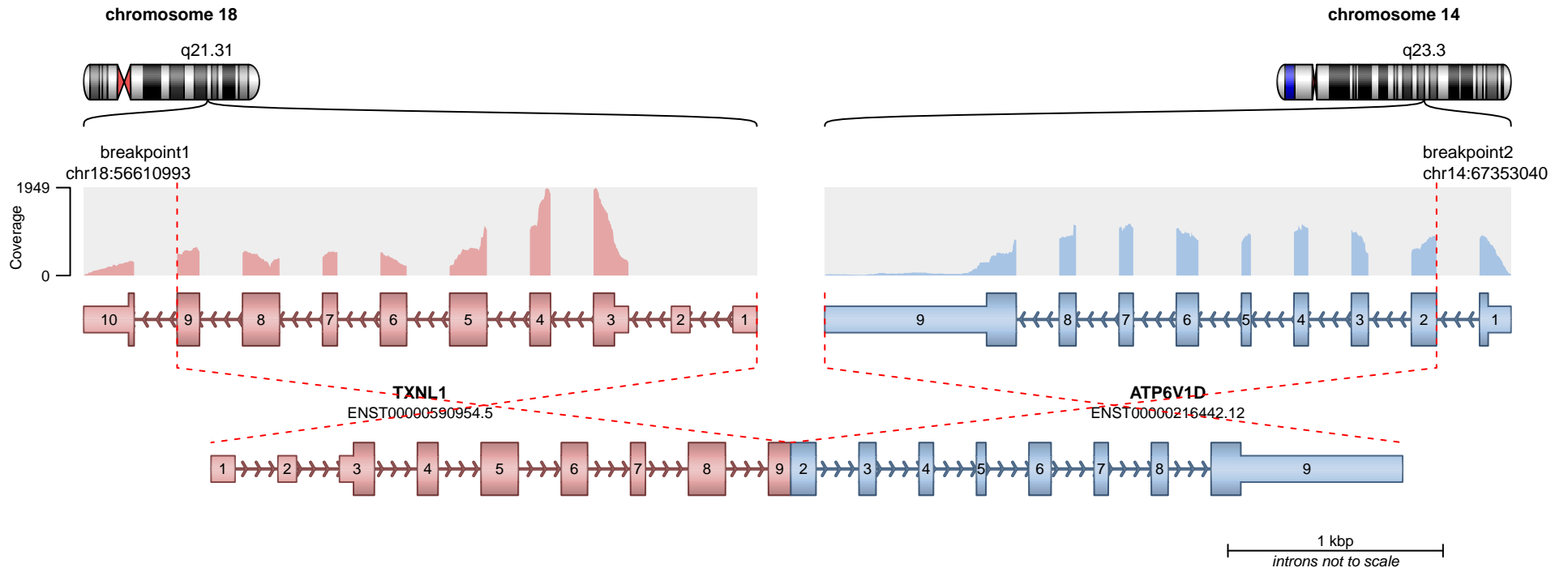

**RETAINED PROTEIN DOMAINS**  
reading frame unclear

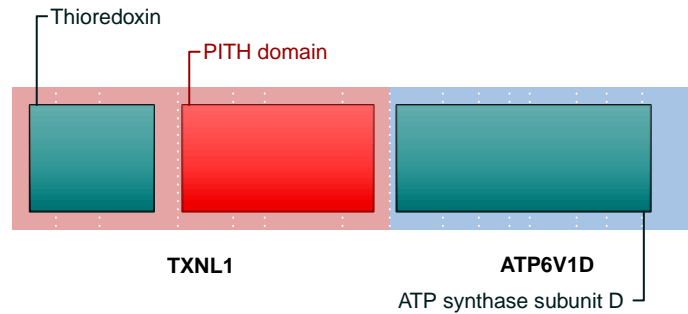

**SUPPORTING READ COUNT**

Split reads = 7  
Discordant mates = 0

— translocation    — deletion  
— duplication    — inversion

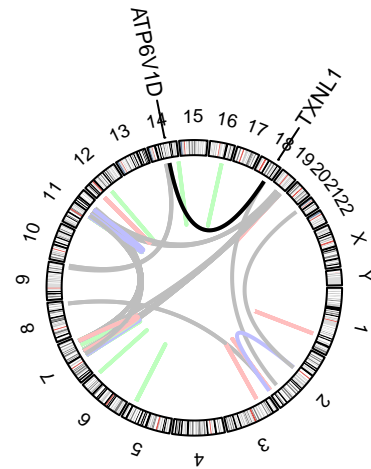
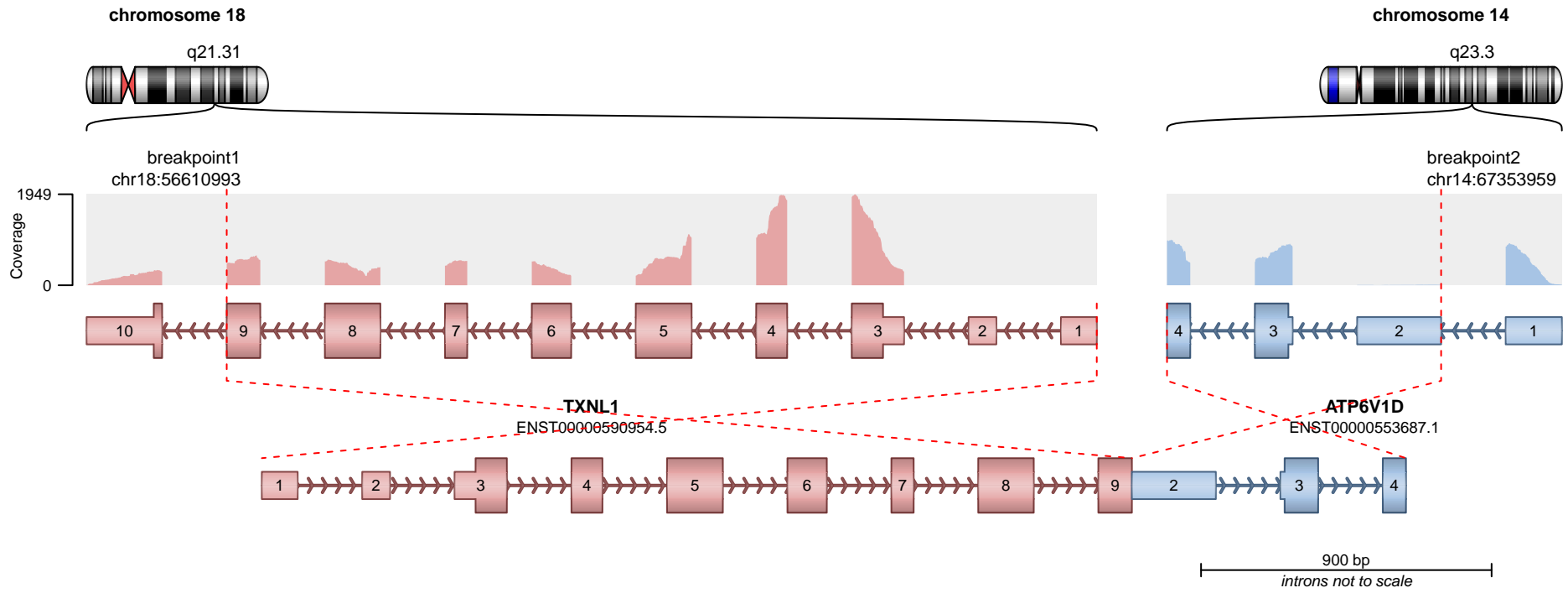

**RETAINED PROTEIN DOMAINS**  
reading frame unclear

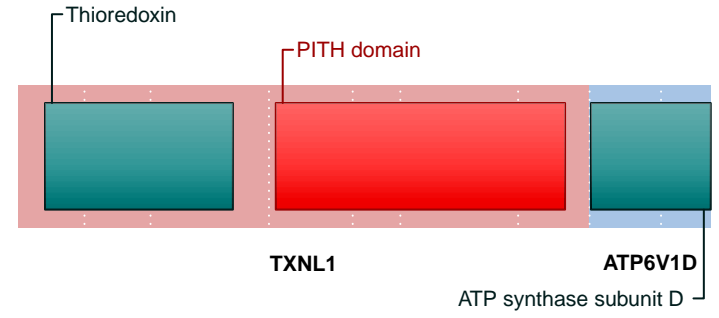

**SUPPORTING READ COUNT**

Split reads = 1  
Discordant mates = 0

- translocation
- duplication
- deletion
- inversion

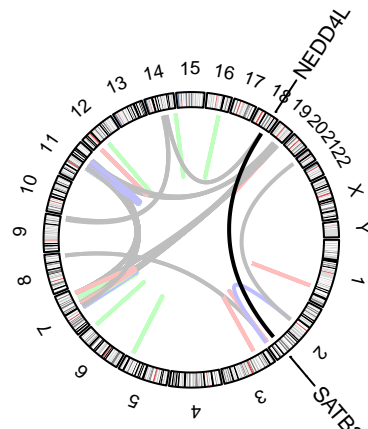
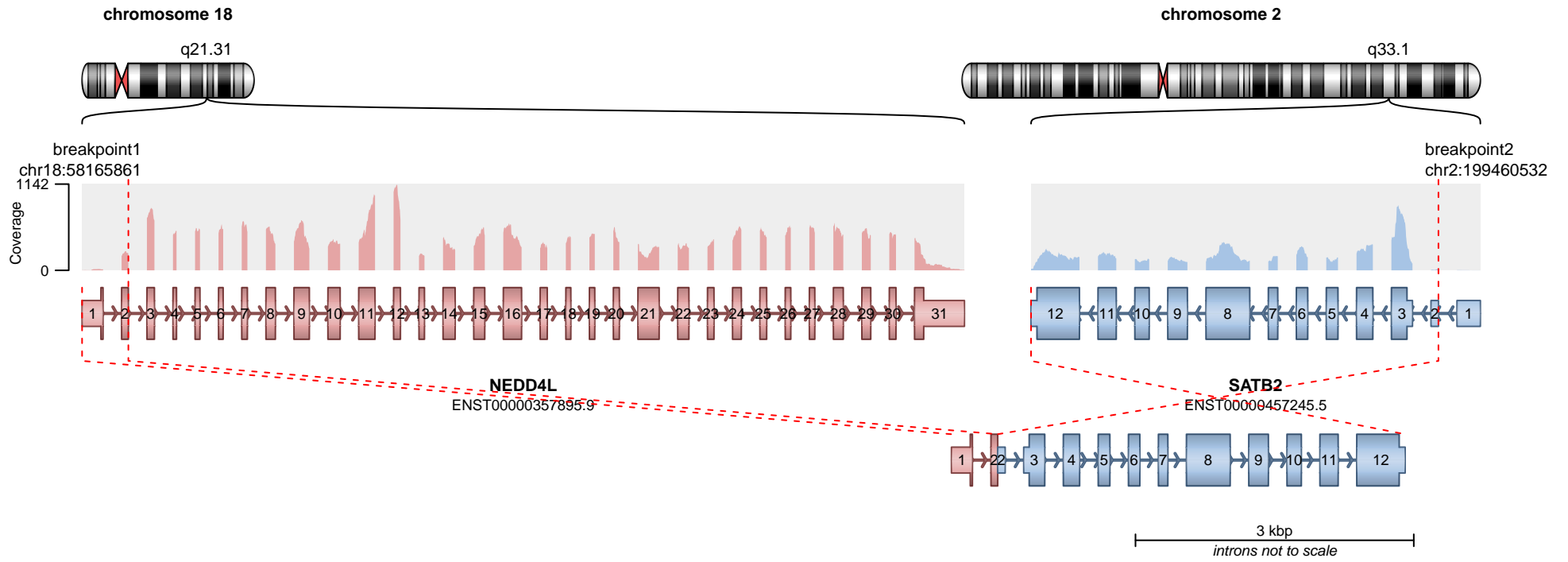

**RETAINED PROTEIN DOMAINS**  
reading frame unclear

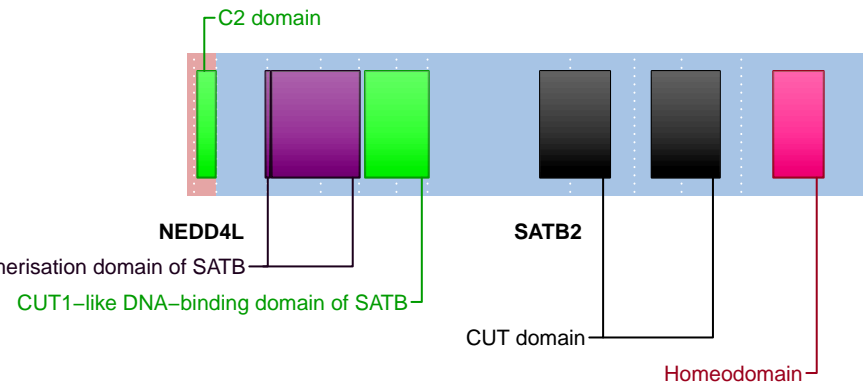

**SUPPORTING READ COUNT**

Split reads = 6  
Discordant mates = 0

- translocation
- duplication
- deletion
- inversion

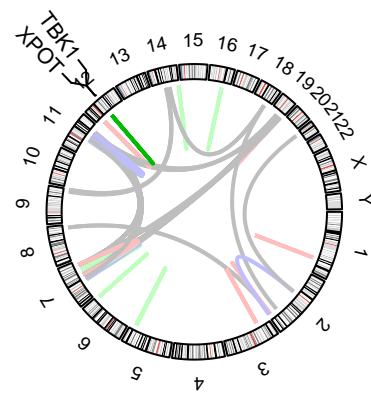
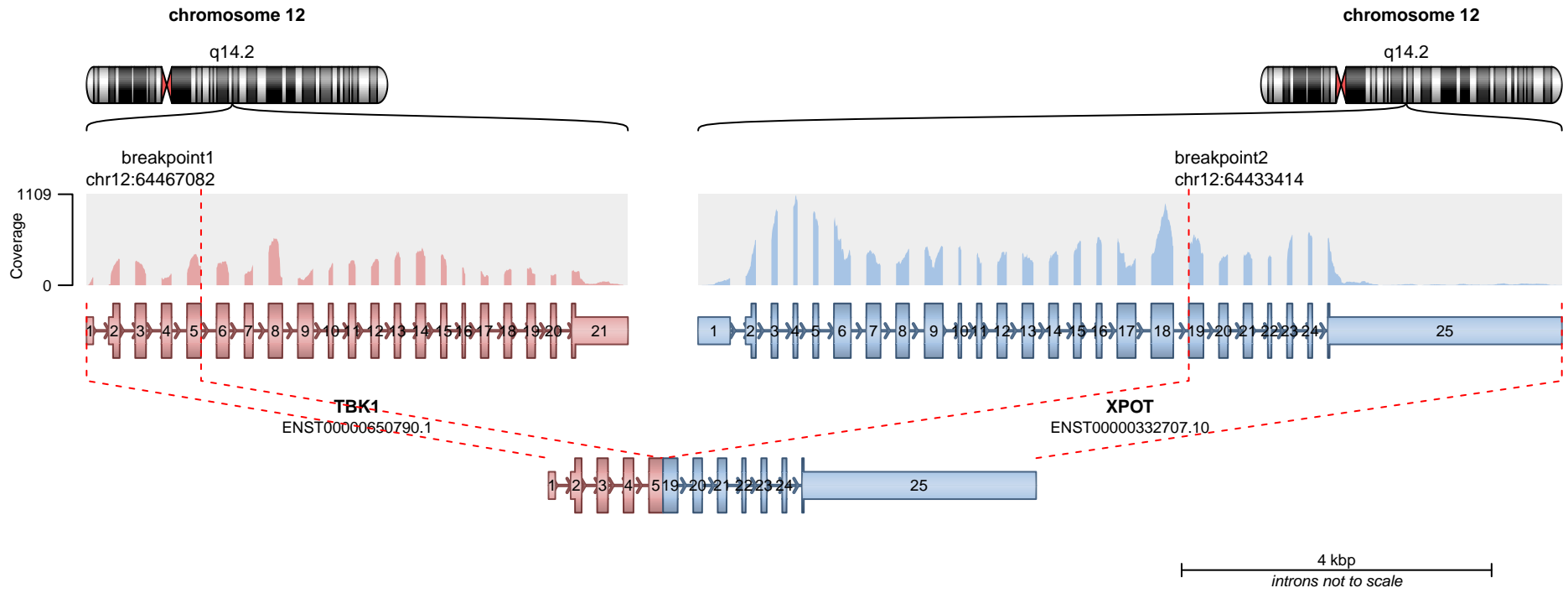

**RETAINED PROTEIN DOMAINS**  
reading frame unclear

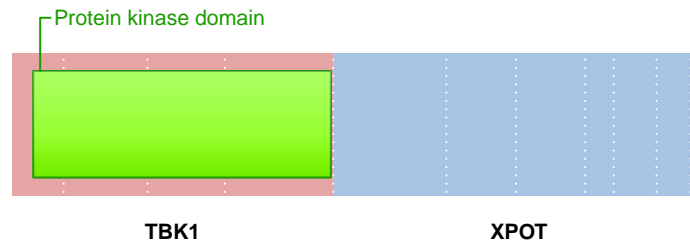

**SUPPORTING READ COUNT**

Split reads = 6  
Discordant mates = 0

— translocation    — deletion  
— duplication    — inversion

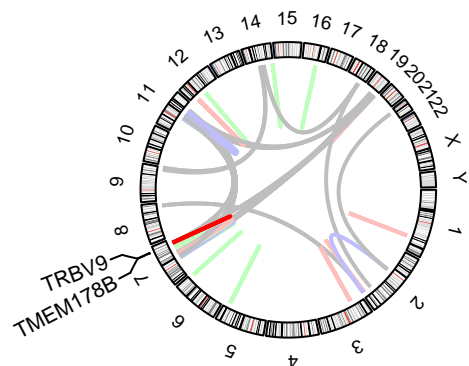
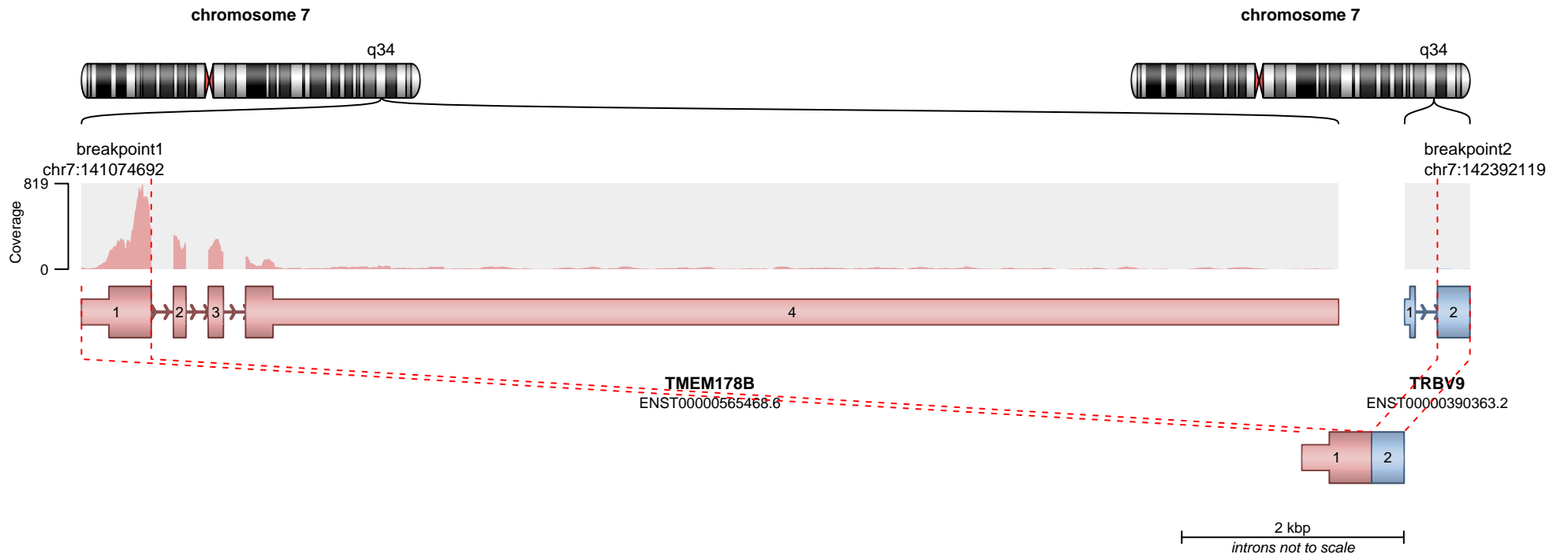

**RETAINED PROTEIN DOMAINS**  
reading frame unclear

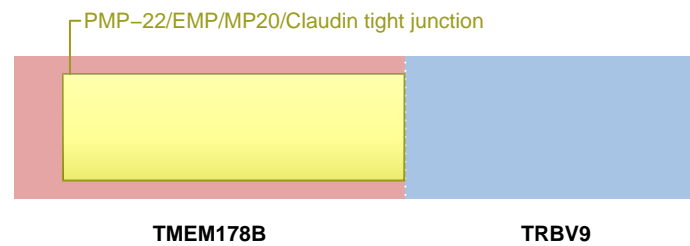

**SUPPORTING READ COUNT**

Split reads = 6  
Discordant mates = 0

- translocation
- duplication
- deletion
- inversion

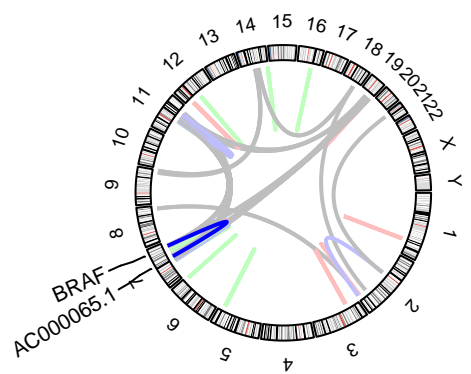
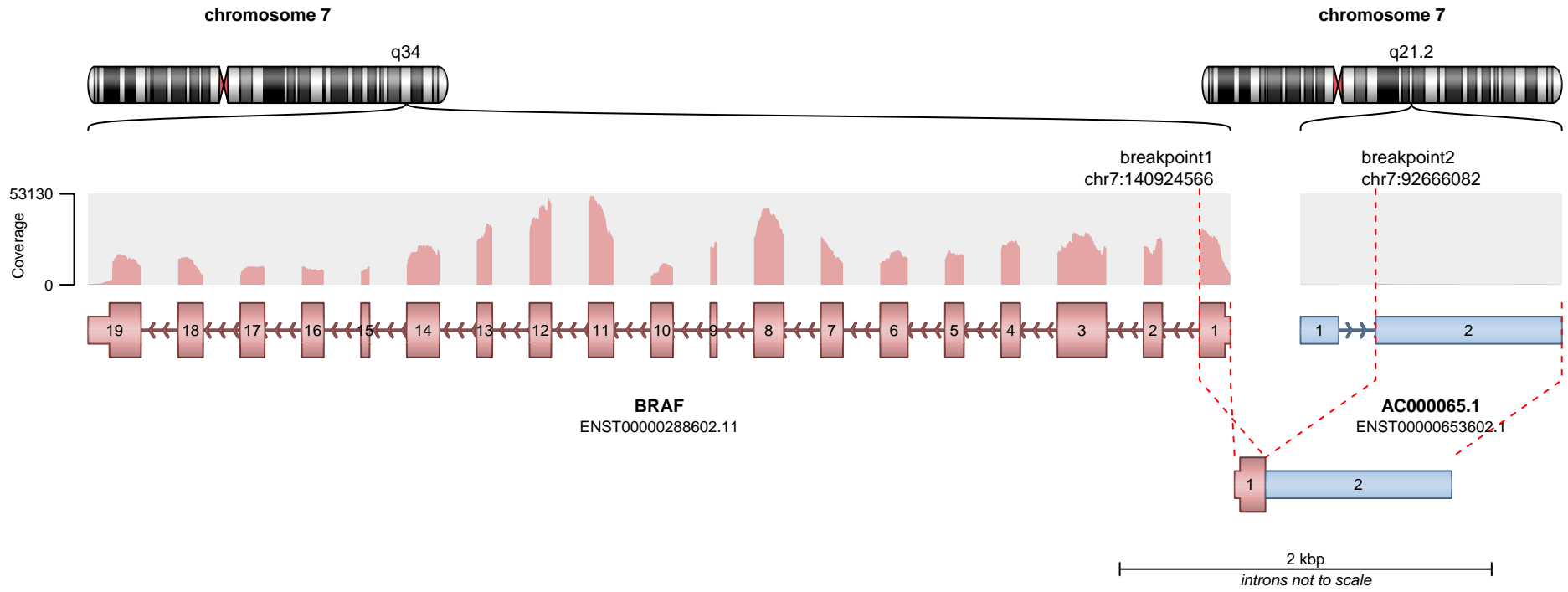

— translocation    — deletion  
— duplication    — inversion

No protein domains retained in fusion.

**SUPPORTING READ COUNT**

Split reads = 5  
 Discordant mates = 0

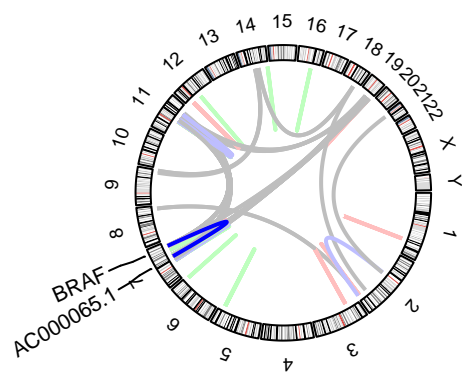
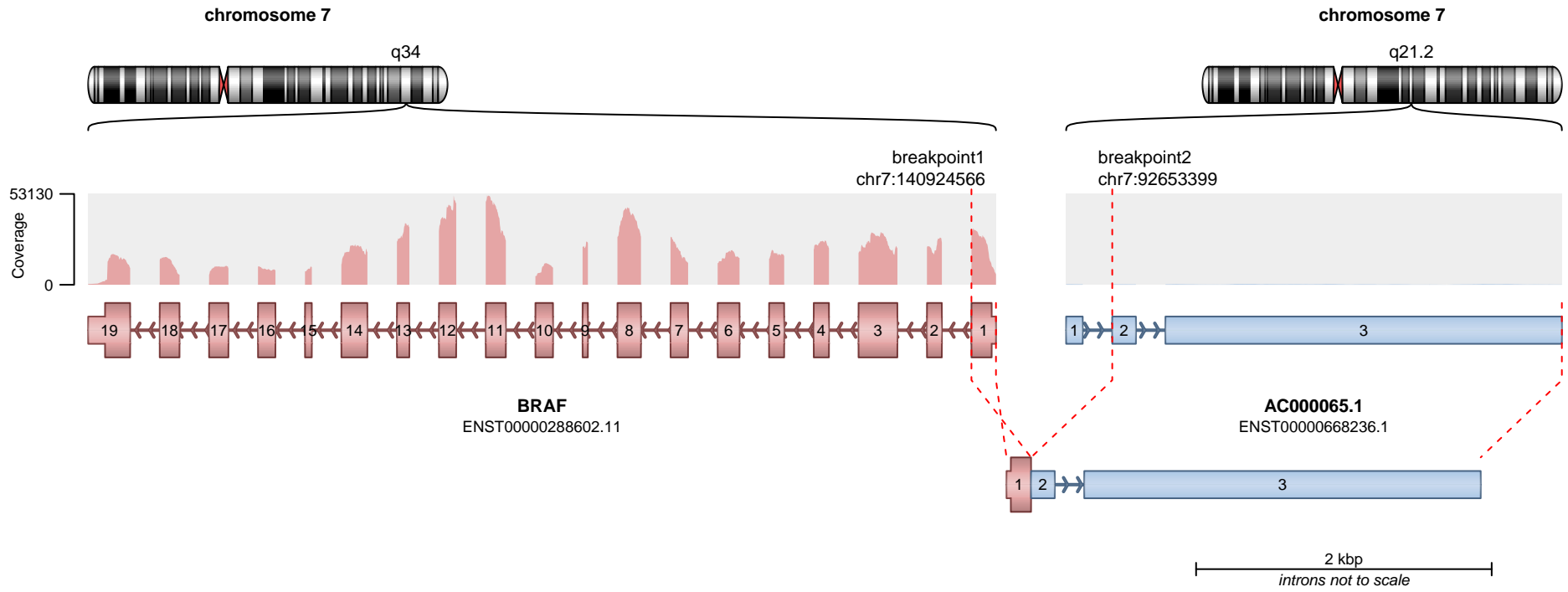

— translocation    — deletion  
— duplication    — inversion

No protein domains retained in fusion.

**SUPPORTING READ COUNT**

Split reads = 1  
Discordant mates = 0

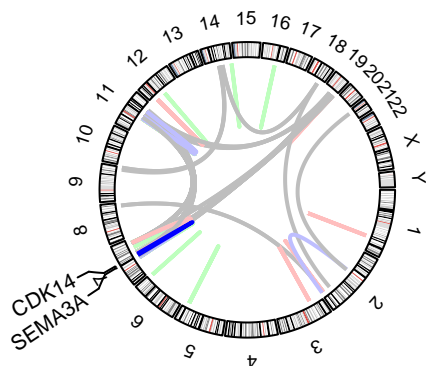
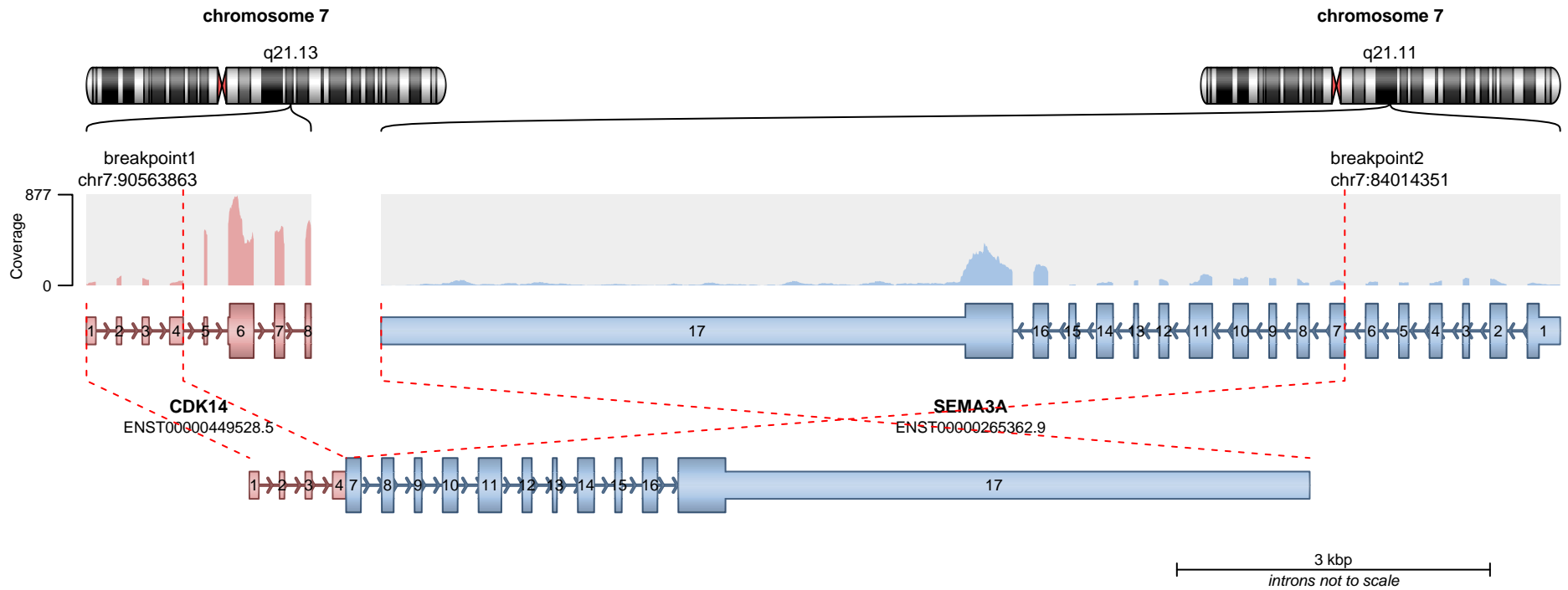

**RETAINED PROTEIN DOMAINS**  
reading frame unclear

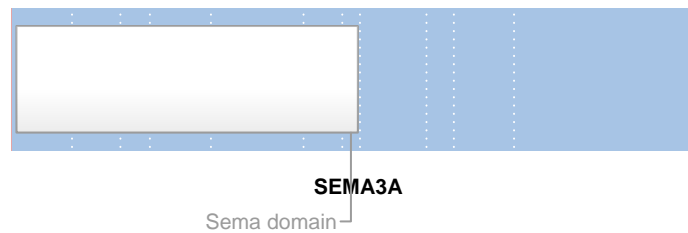

**SUPPORTING READ COUNT**

Split reads = 5  
Discordant mates = 0

- translocation
- duplication
- deletion
- inversion

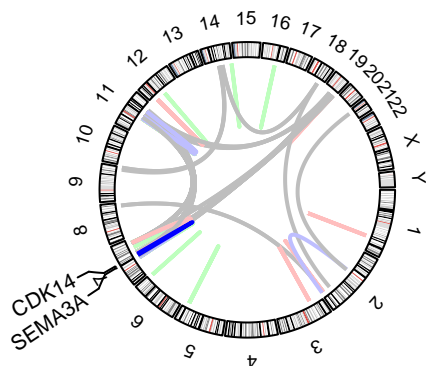
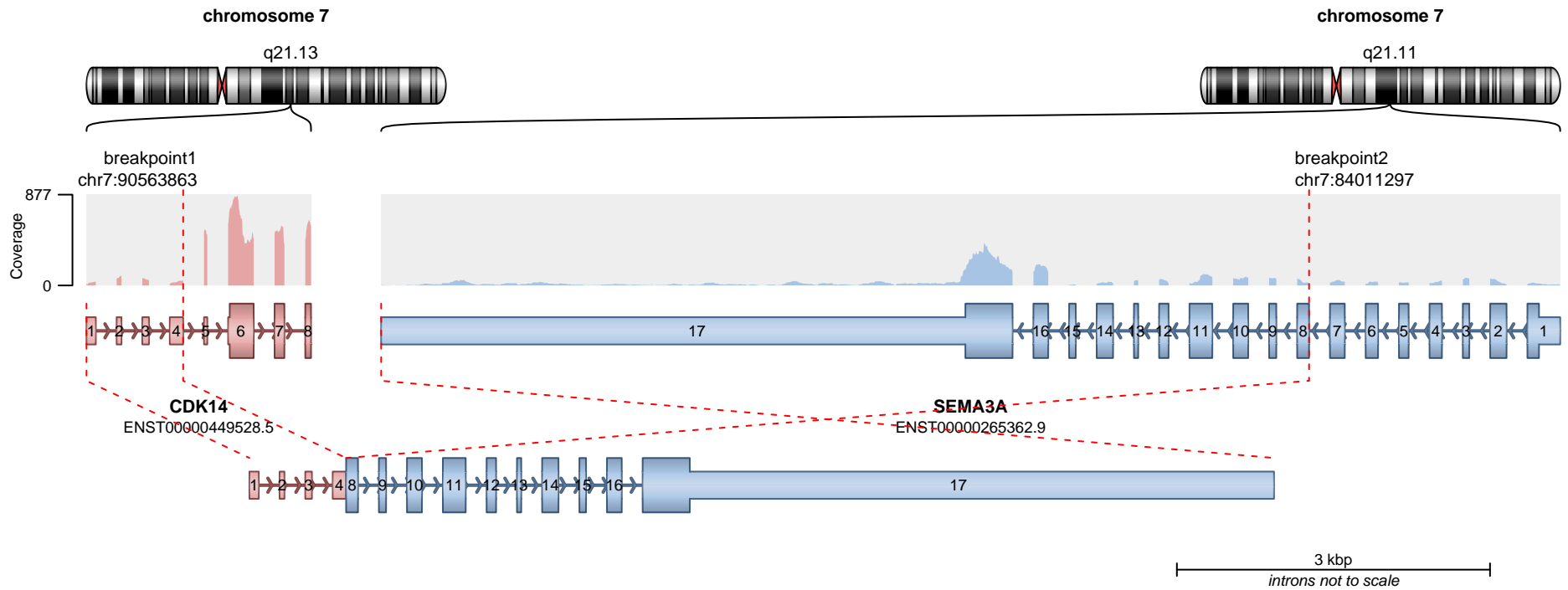

**RETAINED PROTEIN DOMAINS**  
reading frame unclear

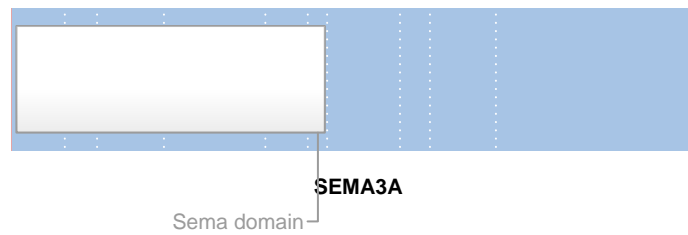

**SUPPORTING READ COUNT**

Split reads = 1  
Discordant mates = 0

- translocation
- duplication
- deletion
- inversion

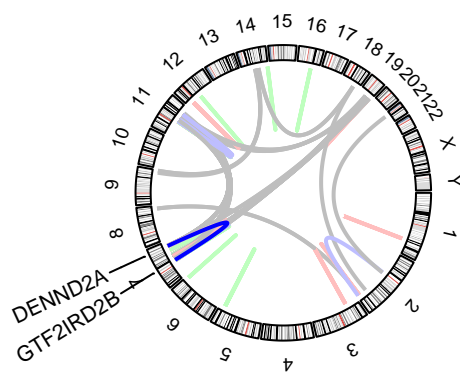
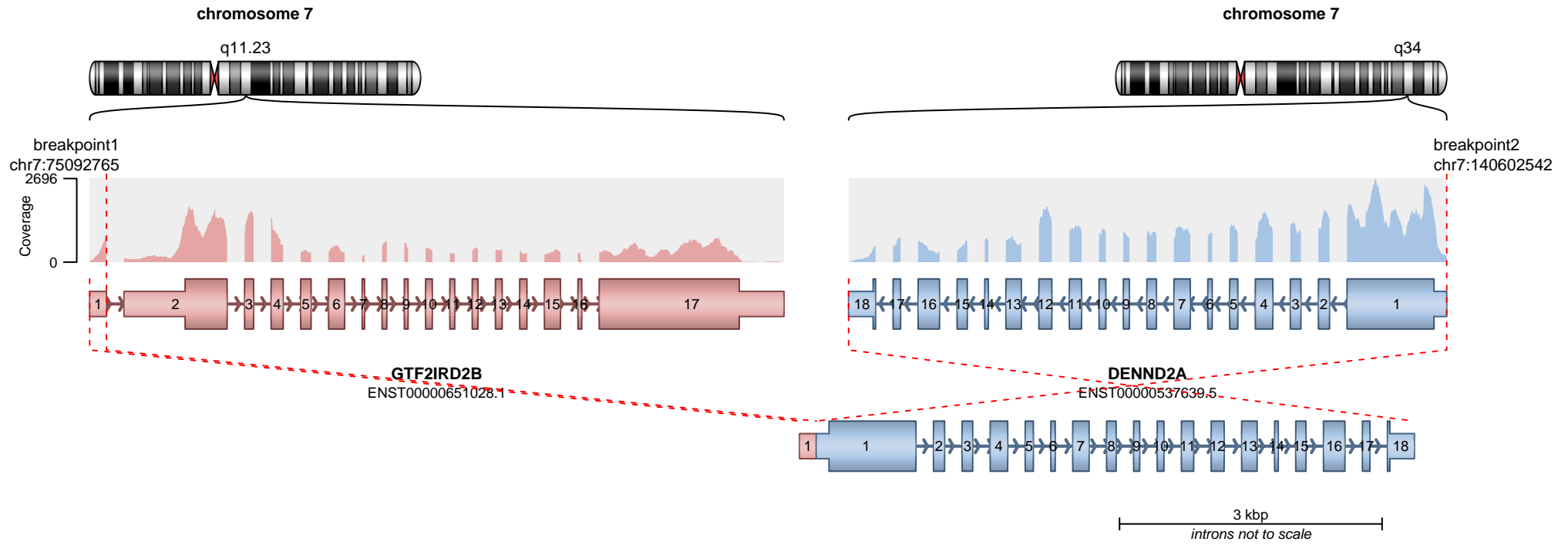

— translocation — deletion  
— duplication — inversion

**RETAINED PROTEIN DOMAINS**  
reading frame unclear

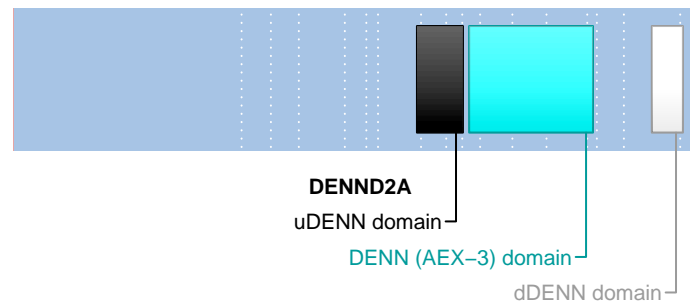

**SUPPORTING READ COUNT**

Split reads = 5  
Discordant mates = 0

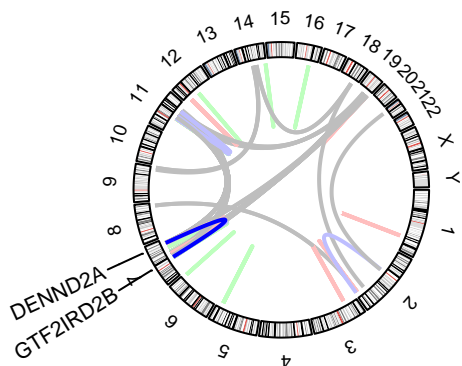
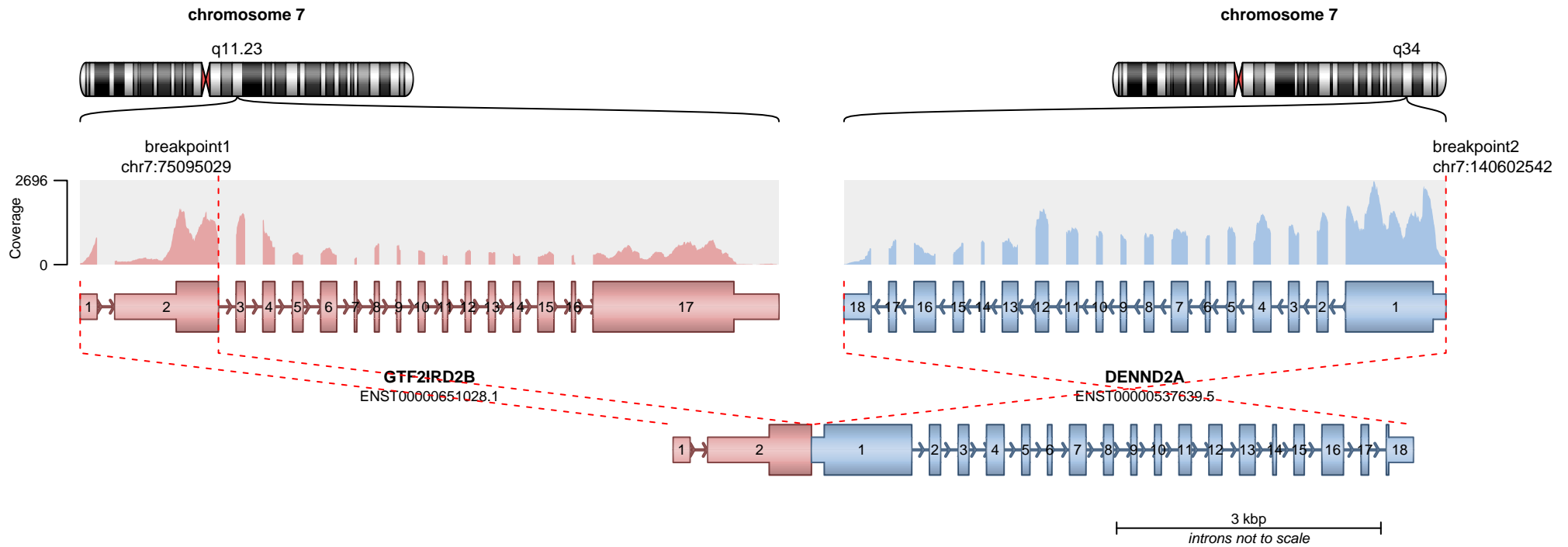

**RETAINED PROTEIN DOMAINS**  
reading frame unclear

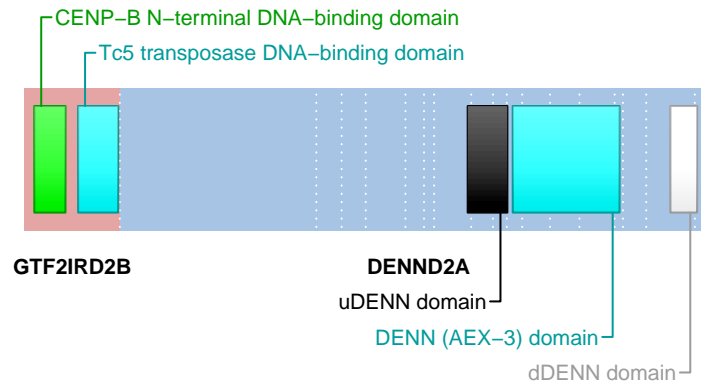

**SUPPORTING READ COUNT**

Split reads = 1  
Discordant mates = 0

— translocation    — deletion  
— duplication    — inversion

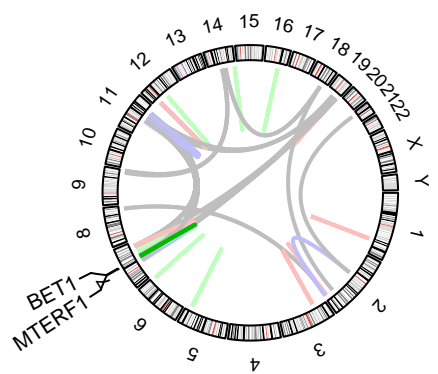
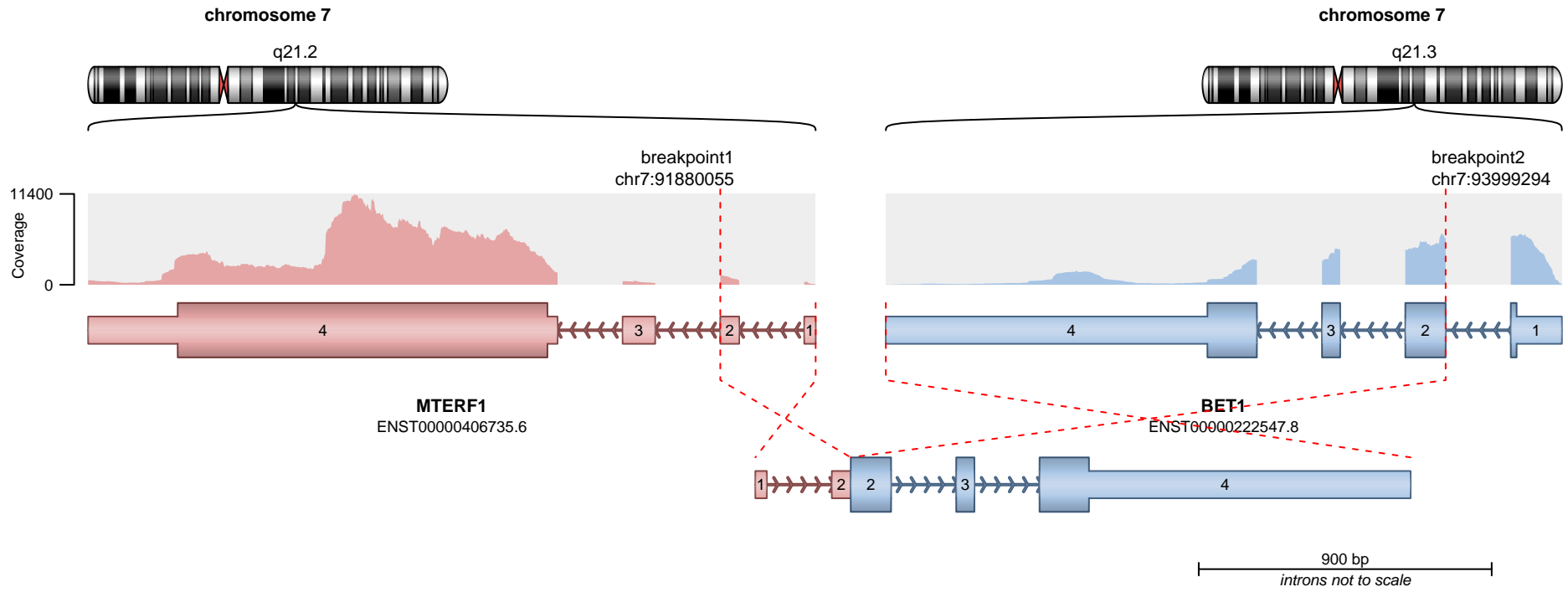

— translocation    — deletion  
— duplication    — inversion

No protein domains retained in fusion.

**SUPPORTING READ COUNT**

Split reads = 5  
Discordant mates = 0

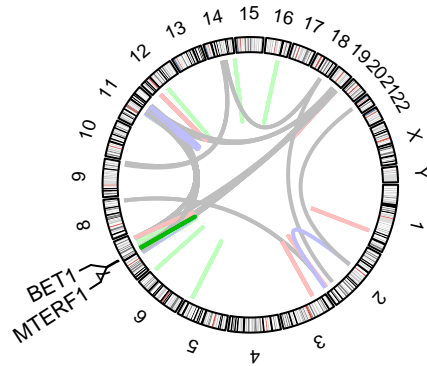
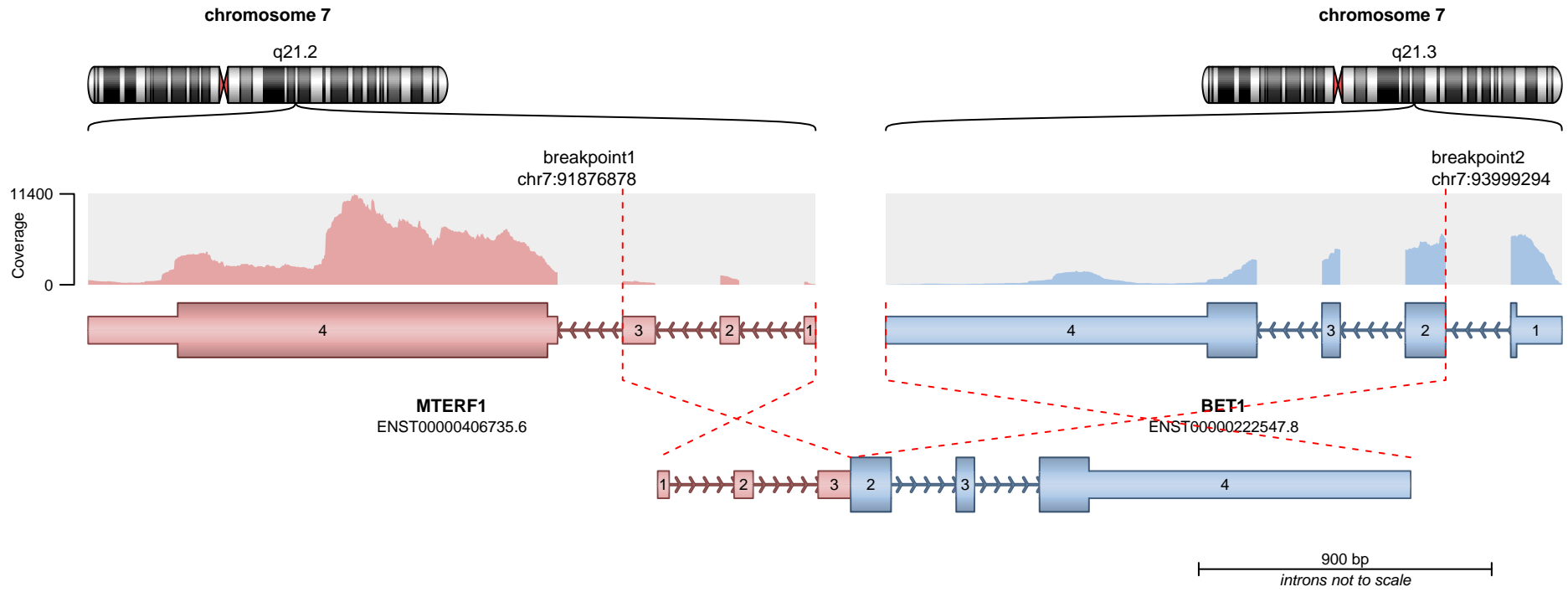

— translocation    — deletion  
— duplication    — inversion

No protein domains retained in fusion.

**SUPPORTING READ COUNT**

Split reads = 1  
Discordant mates = 0

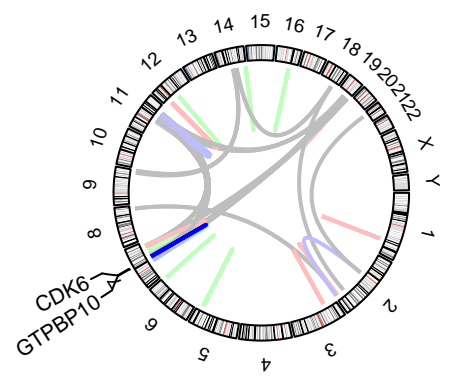
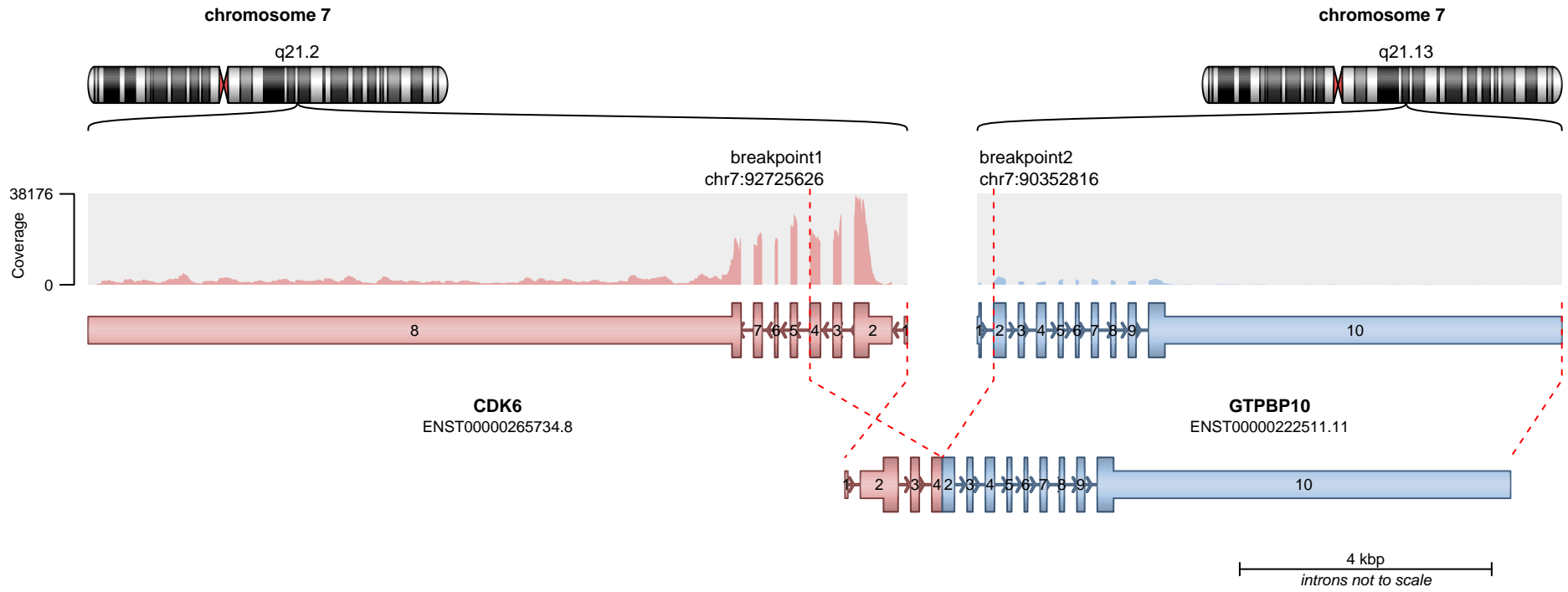

**RETAINED PROTEIN DOMAINS**  
reading frame unclear

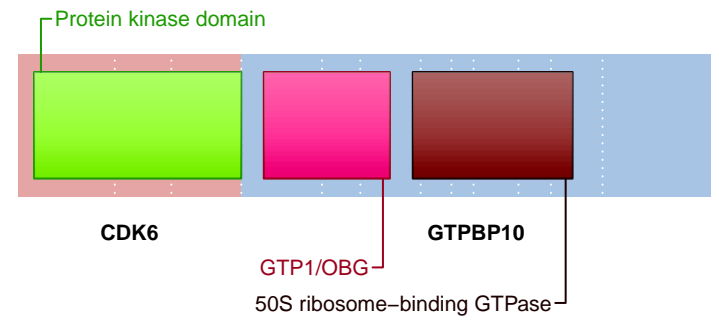

**SUPPORTING READ COUNT**

Split reads = 4  
Discordant mates = 0

- translocation
- duplication
- deletion
- inversion

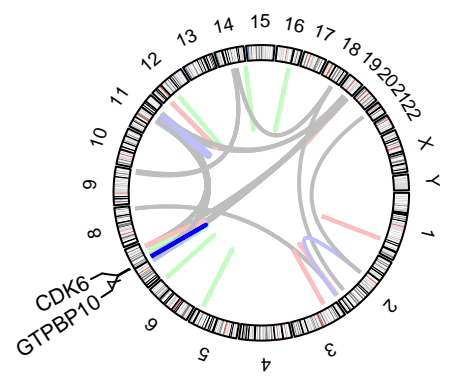
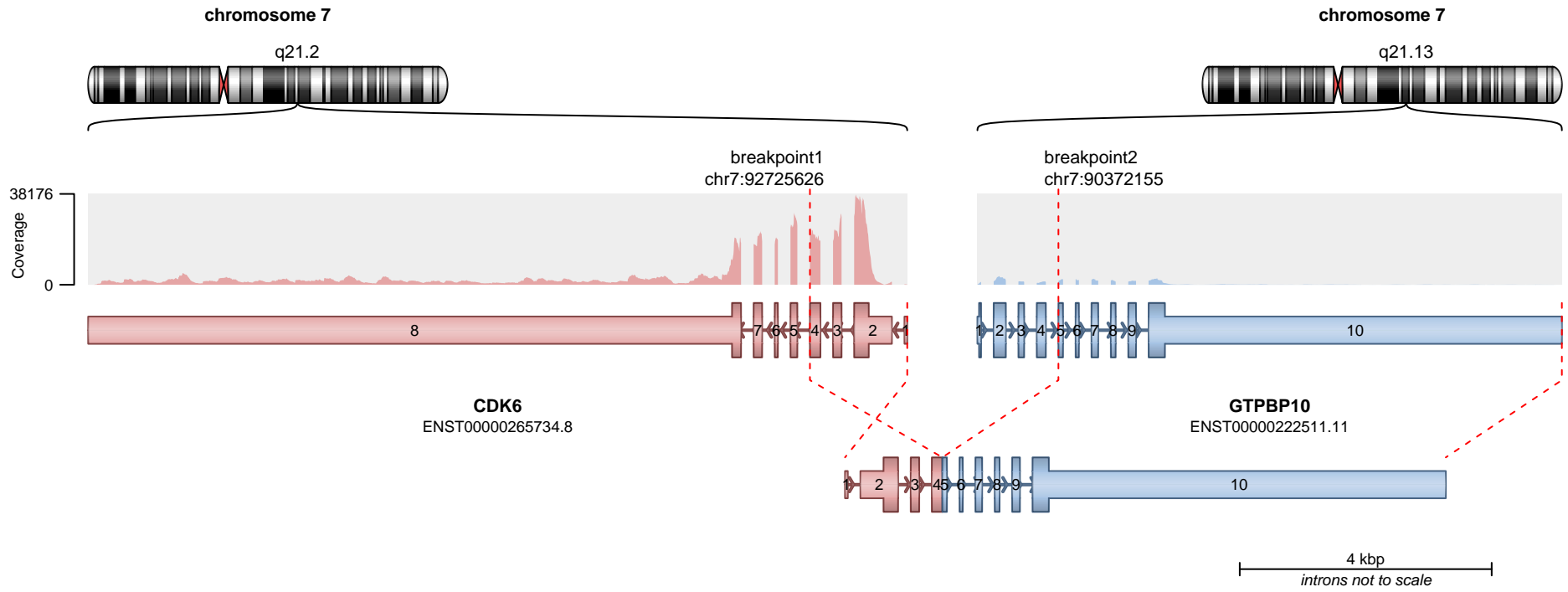

**RETAINED PROTEIN DOMAINS**  
reading frame unclear

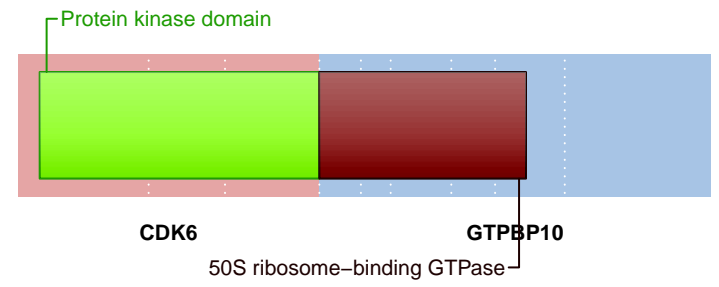

**SUPPORTING READ COUNT**

Split reads = 2  
Discordant mates = 0

- translocation
- duplication
- deletion
- inversion

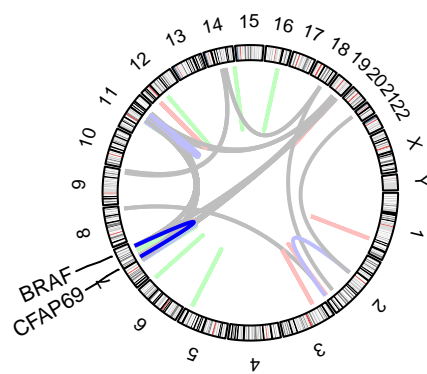
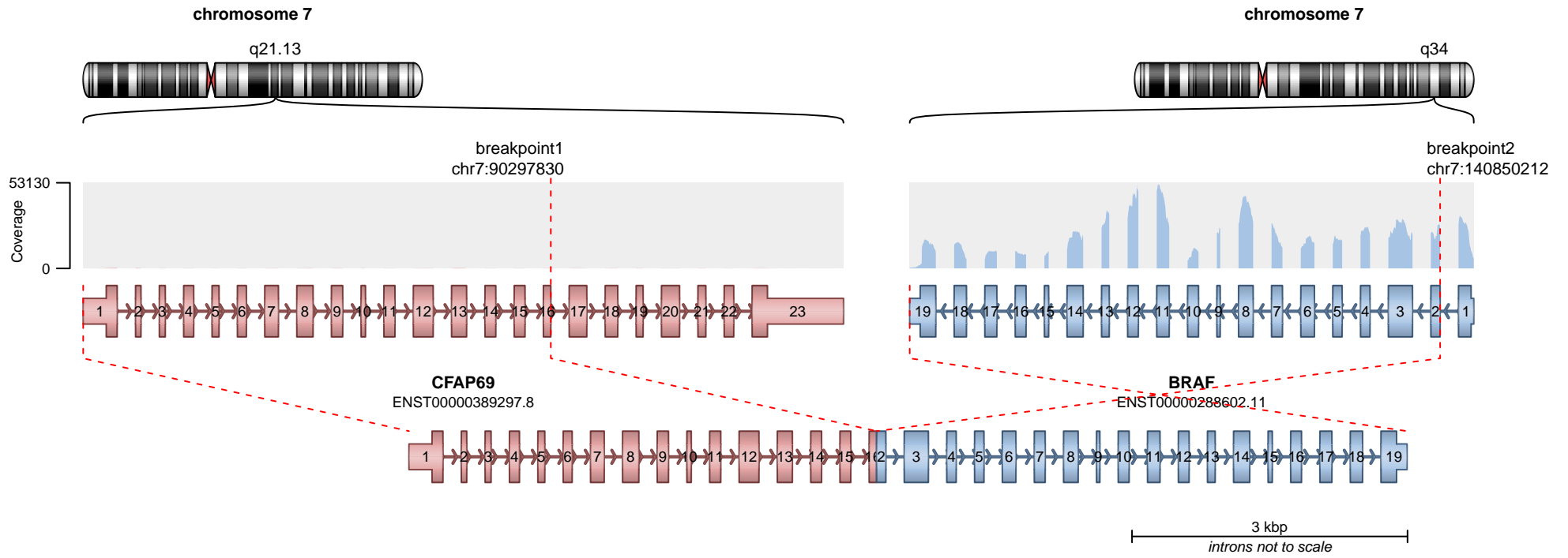

— translocation — deletion  
— duplication — inversion

**RETAINED PROTEIN DOMAINS**  
reading frame unclear

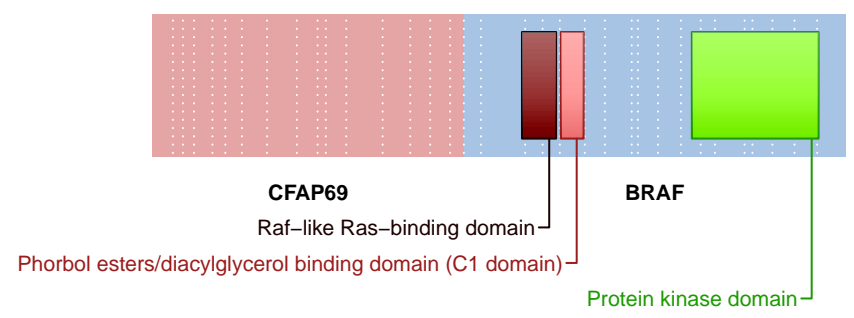

**SUPPORTING READ COUNT**

Split reads = 4  
Discordant mates = 0

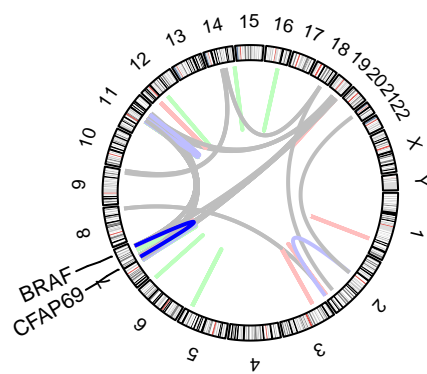
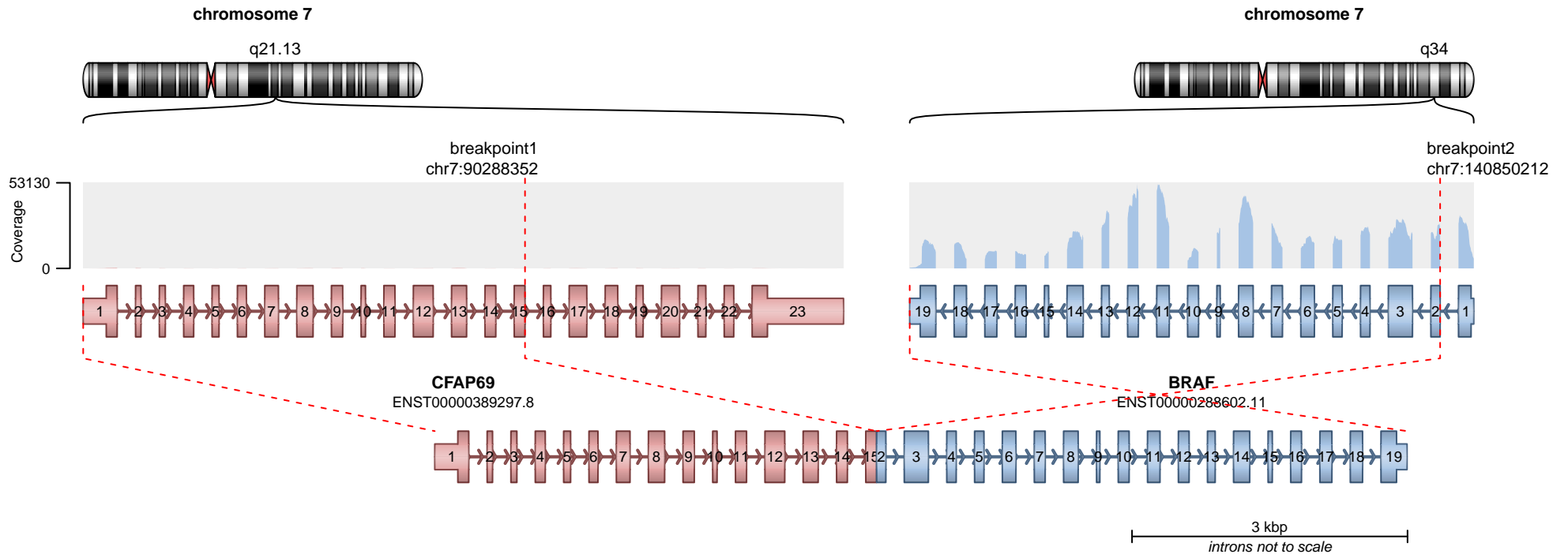

**RETAINED PROTEIN DOMAINS**  
reading frame unclear

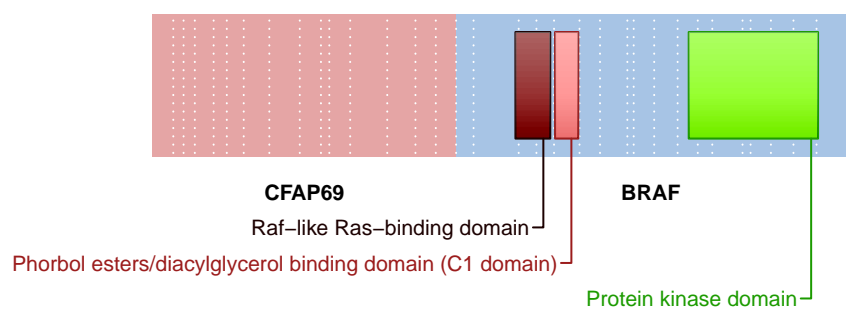

**SUPPORTING READ COUNT**

Split reads = 3  
Discordant mates = 0

- translocation
- duplication
- deletion
- inversion

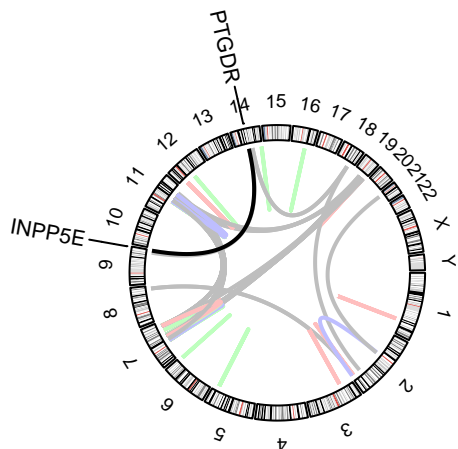
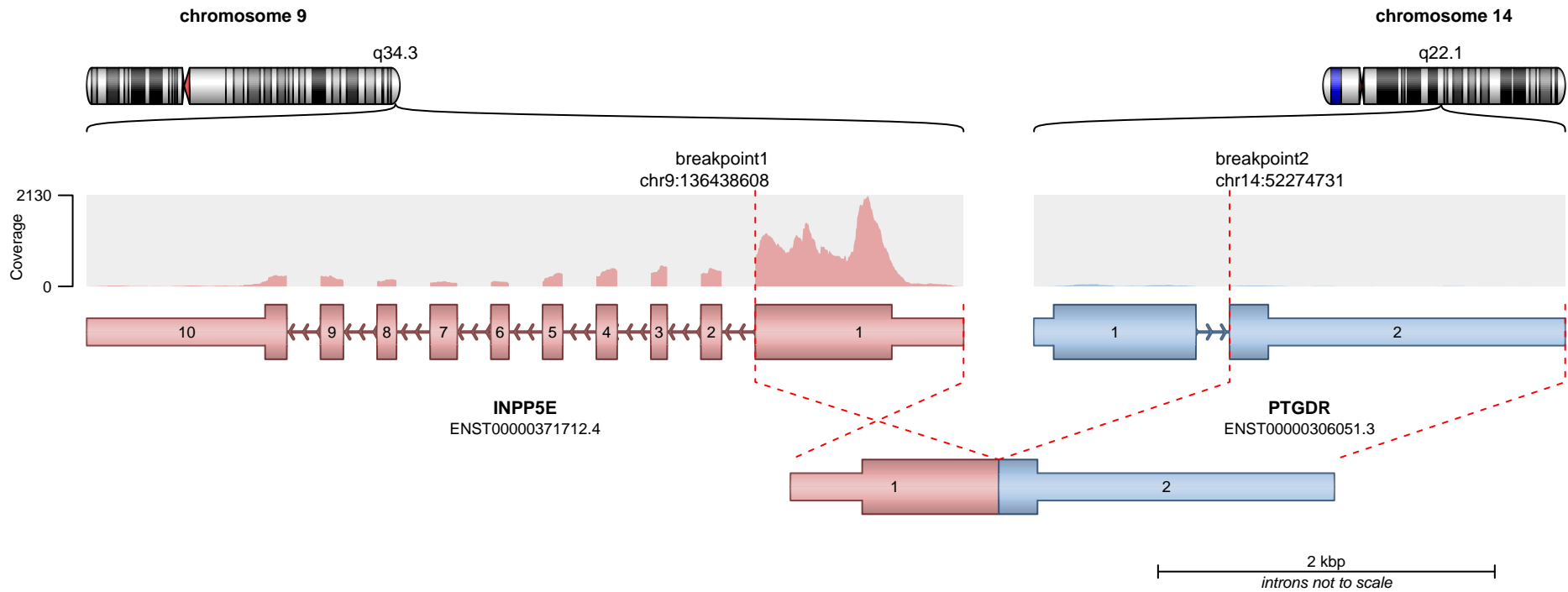

**RETAINED PROTEIN DOMAINS**  
reading frame unclear

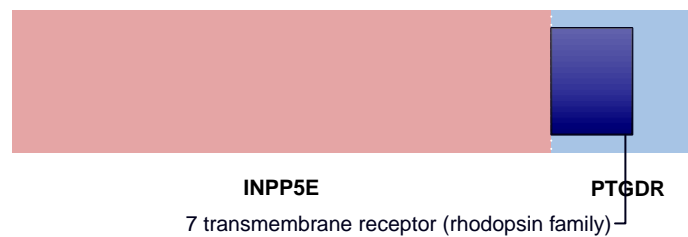

**SUPPORTING READ COUNT**

Split reads = 4  
Discordant mates = 0

- translocation
- duplication
- deletion
- inversion

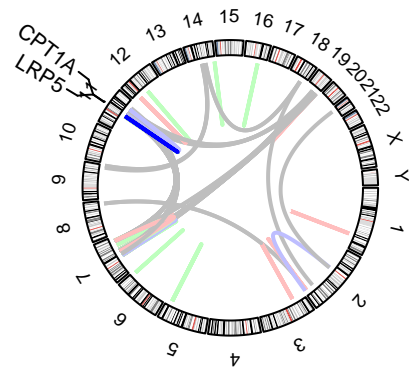
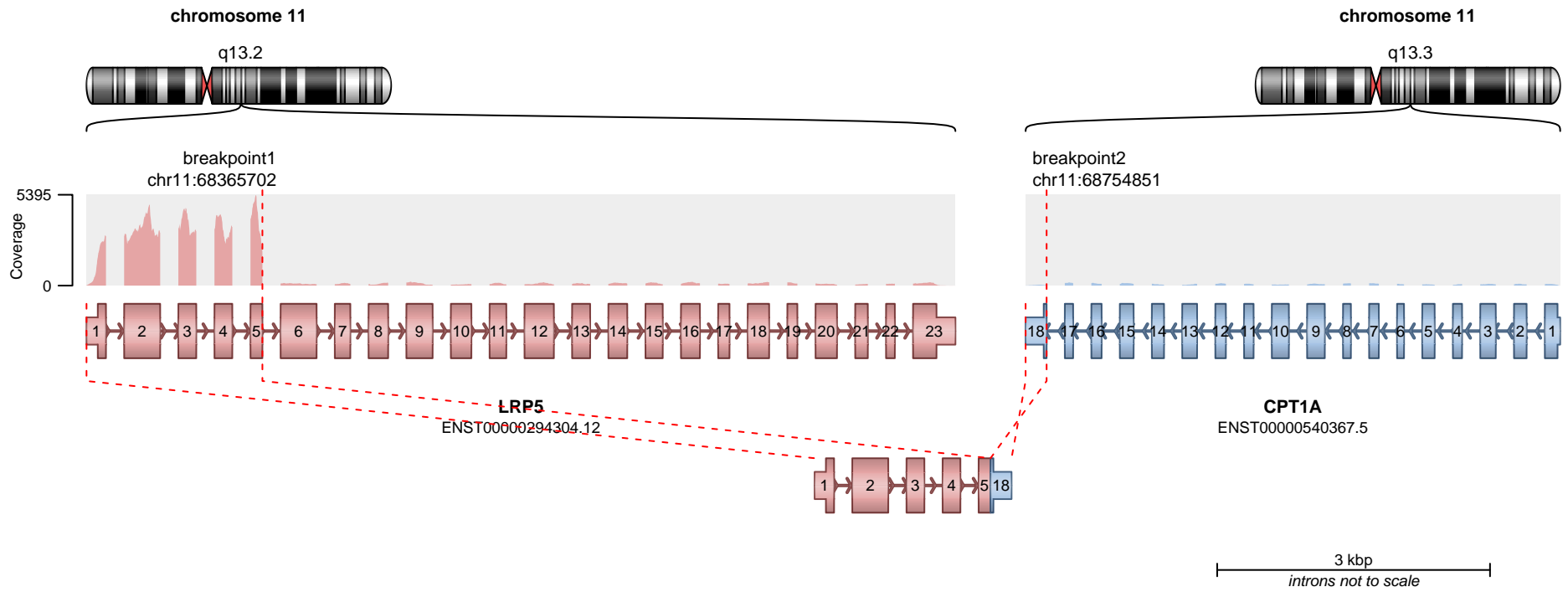

**RETAINED PROTEIN DOMAINS**  
reading frame unclear

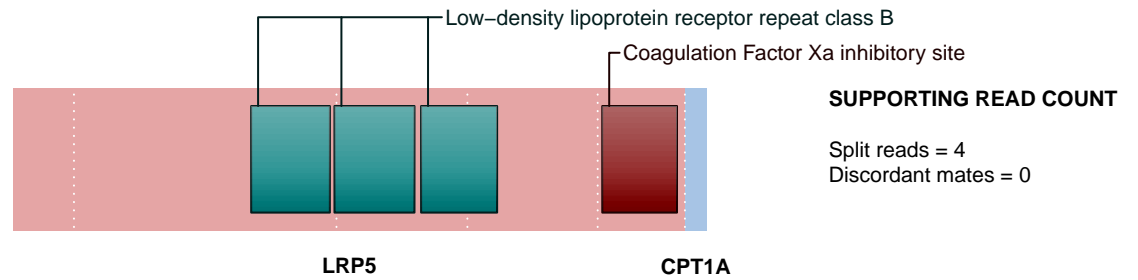

- translocation
- duplication
- deletion
- inversion

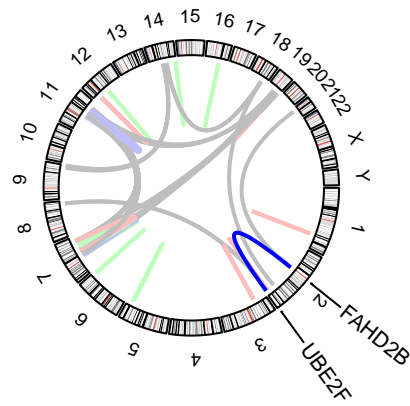
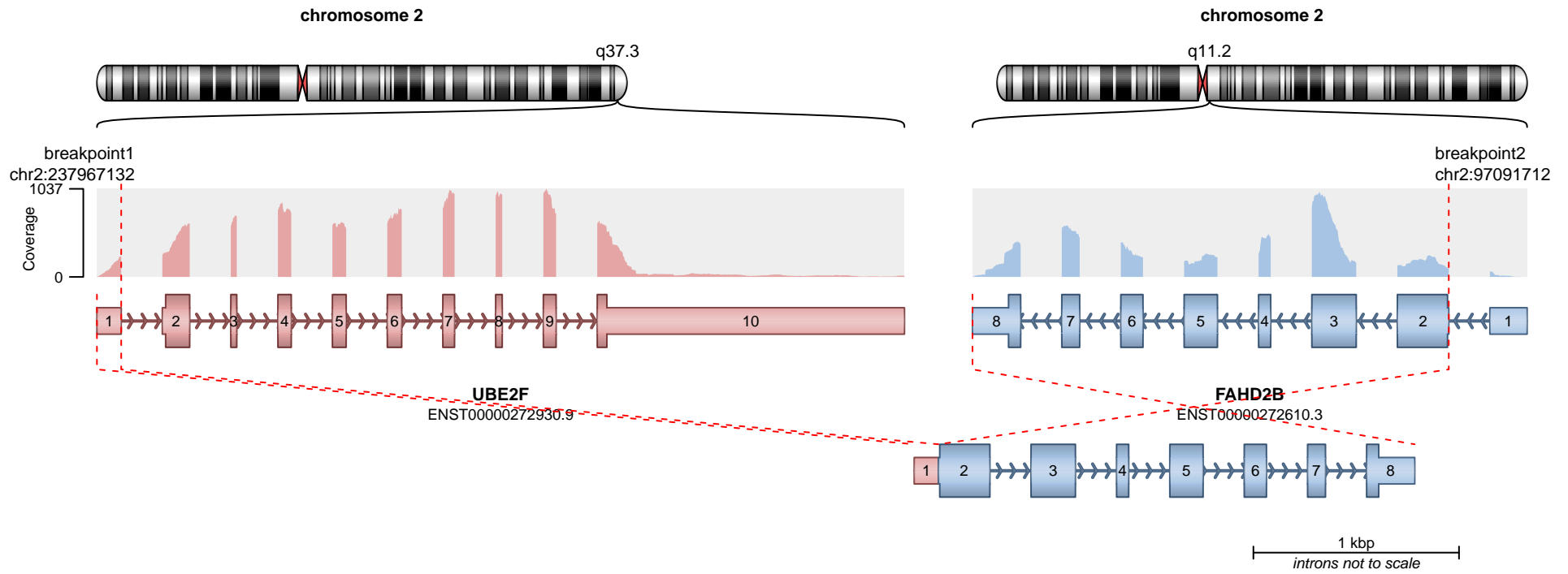

**RETAINED PROTEIN DOMAINS**  
reading frame unclear

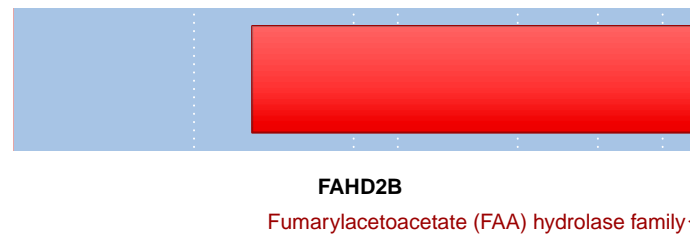

**SUPPORTING READ COUNT**

Split reads = 4  
Discordant mates = 0

— translocation — deletion  
— duplication — inversion

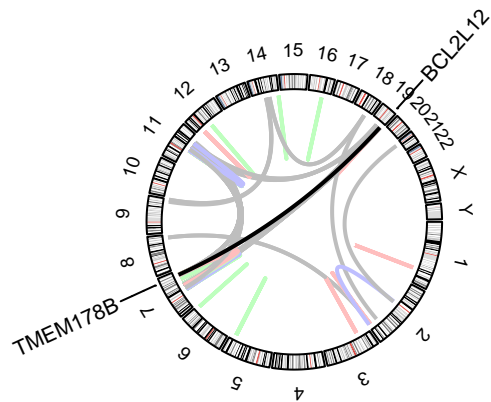
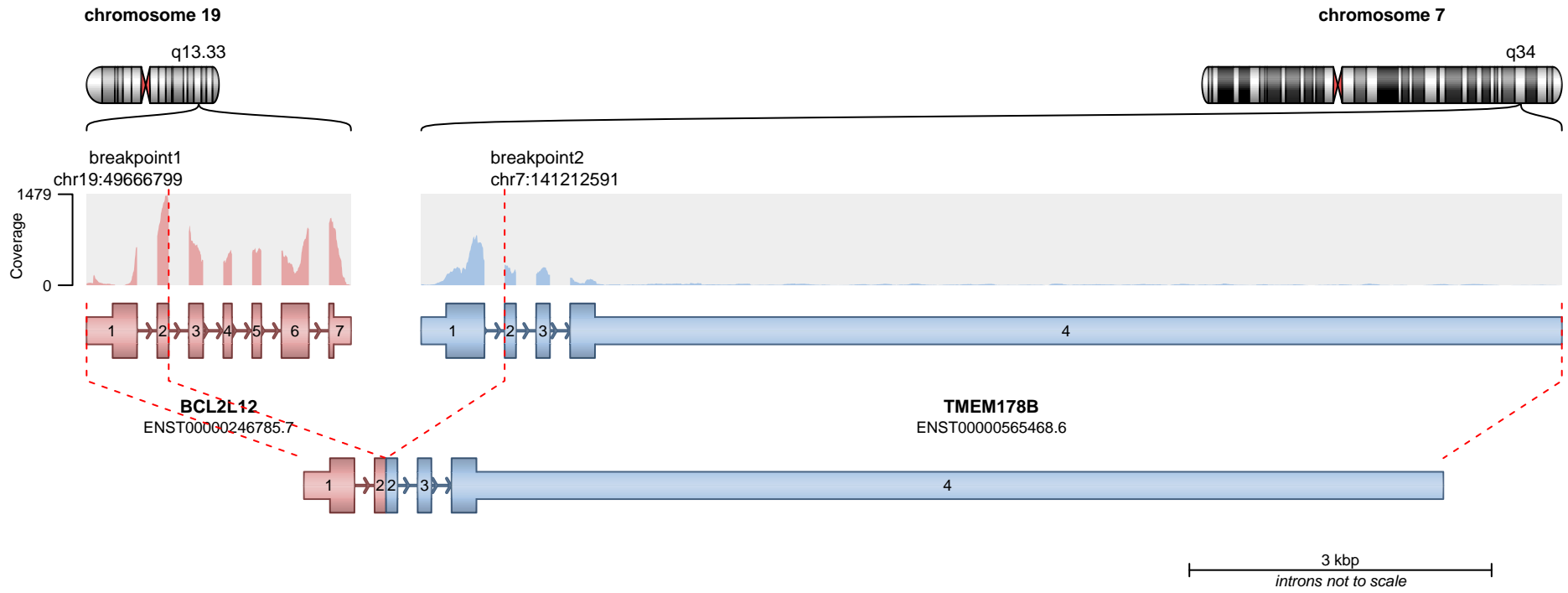

**RETAINED PROTEIN DOMAINS**  
reading frame unclear

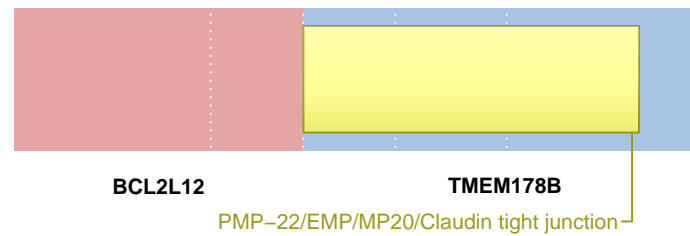

**SUPPORTING READ COUNT**

Split reads = 3  
Discordant mates = 0

— translocation — deletion  
— duplication — inversion

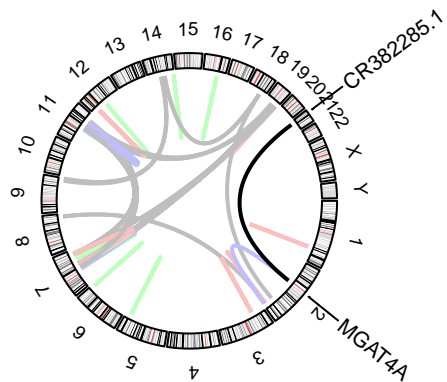
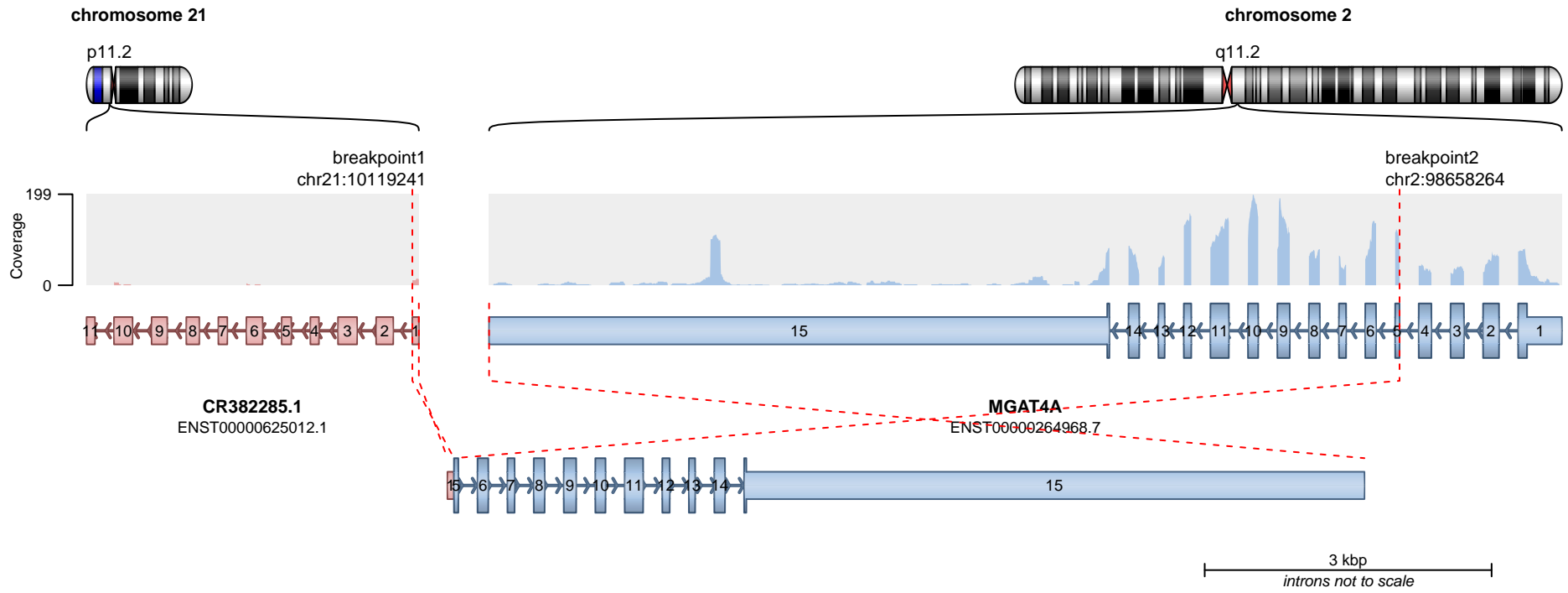

**RETAINED PROTEIN DOMAINS**  
reading frame unclear



N-Acetylglucosaminyltransferase-IV (GnT-IV) conserved region

**SUPPORTING READ COUNT**

Split reads = 3  
Discordant mates = 0

— translocation — deletion  
— duplication — inversion

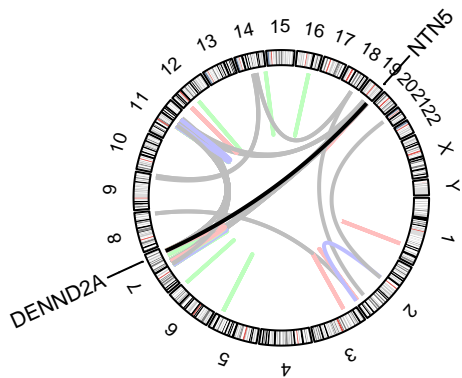
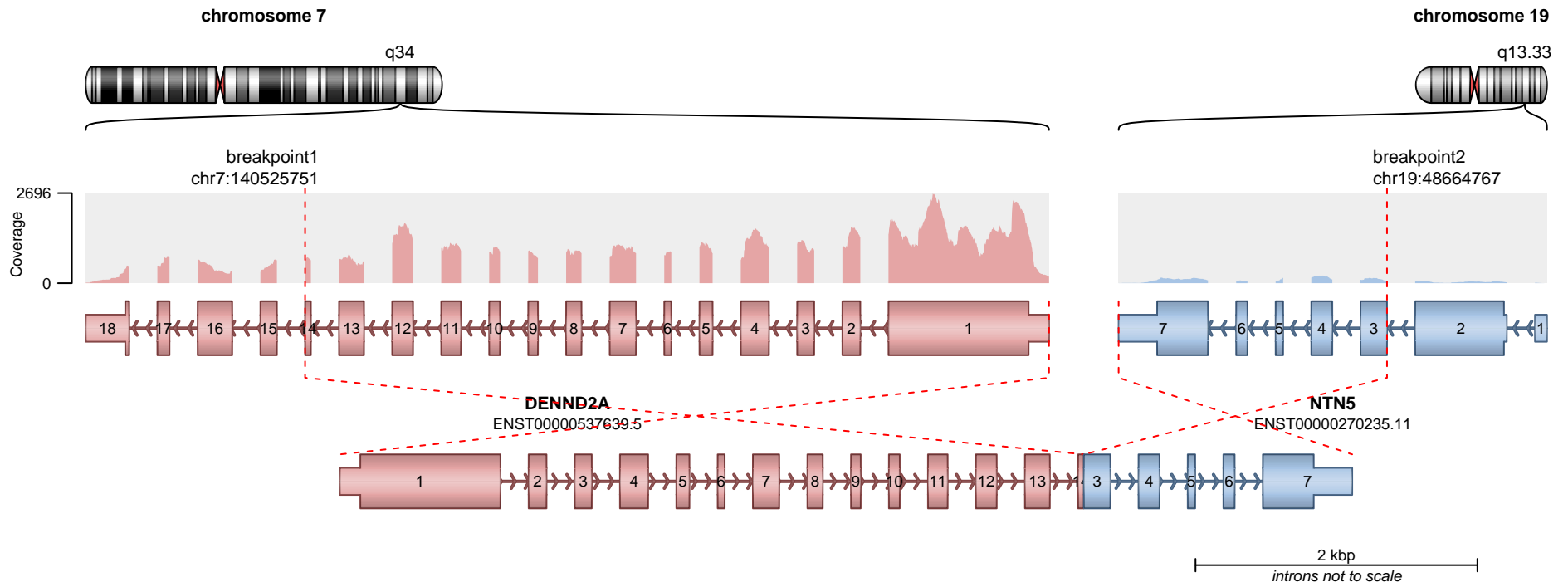

**RETAINED PROTEIN DOMAINS**  
reading frame unclear

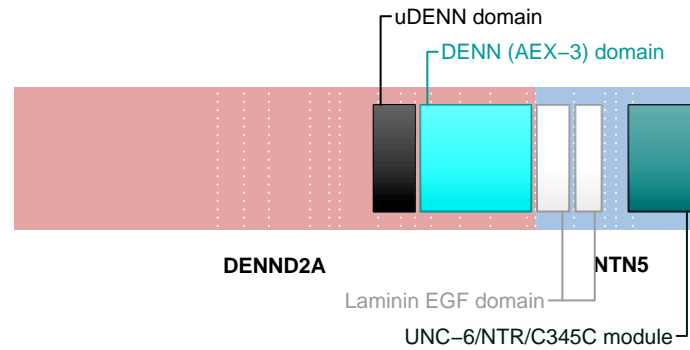

**SUPPORTING READ COUNT**

Split reads = 3  
Discordant mates = 0

- translocation
- duplication
- deletion
- inversion

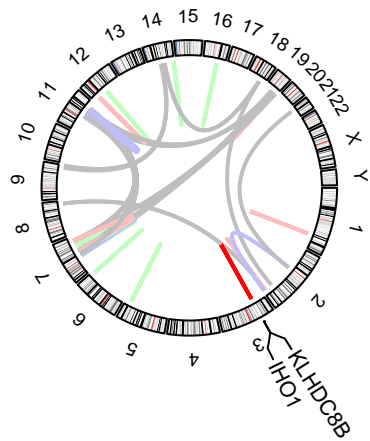
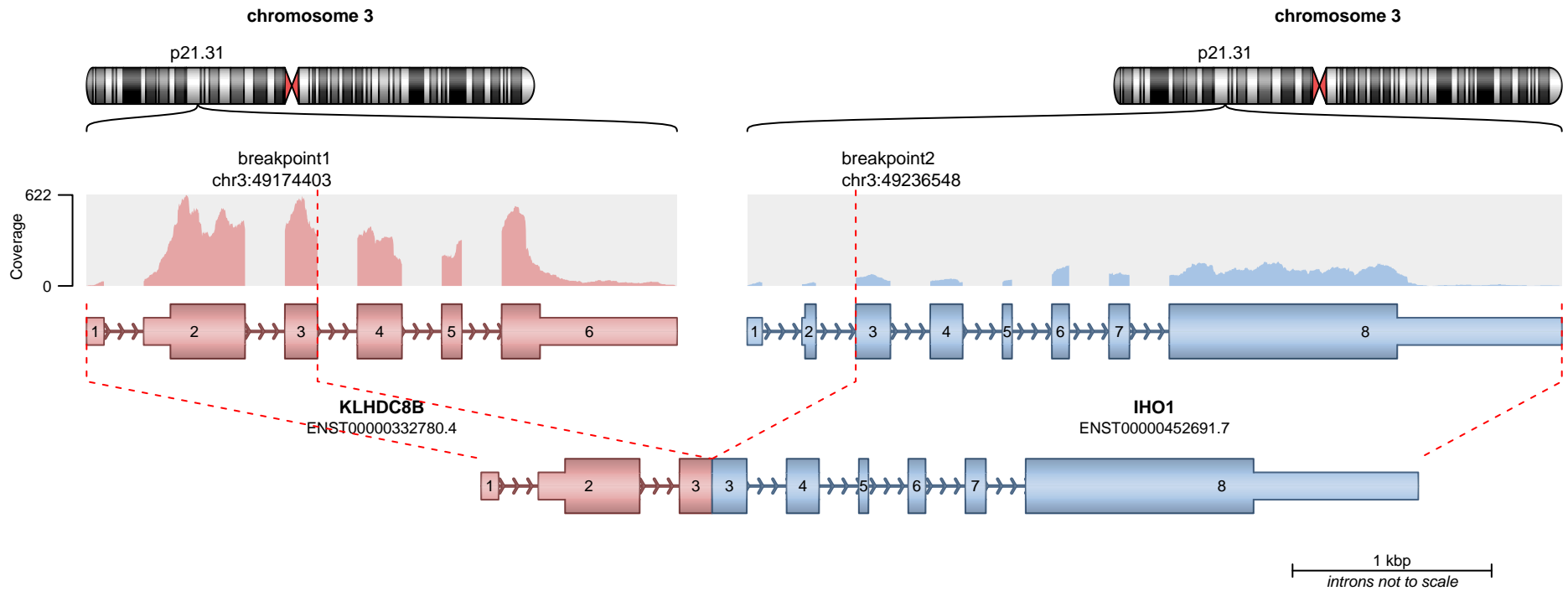

**RETAINED PROTEIN DOMAINS**  
reading frame unclear

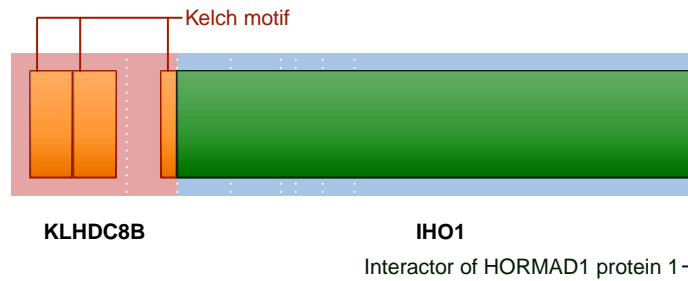

**SUPPORTING READ COUNT**

Split reads = 3  
Discordant mates = 0

— translocation    — deletion  
— duplication    — inversion

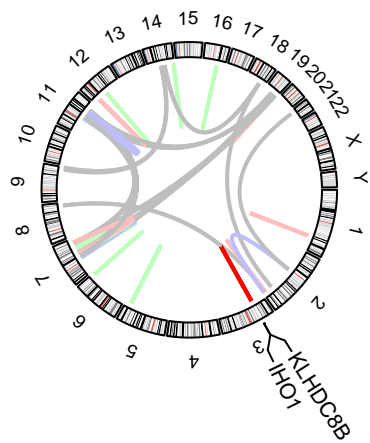
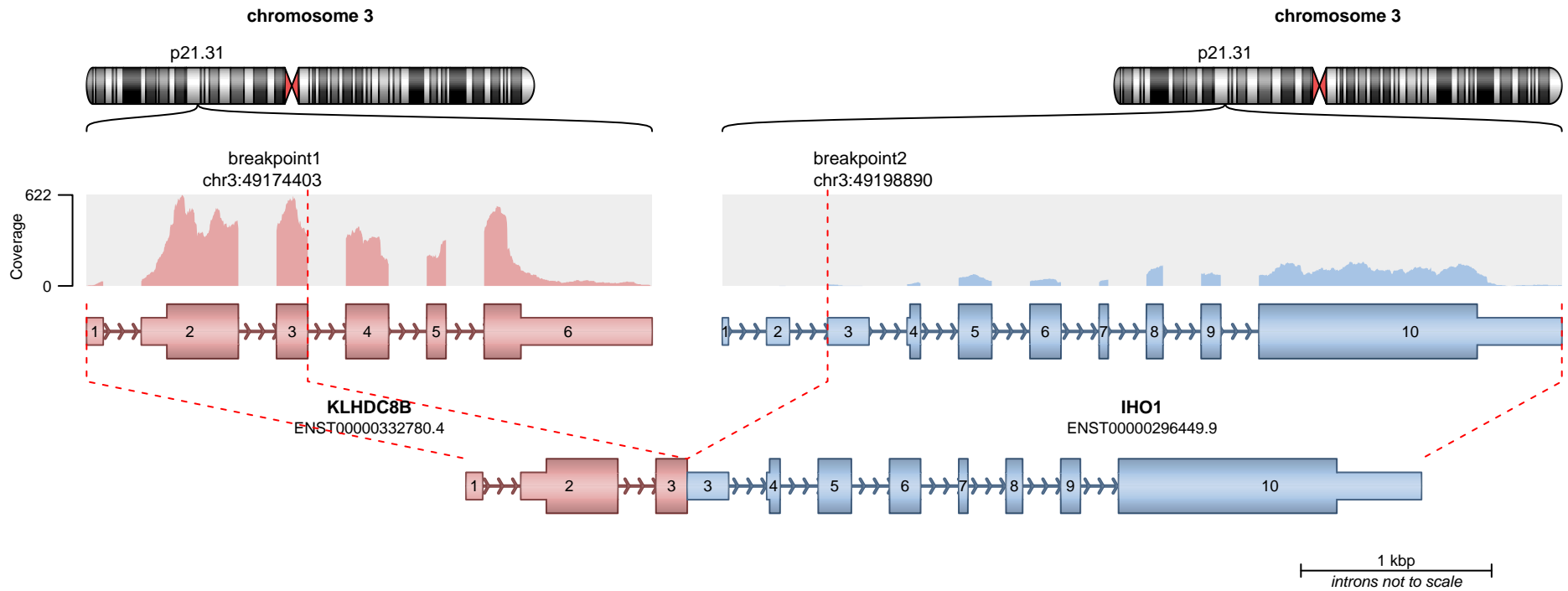

**RETAINED PROTEIN DOMAINS**  
reading frame unclear

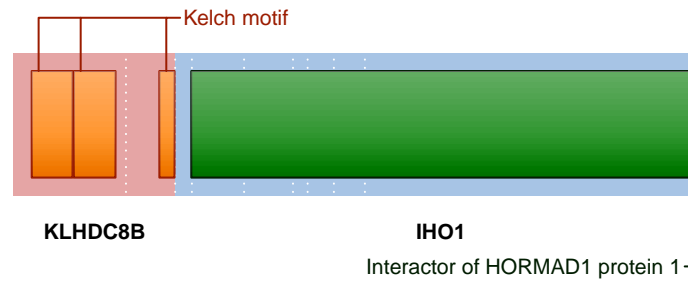

**SUPPORTING READ COUNT**

Split reads = 2  
Discordant mates = 0

— translocation — deletion  
— duplication — inversion

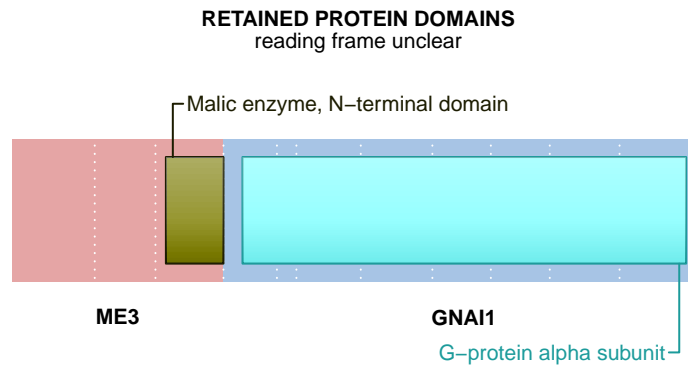
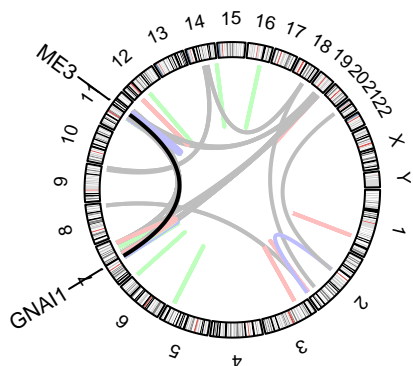
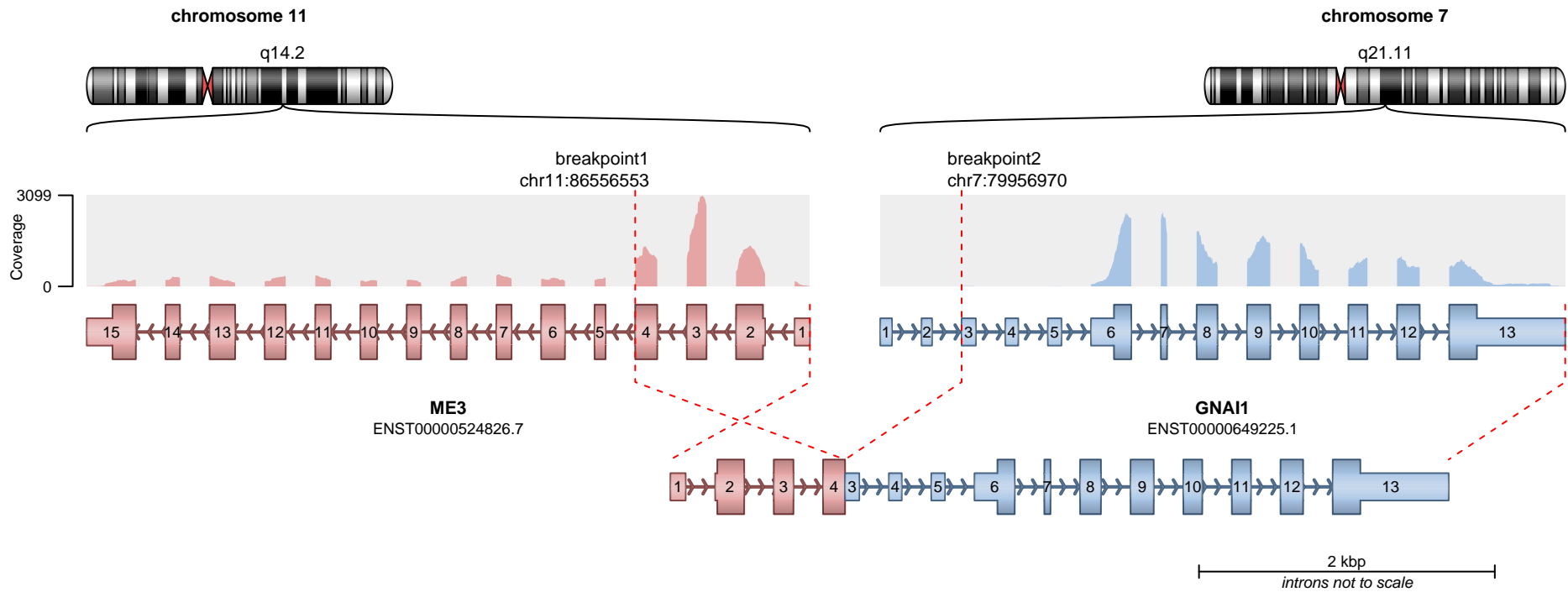

**SUPPORTING READ COUNT**

Split reads = 3  
Discordant mates = 0

— translocation    — deletion  
— duplication    — inversion

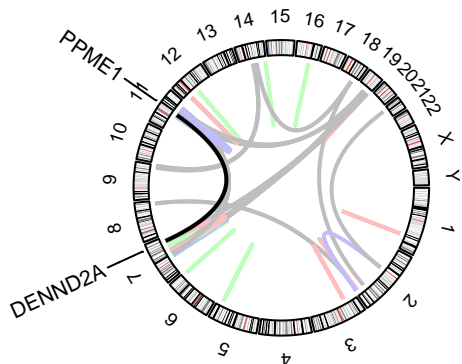
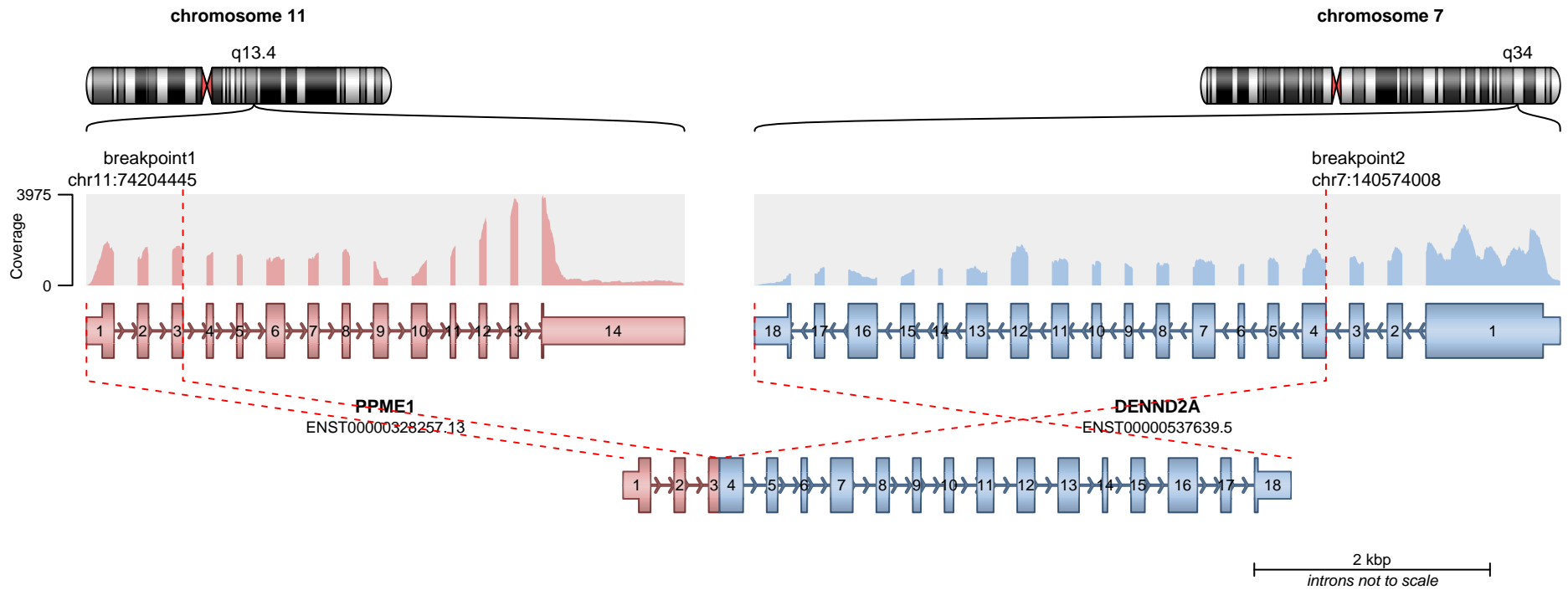

**RETAINED PROTEIN DOMAINS**  
reading frame unclear

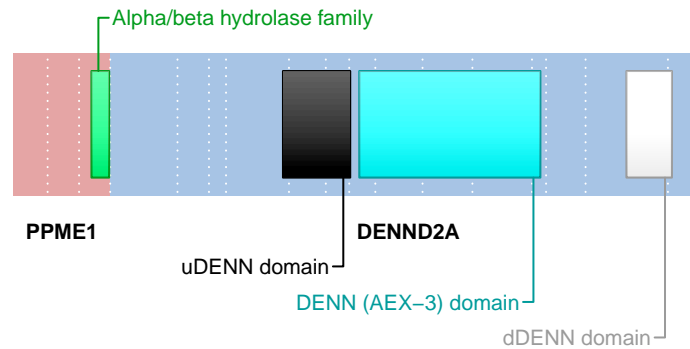

**SUPPORTING READ COUNT**

Split reads = 3  
Discordant mates = 0

- translocation
- duplication
- deletion
- inversion

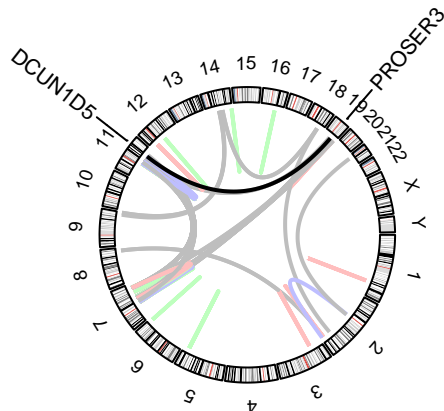
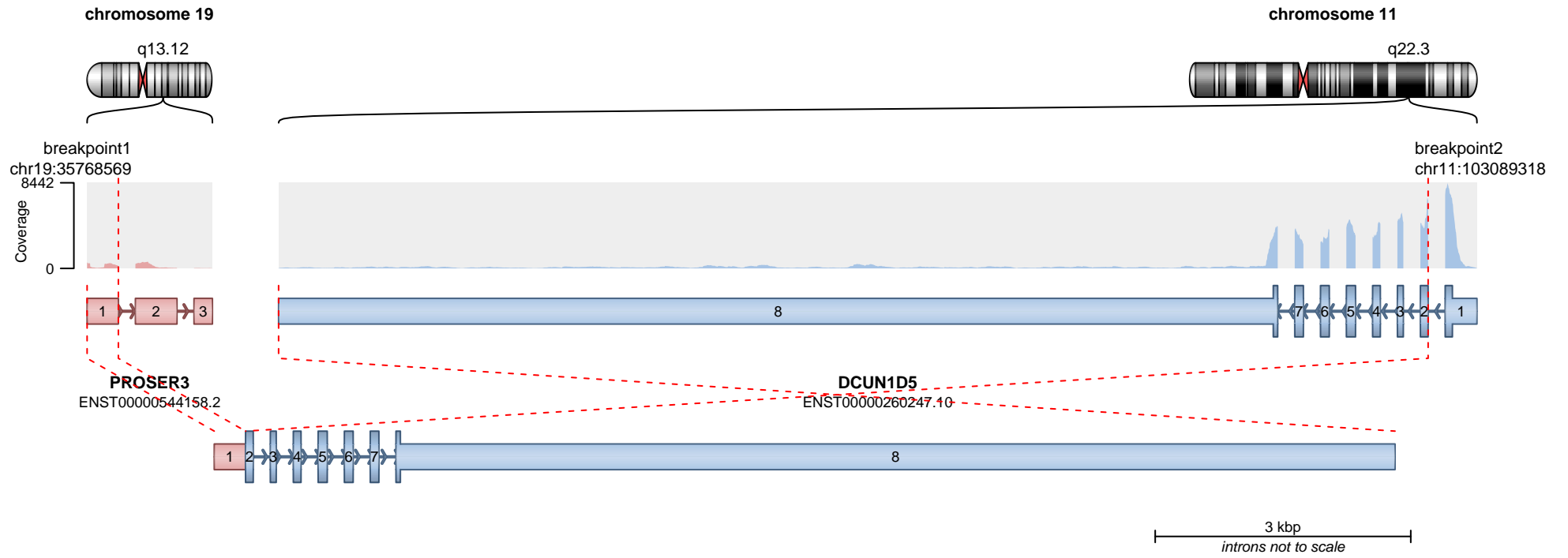

— translocation — deletion  
— duplication — inversion

**RETAINED PROTEIN DOMAINS**  
reading frame unclear

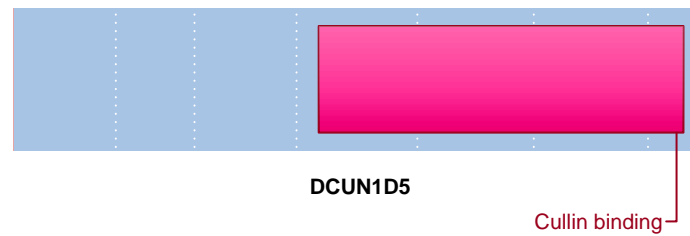

**SUPPORTING READ COUNT**

Split reads = 3  
Discordant mates = 0

chromosome 19

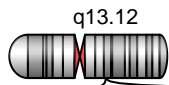

q13.12

chromosome 11



q22.3

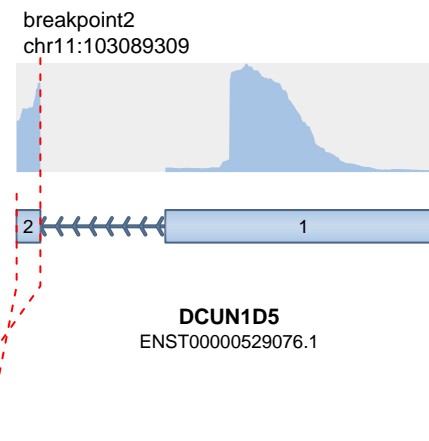
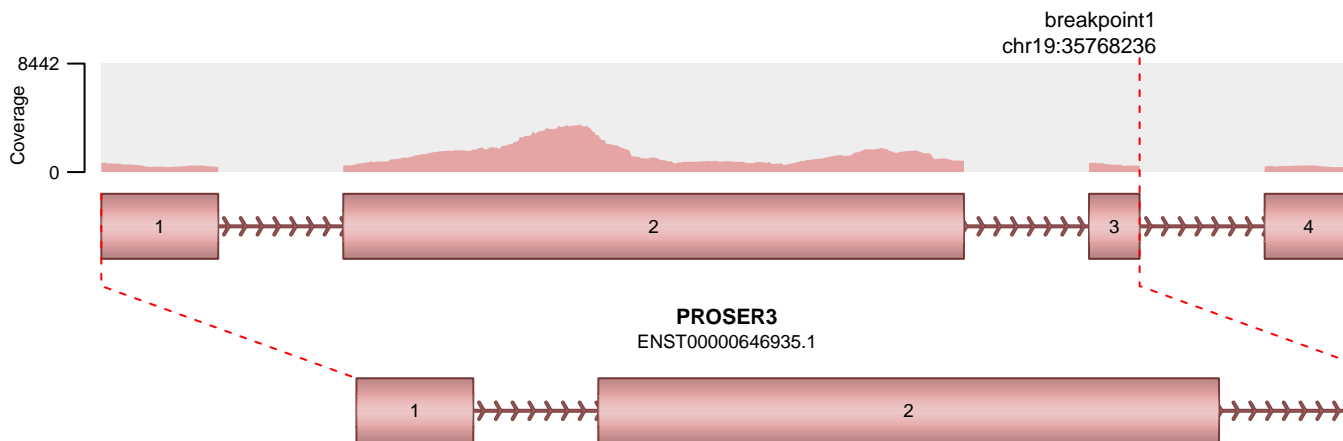

500 bp  
*introns not to scale*

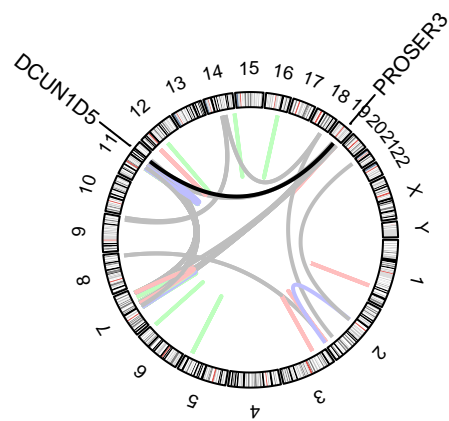

— translocation    — deletion  
— duplication    — inversion

No protein domains retained in fusion.

**SUPPORTING READ COUNT**

Split reads = 1  
Discordant mates = 0

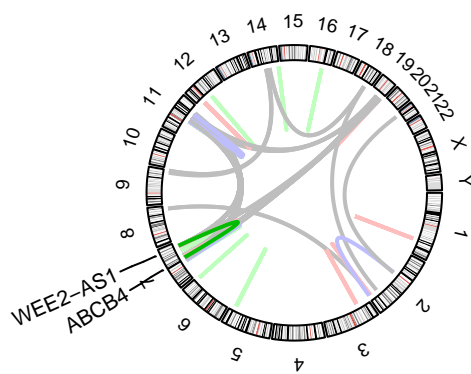
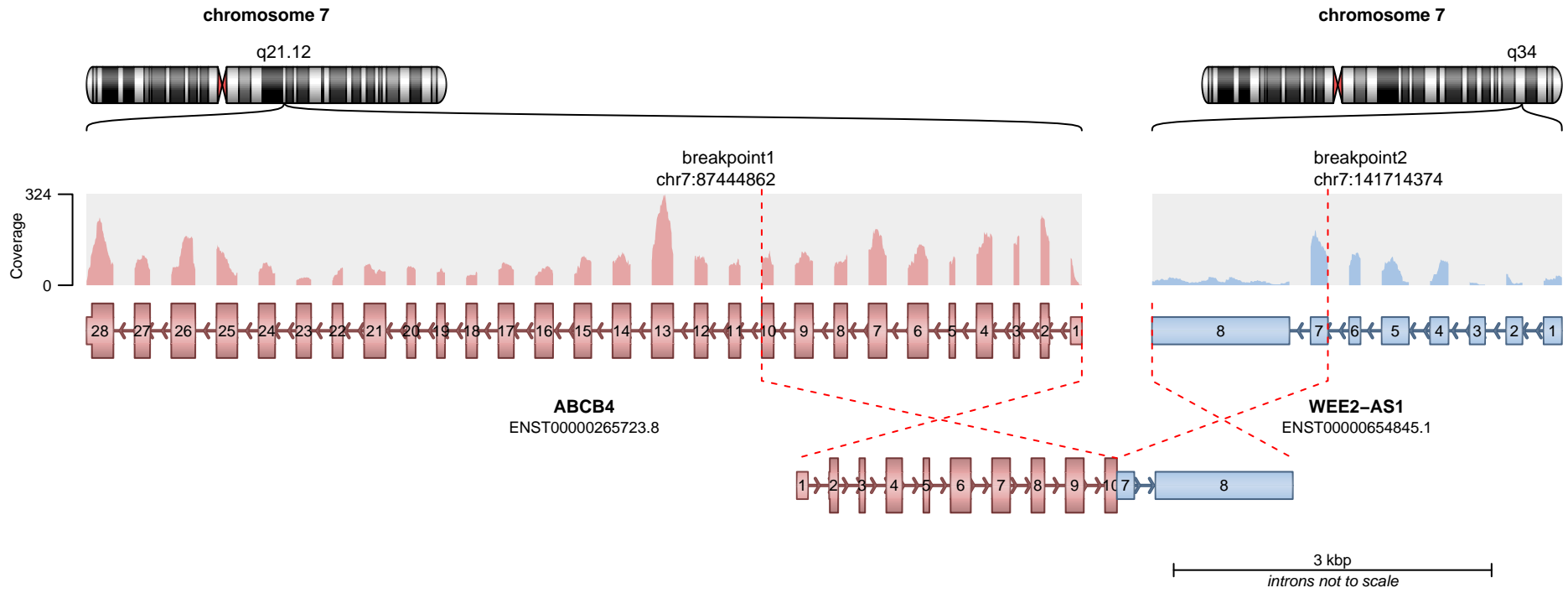

**RETAINED PROTEIN DOMAINS**  
reading frame unclear

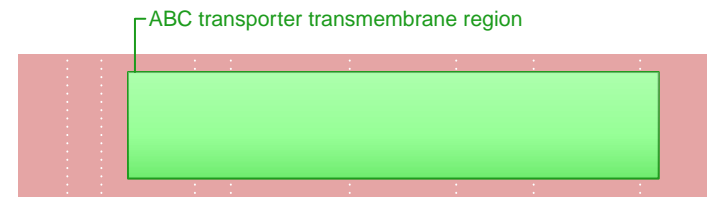

**SUPPORTING READ COUNT**

Split reads = 2  
Discordant mates = 0

- translocation
- duplication
- deletion
- inversion

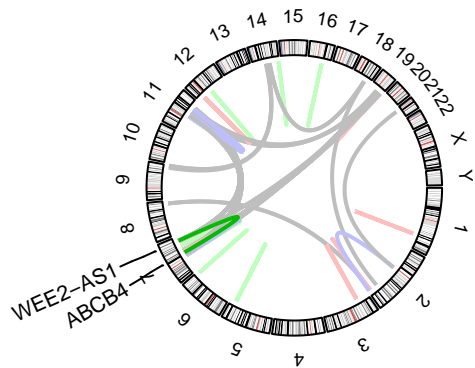
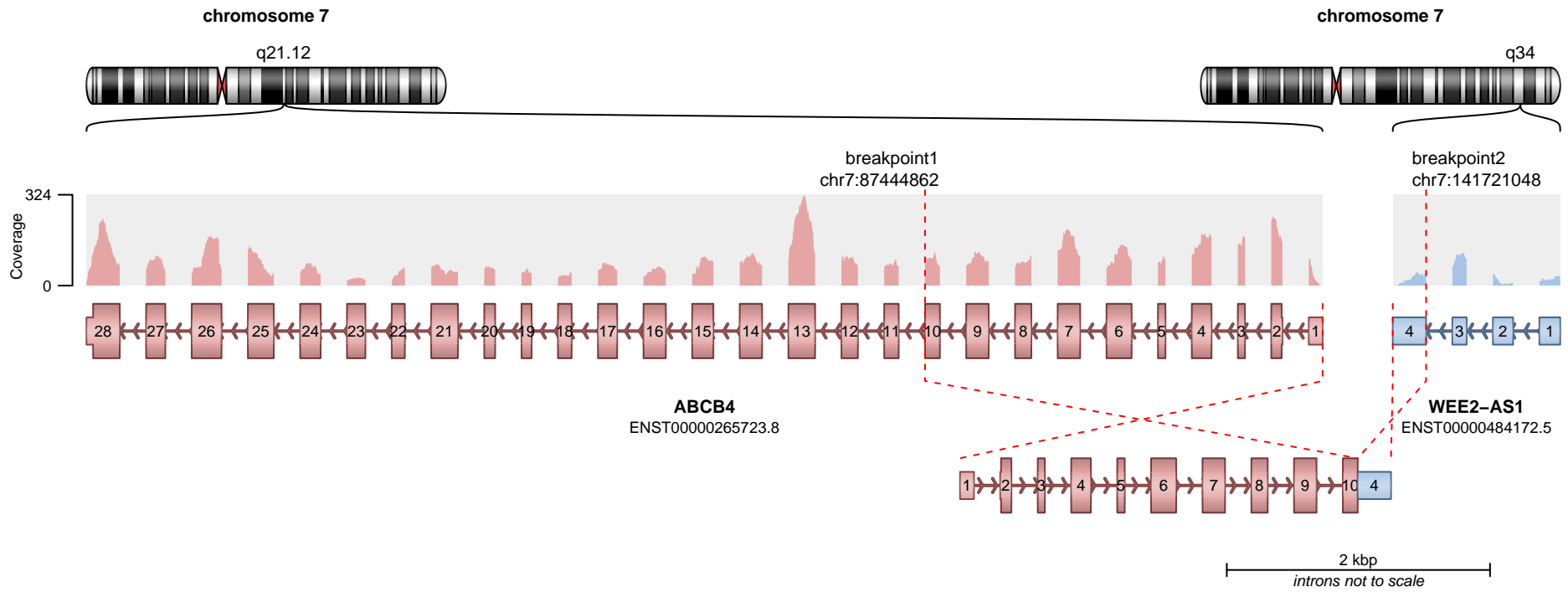

**RETAINED PROTEIN DOMAINS**  
reading frame unclear

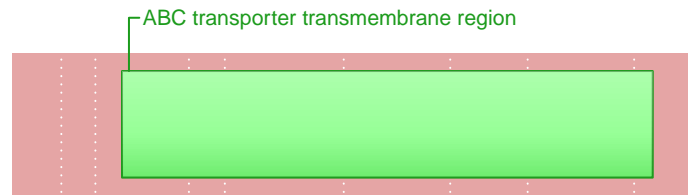

**SUPPORTING READ COUNT**

Split reads = 1  
Discordant mates = 0

- translocation
- duplication
- deletion
- inversion

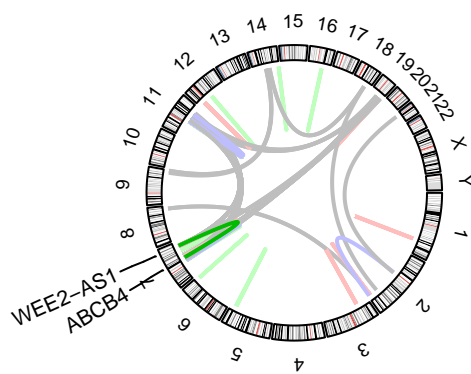
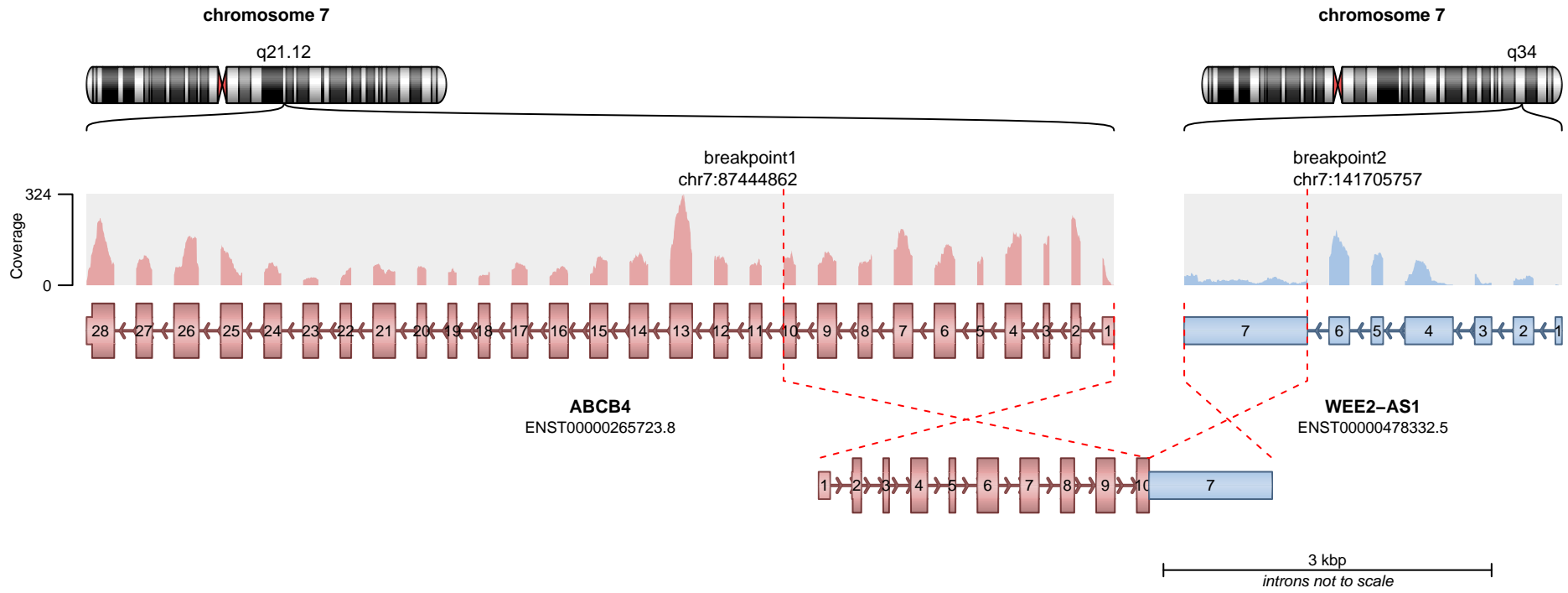

**RETAINED PROTEIN DOMAINS**  
reading frame unclear

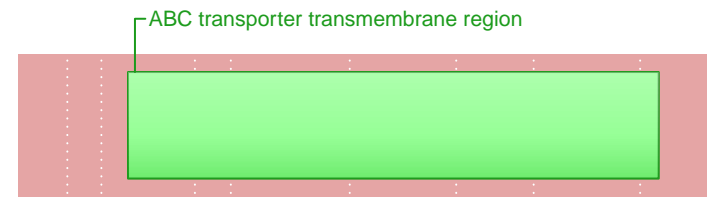

**ABCB4**

**SUPPORTING READ COUNT**

Split reads = 1  
Discordant mates = 0

— translocation    — deletion  
— duplication    — inversion

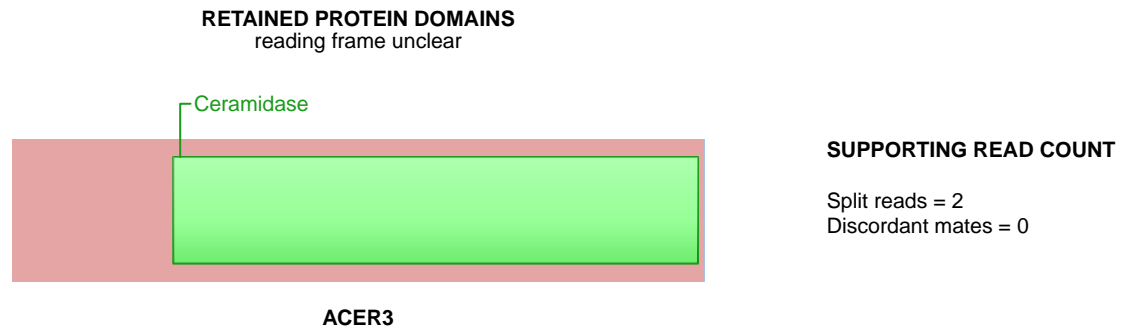
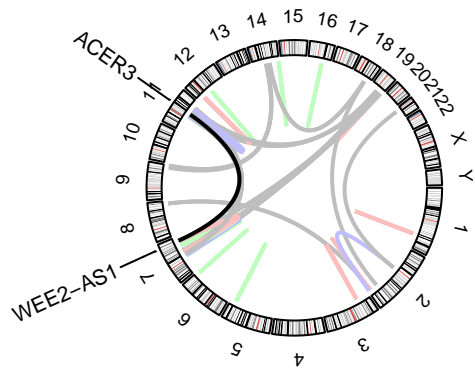
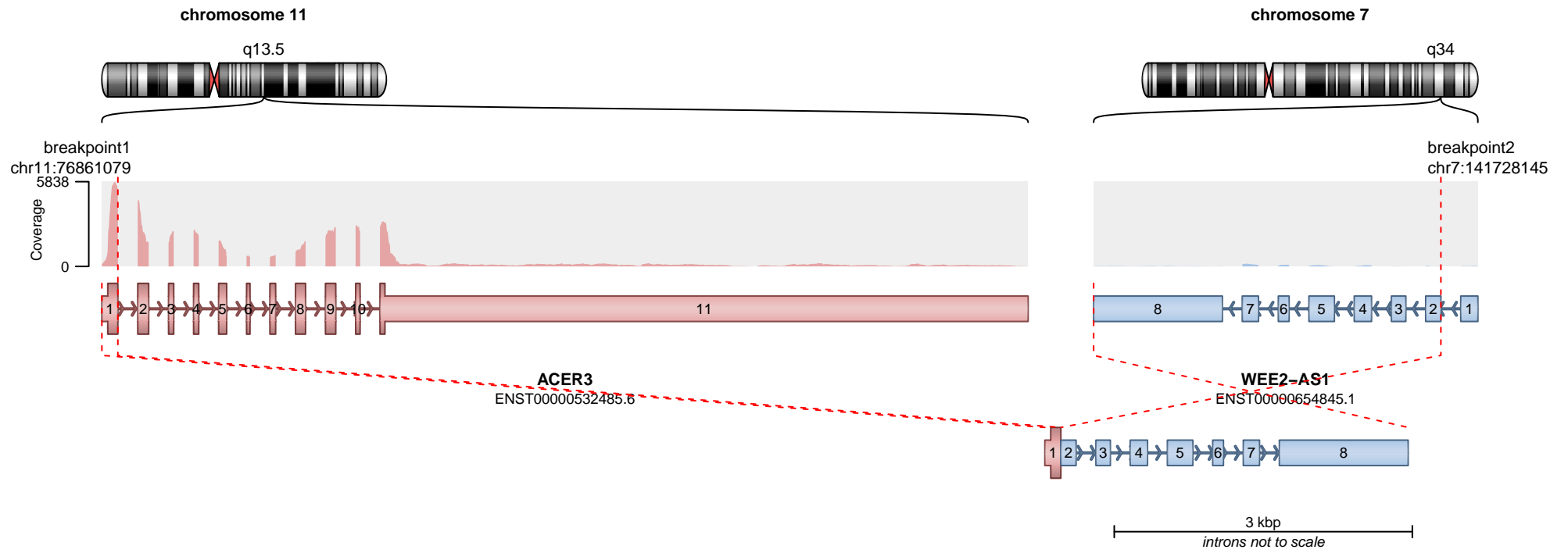

— translocation    — deletion  
— duplication    — inversion

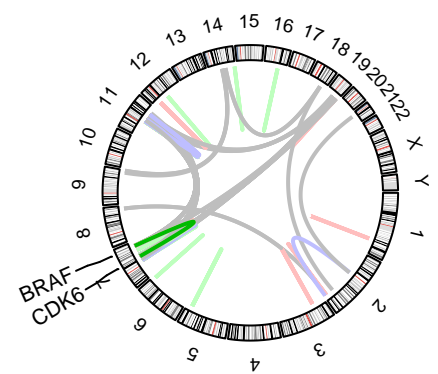
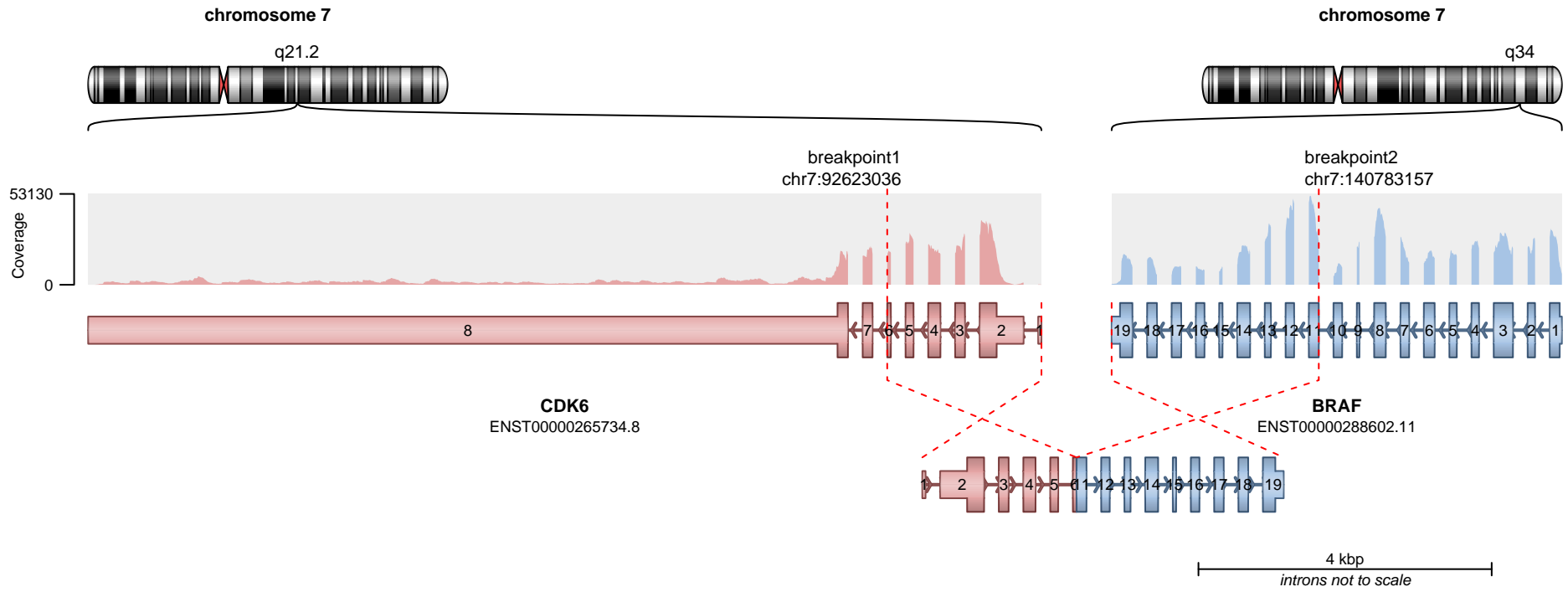

**RETAINED PROTEIN DOMAINS**  
reading frame unclear

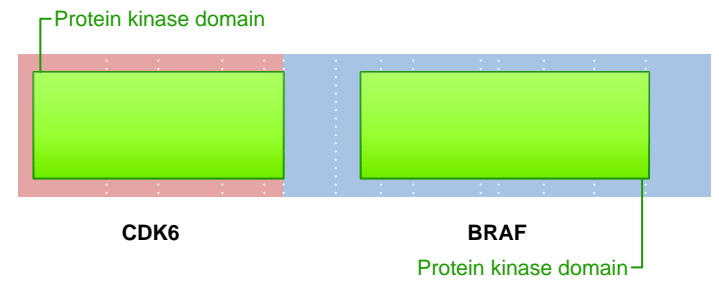

**SUPPORTING READ COUNT**

Split reads = 2  
Discordant mates = 0

- translocation
- duplication
- deletion
- inversion

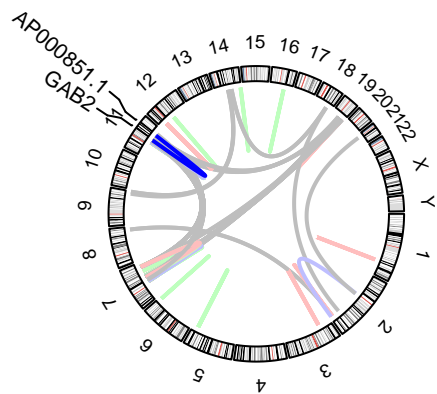
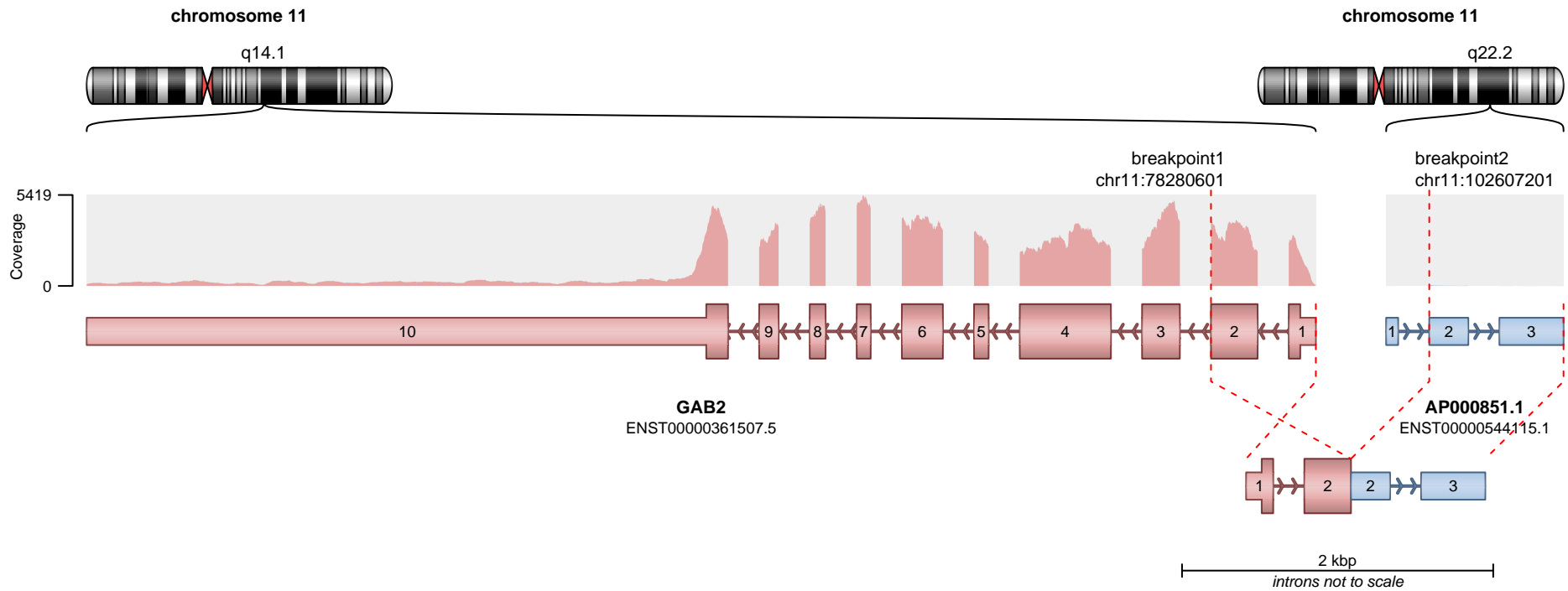

**RETAINED PROTEIN DOMAINS**  
reading frame unclear

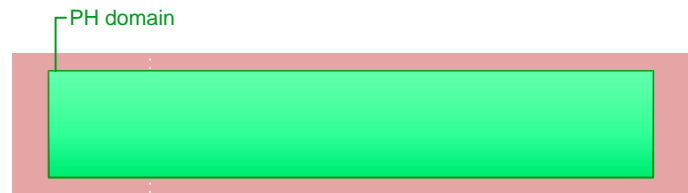

**GAB2**

**SUPPORTING READ COUNT**

Split reads = 2  
Discordant mates = 0

- translocation
- duplication
- deletion
- inversion

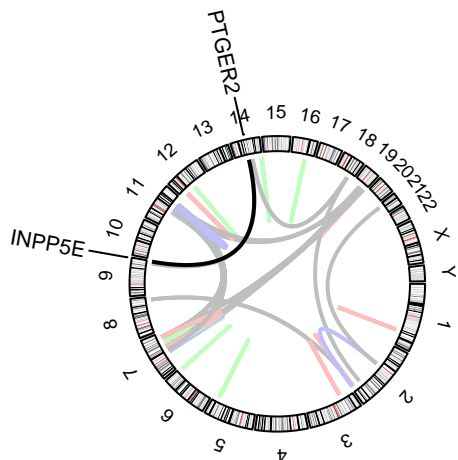
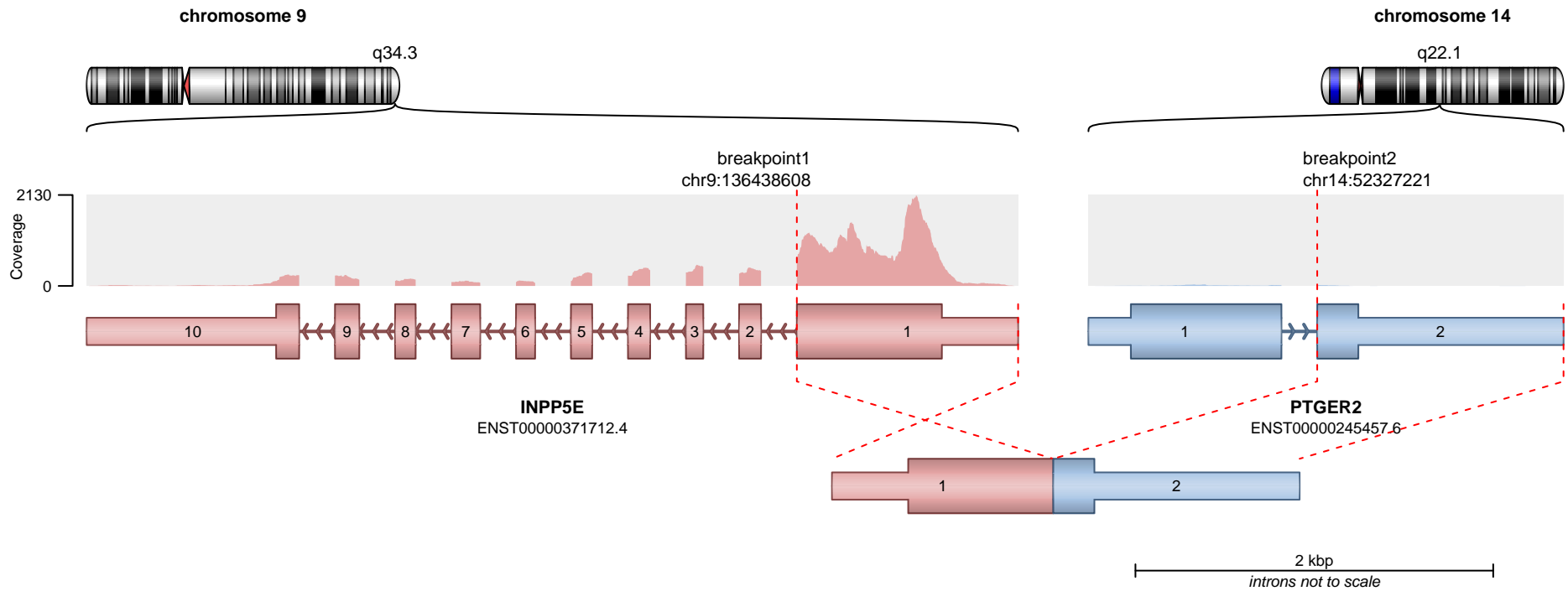

**RETAINED PROTEIN DOMAINS**  
reading frame unclear

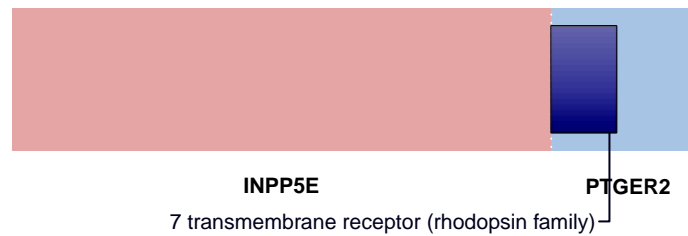

**SUPPORTING READ COUNT**

Split reads = 2  
Discordant mates = 0

— translocation    — deletion  
— duplication    — inversion

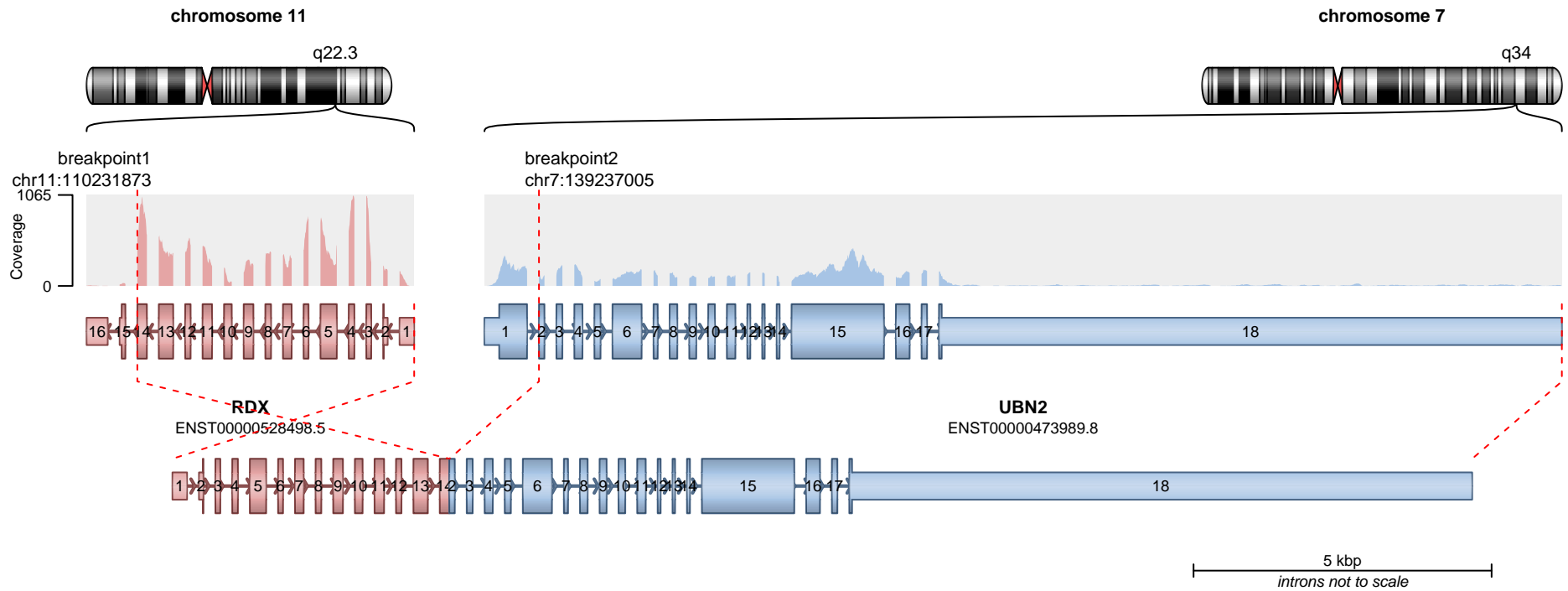

**RETAINED PROTEIN DOMAINS**  
reading frame unclear

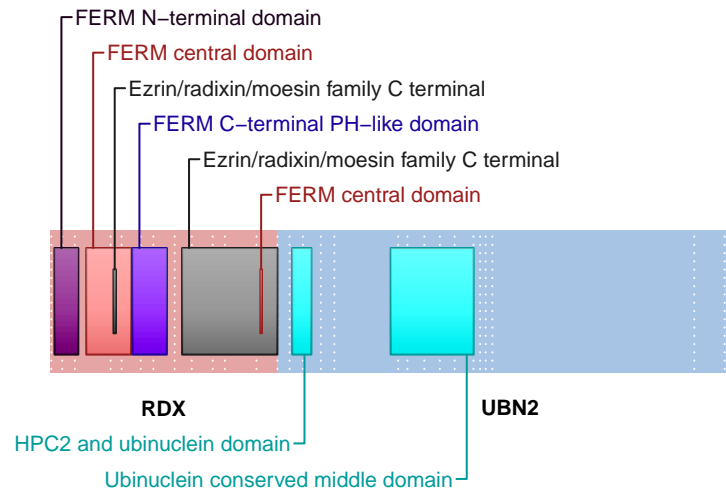
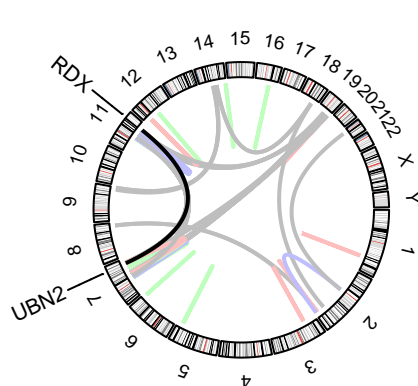

**SUPPORTING READ COUNT**

Split reads = 2  
Discordant mates = 0

- translocation
- duplication
- deletion
- inversion

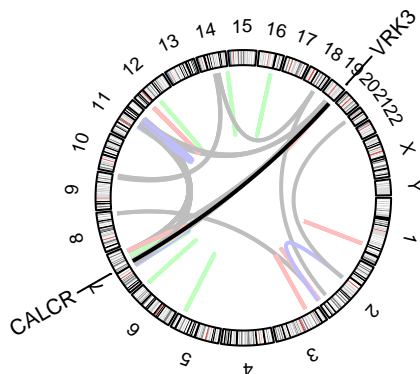
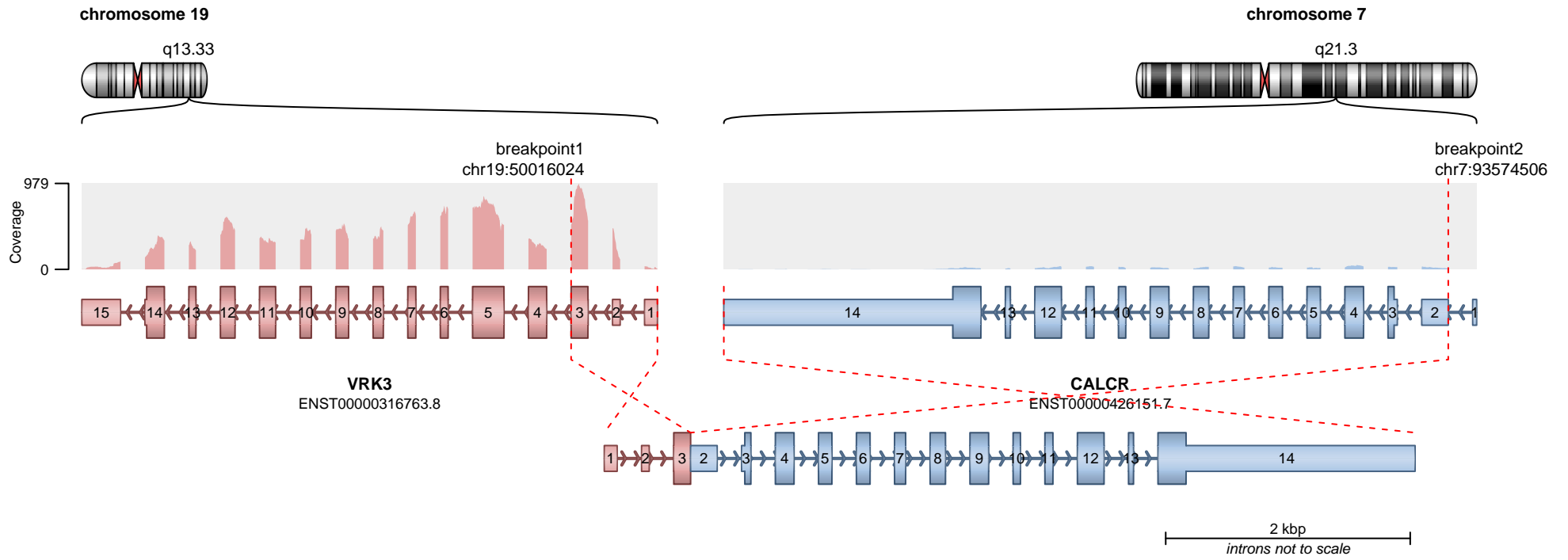

**RETAINED PROTEIN DOMAINS**  
reading frame unclear

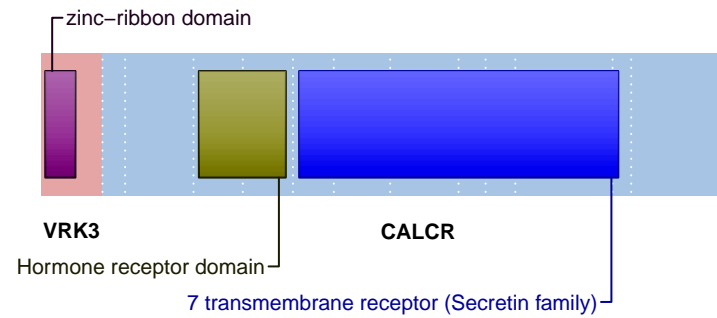

**SUPPORTING READ COUNT**

Split reads = 2  
Discordant mates = 0

- translocation
- duplication
- deletion
- inversion

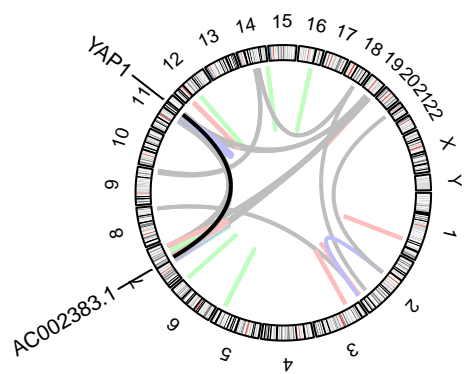
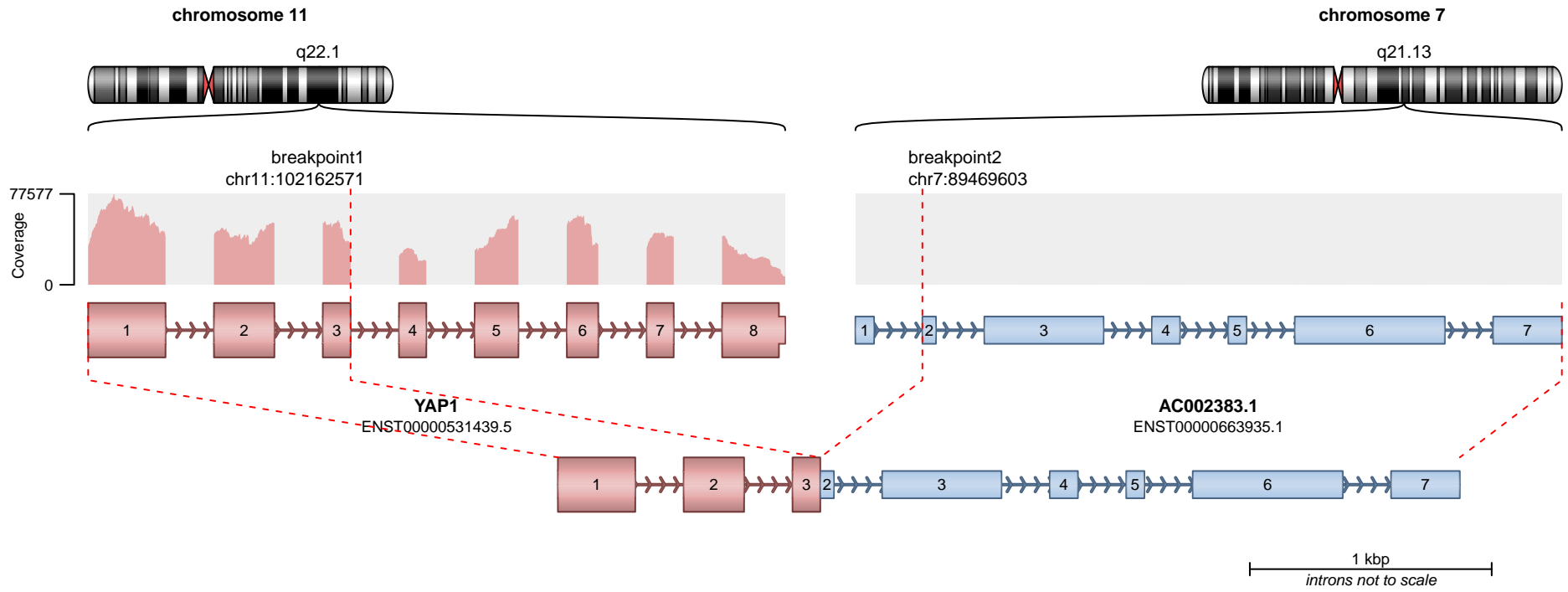

- translocation
- duplication
- deletion
- inversion

**RETAINED PROTEIN DOMAINS**  
reading frame unclear

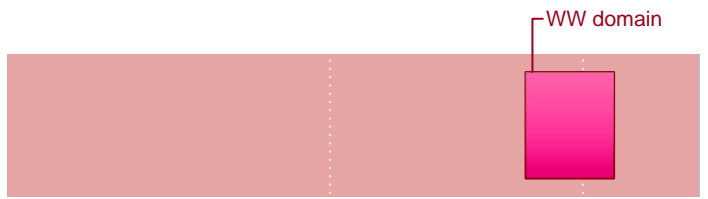

YAP1

**SUPPORTING READ COUNT**

Split reads = 2  
Discordant mates = 0

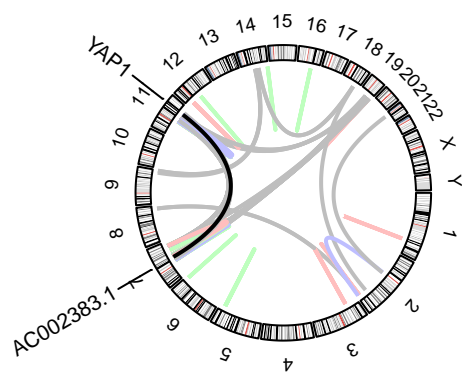
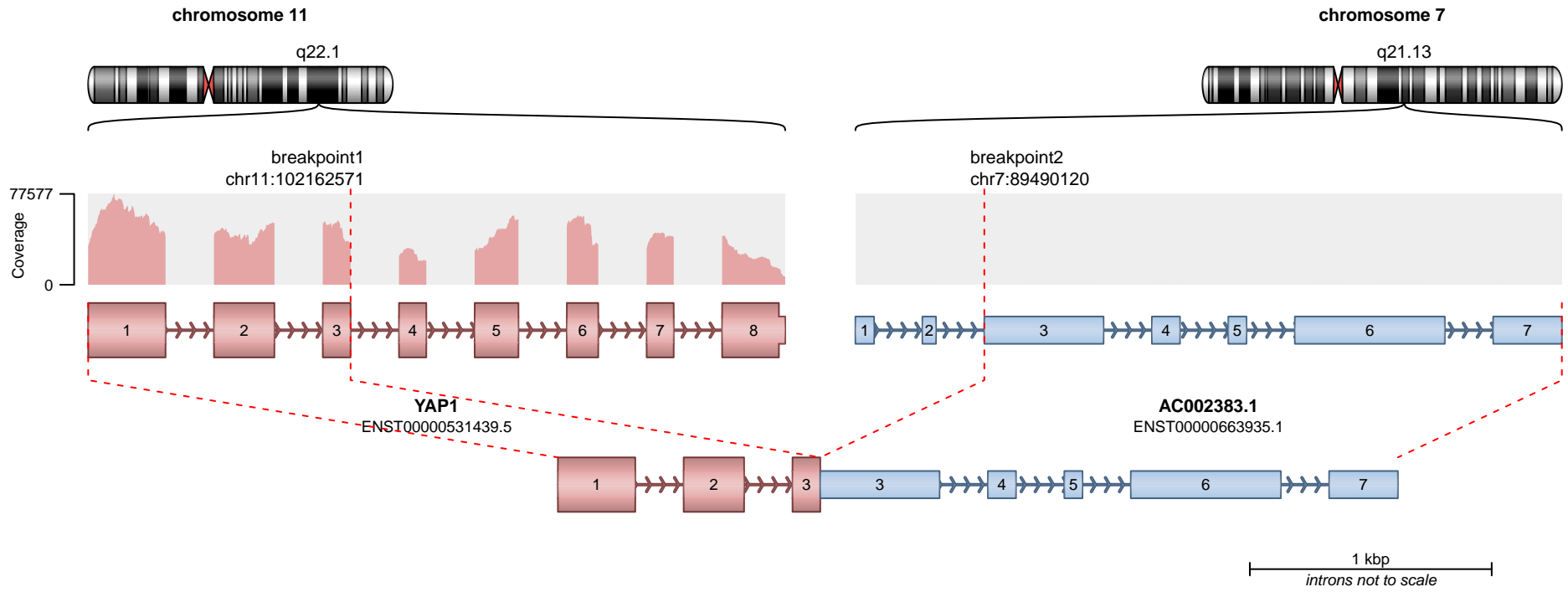

— translocation    — deletion  
— duplication      — inversion

**RETAINED PROTEIN DOMAINS**  
reading frame unclear

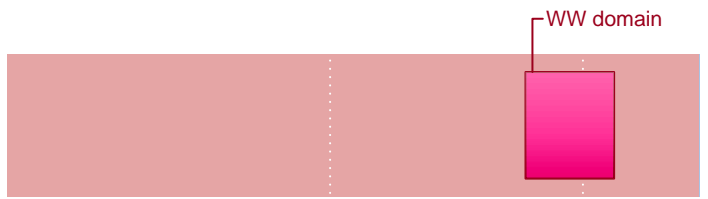

**SUPPORTING READ COUNT**

Split reads = 1  
Discordant mates = 0

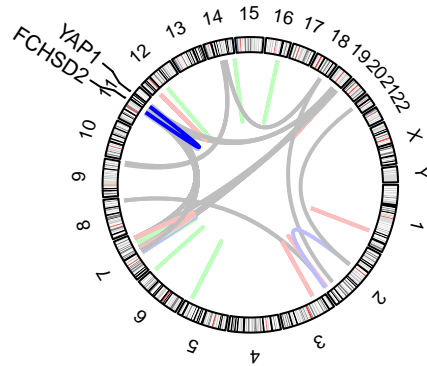
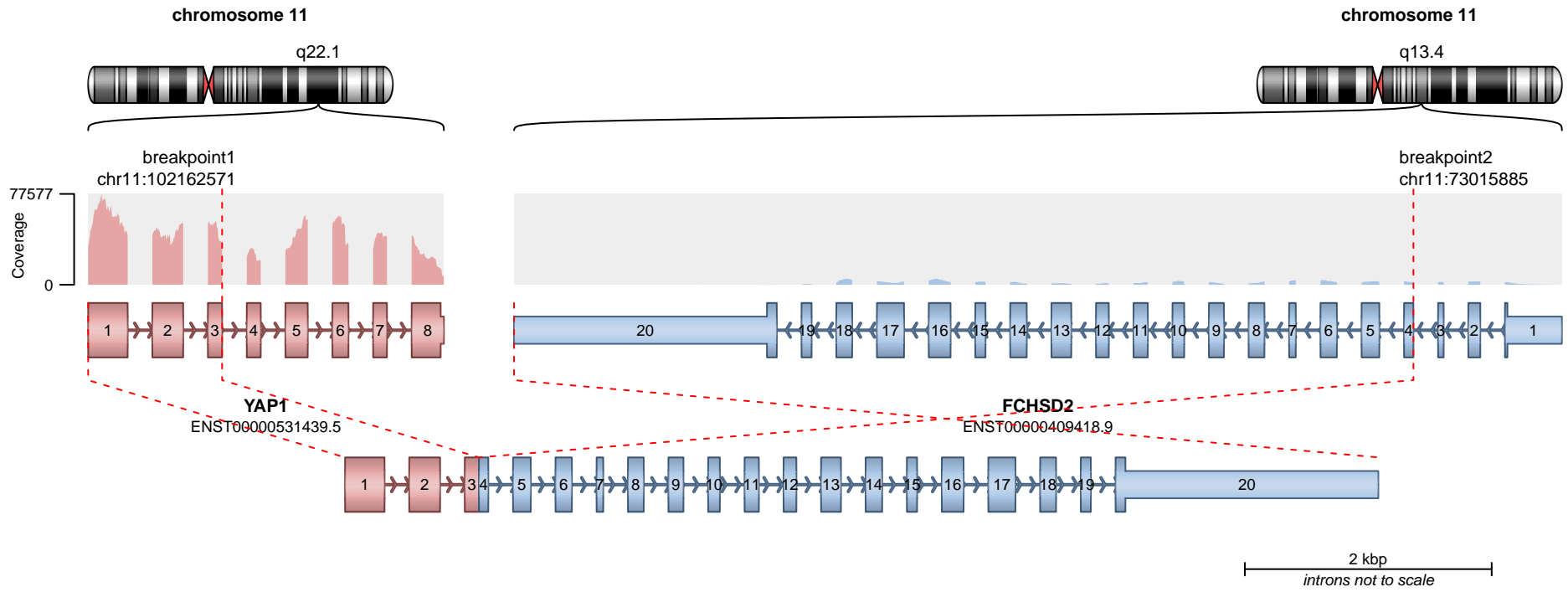

**RETAINED PROTEIN DOMAINS**  
reading frame unclear

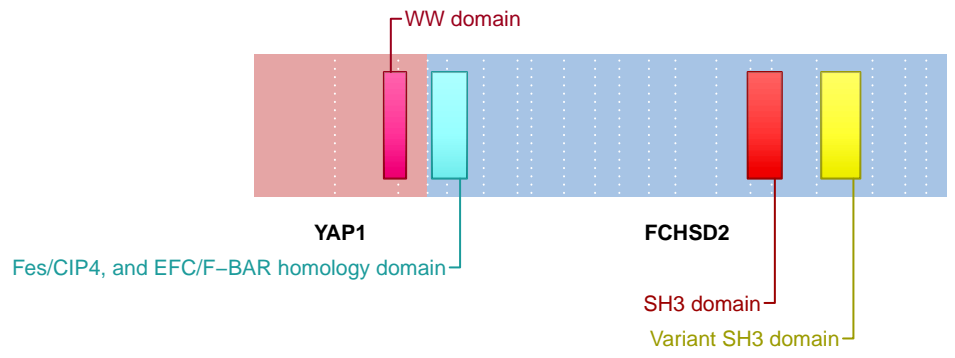

**SUPPORTING READ COUNT**

Split reads = 1  
Discordant mates = 1

- translocation
- duplication
- deletion
- inversion

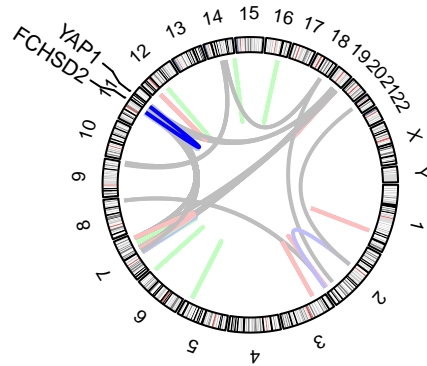
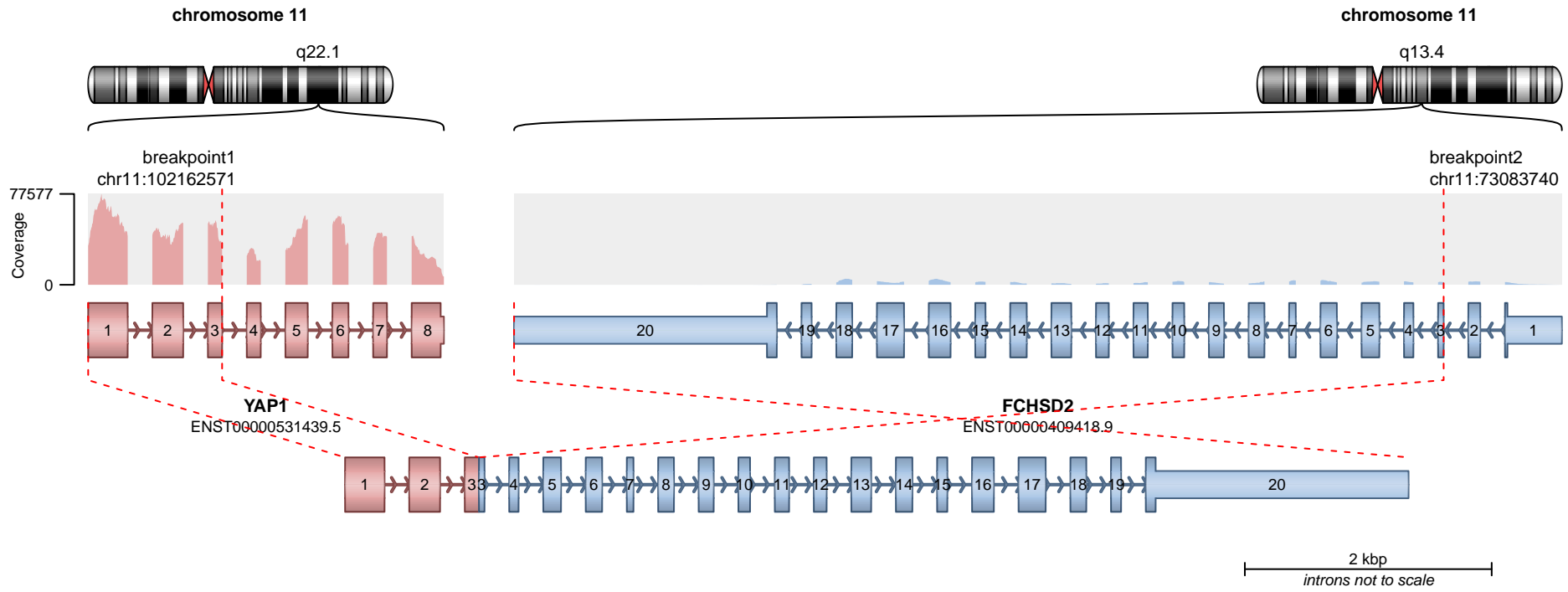

**RETAINED PROTEIN DOMAINS**  
reading frame unclear

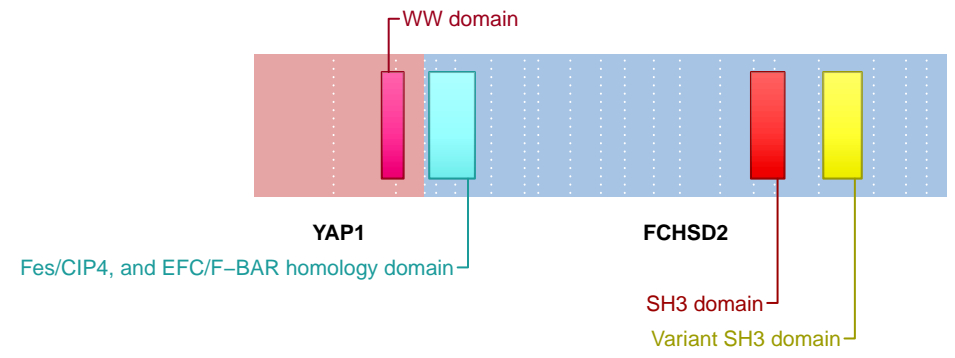

**SUPPORTING READ COUNT**

Split reads = 1  
Discordant mates = 1

- translocation
- duplication
- deletion
- inversion

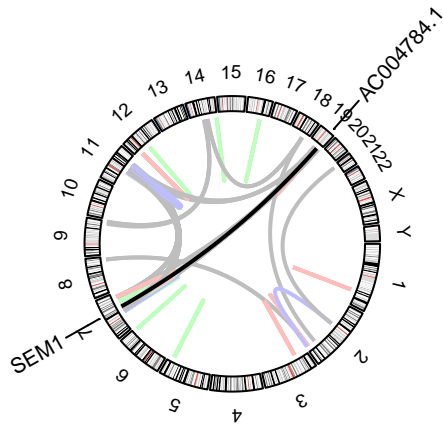
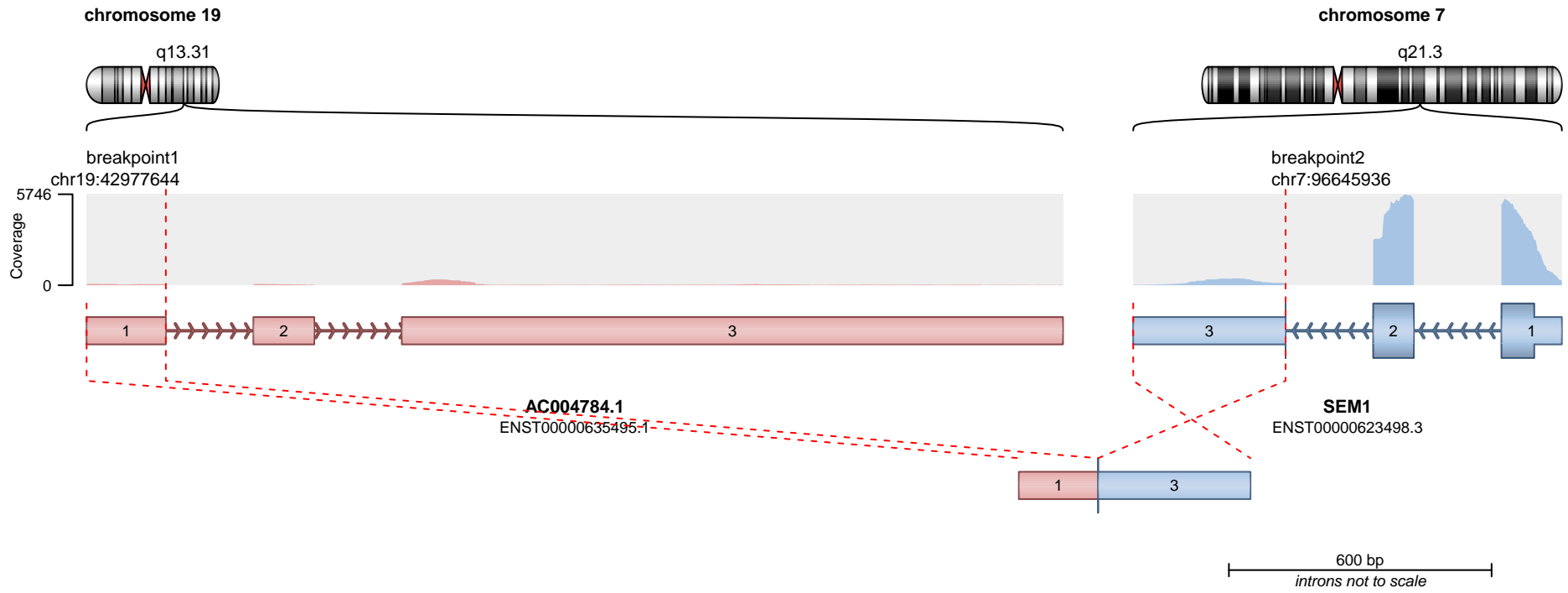

**RETAINED PROTEIN DOMAINS**  
reading frame unclear

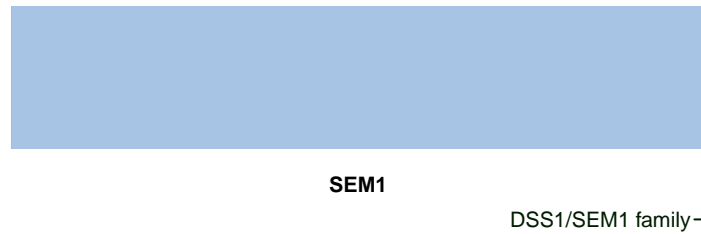

**SUPPORTING READ COUNT**

Split reads = 1  
Discordant mates = 0

— translocation — deletion  
— duplication — inversion

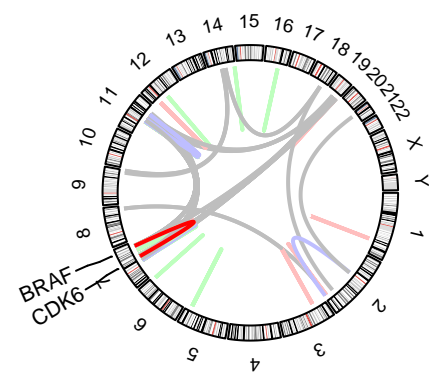
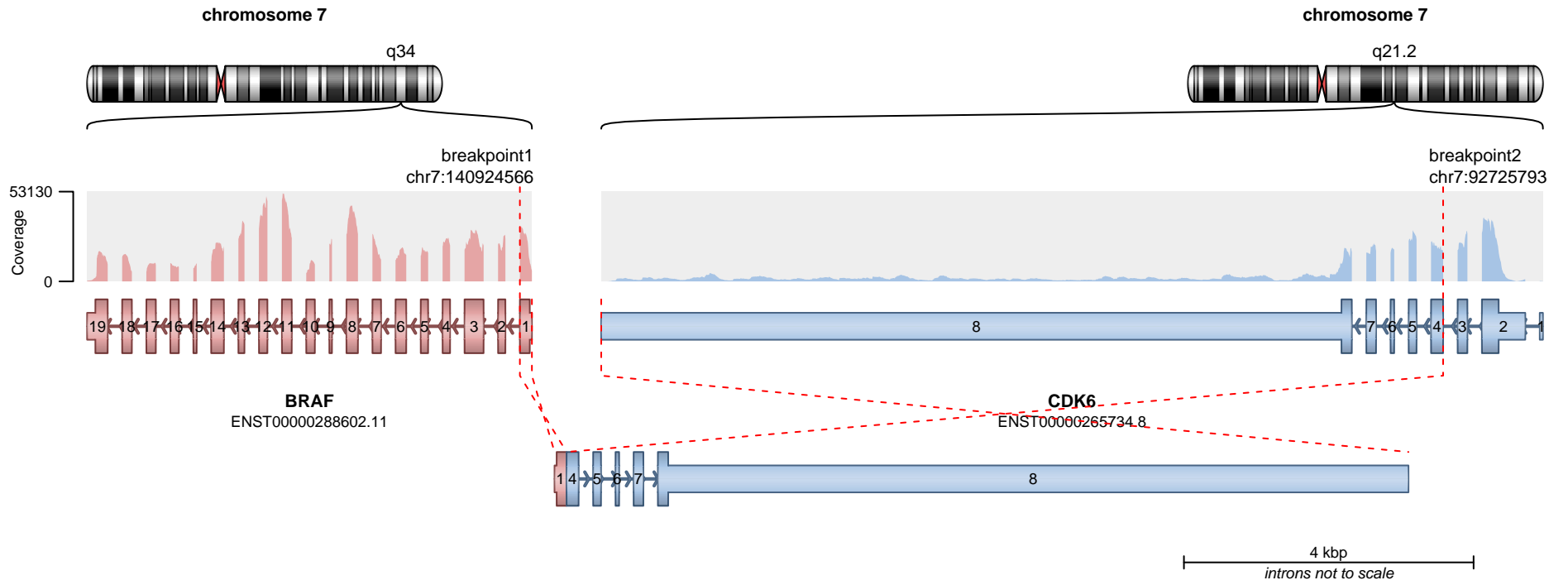

— translocation    — deletion  
— duplication    — inversion

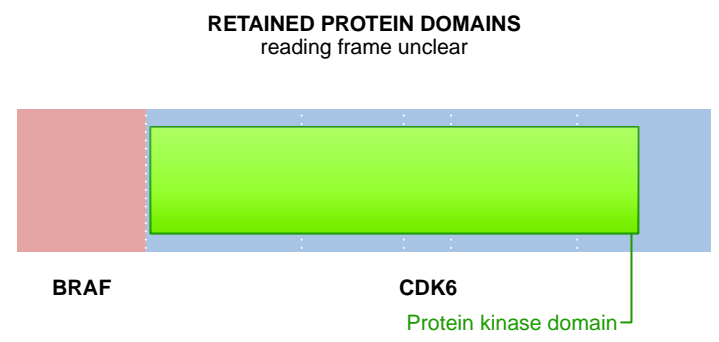

**SUPPORTING READ COUNT**

Split reads = 1  
Discordant mates = 0

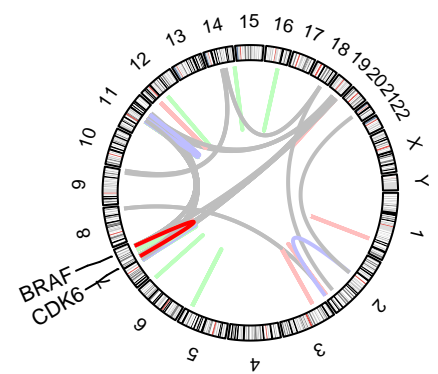
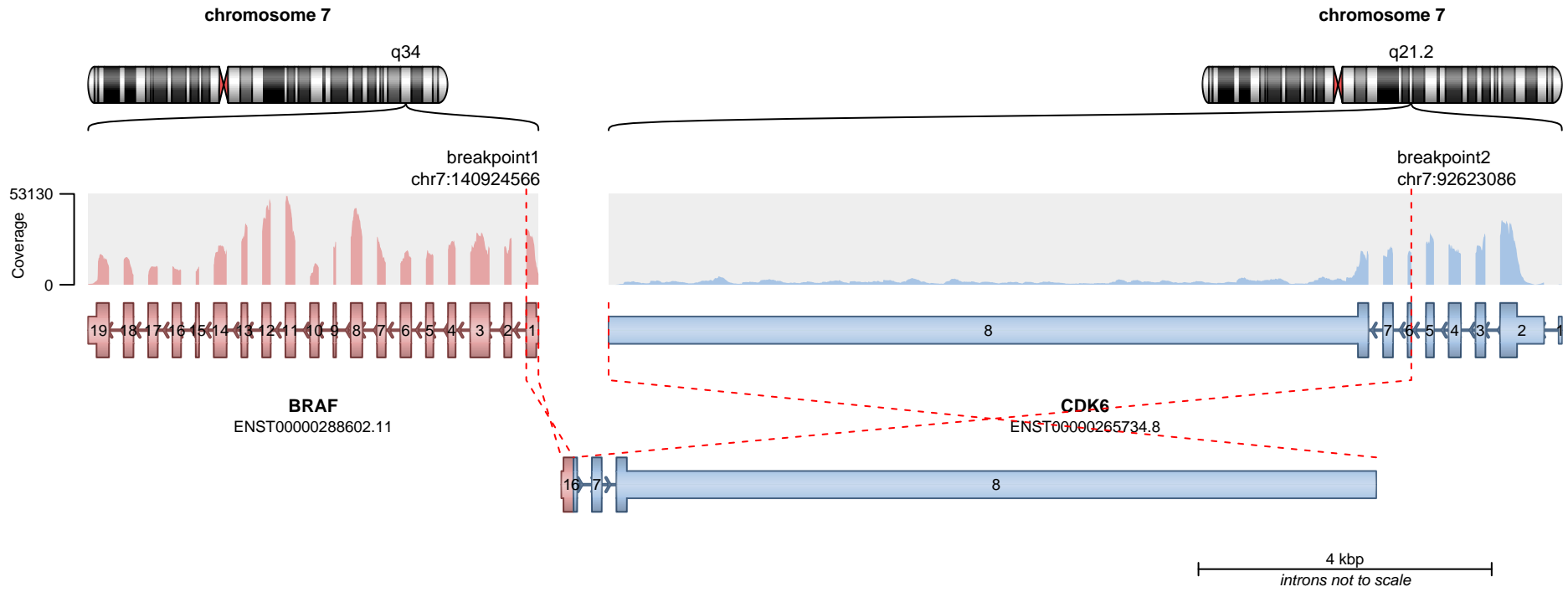

— translocation    — deletion  
— duplication    — inversion

**RETAINED PROTEIN DOMAINS**  
reading frame unclear



**SUPPORTING READ COUNT**

Split reads = 1  
Discordant mates = 0

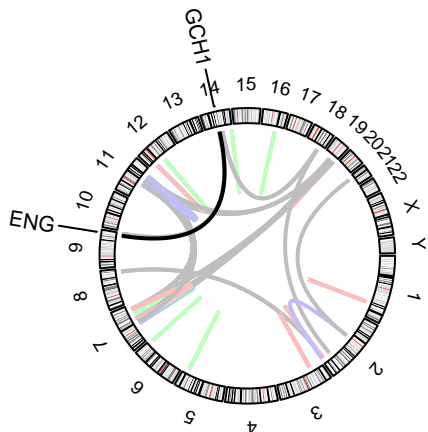
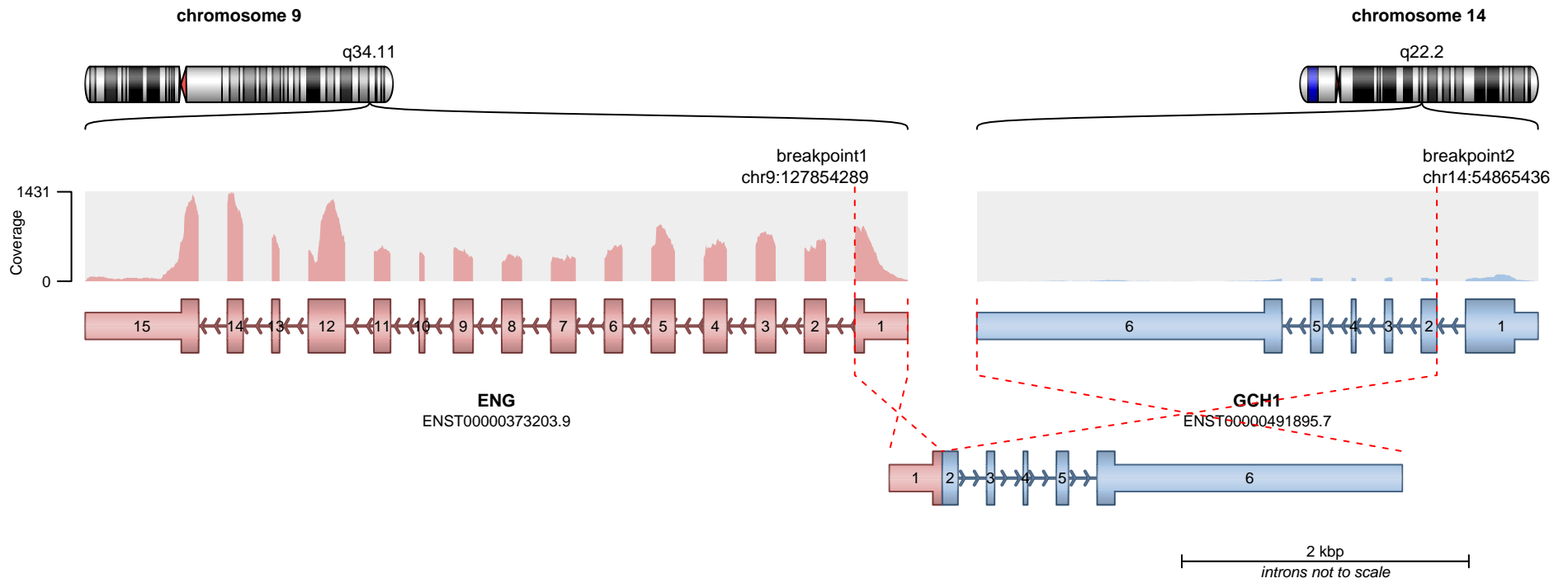

**RETAINED PROTEIN DOMAINS**  
reading frame unclear

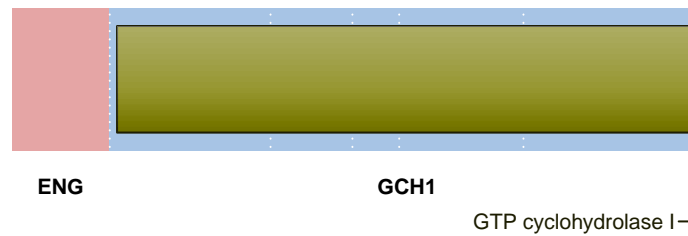

**SUPPORTING READ COUNT**

Split reads = 1  
Discordant mates = 0

— translocation — deletion  
— duplication — inversion

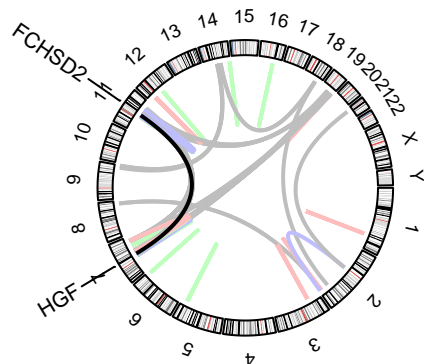
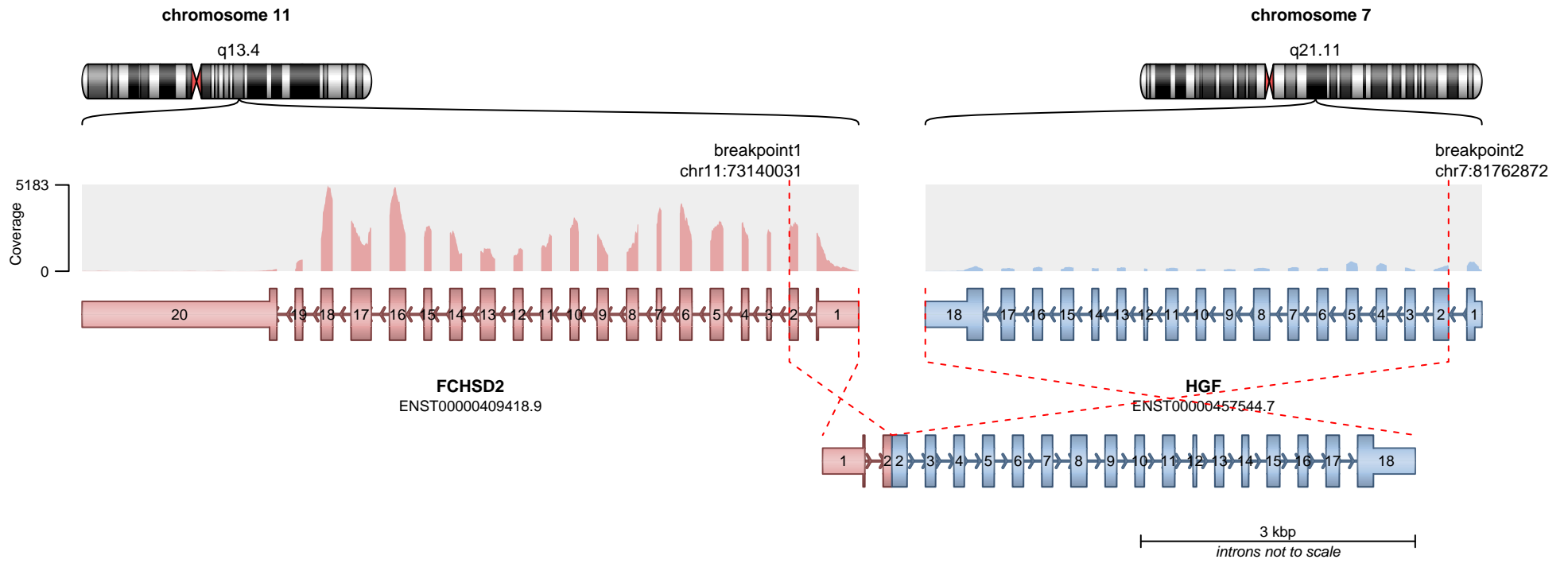

— translocation — deletion  
— duplication — inversion

**RETAINED PROTEIN DOMAINS**  
reading frame unclear

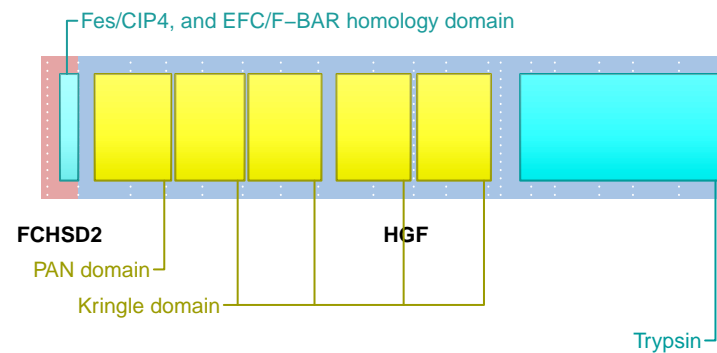

**SUPPORTING READ COUNT**

Split reads = 1  
Discordant mates = 0