

RETAINED PROTEIN DOMAINS
reading frame unclear

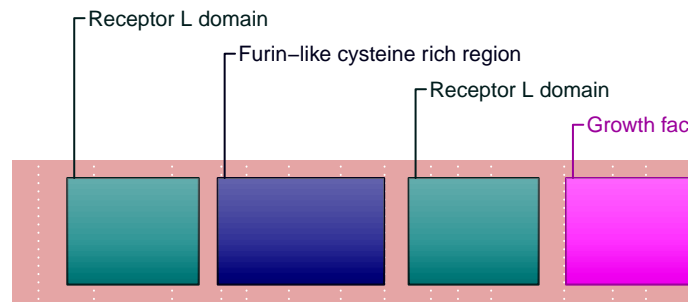

ERBB2

SUPPORTING READ COUNT

Split reads = 4252
Discordant mates = 0

— translocation — deletion
— duplication — inversion

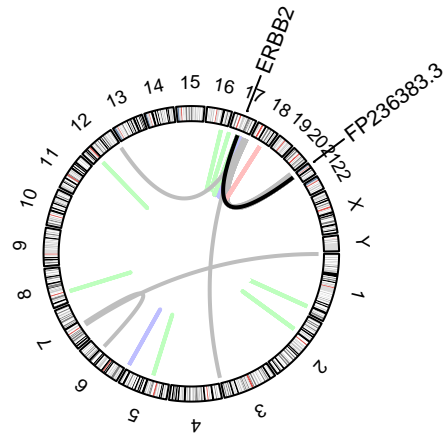
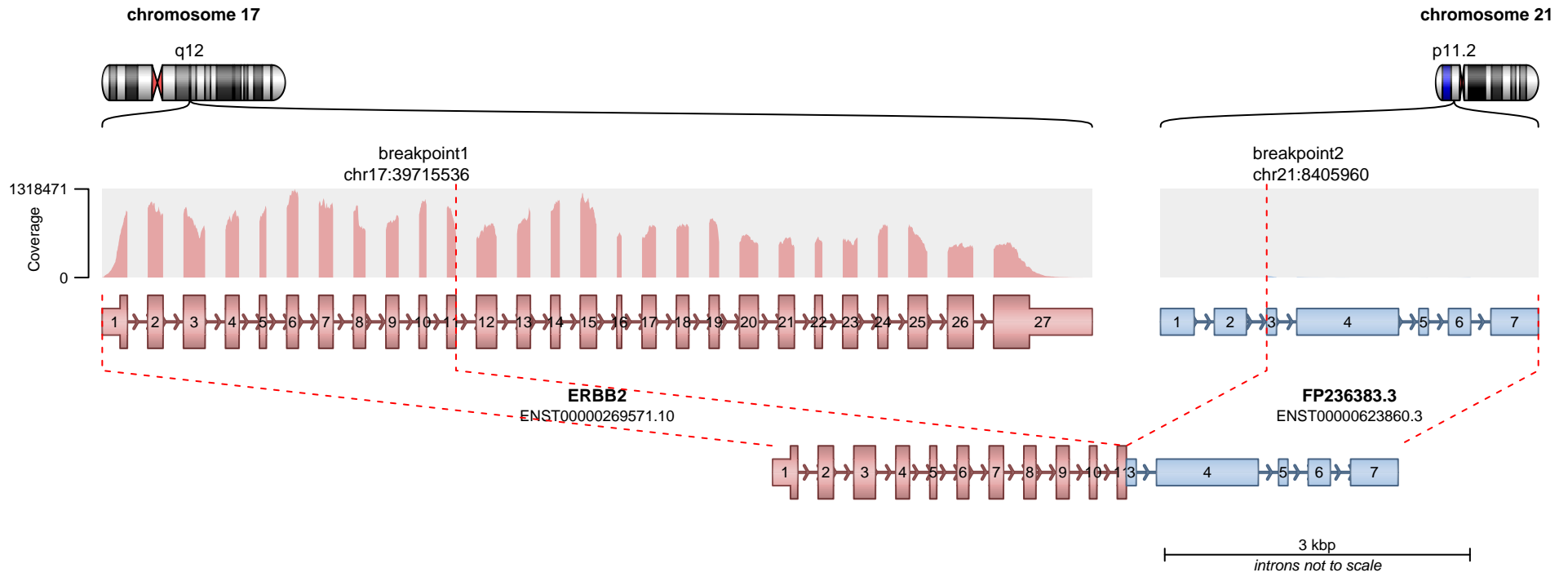

RETAINED PROTEIN DOMAINS
reading frame unclear

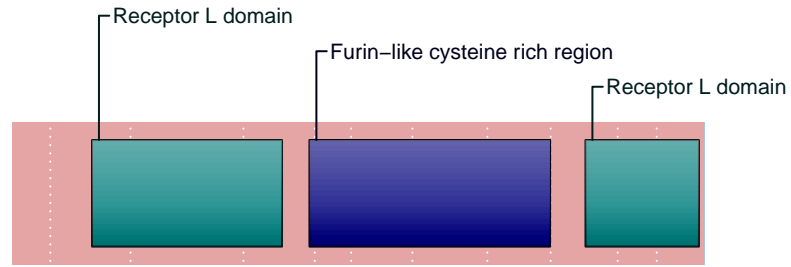

ERBB2

SUPPORTING READ COUNT

Split reads = 467
Discordant mates = 0

- translocation
- duplication
- deletion
- inversion

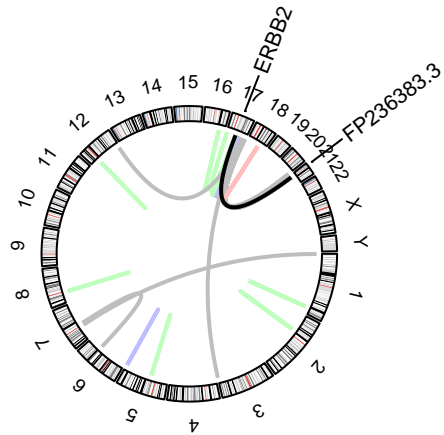
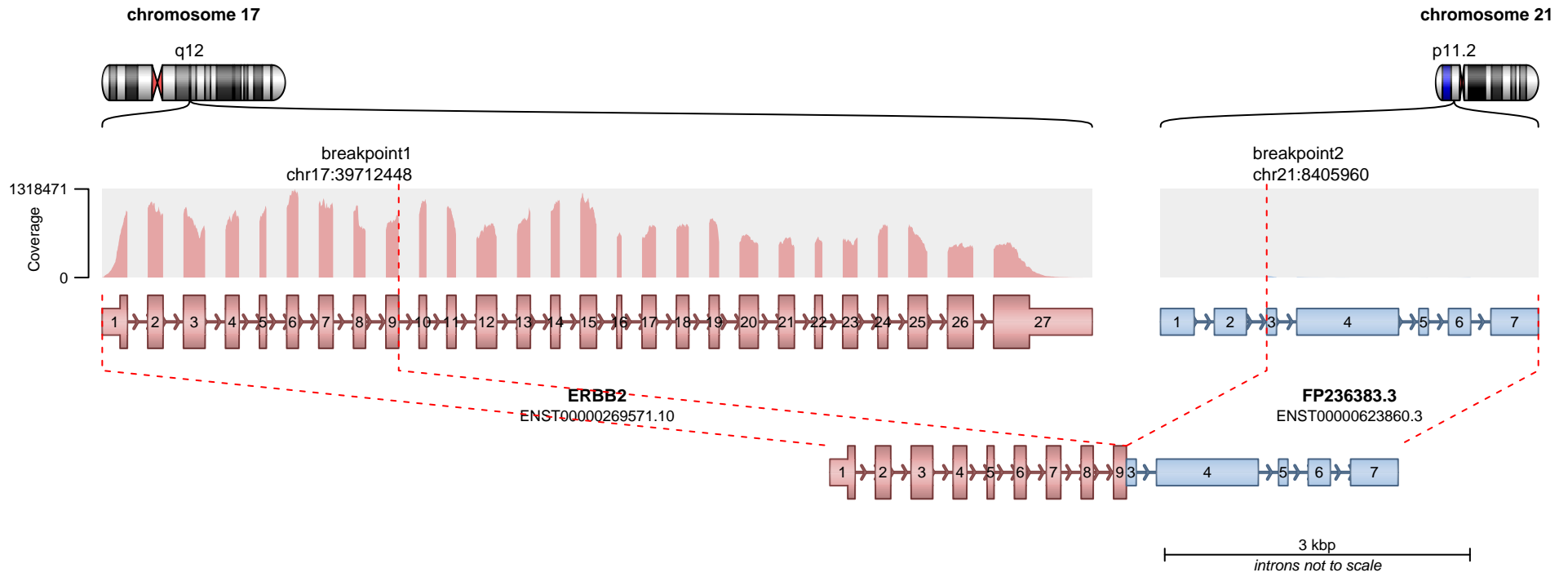

RETAINED PROTEIN DOMAINS
reading frame unclear

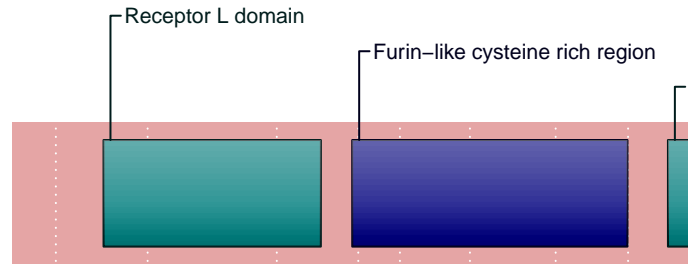

ERBB2

SUPPORTING READ COUNT

Split reads = 107
Discordant mates = 0

- translocation
- duplication
- deletion
- inversion

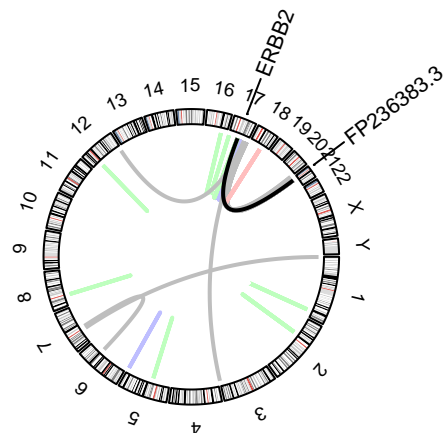
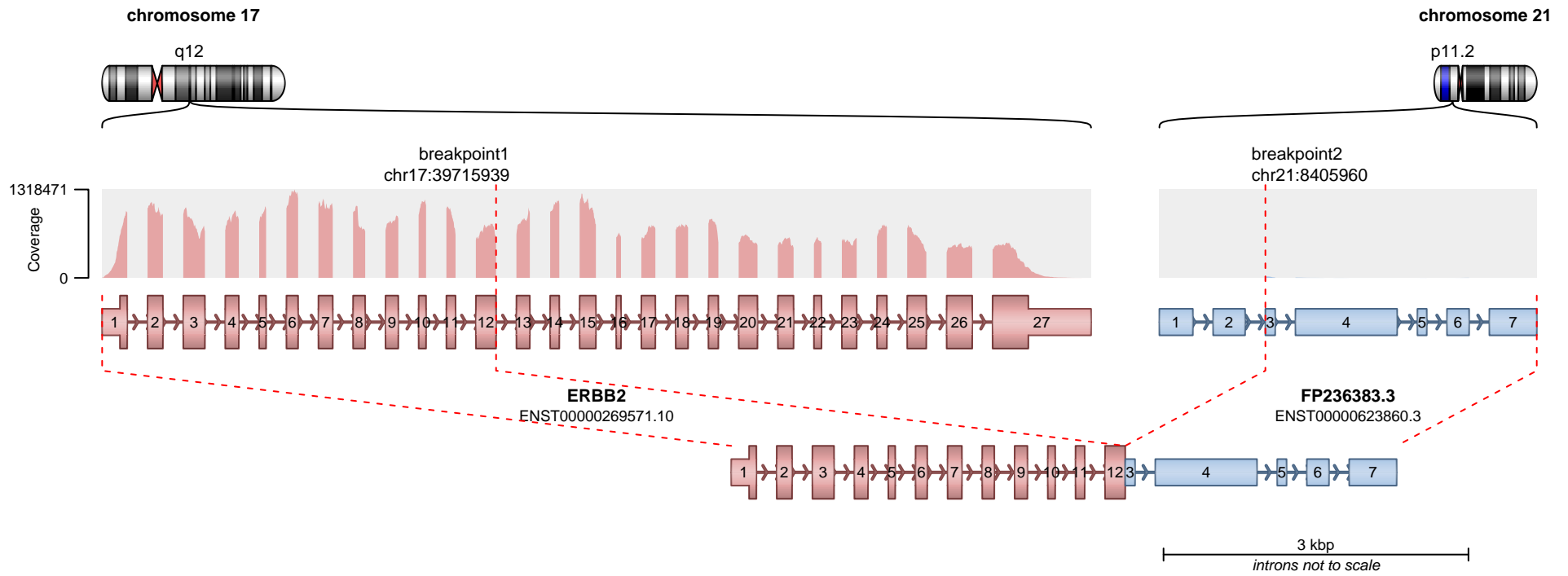

RETAINED PROTEIN DOMAINS
reading frame unclear

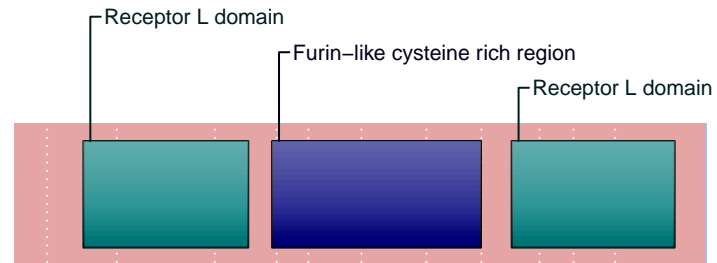

ERBB2

SUPPORTING READ COUNT

Split reads = 39
Discordant mates = 0

— translocation — deletion
— duplication — inversion

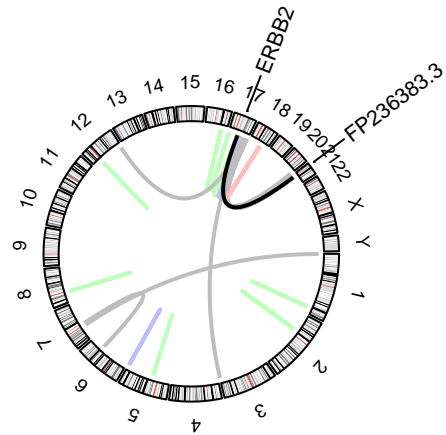
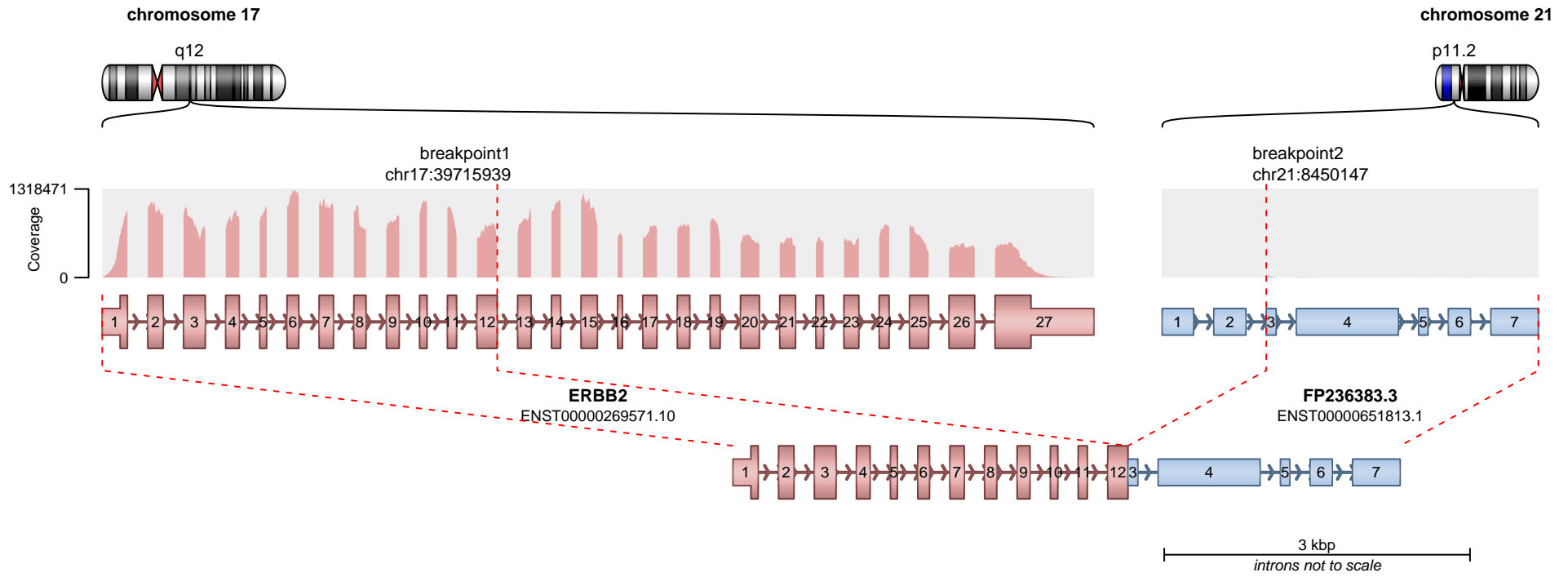

RETAINED PROTEIN DOMAINS
reading frame unclear

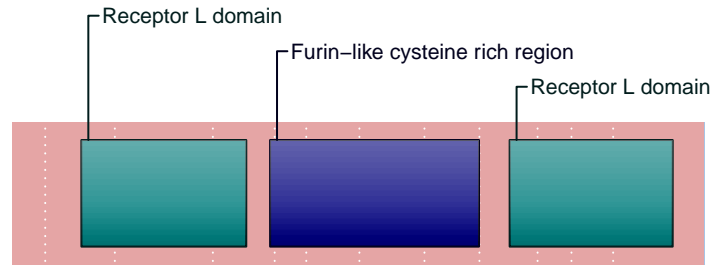

ERBB2

SUPPORTING READ COUNT

Split reads = 39
Discordant mates = 0

— translocation — deletion
— duplication — inversion

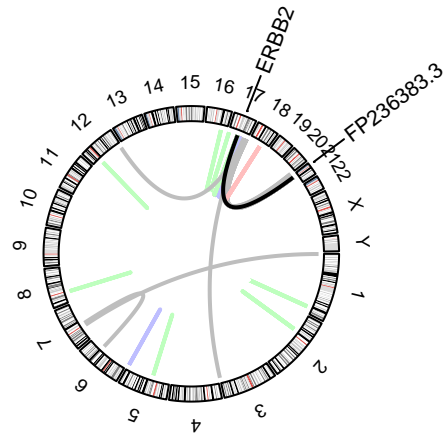
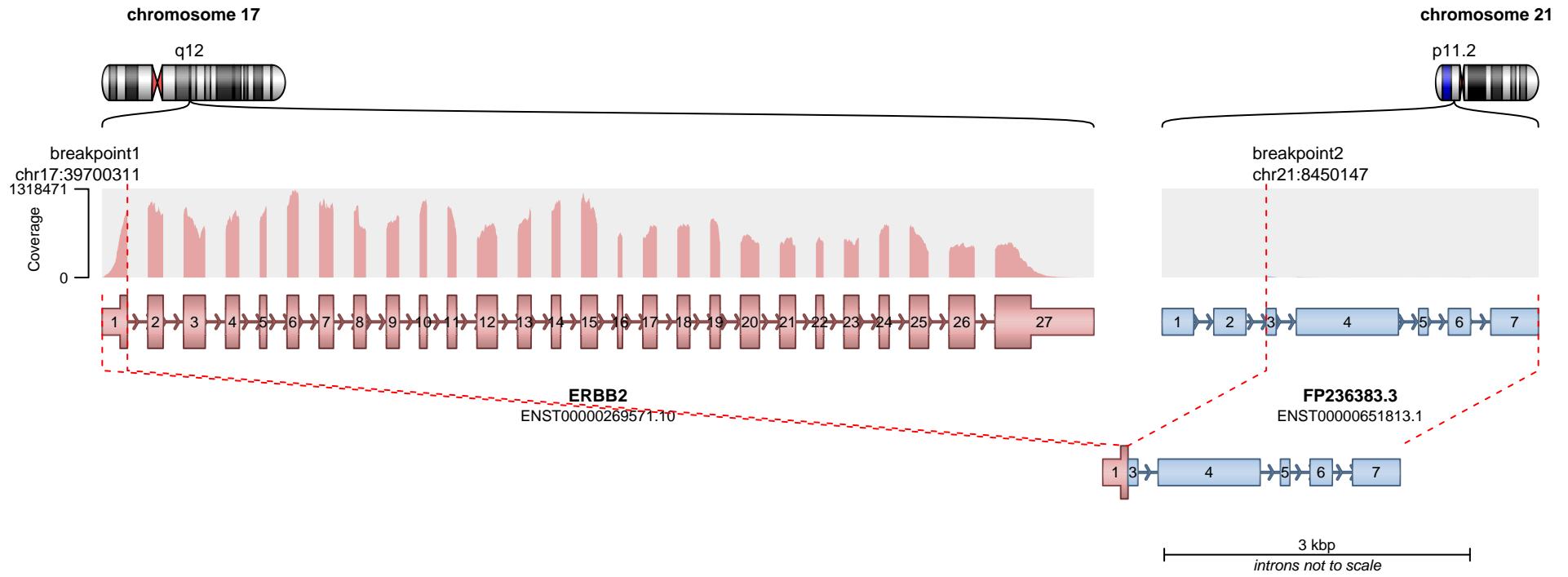

— translocation — deletion
— duplication — inversion

No protein domains retained in fusion.

SUPPORTING READ COUNT

Split reads = 31
Discordant mates = 0

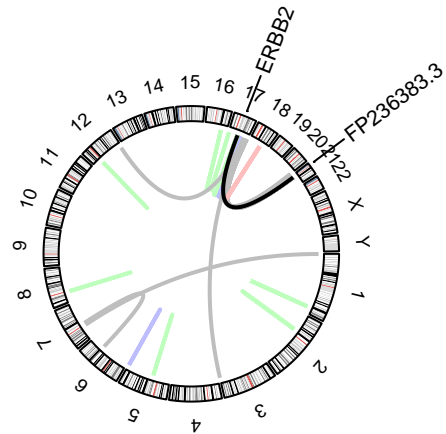
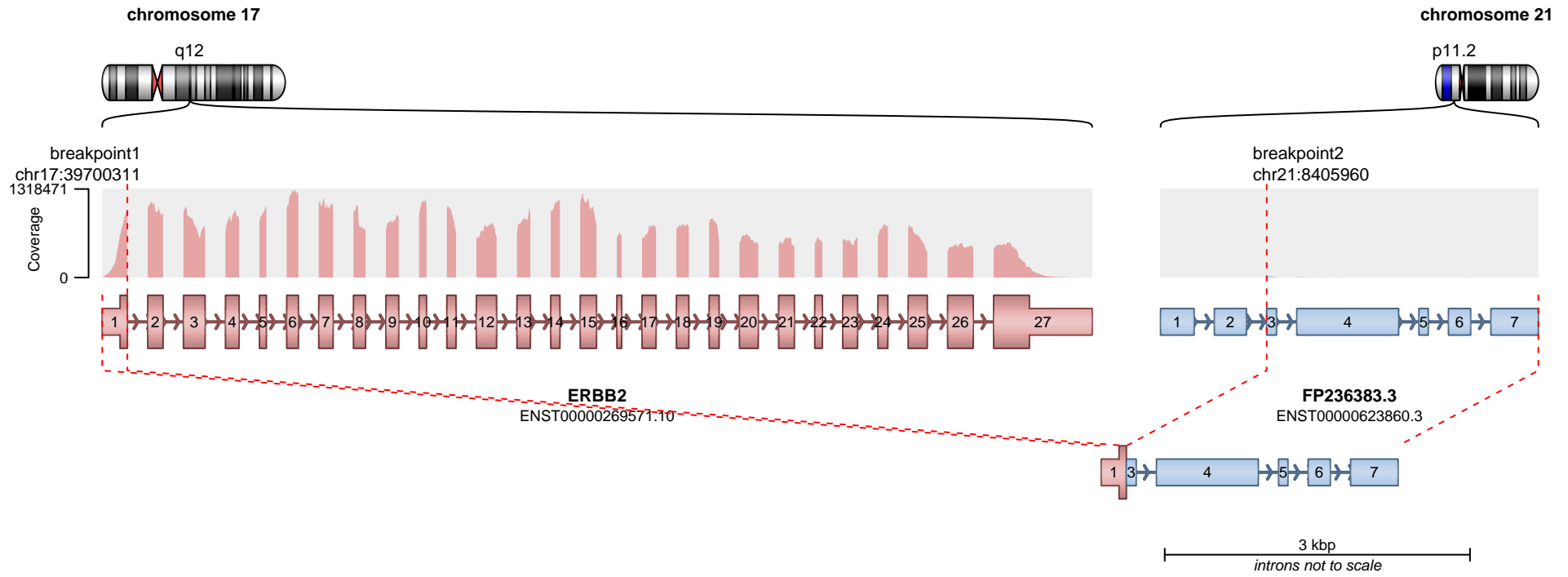

— translocation — deletion
— duplication — inversion

No protein domains retained in fusion.

SUPPORTING READ COUNT

Split reads = 31
Discordant mates = 0

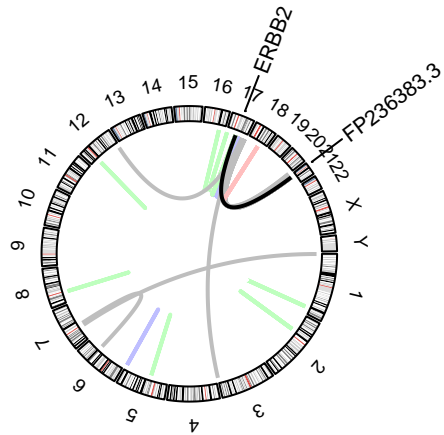
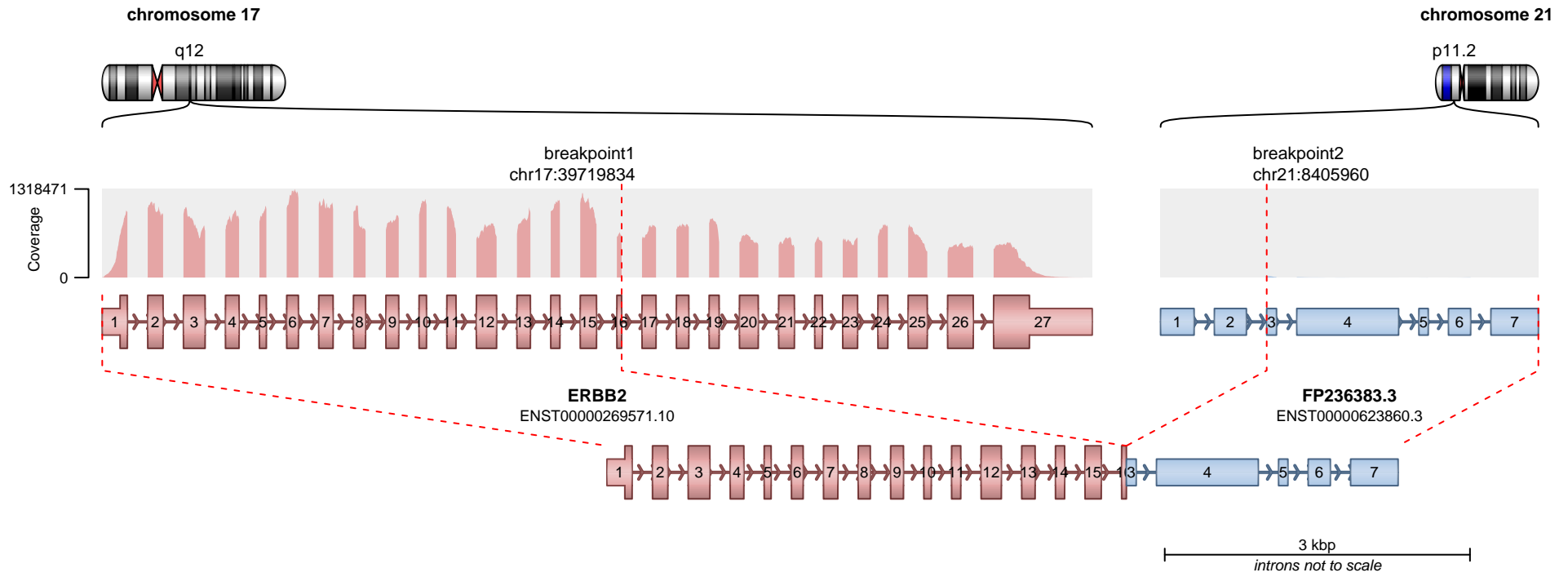

RETAINED PROTEIN DOMAINS
reading frame unclear

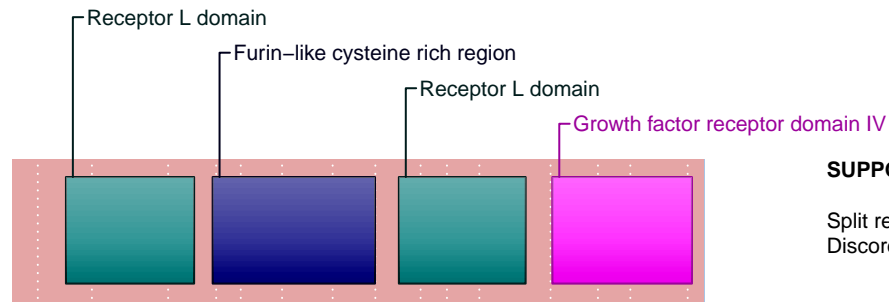

SUPPORTING READ COUNT

Split reads = 14
Discordant mates = 0

- translocation
- duplication
- deletion
- inversion

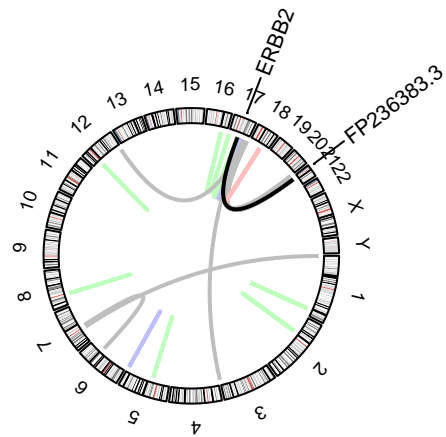
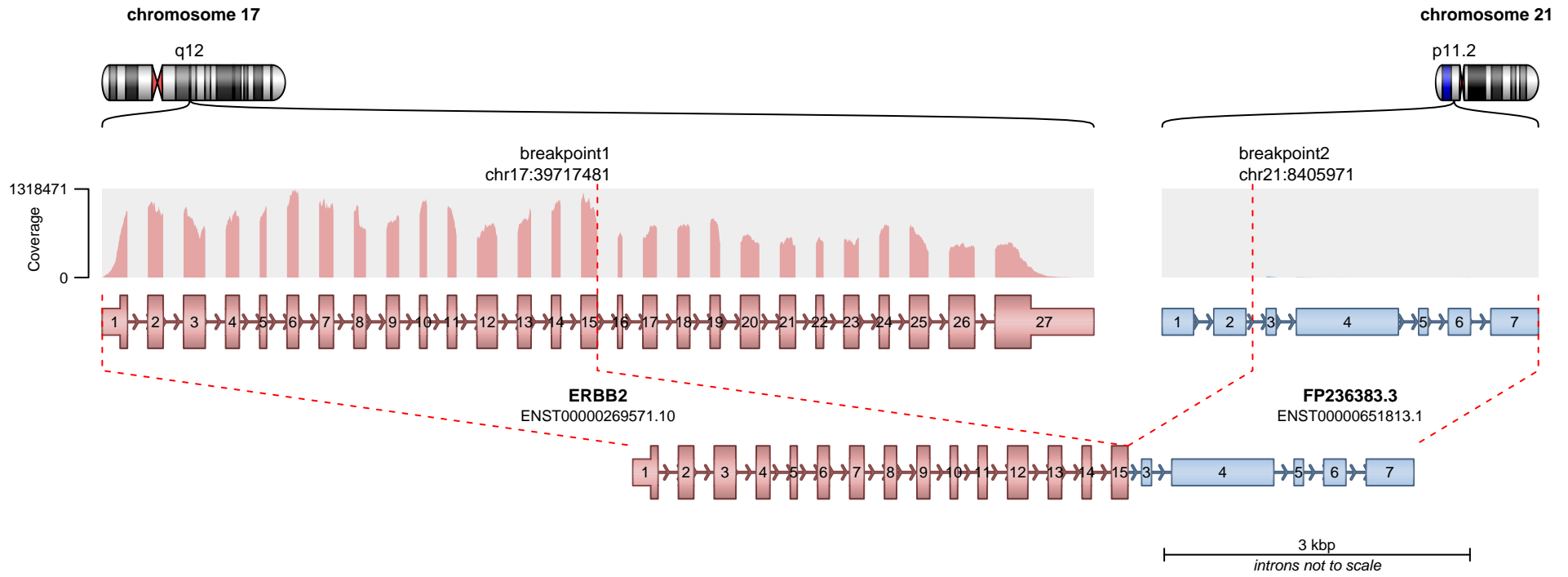

RETAINED PROTEIN DOMAINS
reading frame unclear

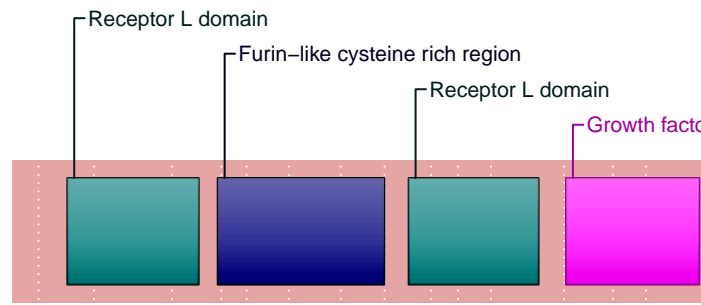

ERBB2

SUPPORTING READ COUNT

Split reads = 6
Discordant mates = 0

- translocation
- duplication
- deletion
- inversion

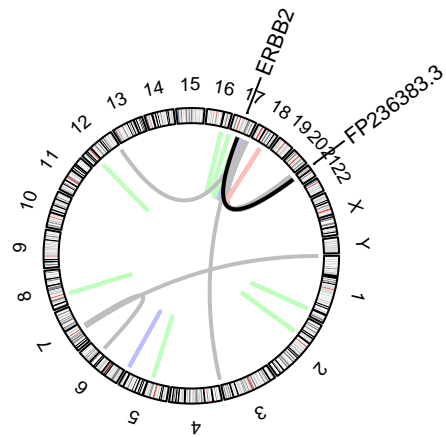
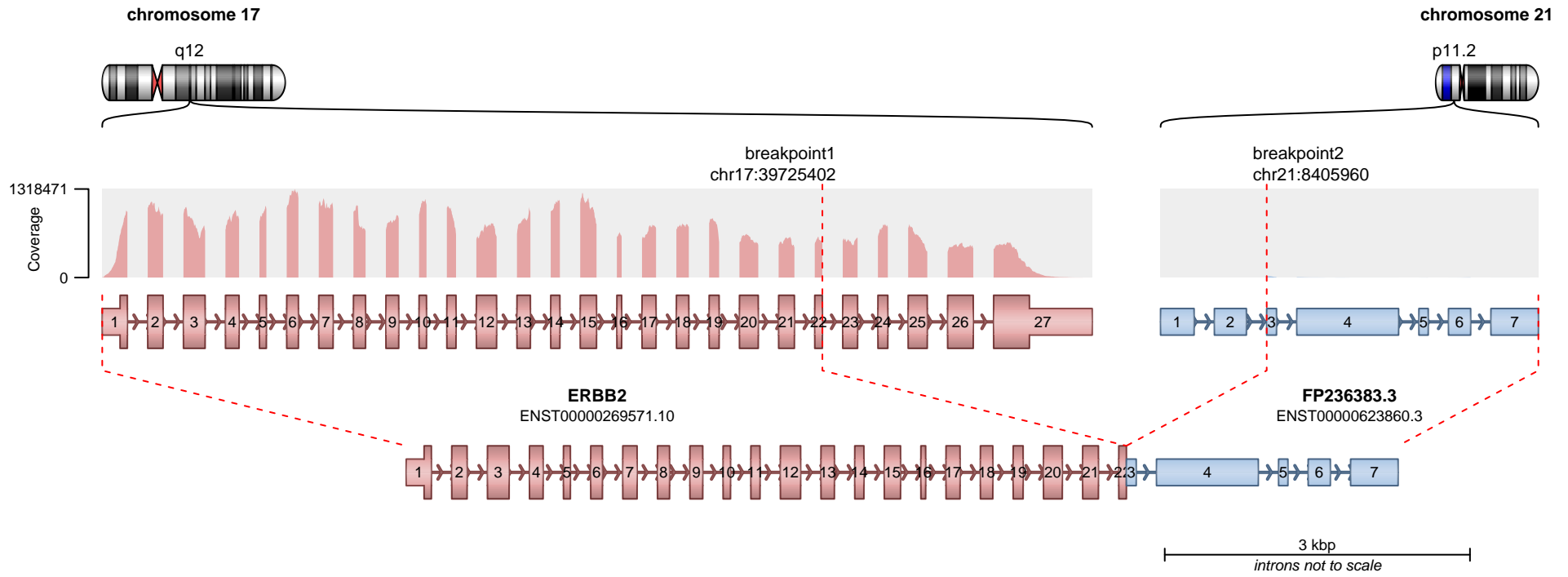

RETAINED PROTEIN DOMAINS
reading frame unclear

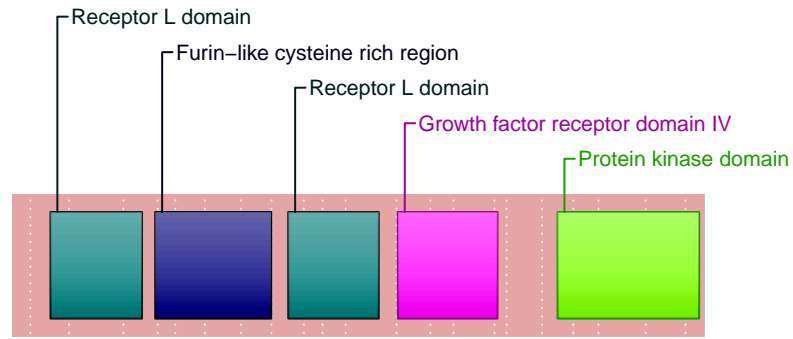

ERBB2

SUPPORTING READ COUNT

Split reads = 6
Discordant mates = 0

— translocation — deletion
— duplication — inversion

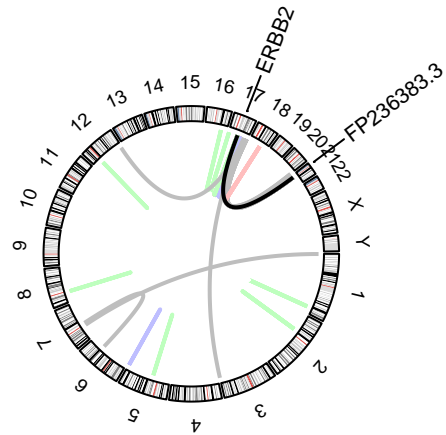
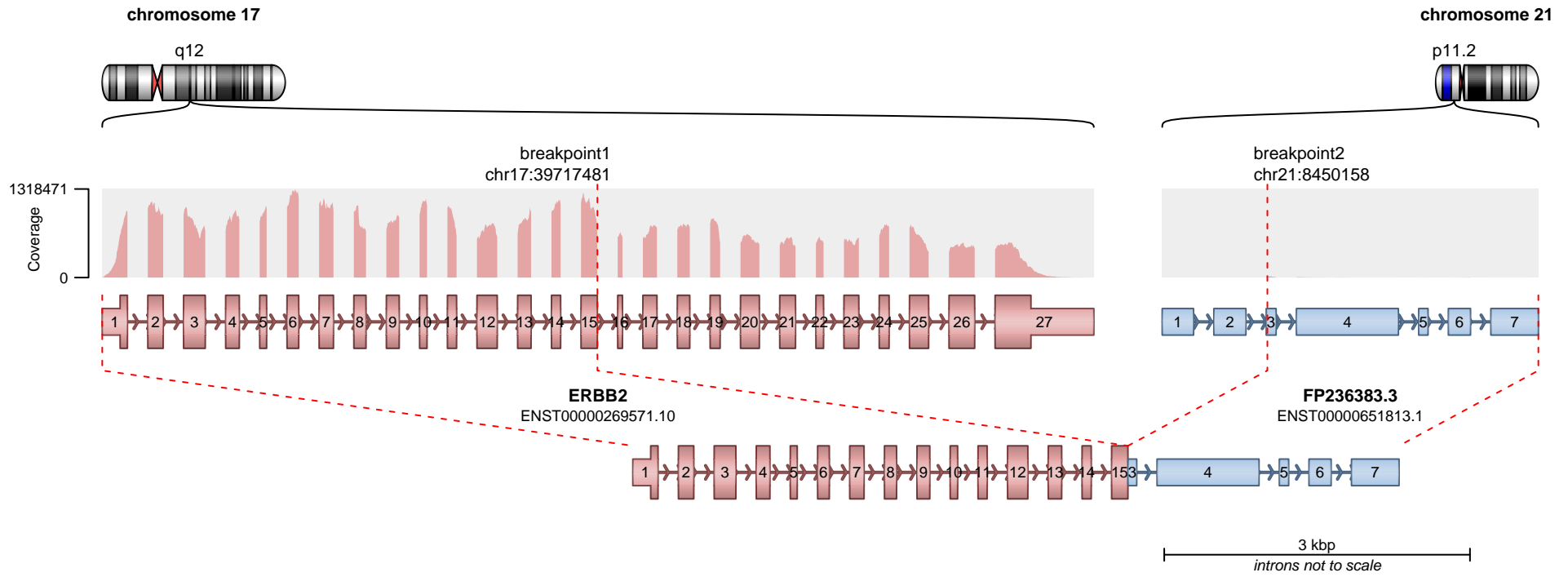

RETAINED PROTEIN DOMAINS
reading frame unclear

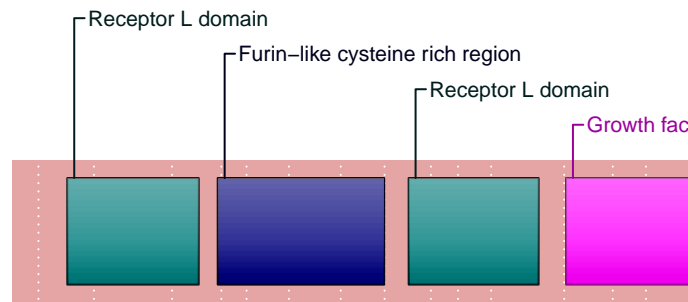

ERBB2

SUPPORTING READ COUNT

Split reads = 6
Discordant mates = 0

— translocation — deletion
— duplication — inversion

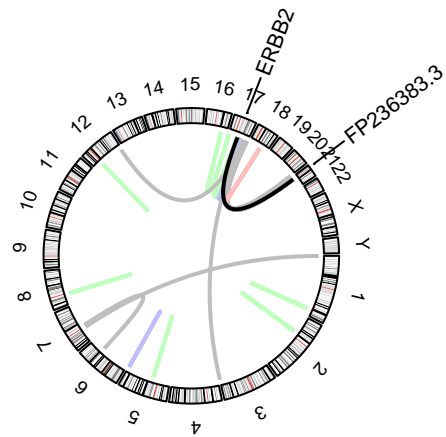
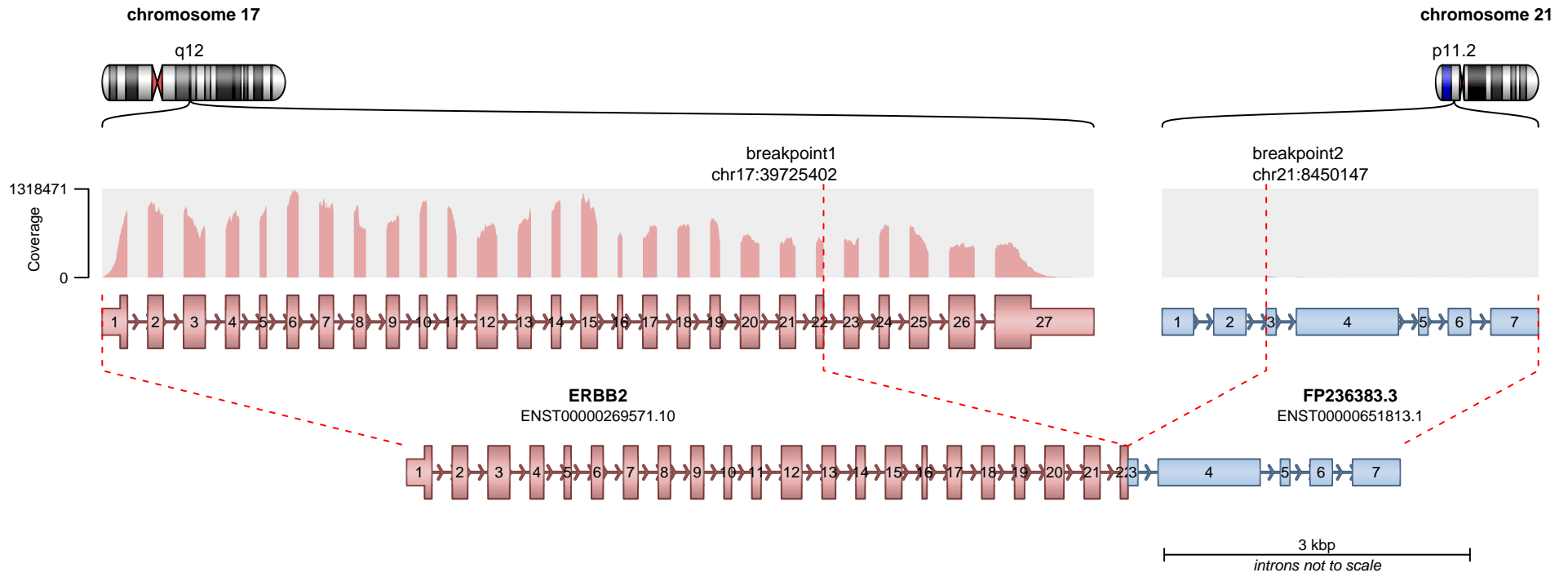

RETAINED PROTEIN DOMAINS
reading frame unclear

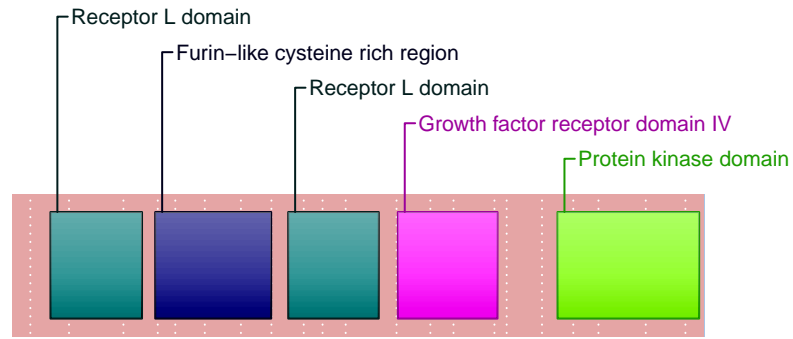

ERBB2

SUPPORTING READ COUNT

Split reads = 6
Discordant mates = 0

— translocation — deletion
— duplication — inversion

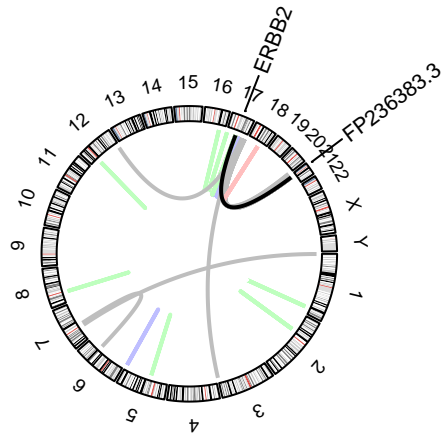
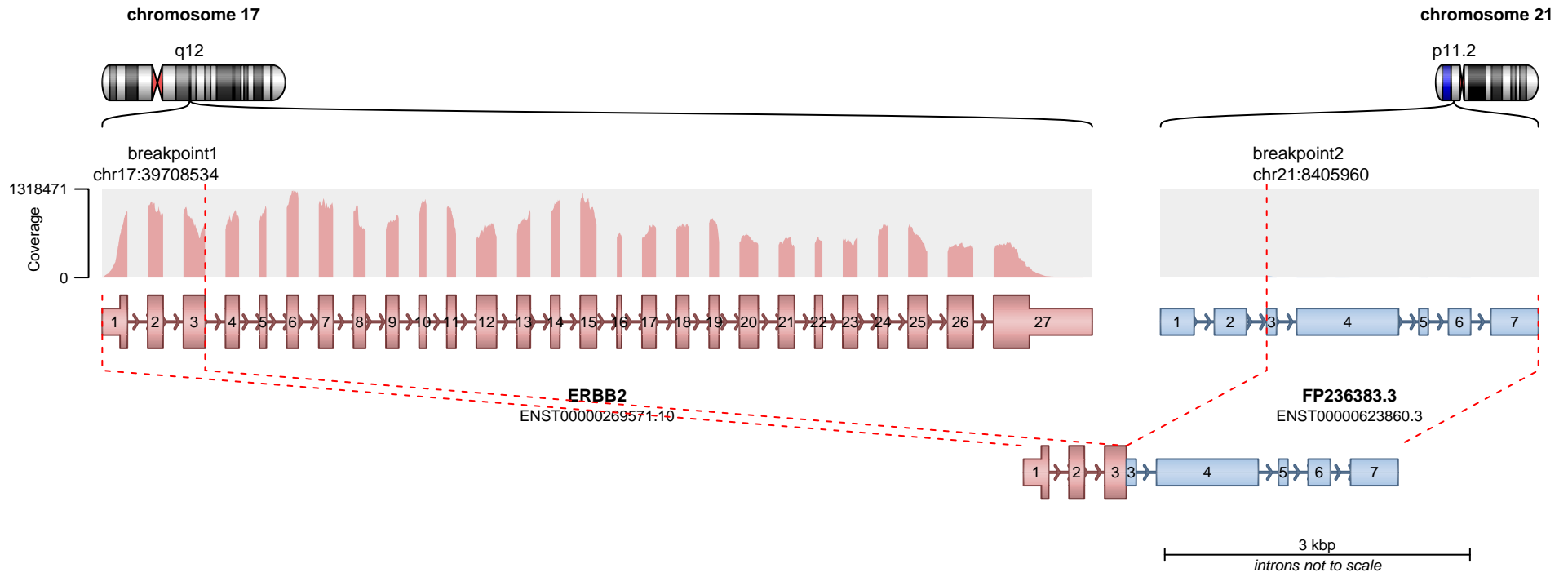

RETAINED PROTEIN DOMAINS
reading frame unclear

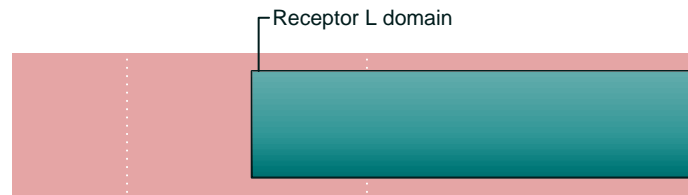

SUPPORTING READ COUNT

Split reads = 3
Discordant mates = 0

— translocation — deletion
— duplication — inversion

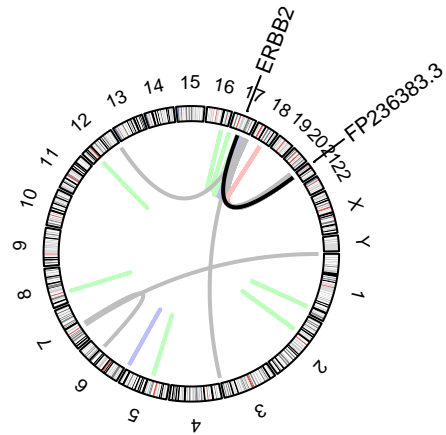
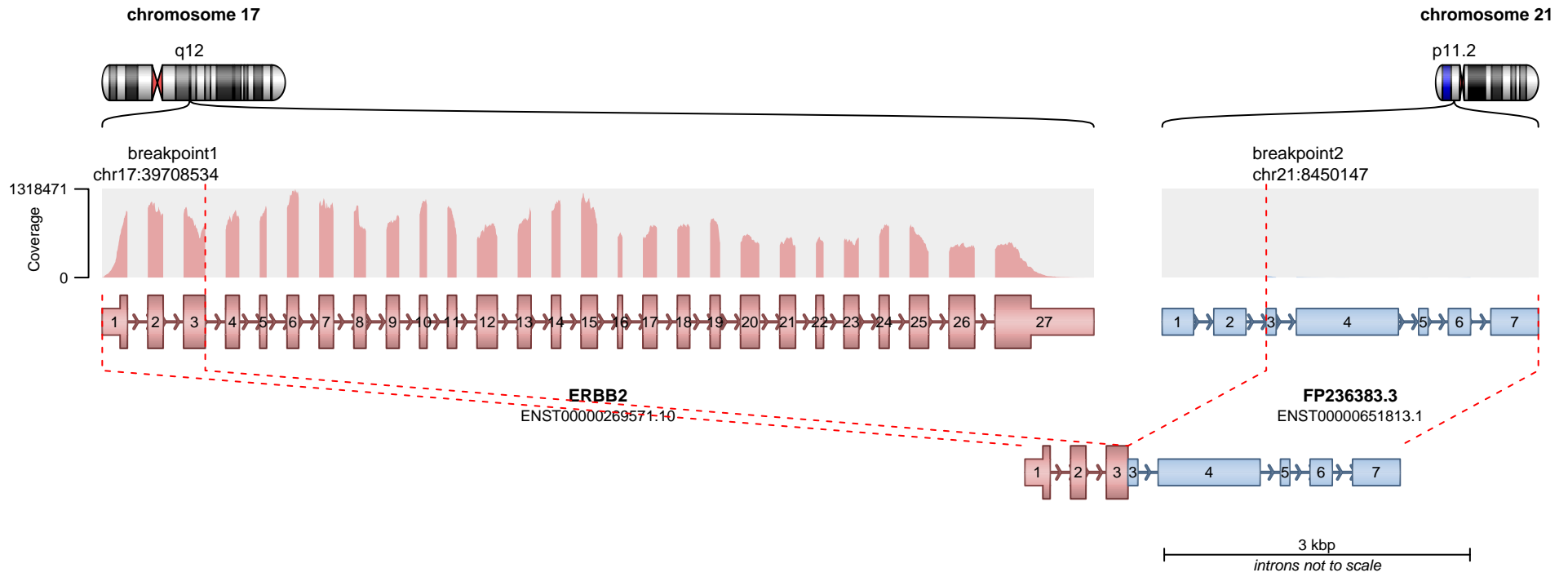

RETAINED PROTEIN DOMAINS
reading frame unclear

Receptor L domain



ERBB2

SUPPORTING READ COUNT

Split reads = 3
Discordant mates = 0

— translocation — deletion
— duplication — inversion

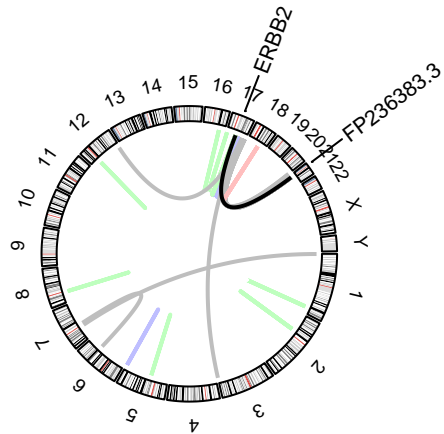
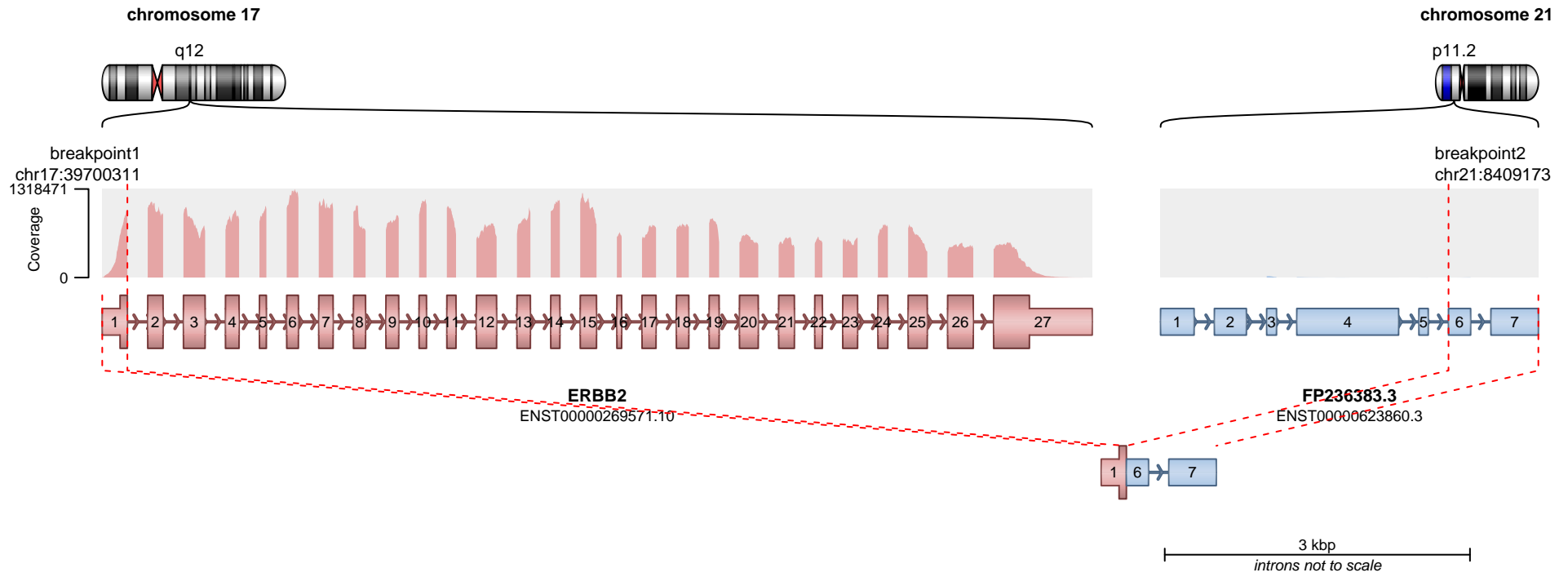

— translocation — deletion
— duplication — inversion

No protein domains retained in fusion.

SUPPORTING READ COUNT

Split reads = 2
Discordant mates = 0

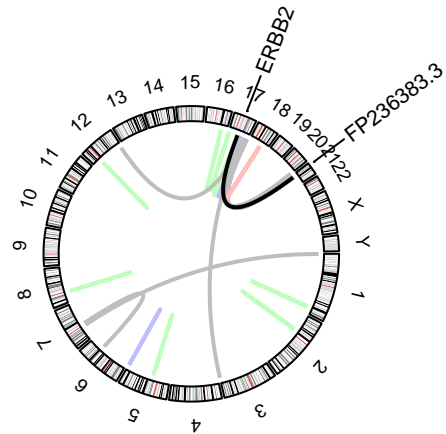
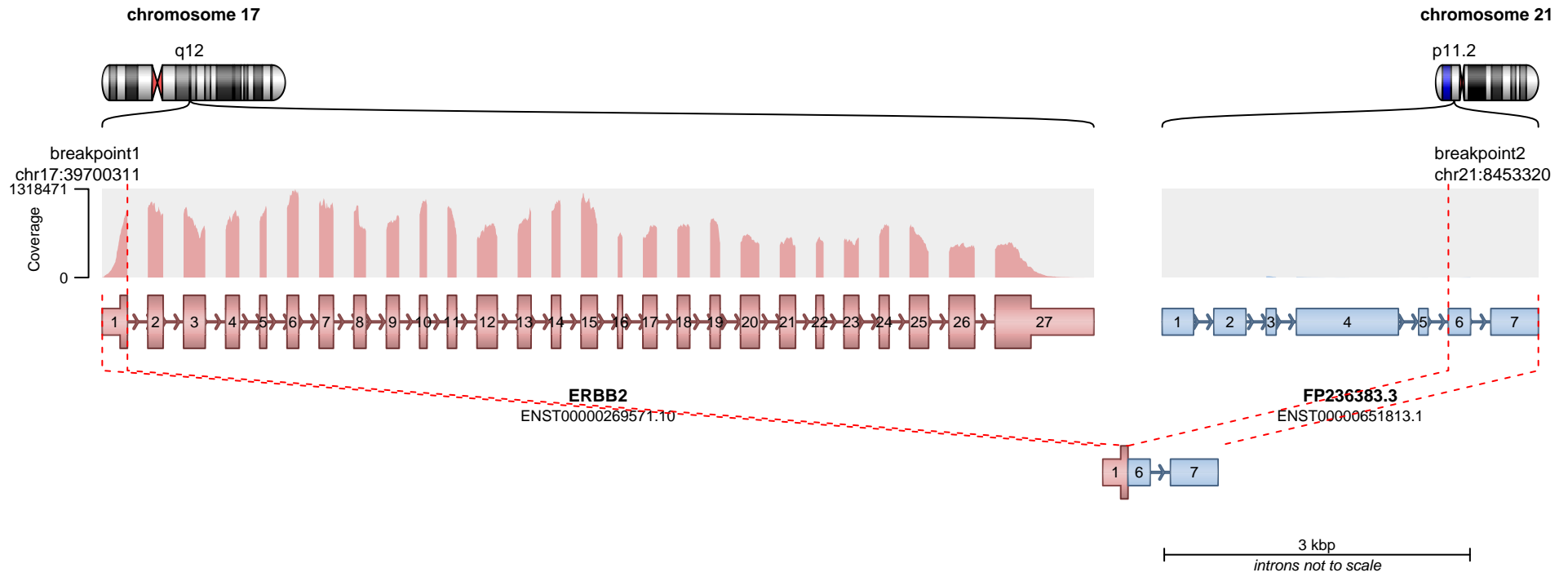

— translocation — deletion
— duplication — inversion

No protein domains retained in fusion.

SUPPORTING READ COUNT

Split reads = 2
Discordant mates = 0

chromosome 21

p11.2

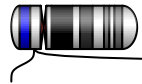

chromosome 17

q12

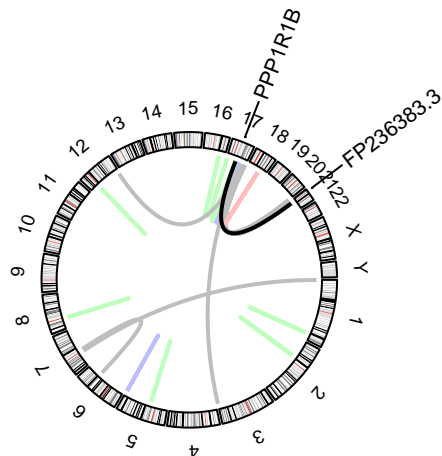
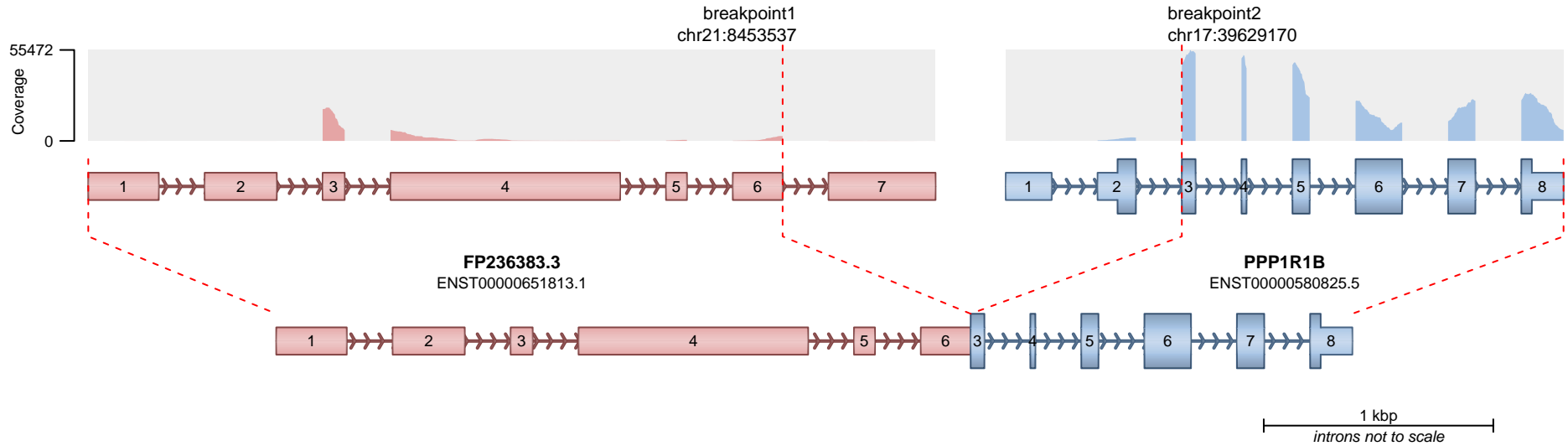
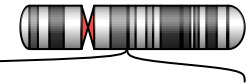

RETAINED PROTEIN DOMAINS
reading frame unclear

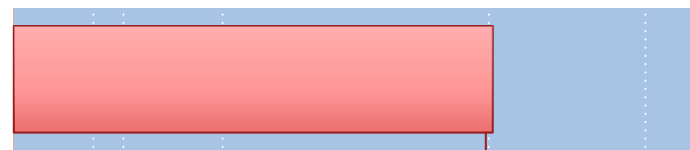

PPP1R1B

Protein phosphatase inhibitor 1/DARPP-32

SUPPORTING READ COUNT

Split reads = 1579
Discordant mates = 1

— translocation — deletion
— duplication — inversion

chromosome 21

p11.2

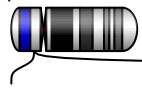

chromosome 17

q12

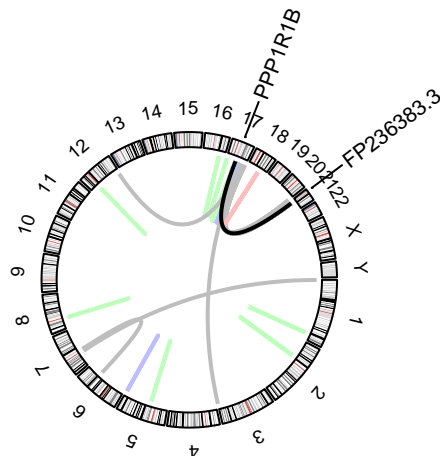
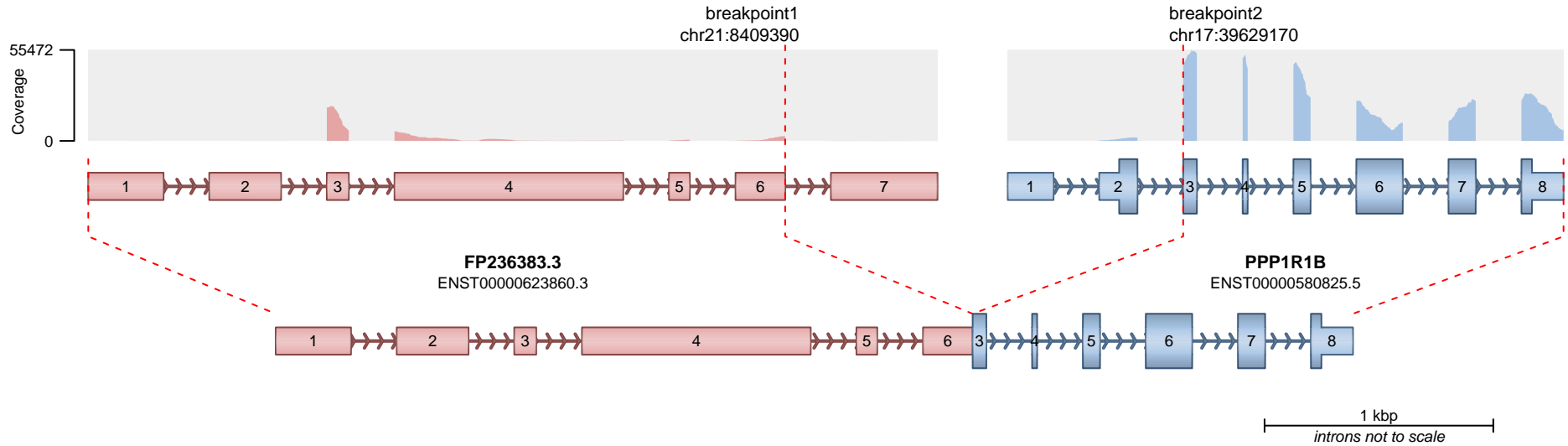
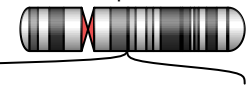

RETAINED PROTEIN DOMAINS
reading frame unclear

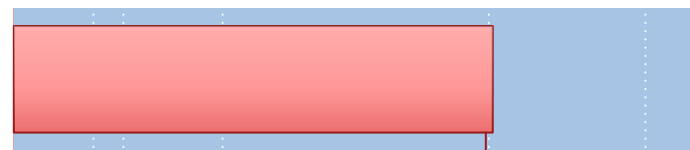

PPP1R1B

Protein phosphatase inhibitor 1/DARPP-32

SUPPORTING READ COUNT

Split reads = 1578
Discordant mates = 0

— translocation — deletion
— duplication — inversion

chromosome 21

p11.2

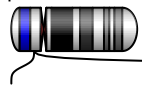

chromosome 17

q12

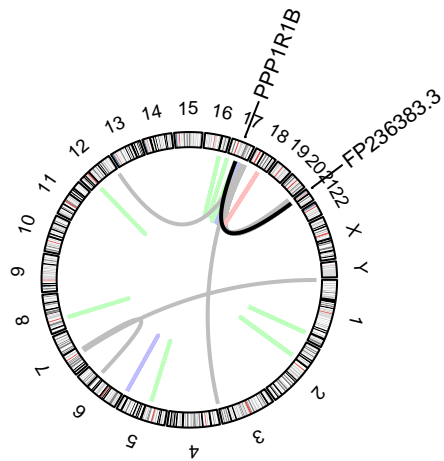
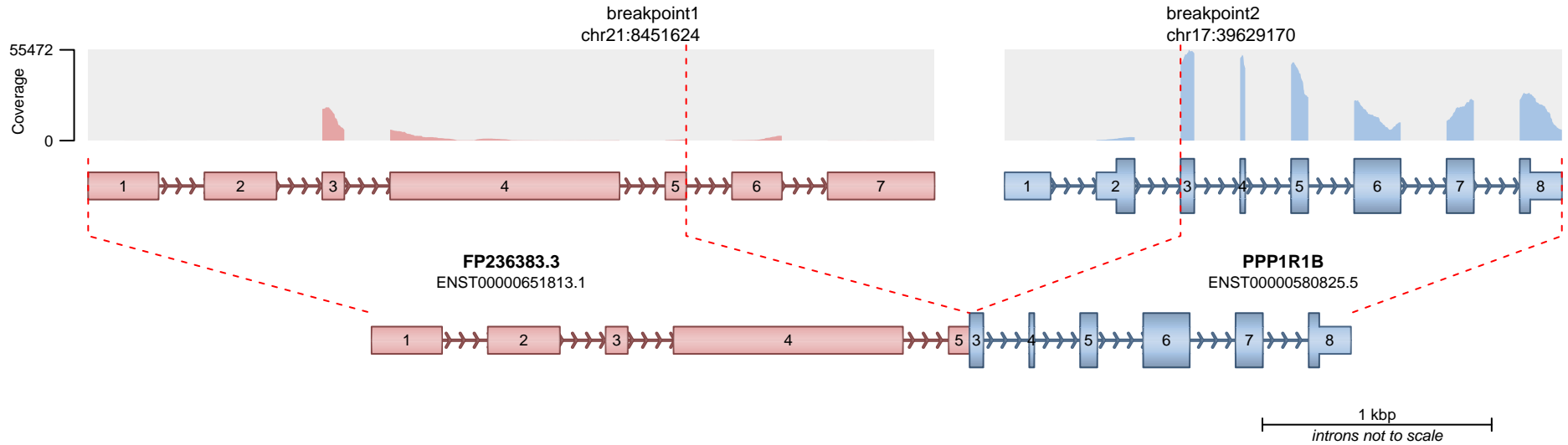
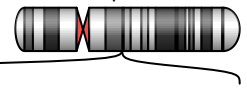

RETAINED PROTEIN DOMAINS
reading frame unclear



PPP1R1B

Protein phosphatase inhibitor 1/DARPP-32

SUPPORTING READ COUNT

Split reads = 325
Discordant mates = 0

— translocation — deletion
— duplication — inversion

chromosome 21

p11.2

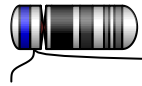

chromosome 17

q12

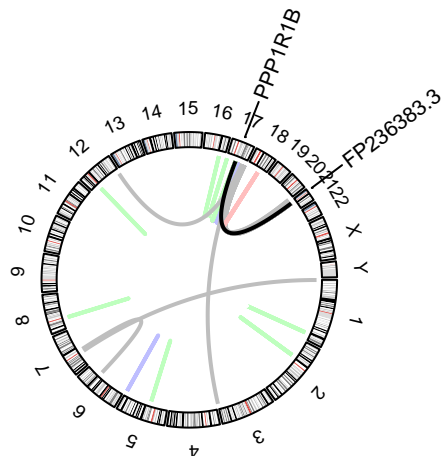
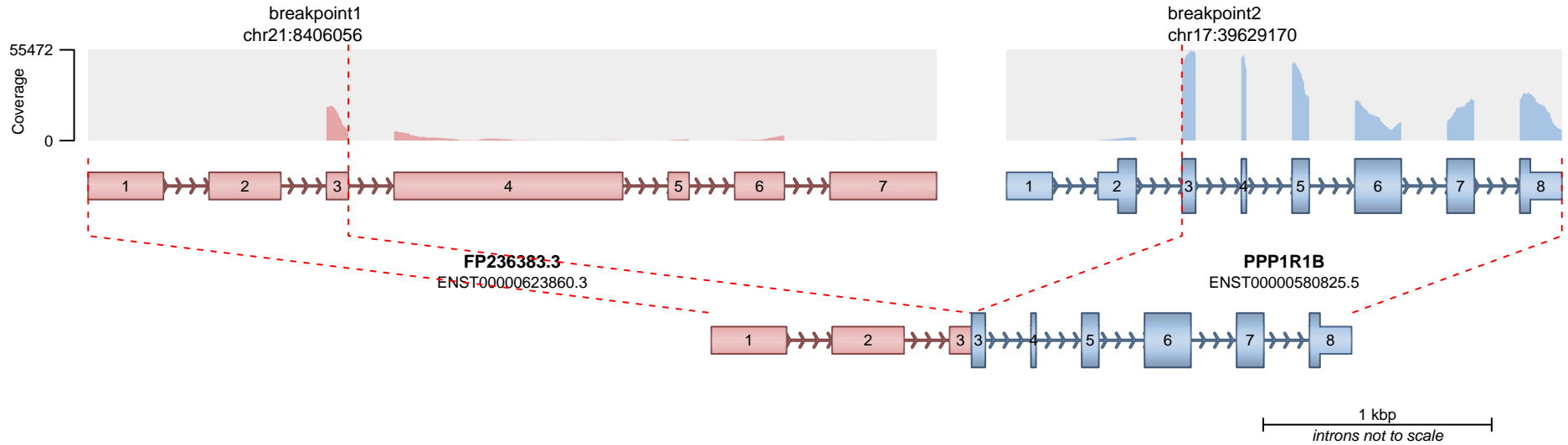
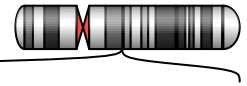

RETAINED PROTEIN DOMAINS
reading frame unclear

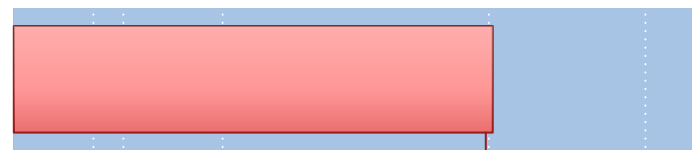

PPP1R1B

Protein phosphatase inhibitor 1/DARPP-32

SUPPORTING READ COUNT

Split reads = 23
Discordant mates = 0

— translocation — deletion
— duplication — inversion

chromosome 21

p11.2



chromosome 17

q12

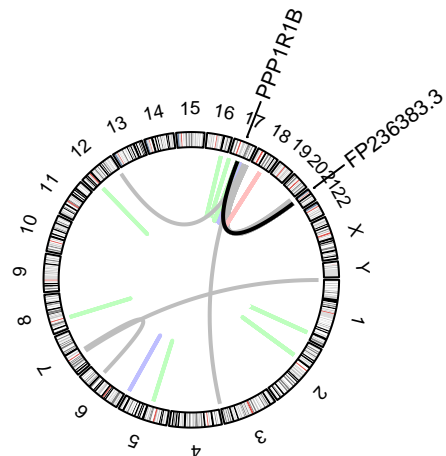
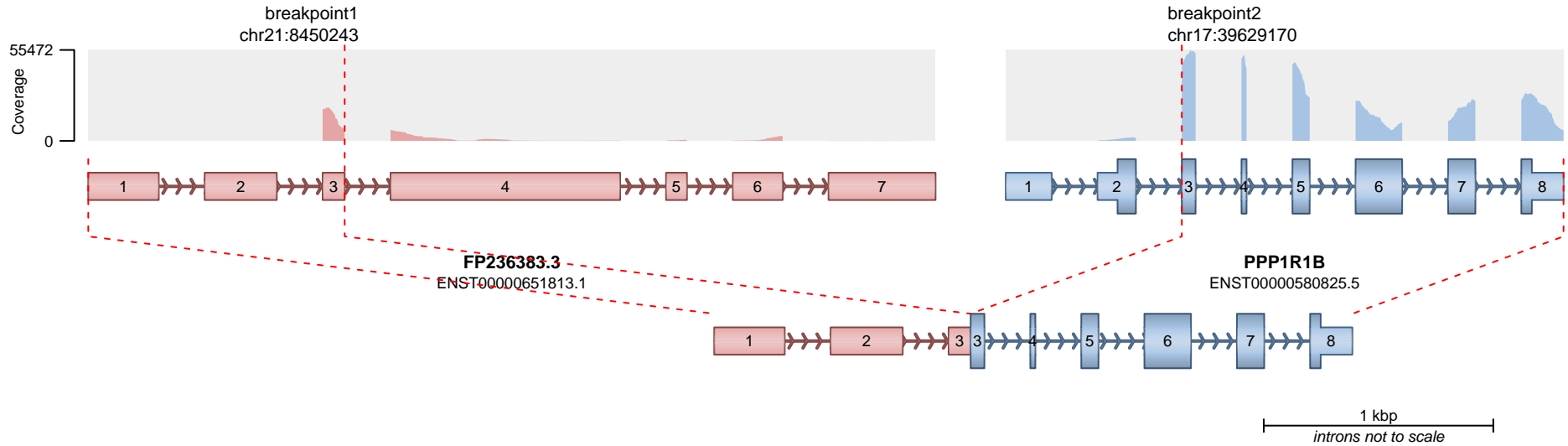
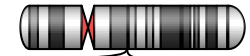

RETAINED PROTEIN DOMAINS
reading frame unclear

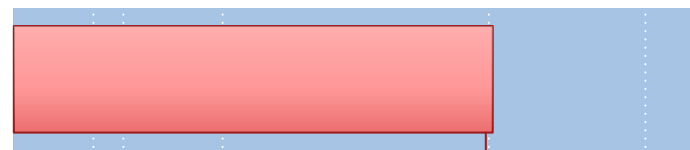

PPP1R1B

Protein phosphatase inhibitor 1/DARPP-32

SUPPORTING READ COUNT

Split reads = 23
Discordant mates = 0

— translocation — deletion
— duplication — inversion

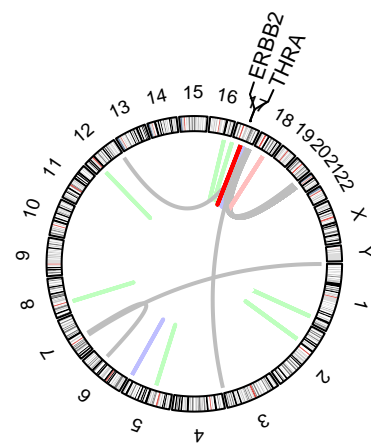
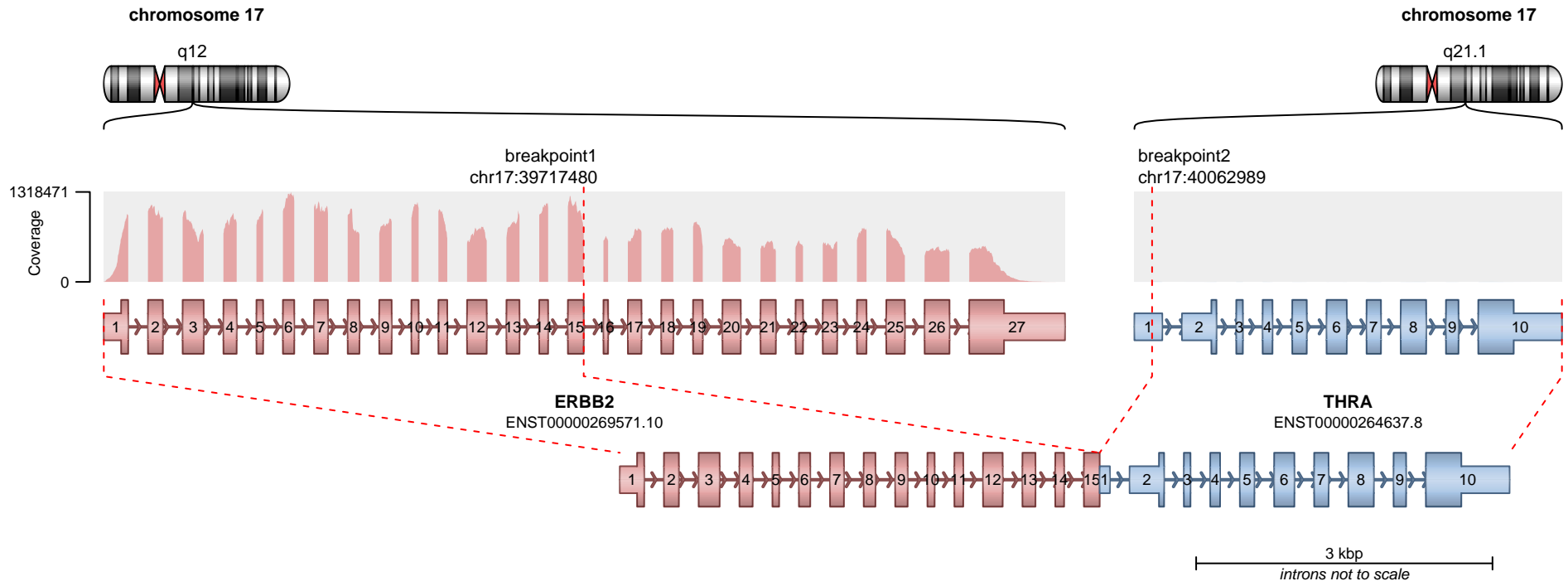

RETAINED PROTEIN DOMAINS
reading frame unclear

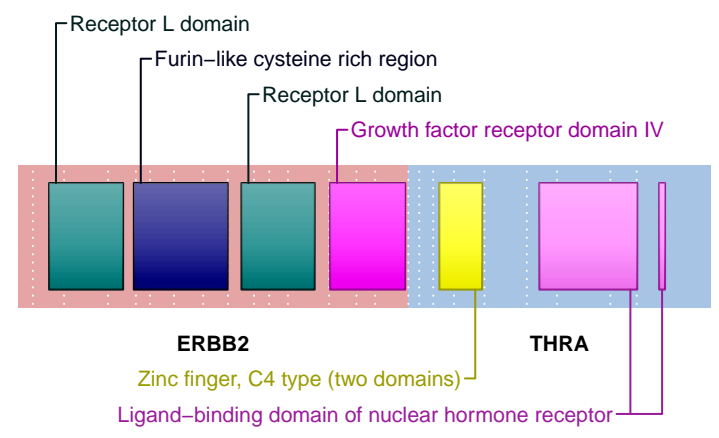

SUPPORTING READ COUNT

Split reads = 982
Discordant mates = 2

— translocation — deletion
— duplication — inversion

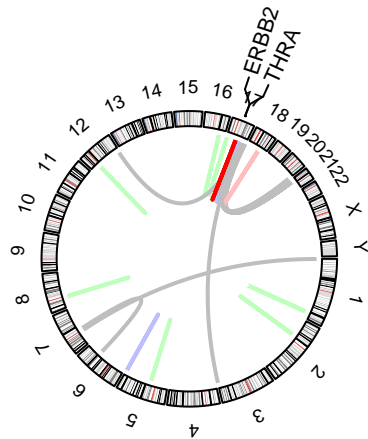
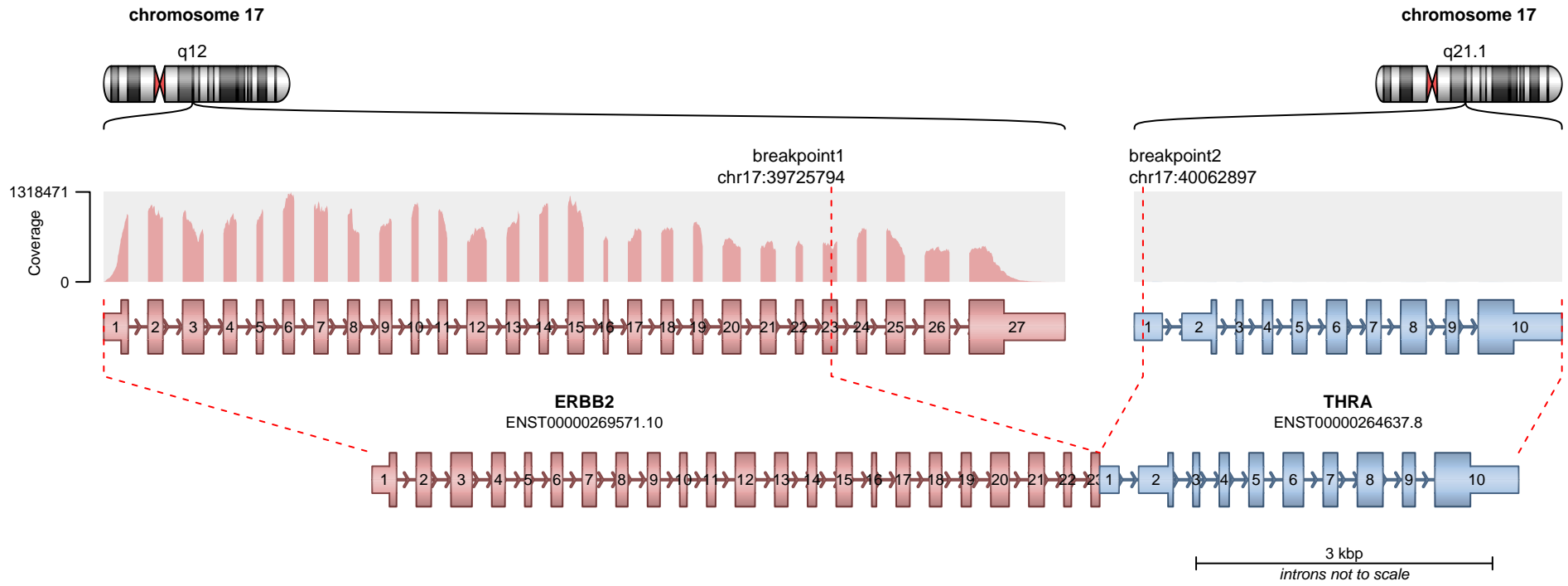

RETAINED PROTEIN DOMAINS
reading frame unclear

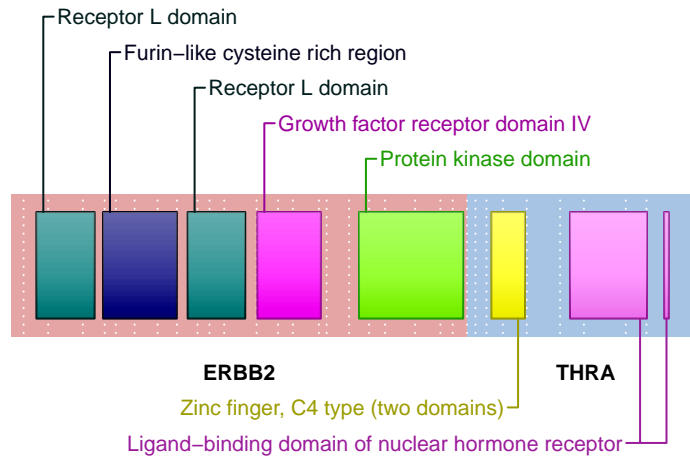

SUPPORTING READ COUNT

Split reads = 5
Discordant mates = 2

— translocation — deletion
— duplication — inversion

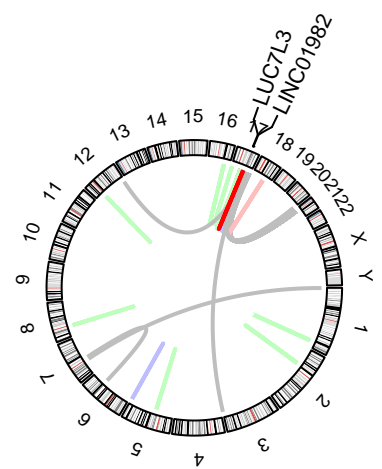
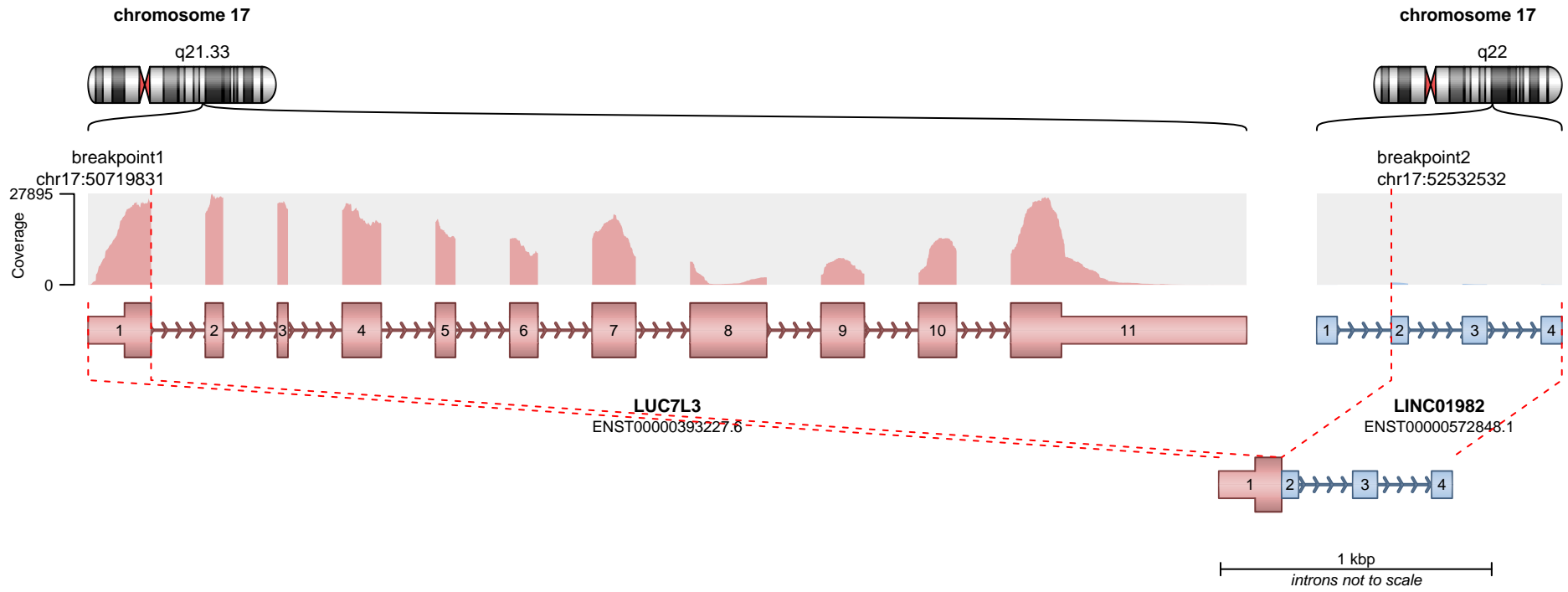

RETAINED PROTEIN DOMAINS
reading frame unclear

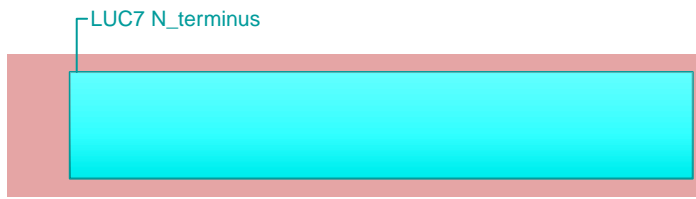

SUPPORTING READ COUNT

Split reads = 419
Discordant mates = 18

— translocation — deletion
— duplication — inversion

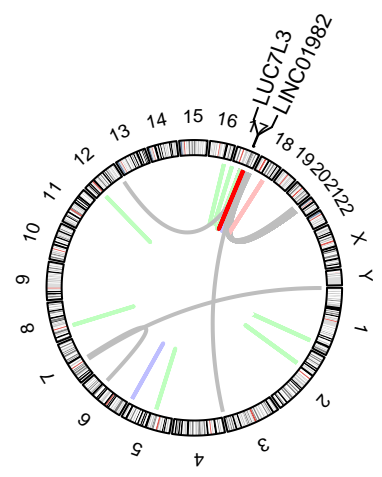
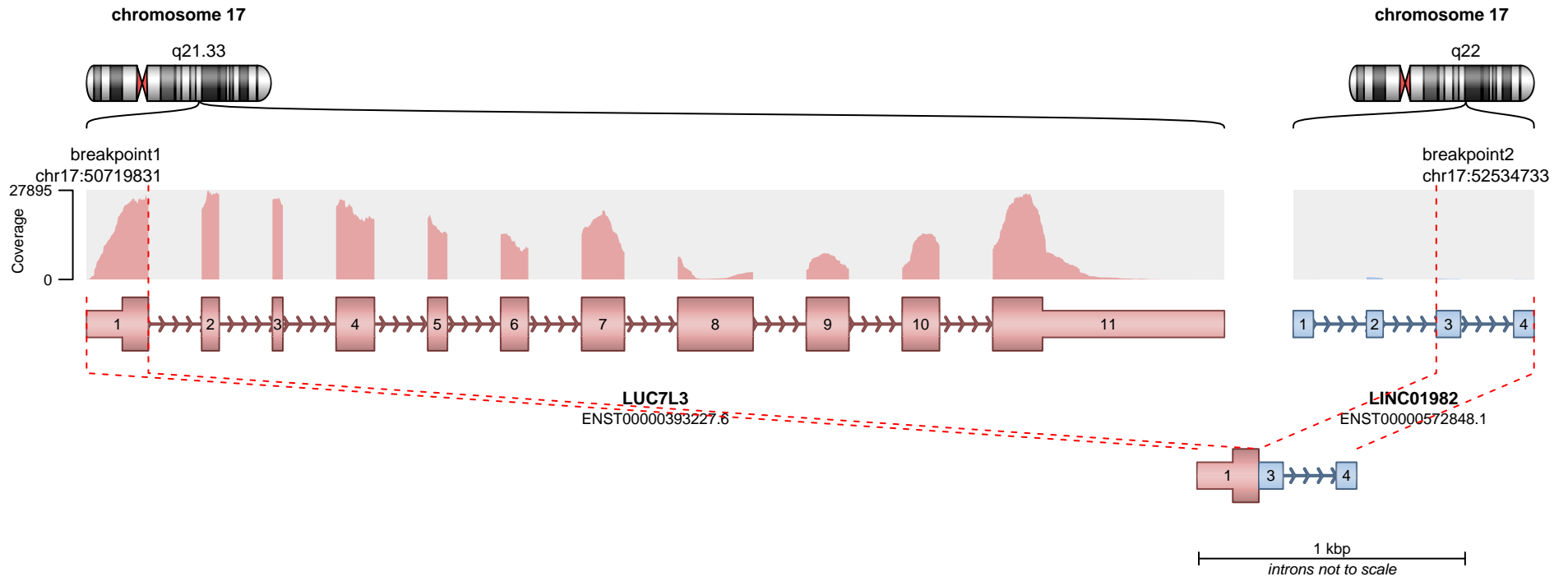

RETAINED PROTEIN DOMAINS
reading frame unclear

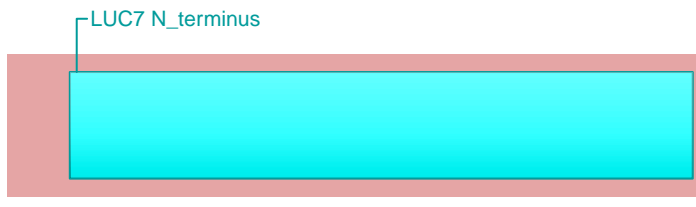

SUPPORTING READ COUNT

Split reads = 33
Discordant mates = 4

- translocation
- duplication
- deletion
- inversion

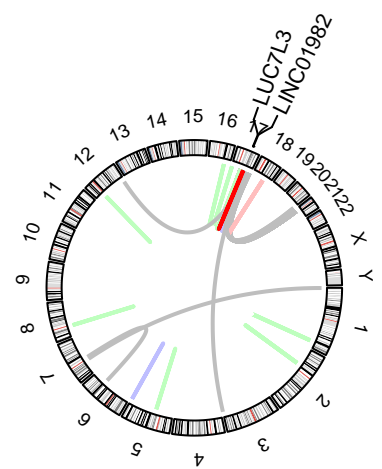
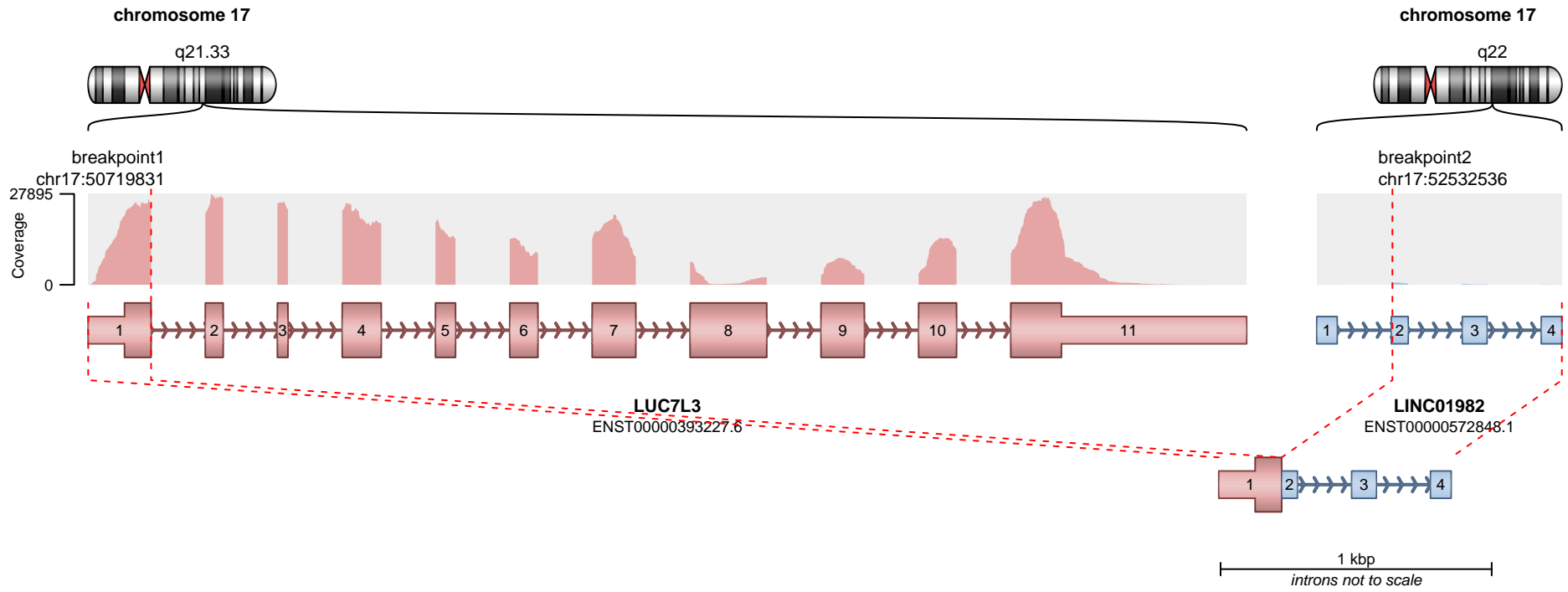

RETAINED PROTEIN DOMAINS
reading frame unclear

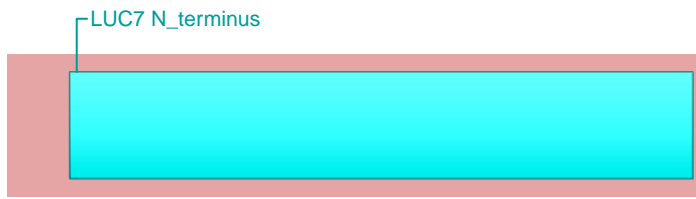

LUC7L3

SUPPORTING READ COUNT

Split reads = 9
Discordant mates = 18

— translocation — deletion
— duplication — inversion

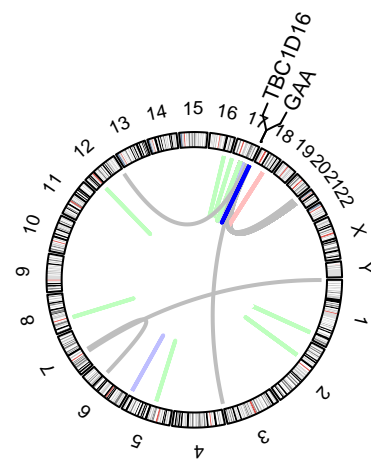
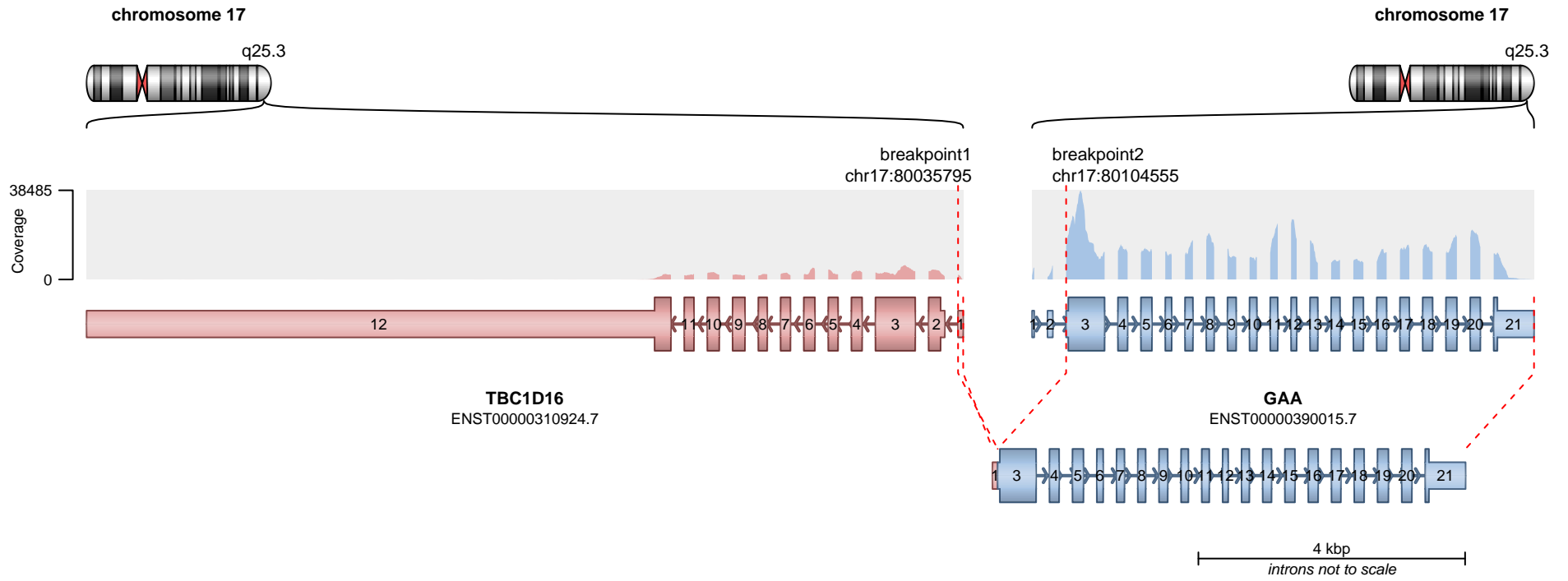

RETAINED PROTEIN DOMAINS
reading frame unclear

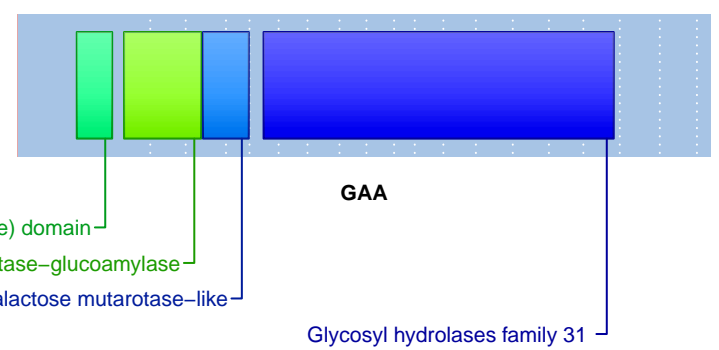

SUPPORTING READ COUNT

Split reads = 417
Discordant mates = 0

- translocation
- duplication
- deletion
- inversion

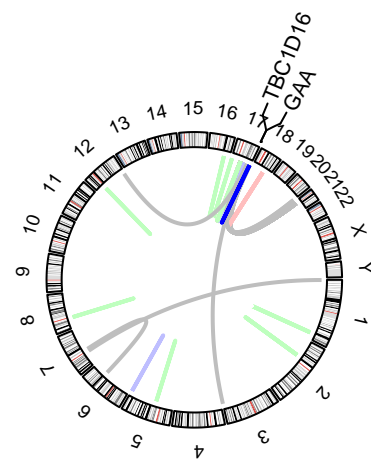
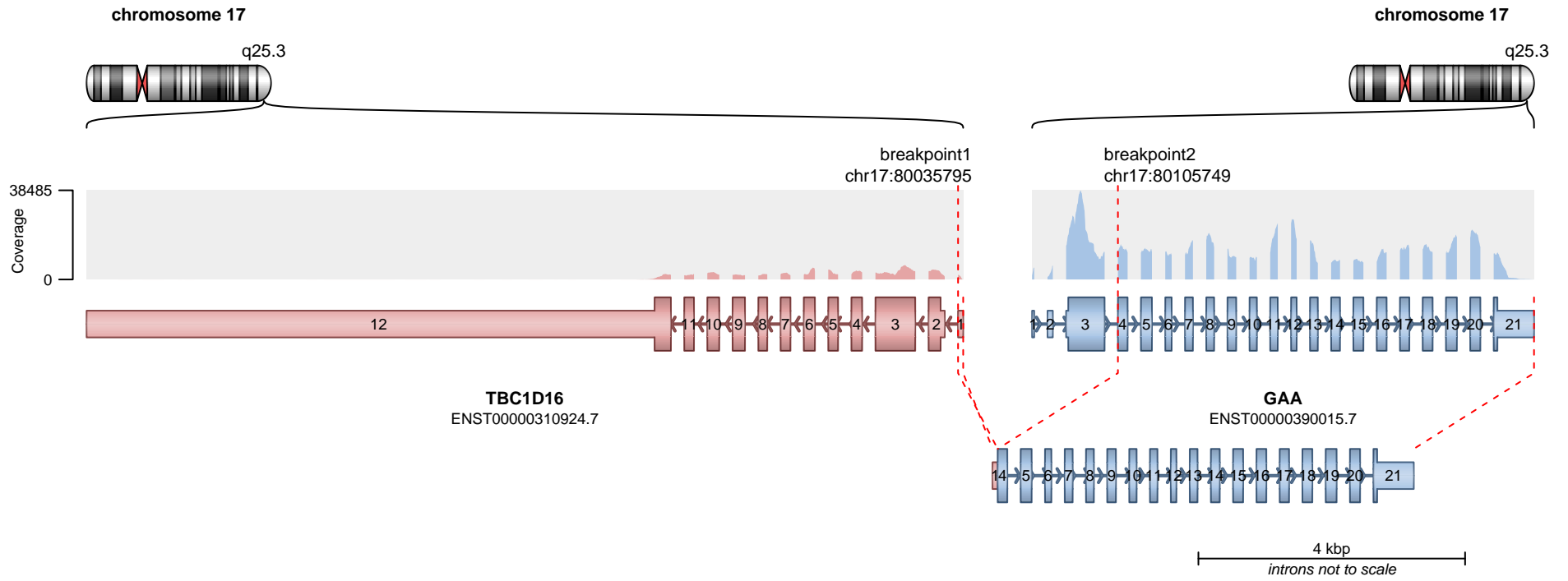

— translocation — deletion
 — duplication — inversion

RETAINED PROTEIN DOMAINS
 reading frame unclear

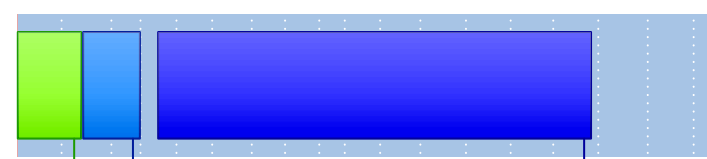

SUPPORTING READ COUNT

Split reads = 13
 Discordant mates = 0

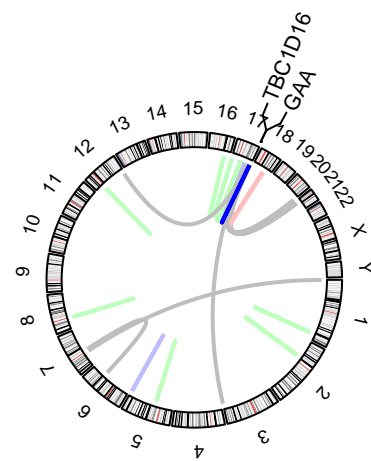
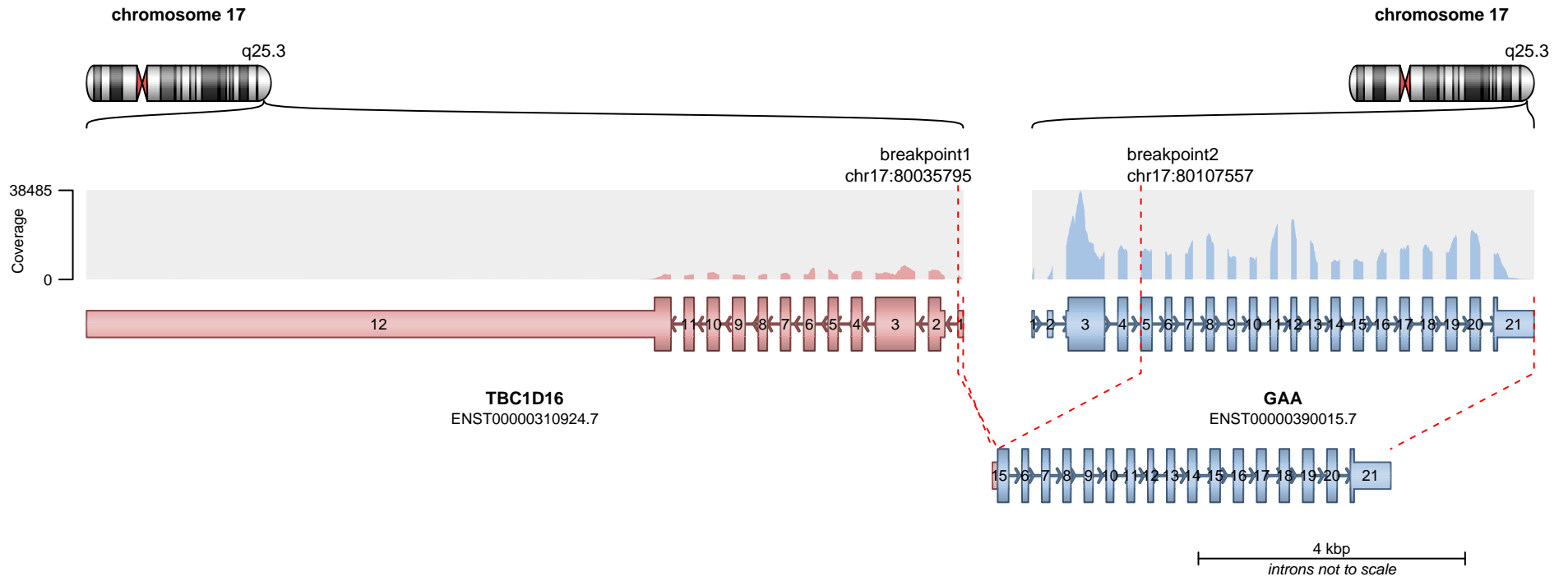

N-terminal barrel of NtMGAM and CtMGAM, maltase-glucoamylase

Galactose mutarotase-like

RETAINED PROTEIN DOMAINS
reading frame unclear

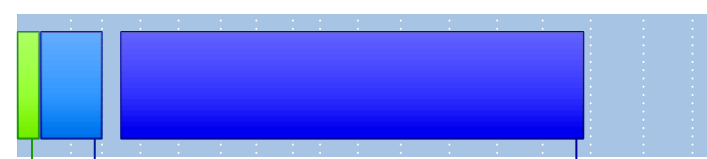

Glycosyl hydrolases family 31

SUPPORTING READ COUNT

Split reads = 1
Discordant mates = 0

— translocation — deletion
— duplication — inversion

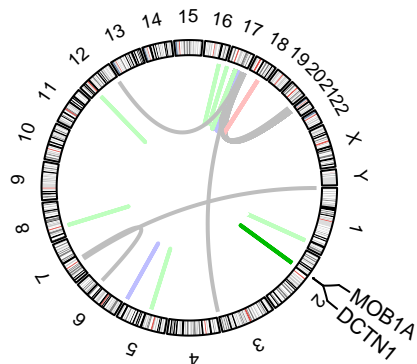
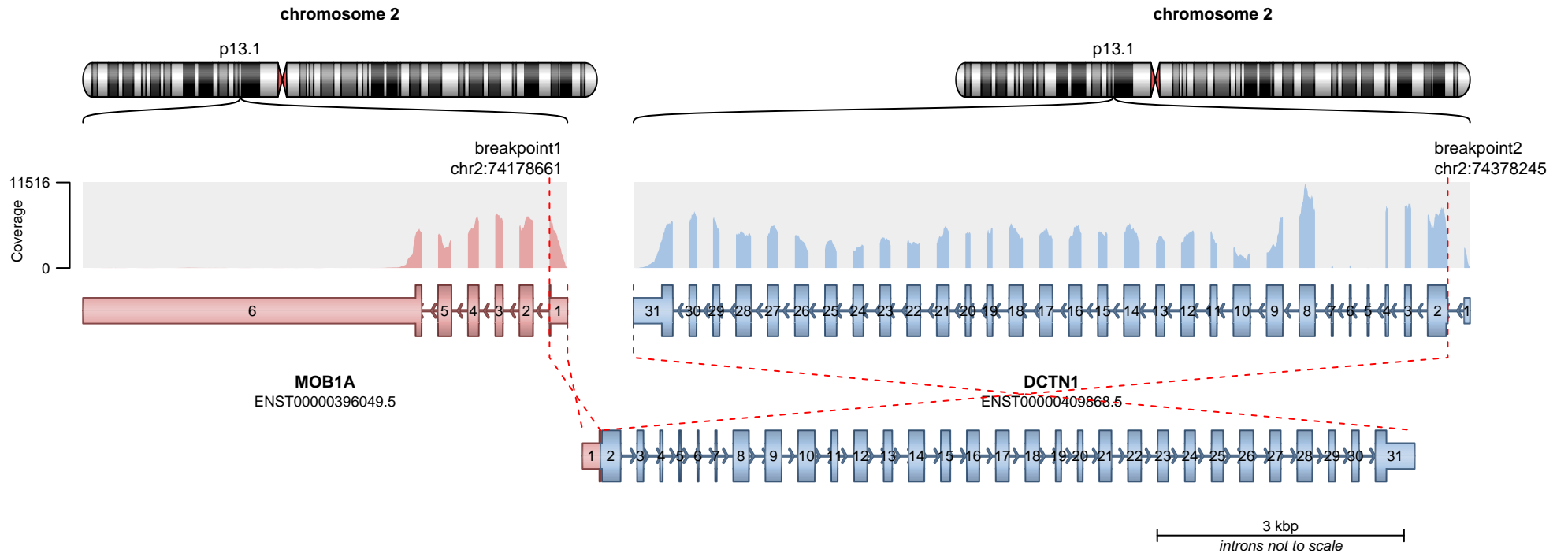

RETAINED PROTEIN DOMAINS
reading frame unclear

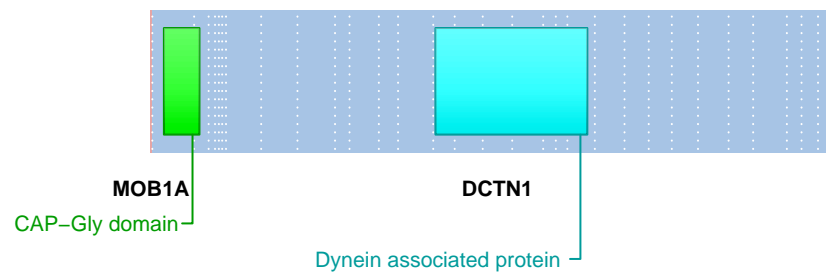

SUPPORTING READ COUNT

Split reads = 400
Discordant mates = 18

- translocation
- duplication
- deletion
- inversion

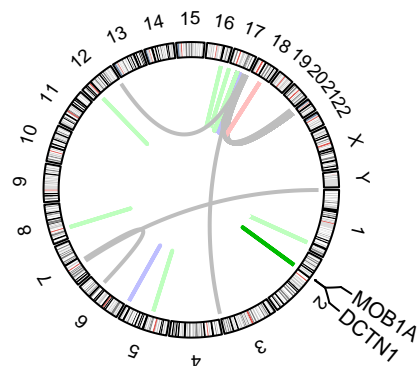
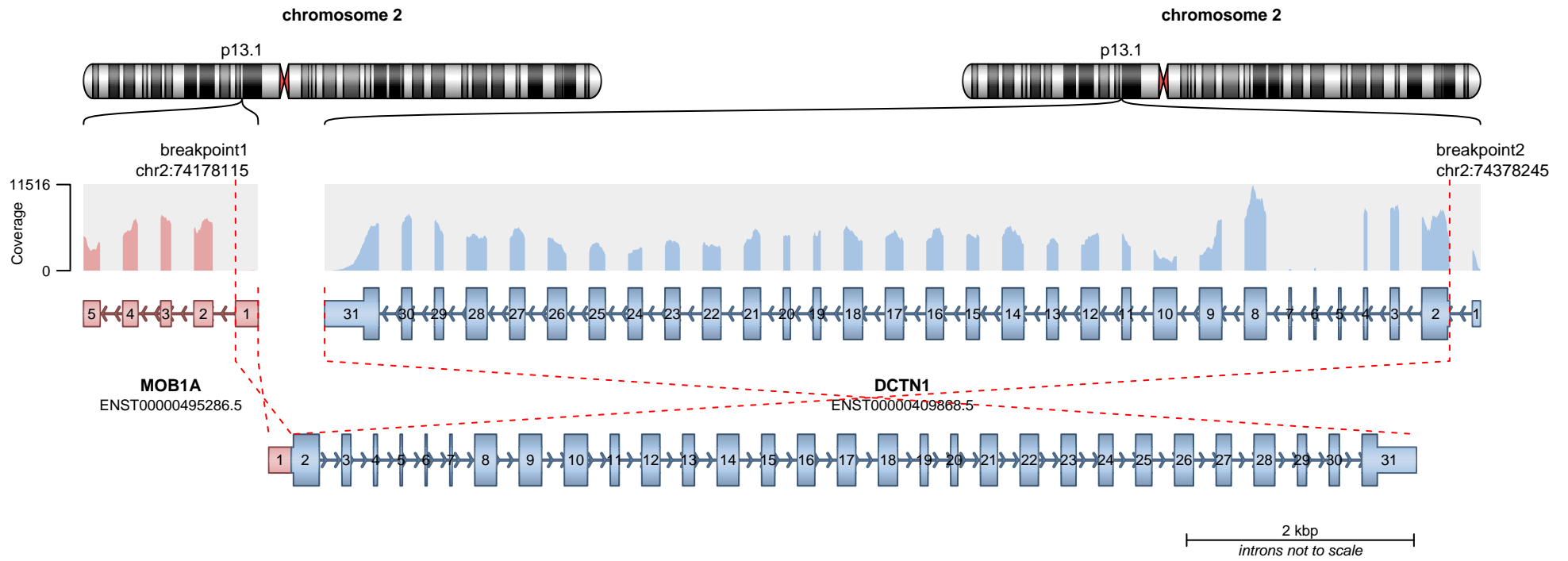

RETAINED PROTEIN DOMAINS
reading frame unclear

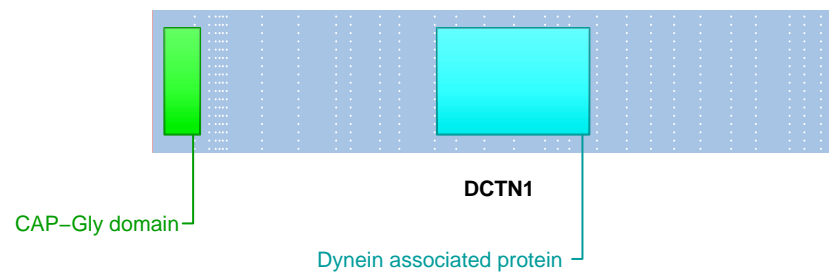

SUPPORTING READ COUNT

Split reads = 1
Discordant mates = 18

— translocation — deletion
— duplication — inversion

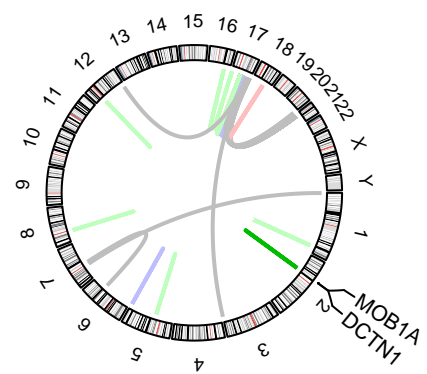
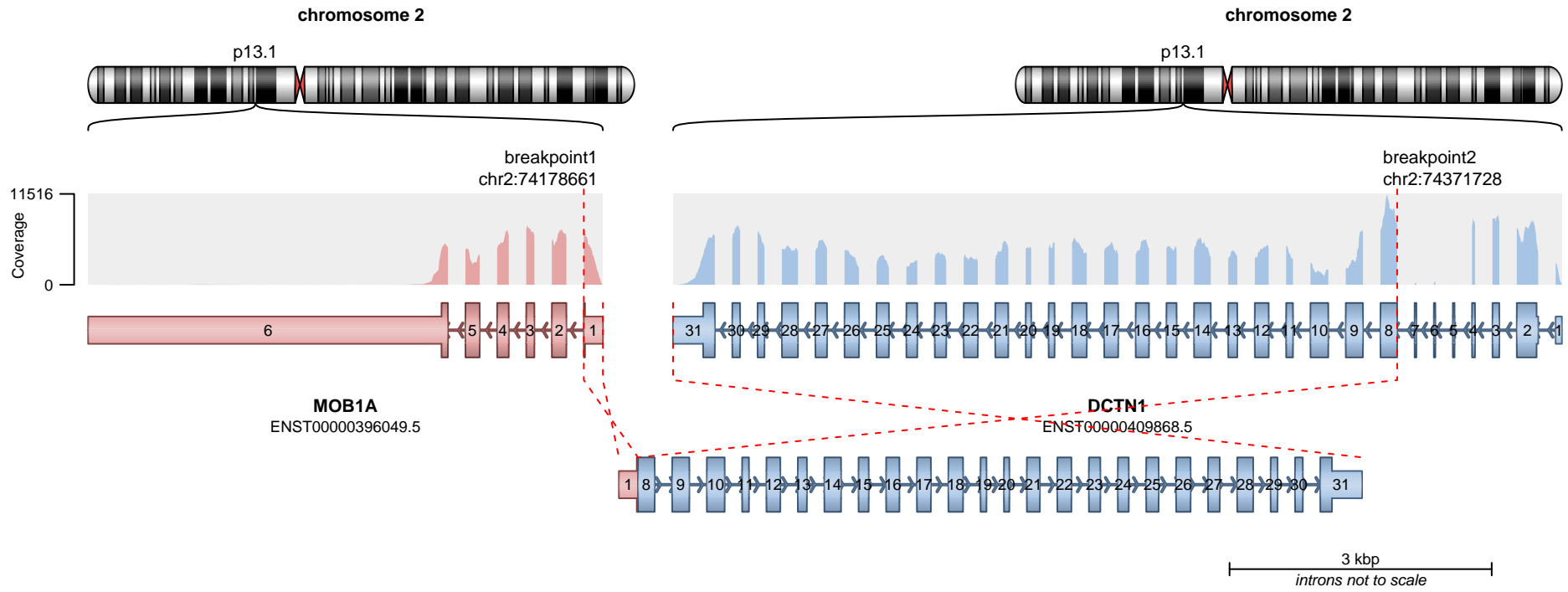

RETAINED PROTEIN DOMAINS
reading frame unclear

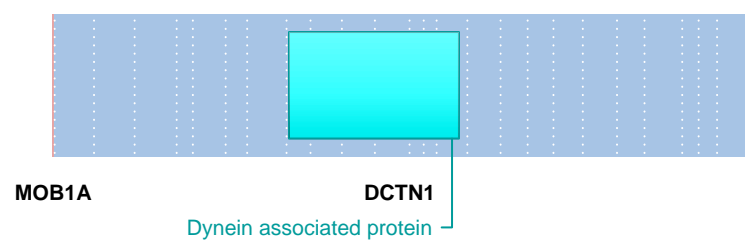

SUPPORTING READ COUNT

Split reads = 2
Discordant mates = 0

- translocation
- duplication
- deletion
- inversion

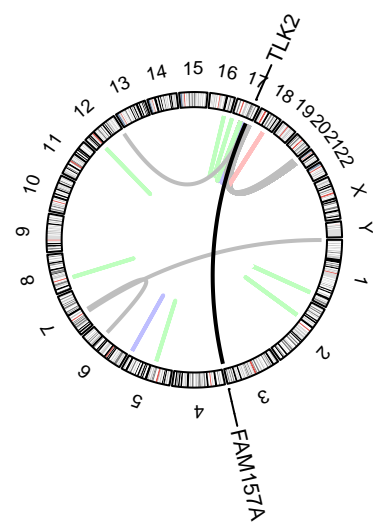
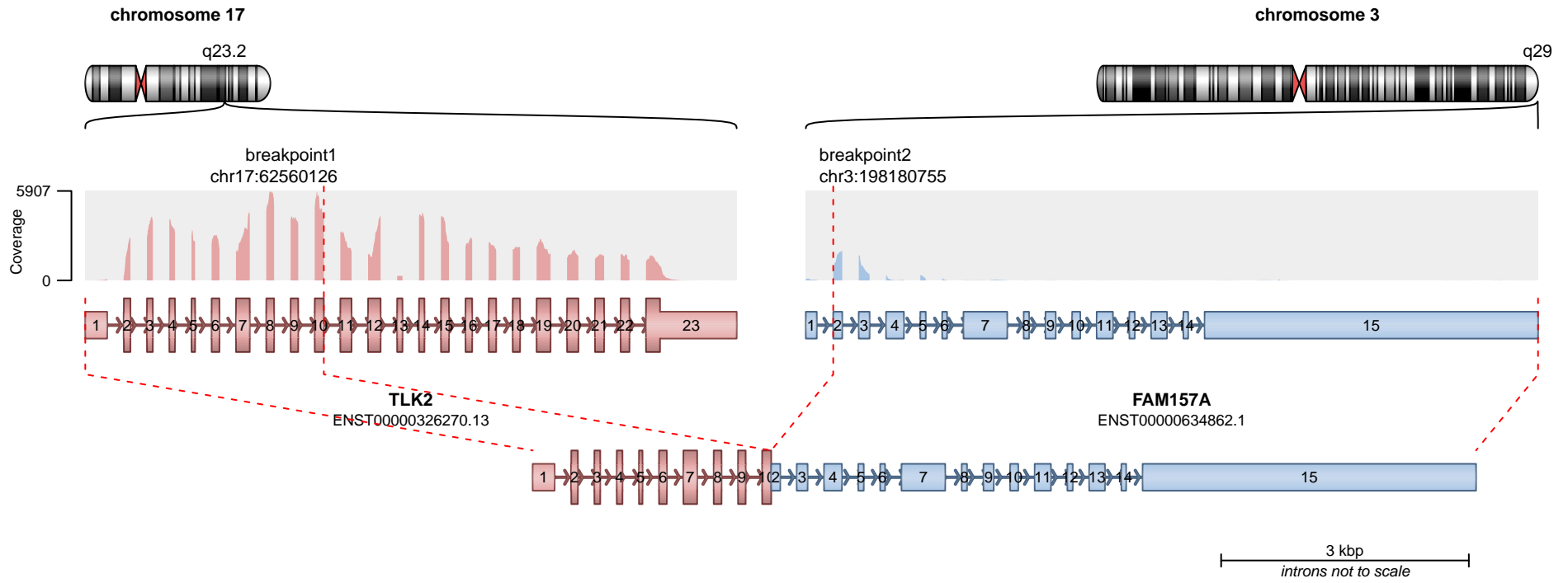

— translocation — deletion
— duplication — inversion

No protein domains retained in fusion.

SUPPORTING READ COUNT

Split reads = 165
Discordant mates = 3

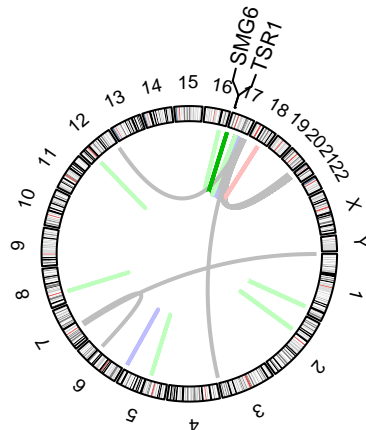
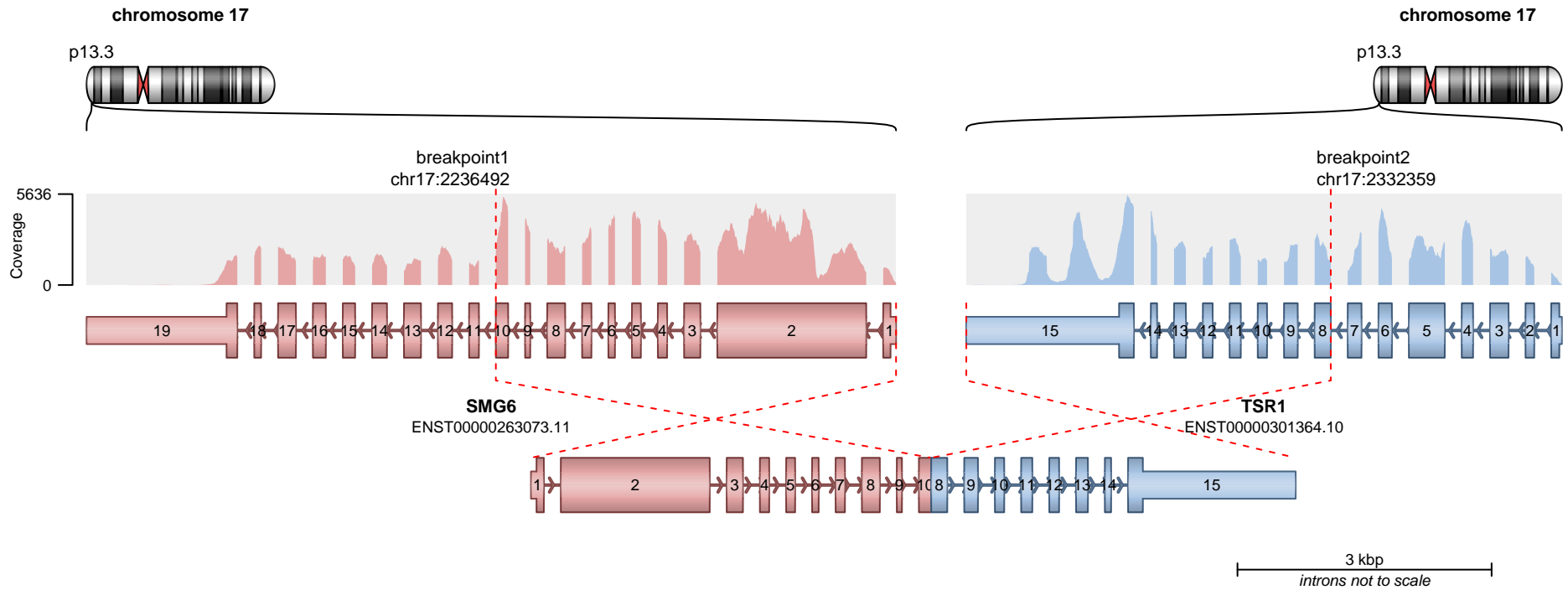

RETAINED PROTEIN DOMAINS
reading frame unclear

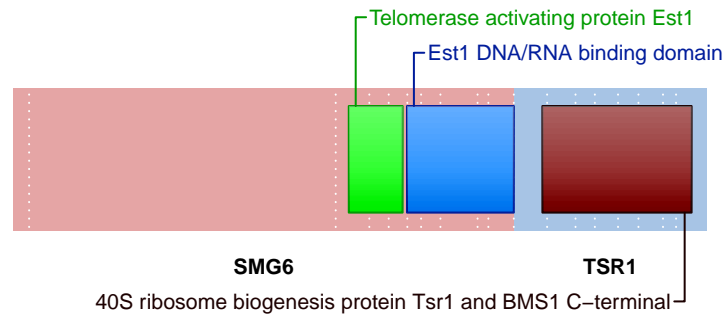

SUPPORTING READ COUNT

Split reads = 132
Discordant mates = 6

— translocation — deletion
— duplication — inversion

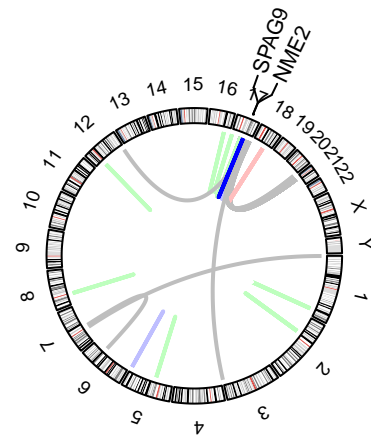
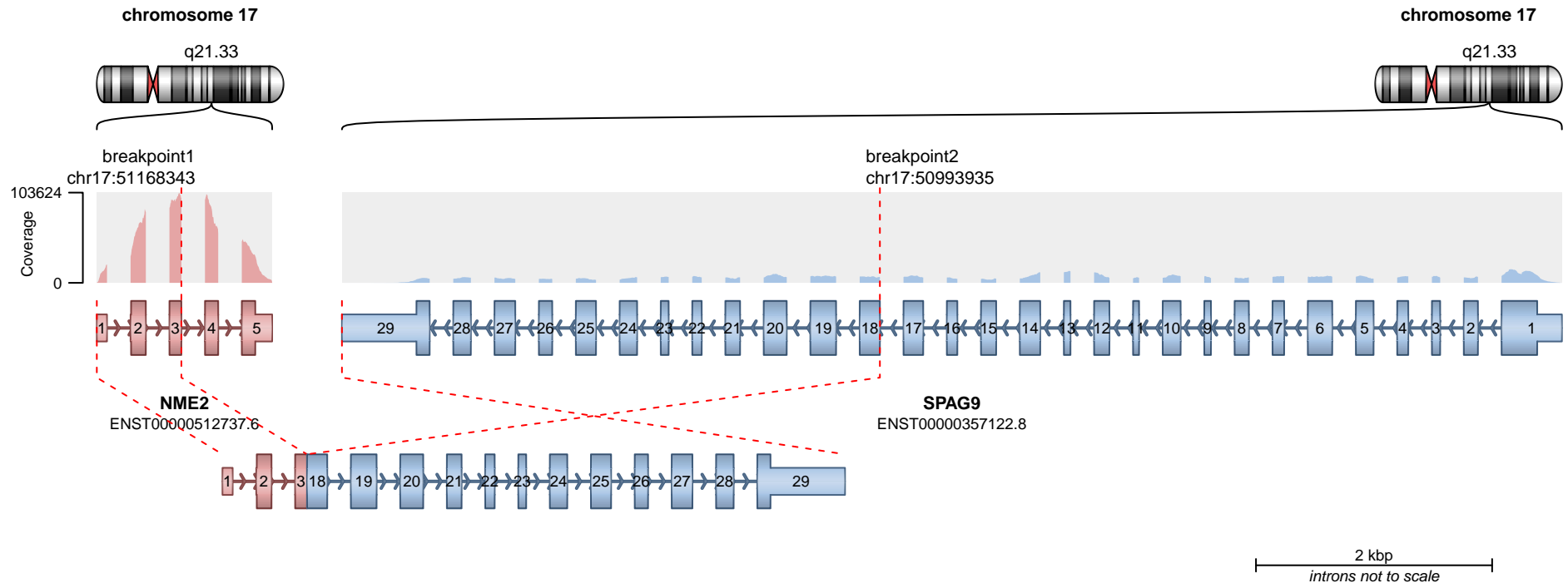

RETAINED PROTEIN DOMAINS
reading frame unclear

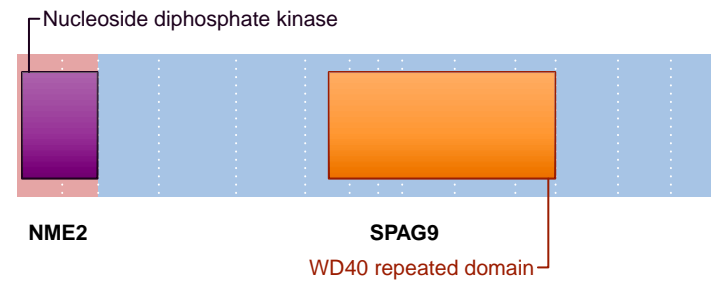

SUPPORTING READ COUNT

Split reads = 63
Discordant mates = 0

- translocation
- duplication
- deletion
- inversion

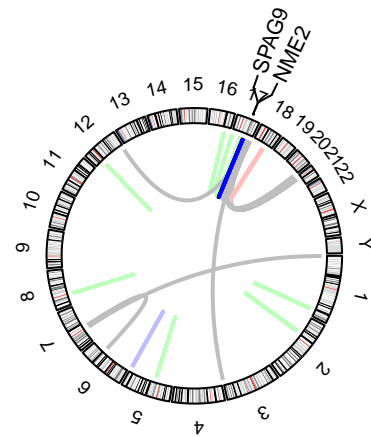
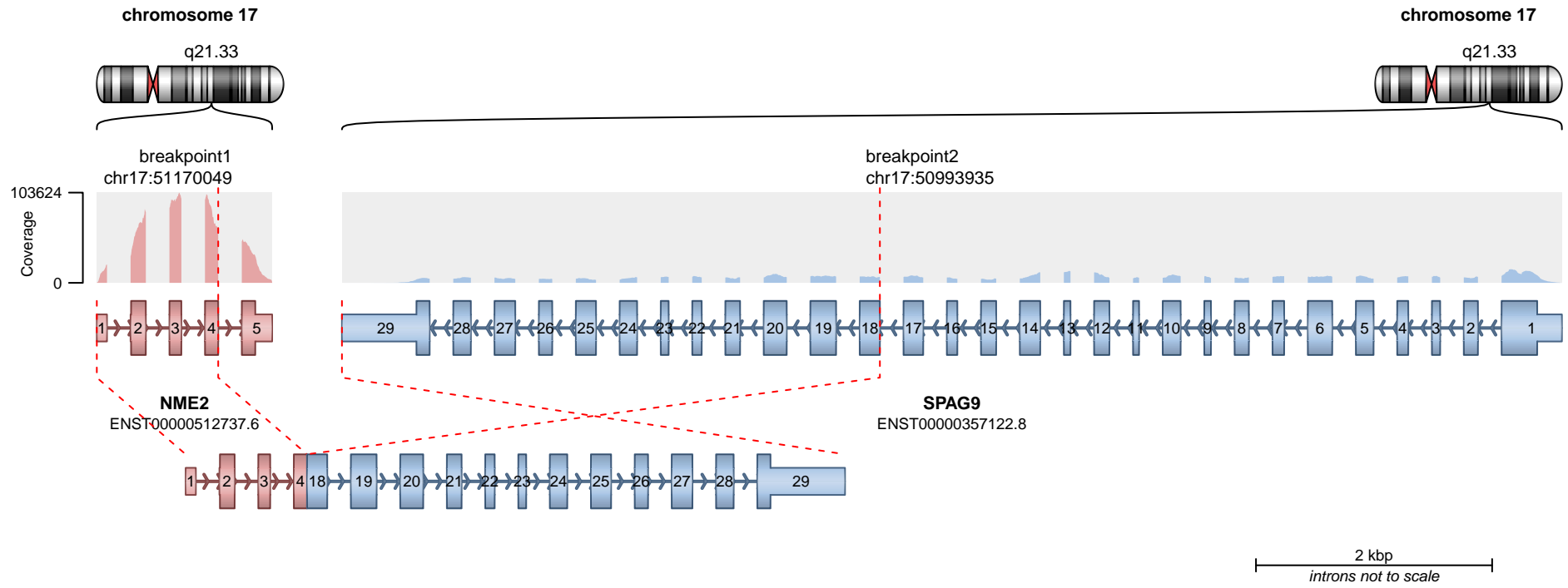

RETAINED PROTEIN DOMAINS
reading frame unclear

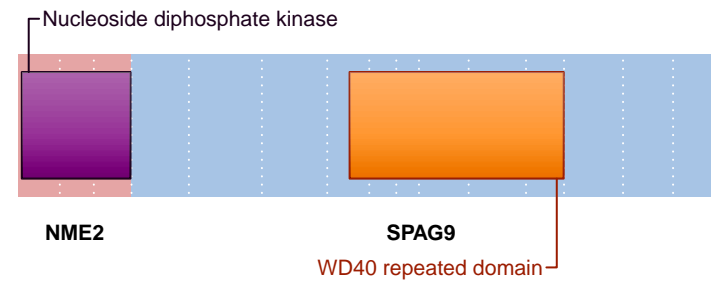

SUPPORTING READ COUNT

Split reads = 2
Discordant mates = 0

- translocation
- duplication
- deletion
- inversion

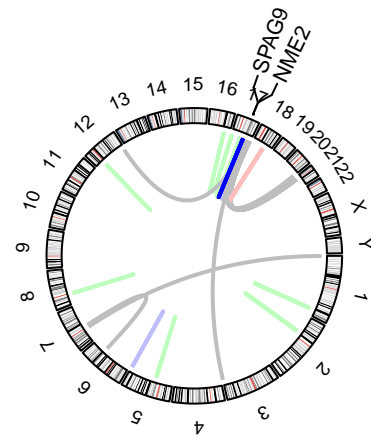
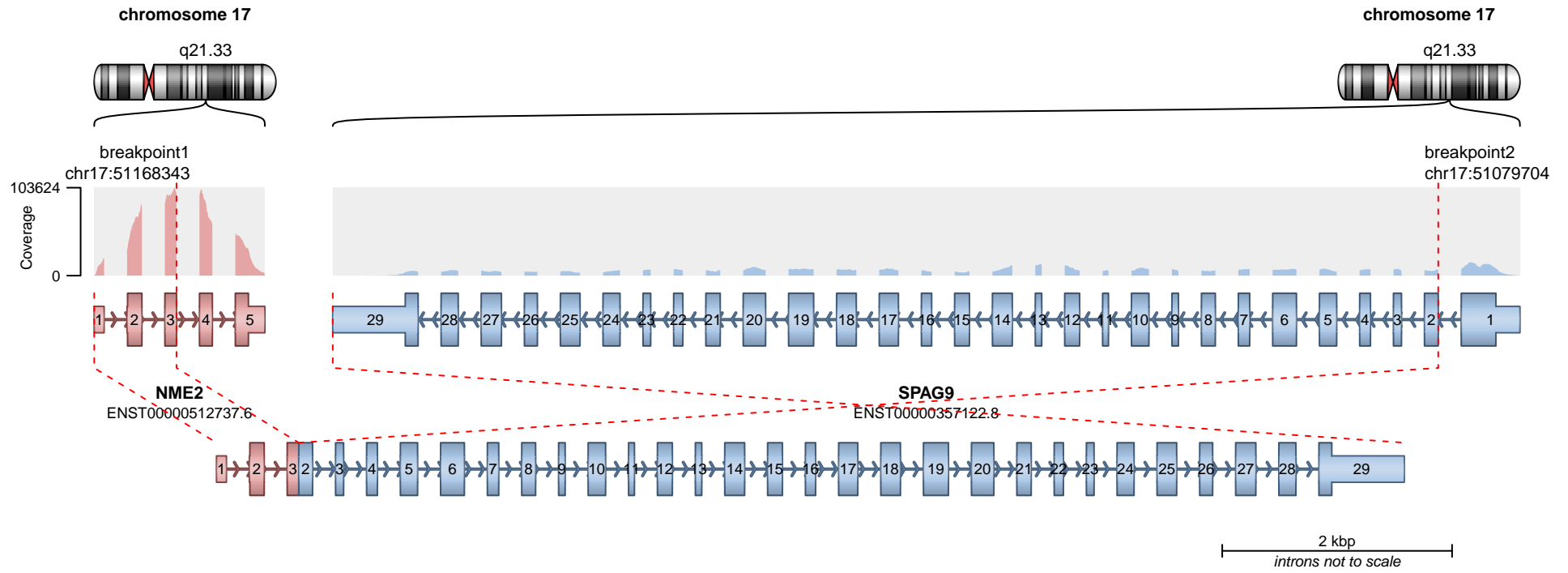

RETAINED PROTEIN DOMAINS
reading frame unclear

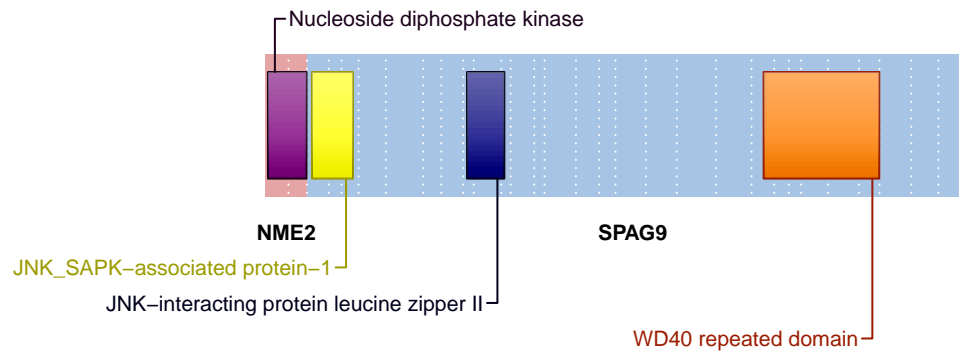

SUPPORTING READ COUNT

Split reads = 1
Discordant mates = 0

- translocation
- duplication
- deletion
- inversion

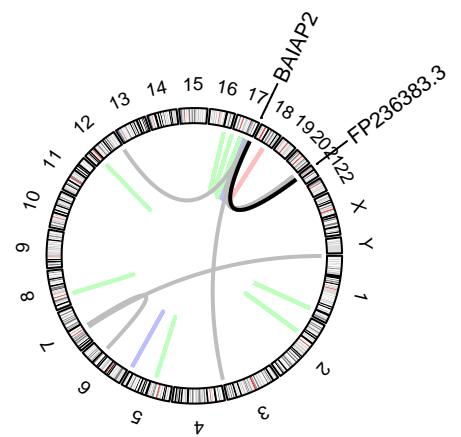
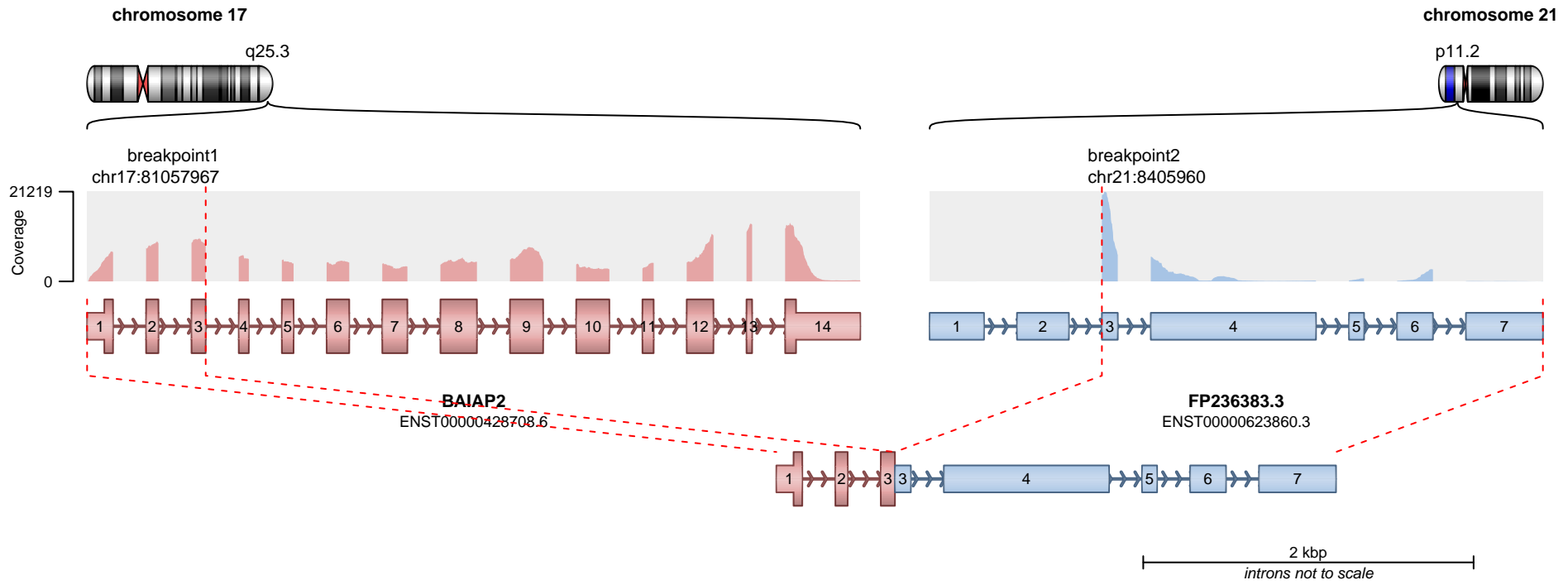

RETAINED PROTEIN DOMAINS
reading frame unclear

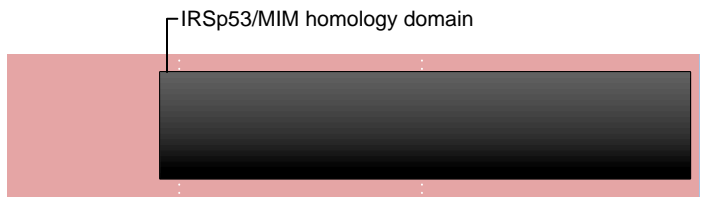

SUPPORTING READ COUNT

Split reads = 59
Discordant mates = 0

- translocation
- duplication
- deletion
- inversion

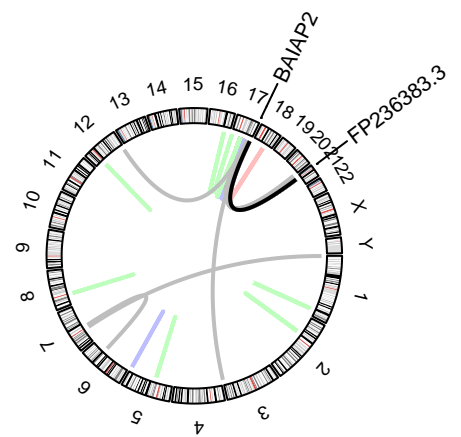
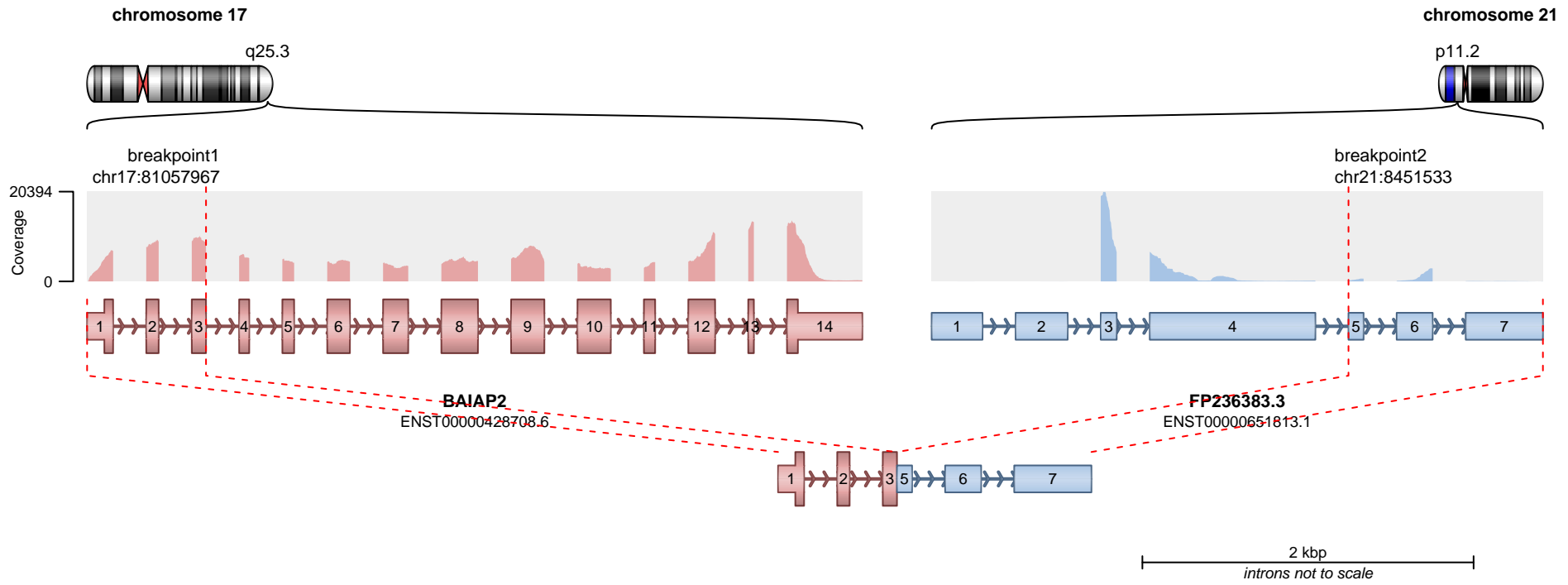

RETAINED PROTEIN DOMAINS
reading frame unclear

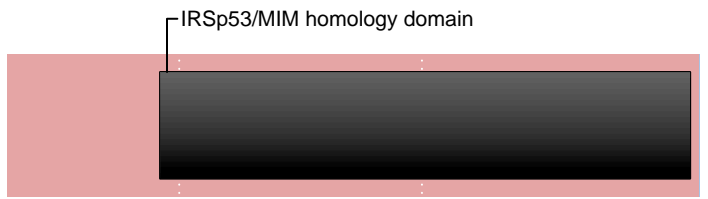

BAIAP2

SUPPORTING READ COUNT

Split reads = 9
Discordant mates = 0

- translocation
- duplication
- deletion
- inversion

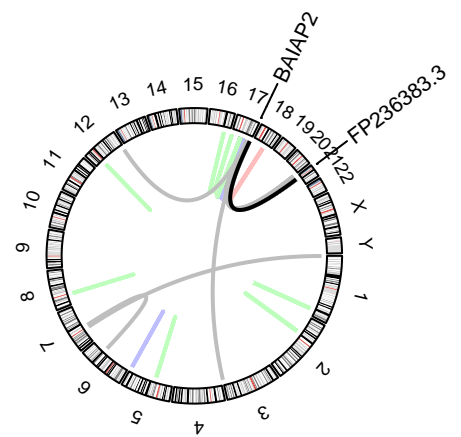
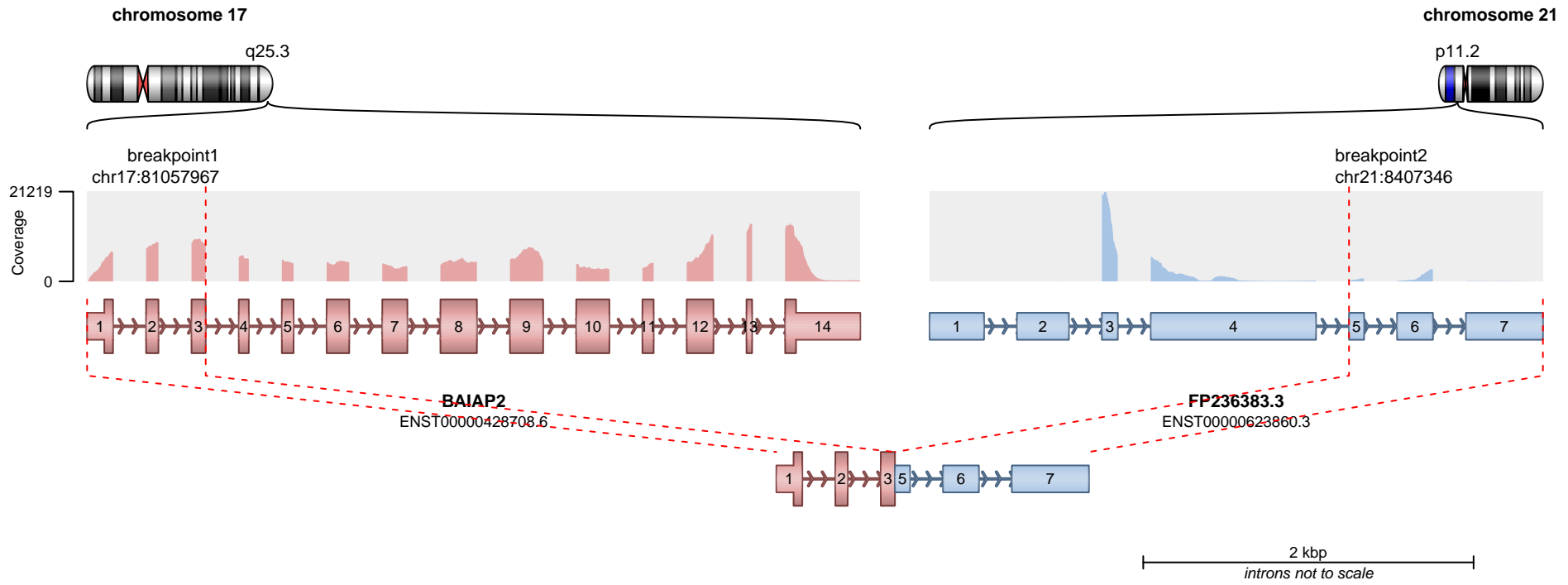

RETAINED PROTEIN DOMAINS
reading frame unclear

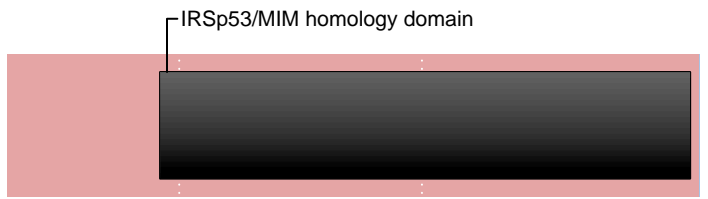

BAIAP2

SUPPORTING READ COUNT

Split reads = 9
Discordant mates = 0

- translocation
- duplication
- deletion
- inversion

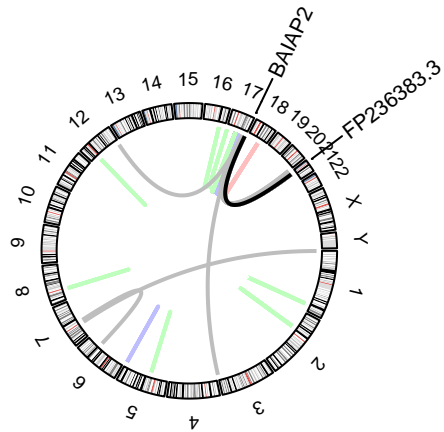
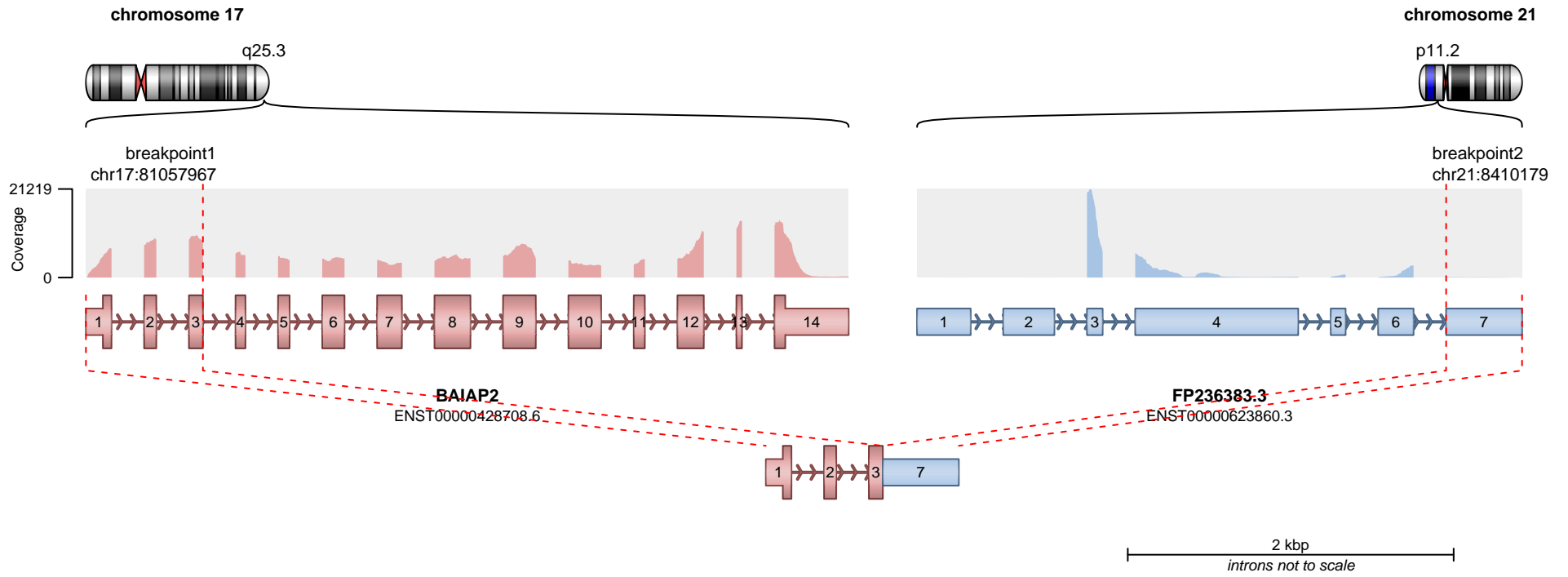

RETAINED PROTEIN DOMAINS
reading frame unclear

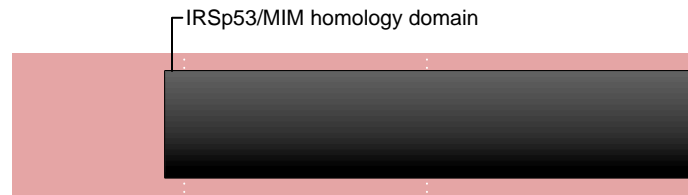

SUPPORTING READ COUNT

Split reads = 5
Discordant mates = 0

- translocation
- duplication
- deletion
- inversion

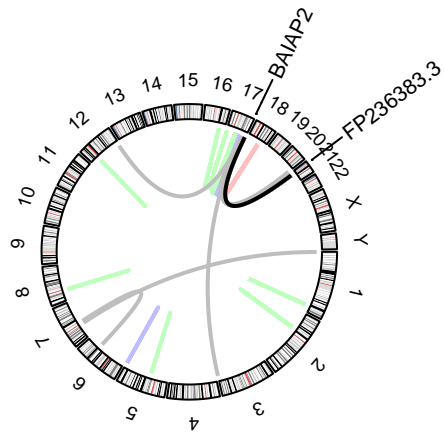
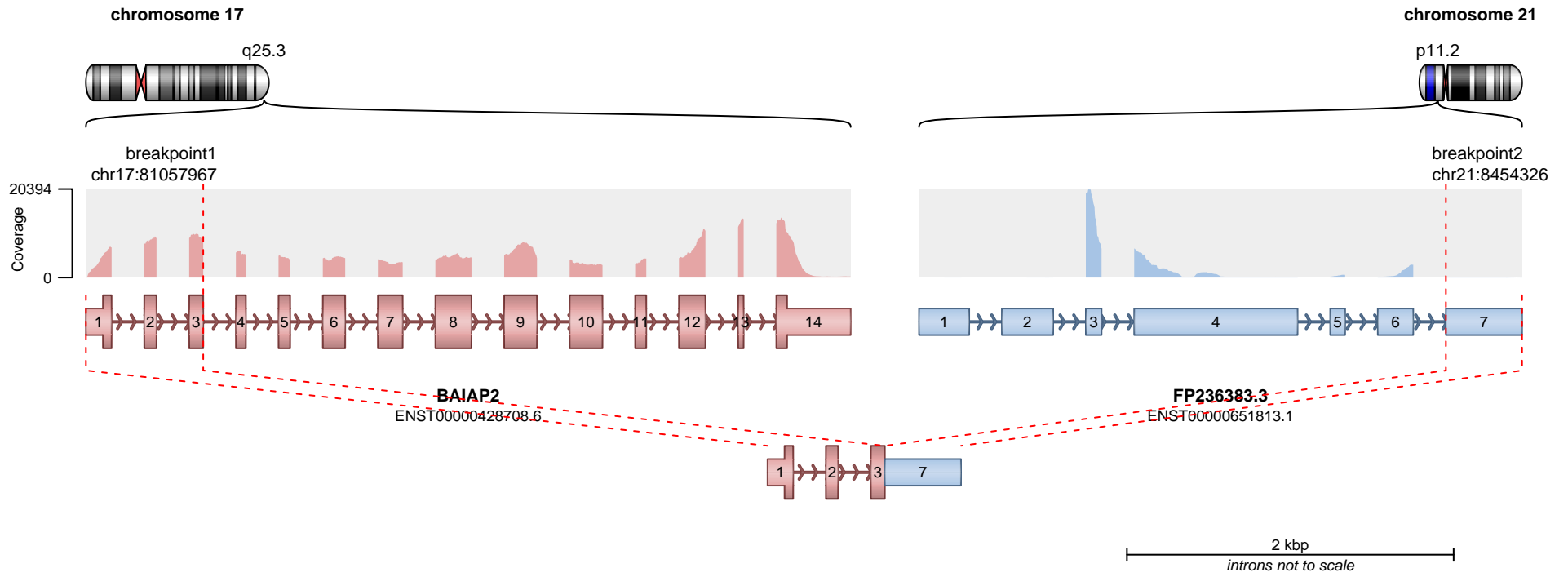

RETAINED PROTEIN DOMAINS
reading frame unclear

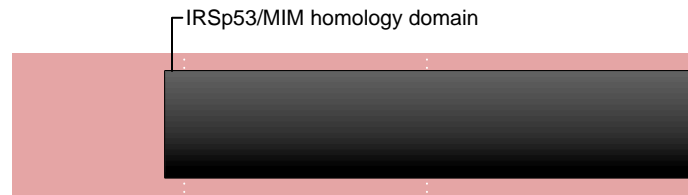

SUPPORTING READ COUNT

Split reads = 5
Discordant mates = 0

- translocation
- duplication
- deletion
- inversion

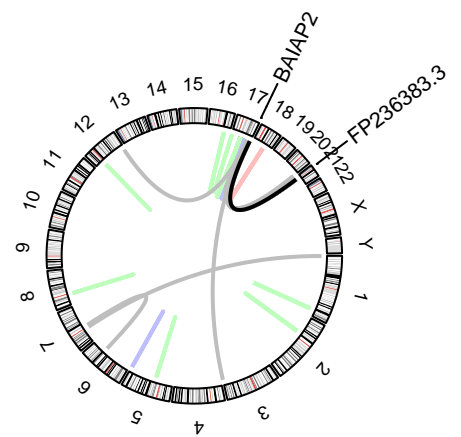
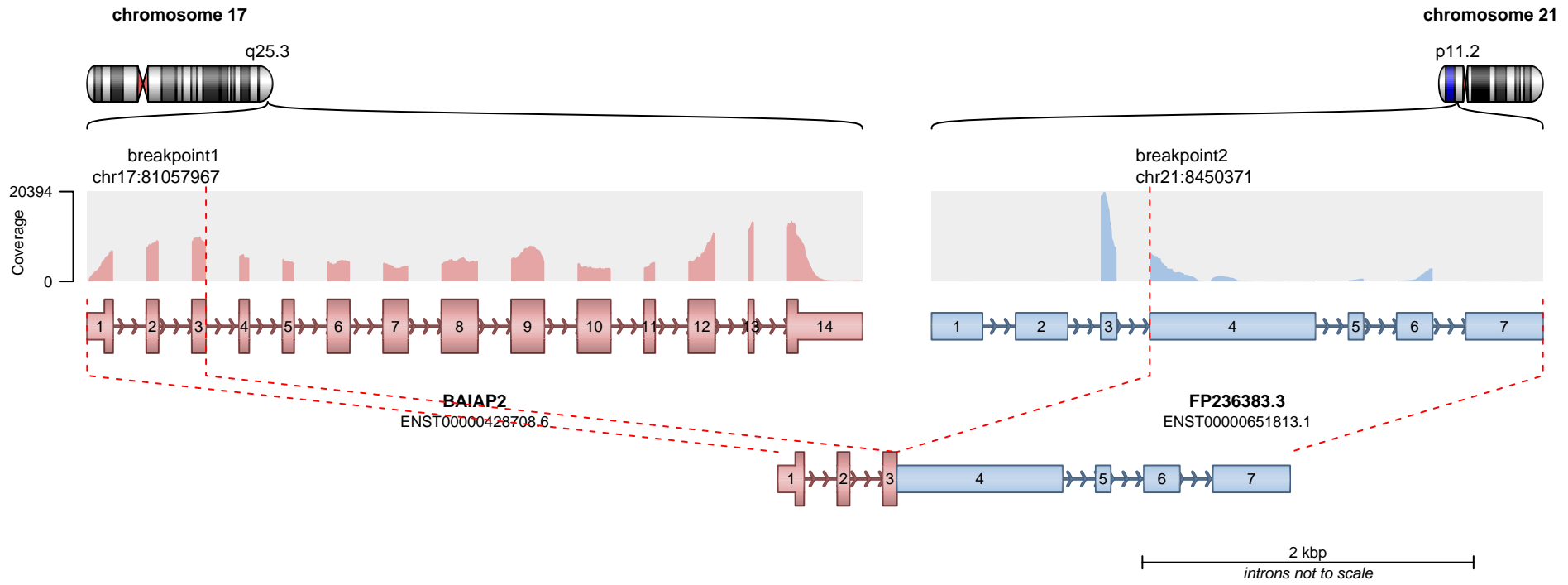

RETAINED PROTEIN DOMAINS
reading frame unclear

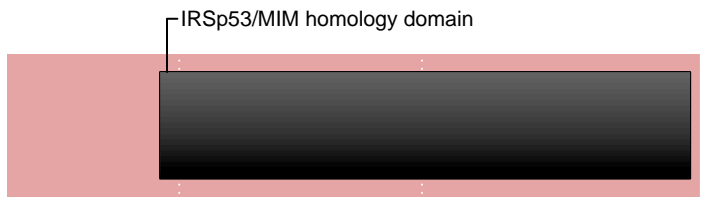

SUPPORTING READ COUNT

Split reads = 4
Discordant mates = 0

- translocation
- duplication
- deletion
- inversion

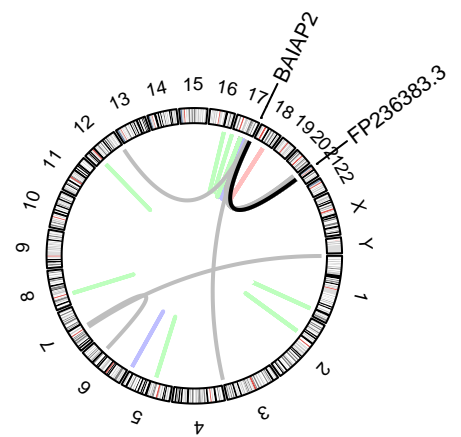
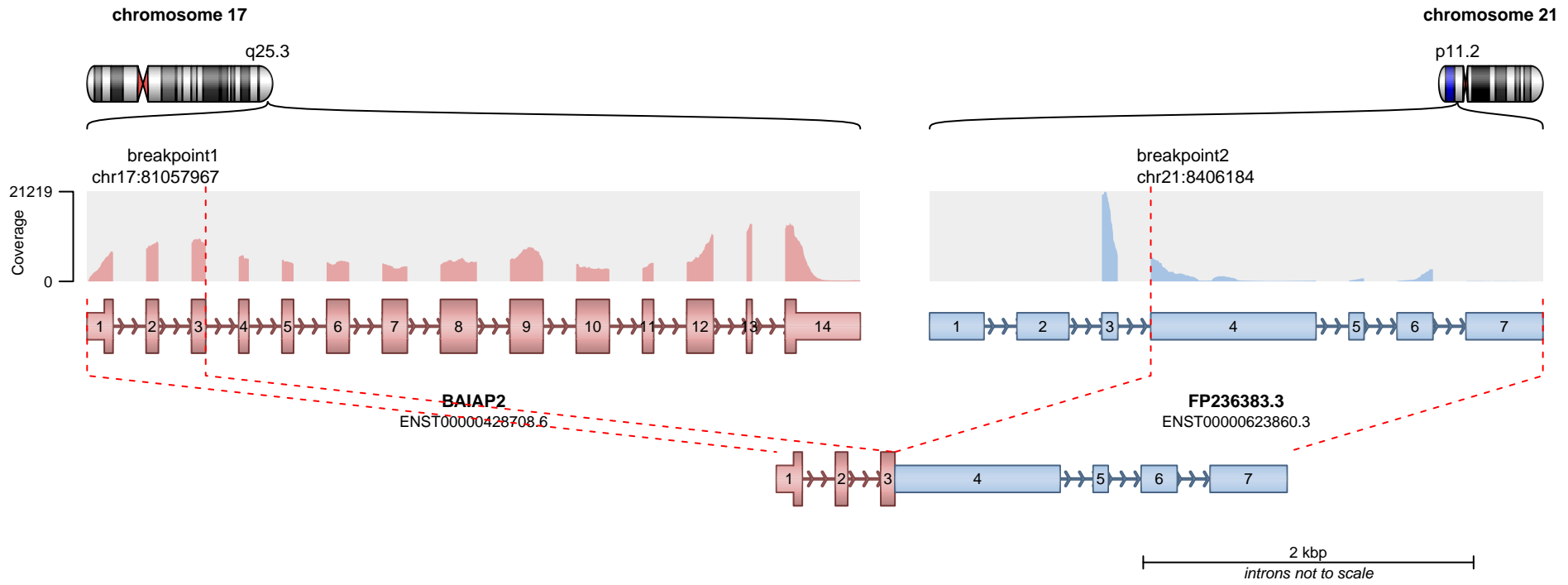

RETAINED PROTEIN DOMAINS
reading frame unclear

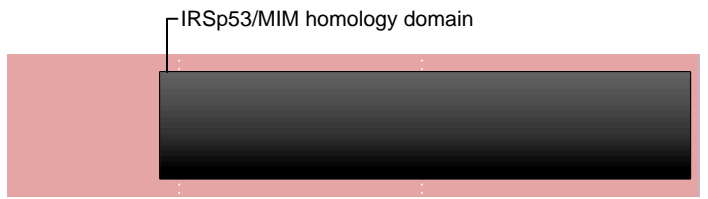

BAIAP2

SUPPORTING READ COUNT

Split reads = 4
Discordant mates = 0

- translocation
- duplication
- deletion
- inversion

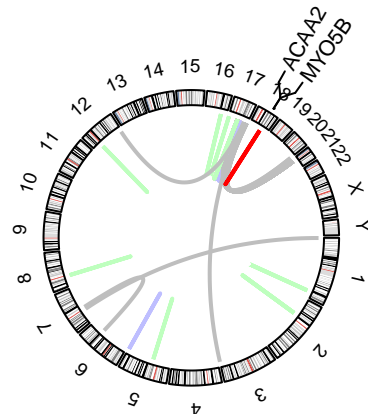
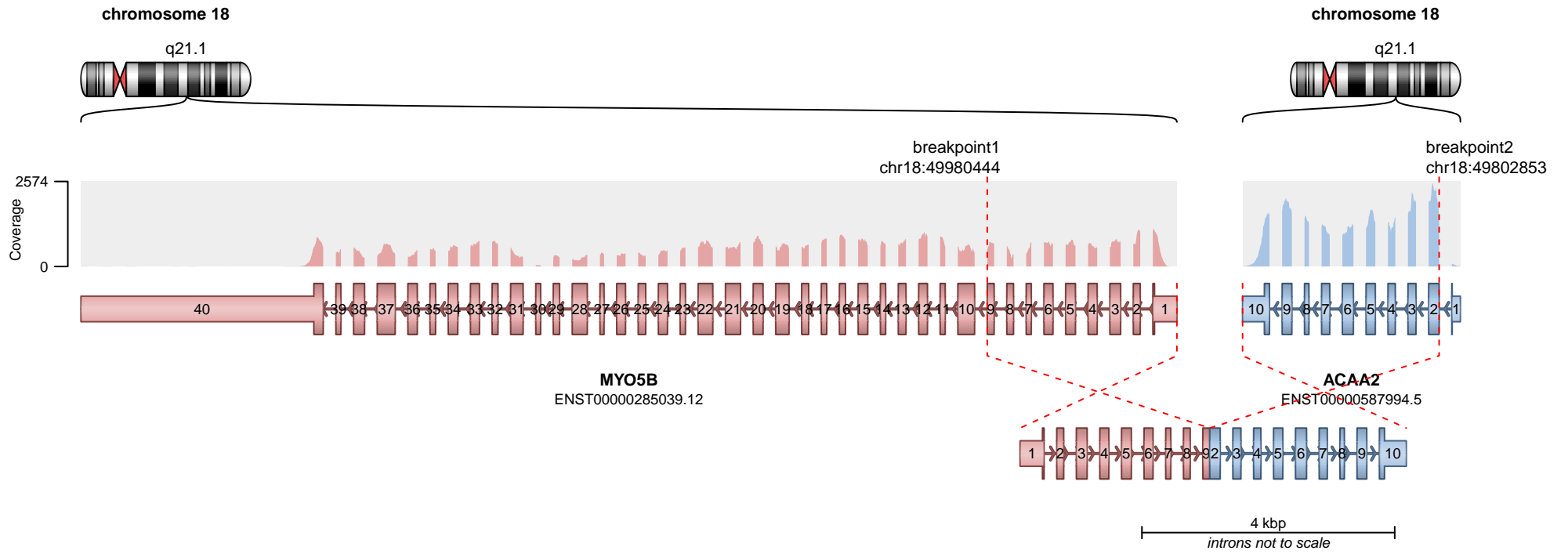

RETAINED PROTEIN DOMAINS
reading frame unclear

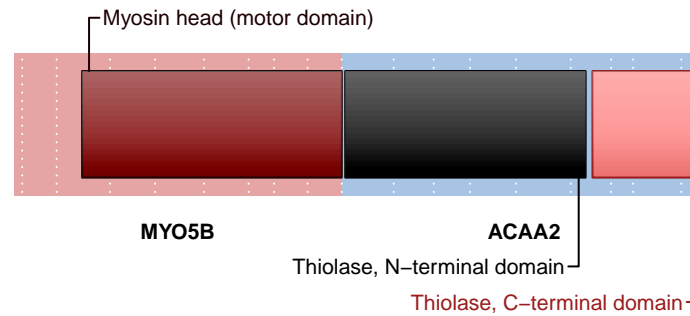

SUPPORTING READ COUNT

Split reads = 37
Discordant mates = 5

- translocation
- duplication
- deletion
- inversion

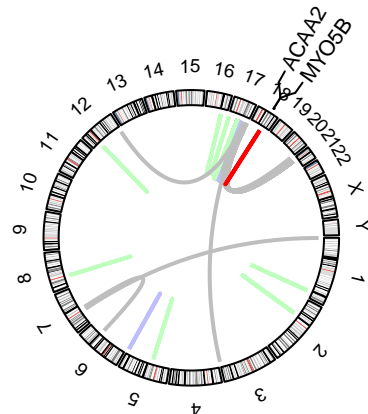
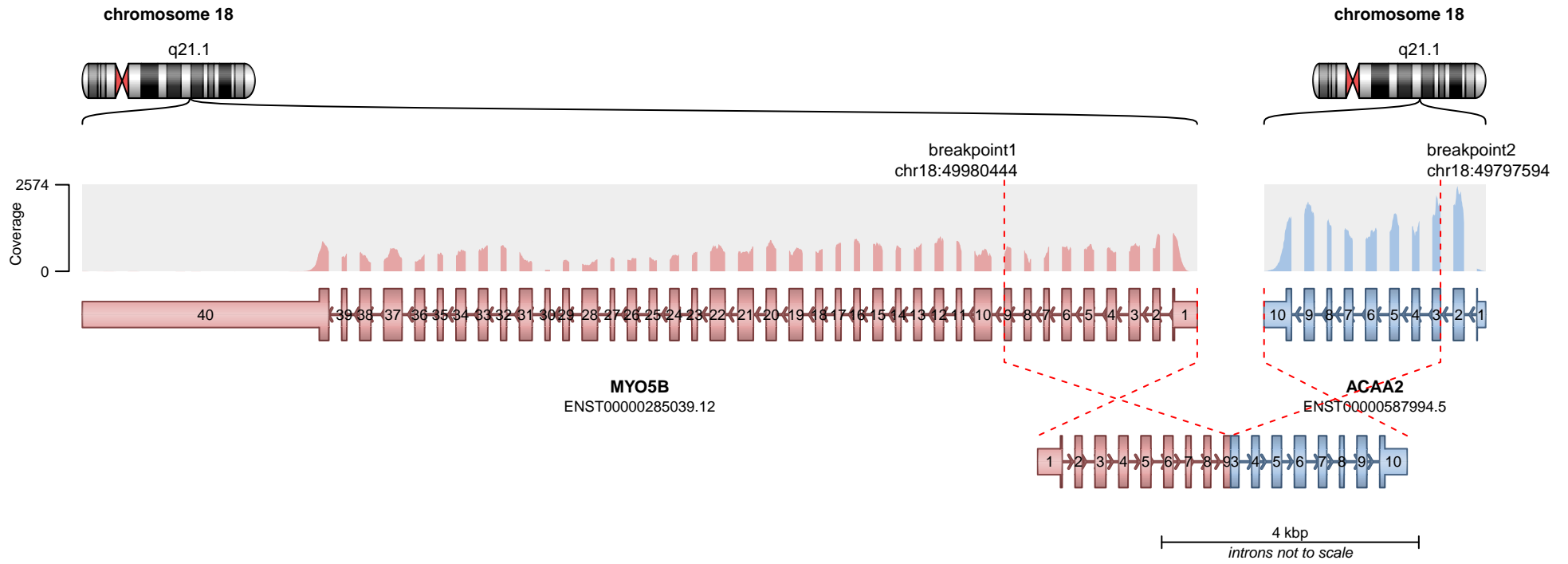

RETAINED PROTEIN DOMAINS
reading frame unclear

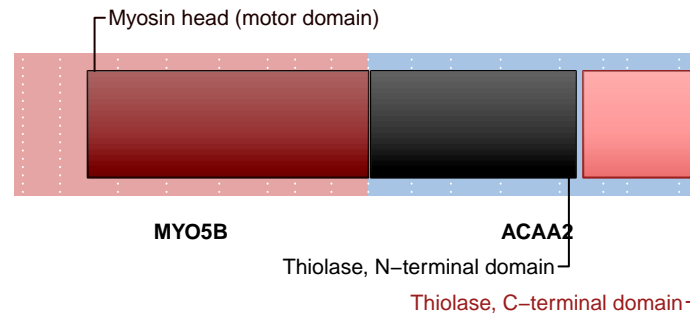

SUPPORTING READ COUNT

Split reads = 2
Discordant mates = 0

- translocation
- duplication
- deletion
- inversion

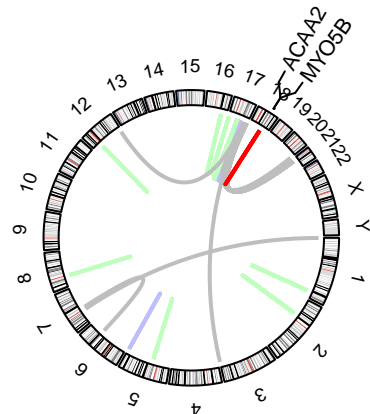
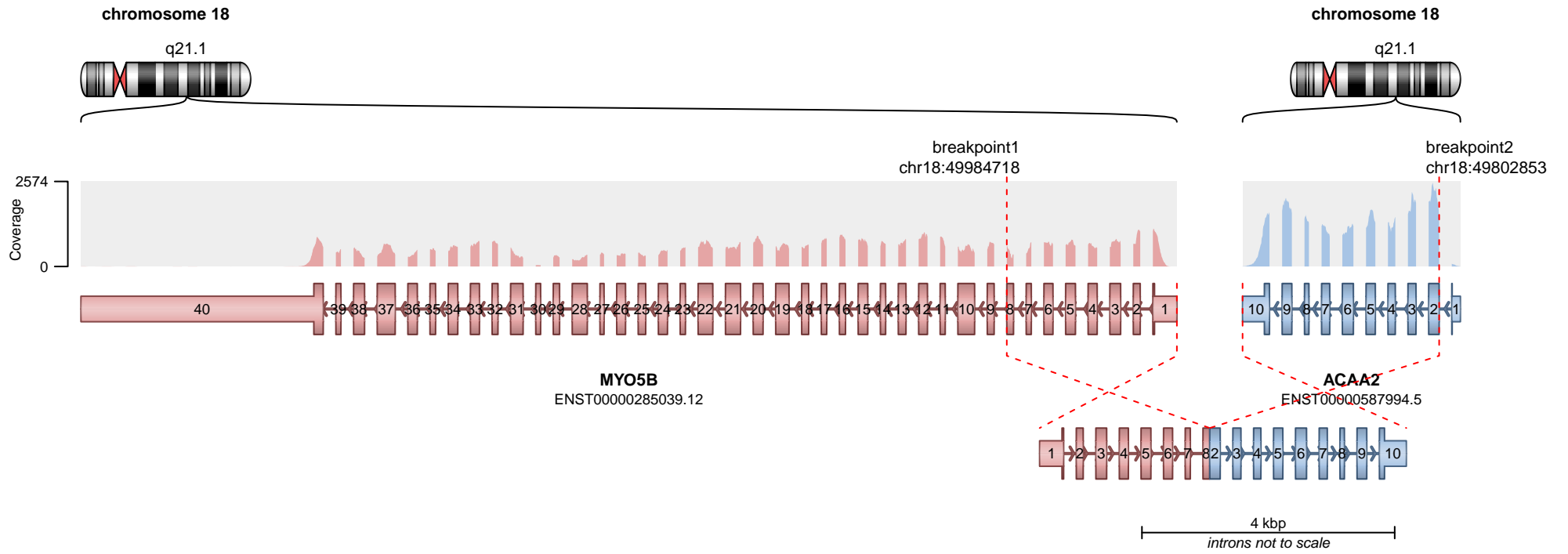

RETAINED PROTEIN DOMAINS
reading frame unclear

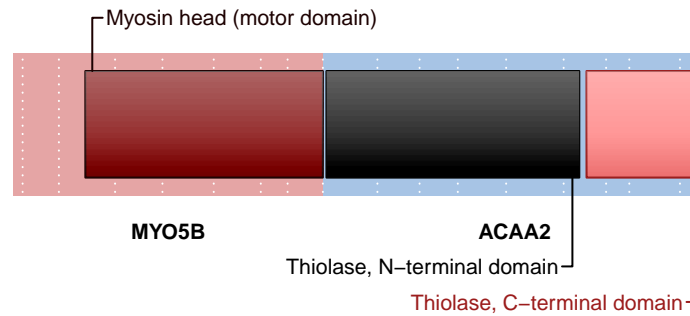

SUPPORTING READ COUNT

Split reads = 1
Discordant mates = 0

- translocation
- duplication
- deletion
- inversion

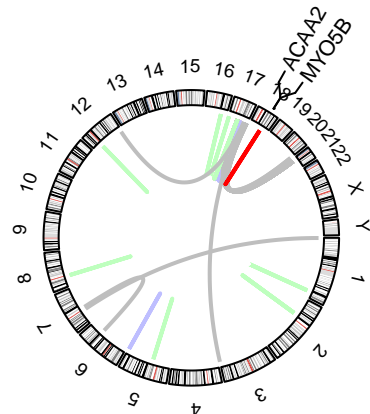
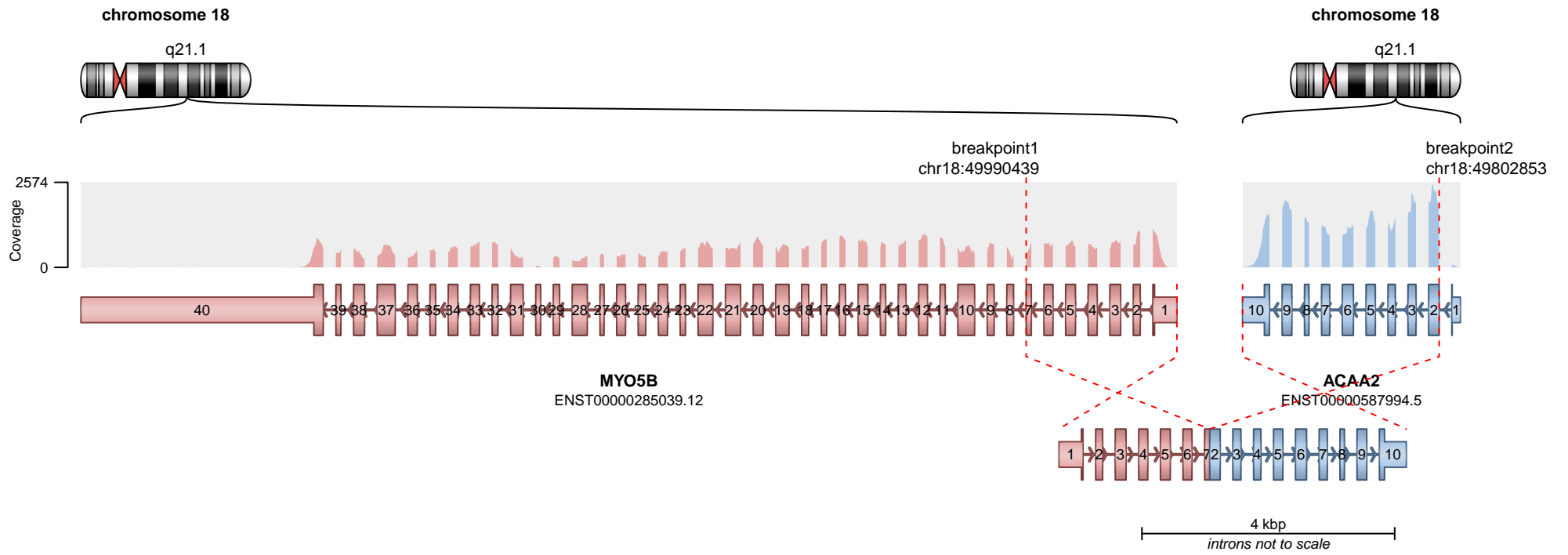

RETAINED PROTEIN DOMAINS
reading frame unclear

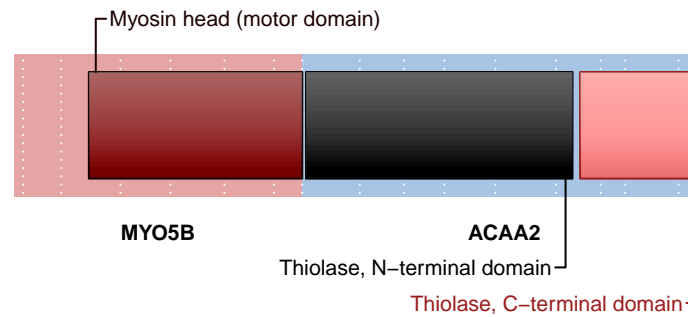

SUPPORTING READ COUNT

Split reads = 1
Discordant mates = 0

- translocation
- duplication
- deletion
- inversion

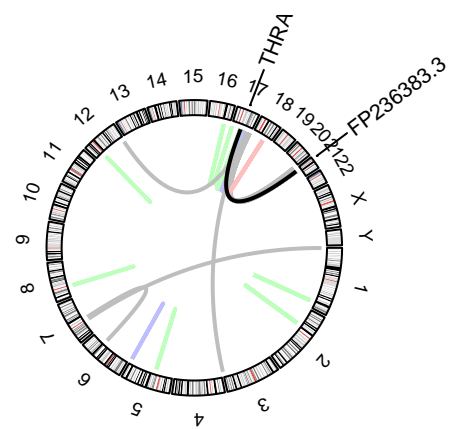
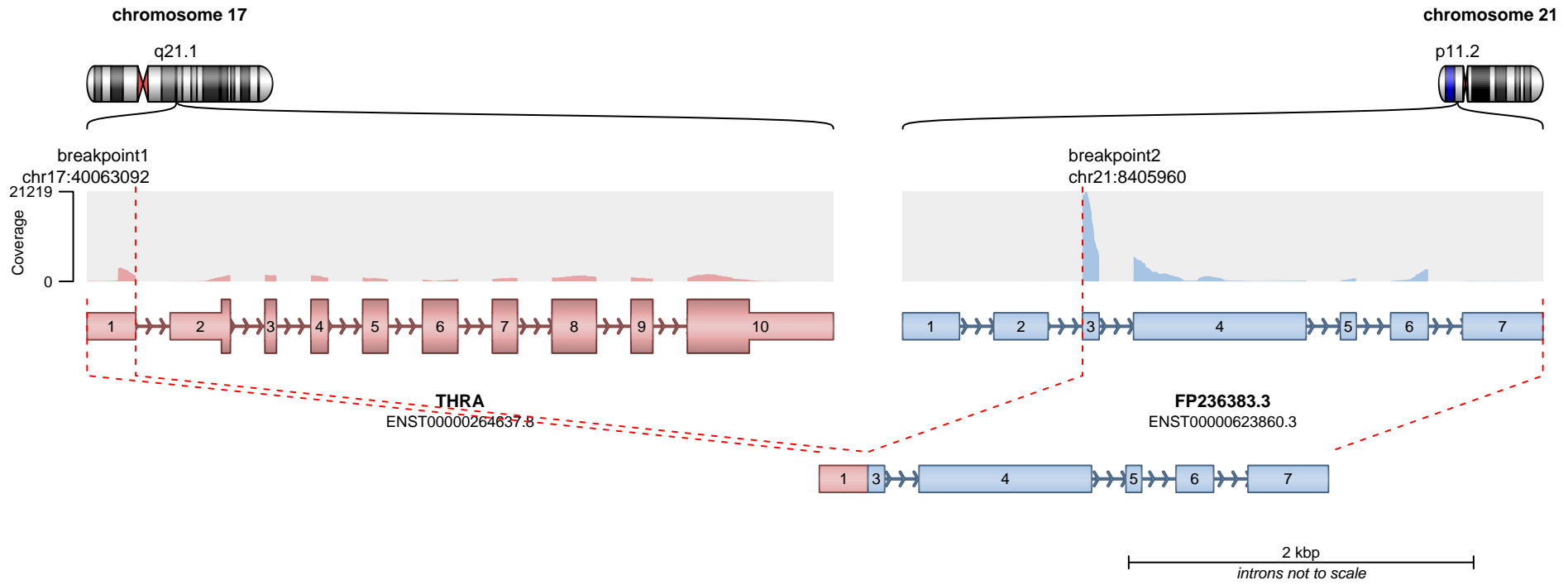

— translocation — deletion
— duplication — inversion

No coding regions retained in fusion transcript.

SUPPORTING READ COUNT

Split reads = 32
Discordant mates = 0

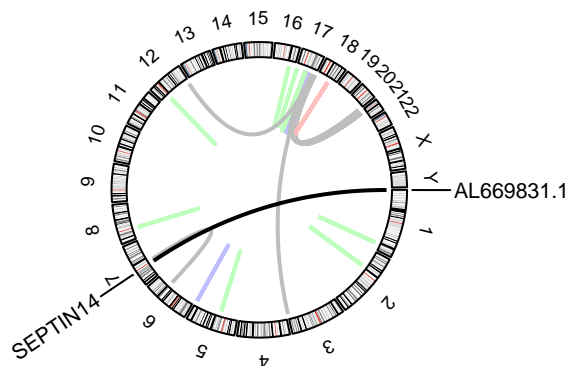
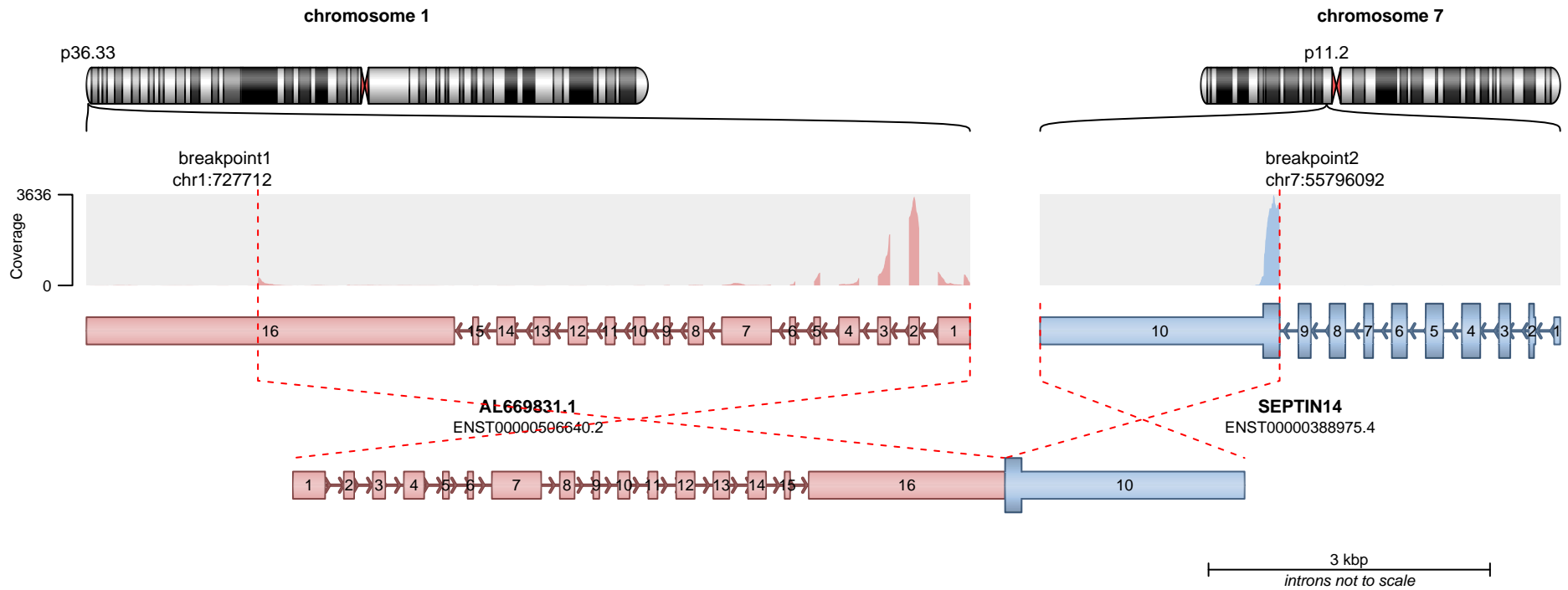

No protein domains retained in fusion.

SUPPORTING READ COUNT

Split reads = 28
Discordant mates = 1

- translocation
- duplication
- deletion
- inversion

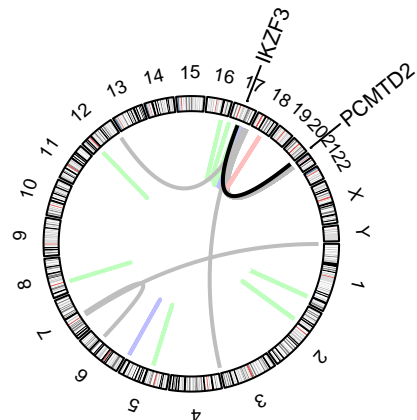
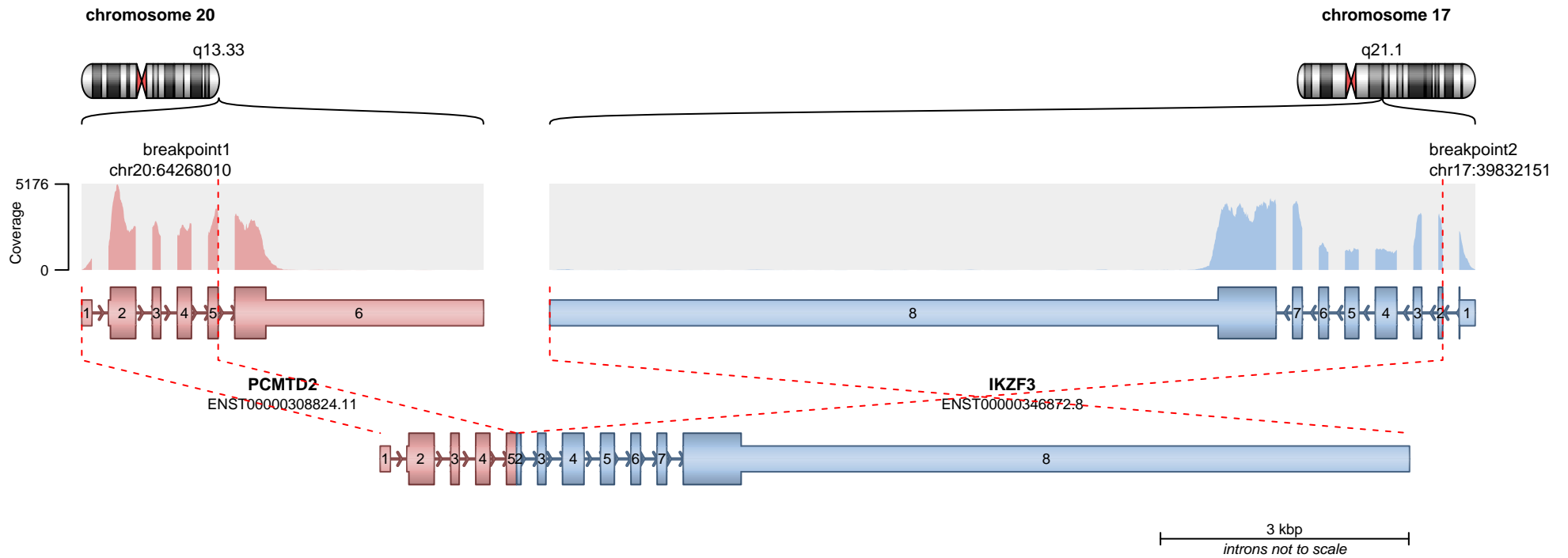

RETAINED PROTEIN DOMAINS
reading frame unclear

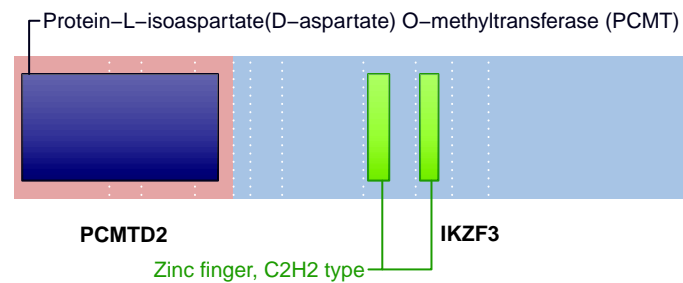

SUPPORTING READ COUNT

Split reads = 27
Discordant mates = 1

— translocation — deletion
— duplication — inversion

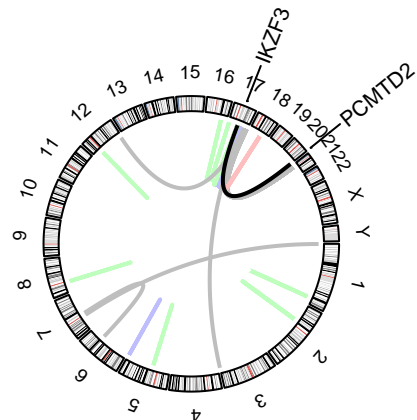
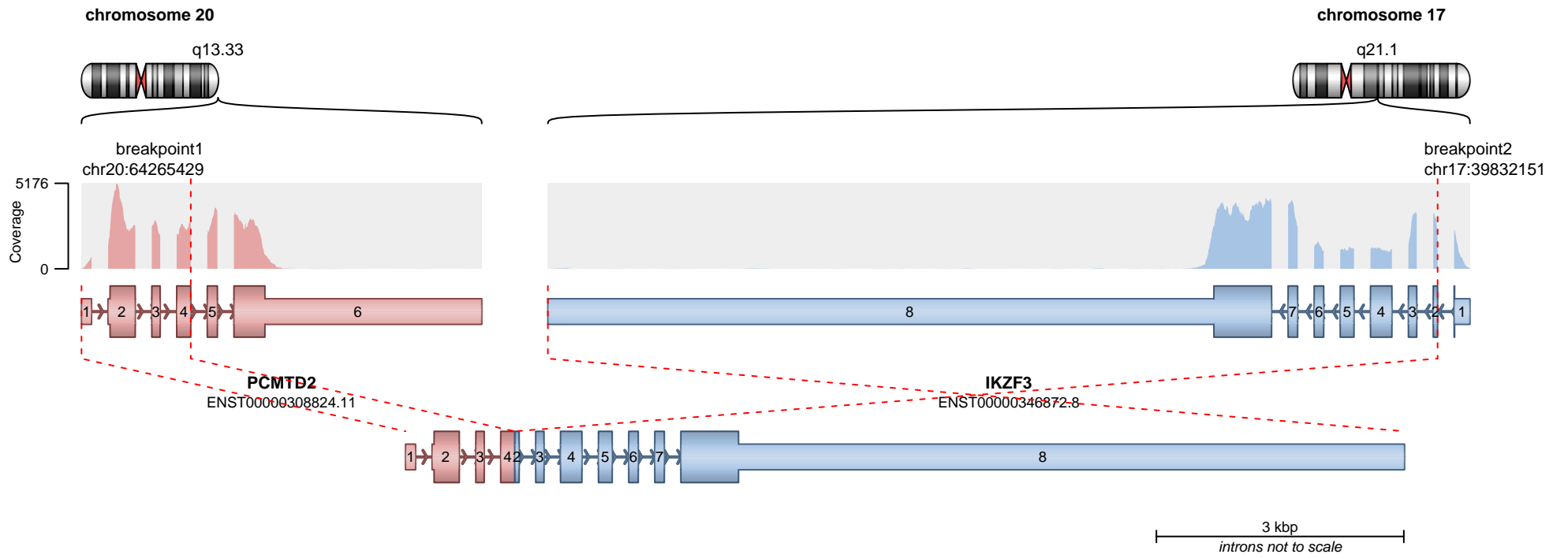

RETAINED PROTEIN DOMAINS
reading frame unclear

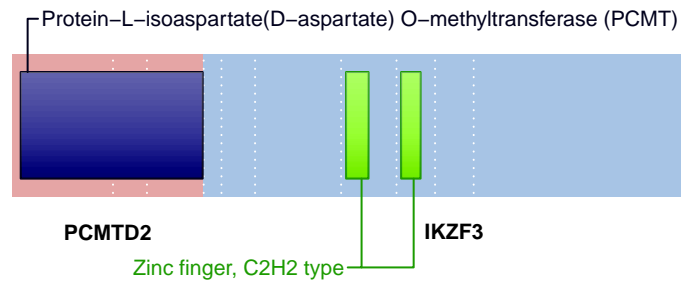

SUPPORTING READ COUNT

Split reads = 1
Discordant mates = 0

— translocation — deletion
— duplication — inversion

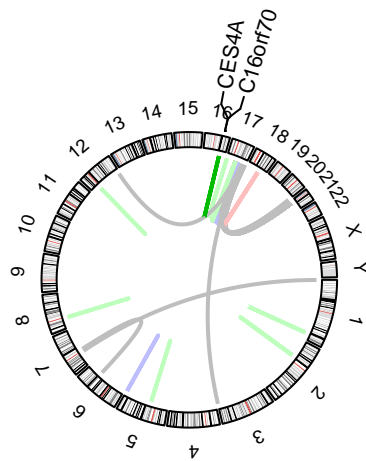
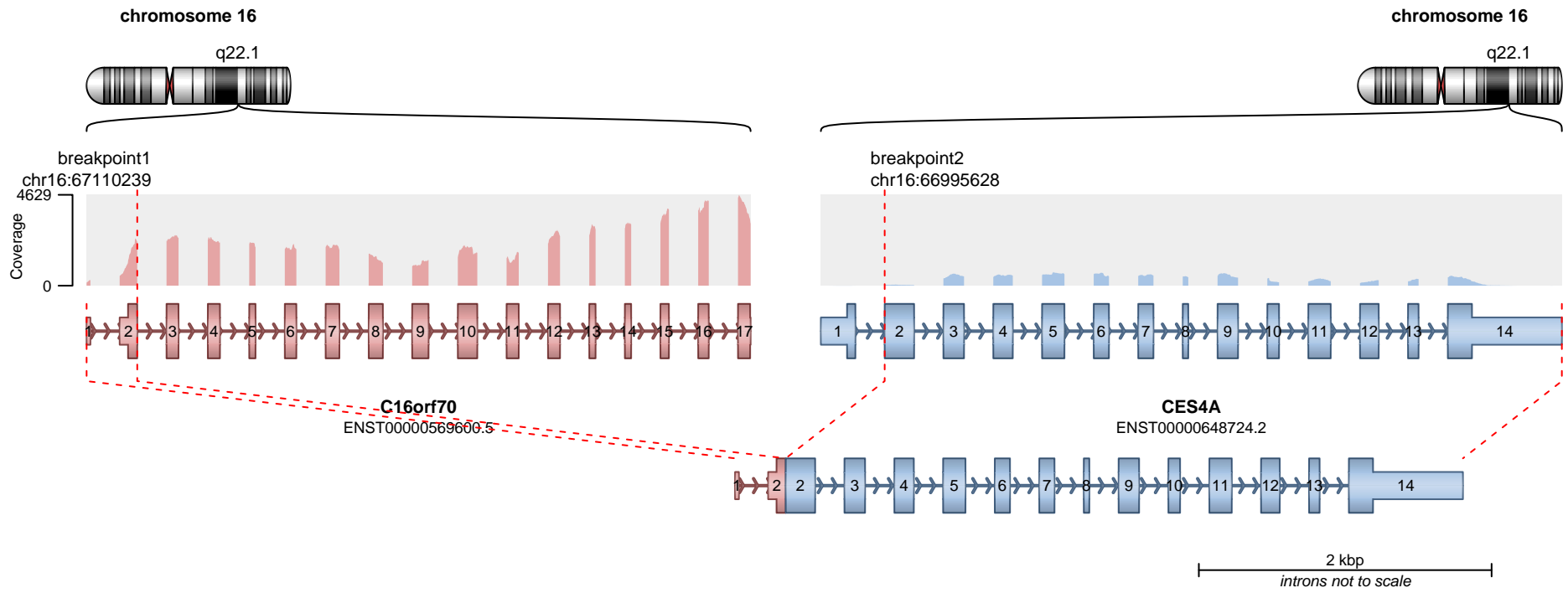

RETAINED PROTEIN DOMAINS
reading frame unclear

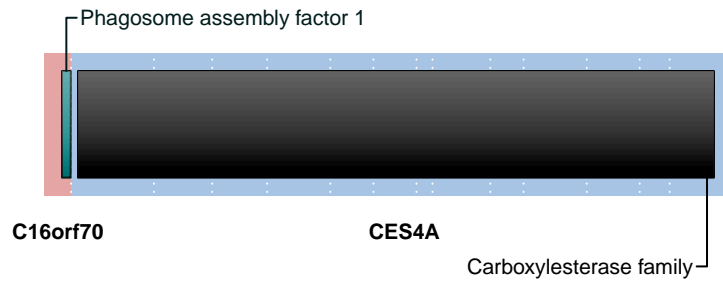

SUPPORTING READ COUNT

Split reads = 24
Discordant mates = 1

- translocation
- duplication
- deletion
- inversion

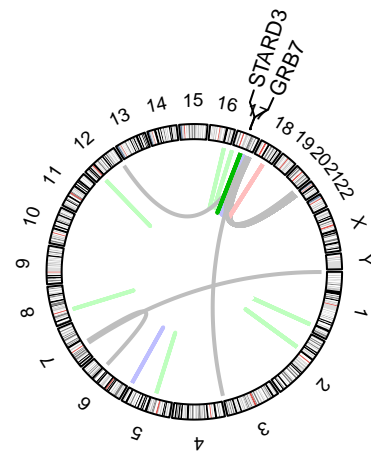
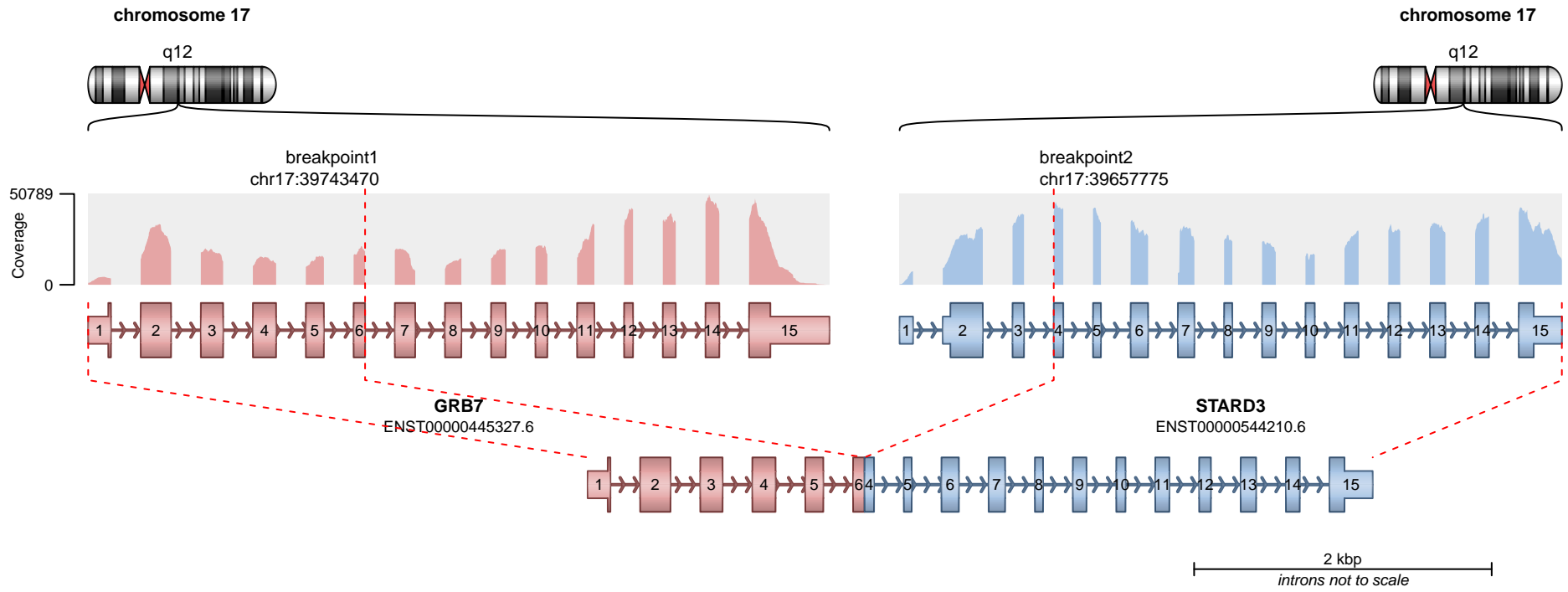

RETAINED PROTEIN DOMAINS
reading frame unclear

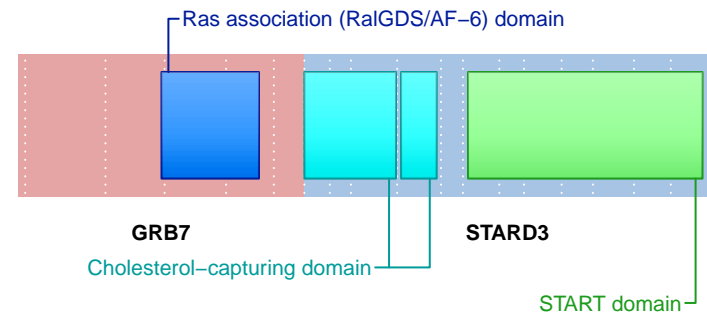

SUPPORTING READ COUNT

Split reads = 24
Discordant mates = 1

- translocation
- duplication
- deletion
- inversion

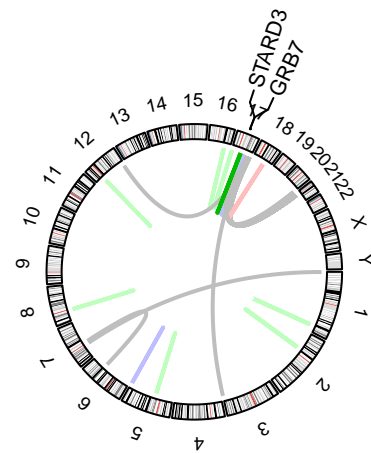
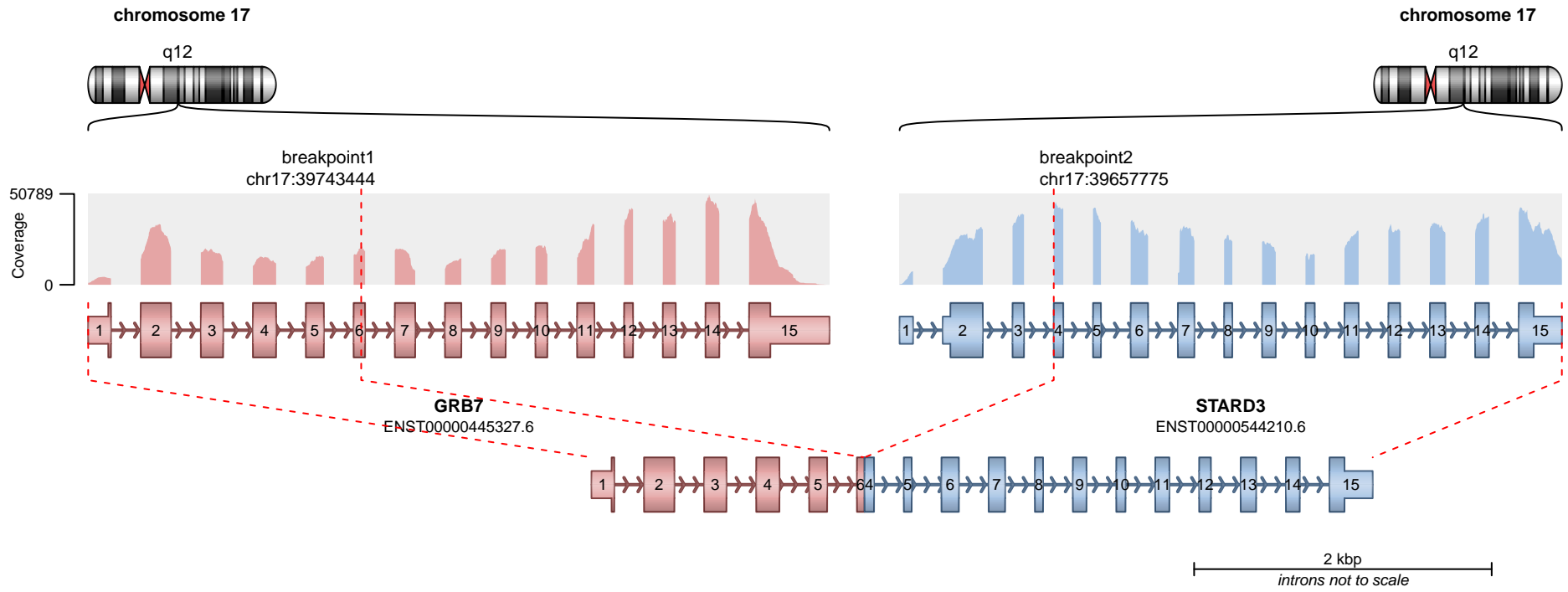

RETAINED PROTEIN DOMAINS
reading frame unclear

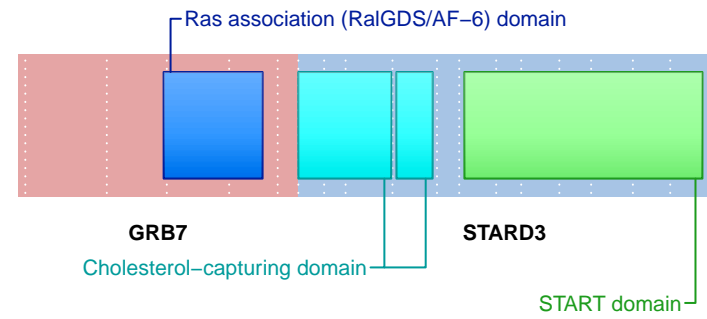

SUPPORTING READ COUNT

Split reads = 5
Discordant mates = 1

- translocation
- duplication
- deletion
- inversion

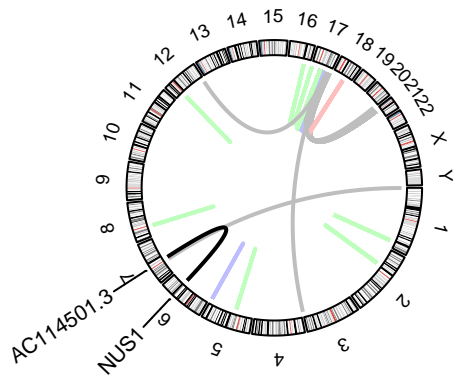
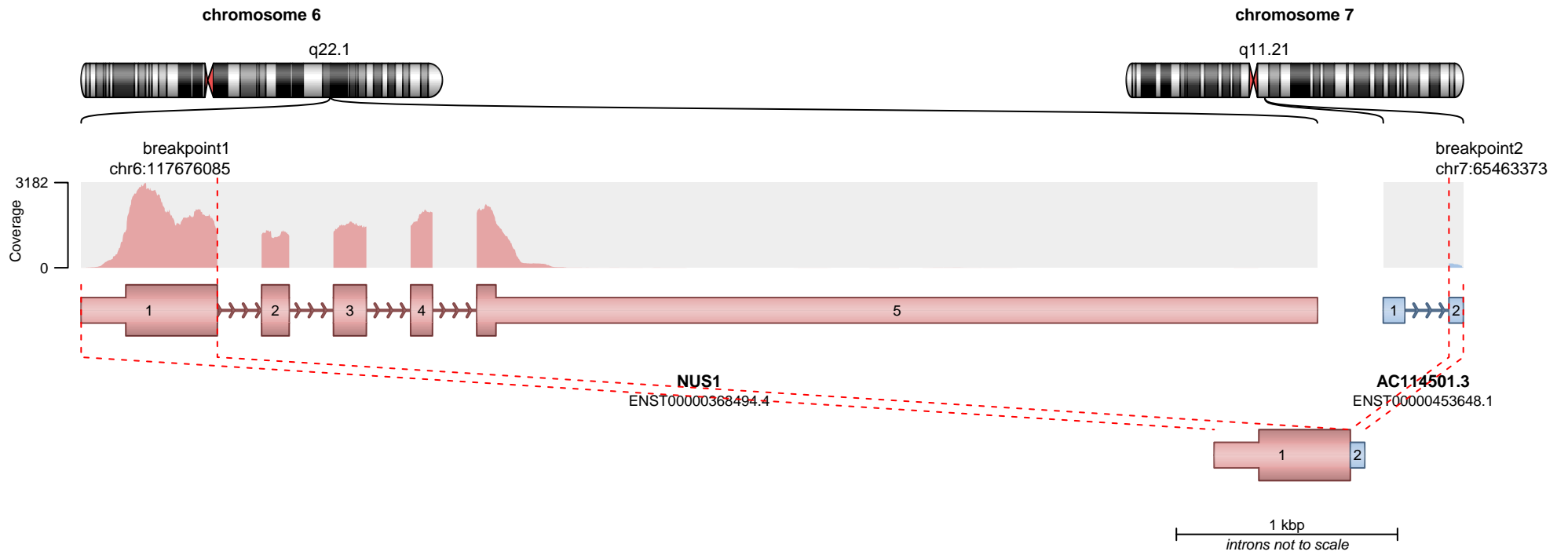

— translocation — deletion
— duplication — inversion

No protein domains retained in fusion.

SUPPORTING READ COUNT

Split reads = 24
Discordant mates = 0

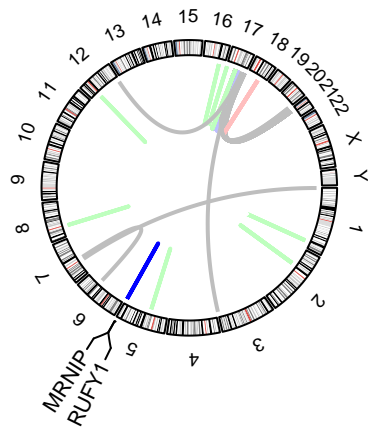
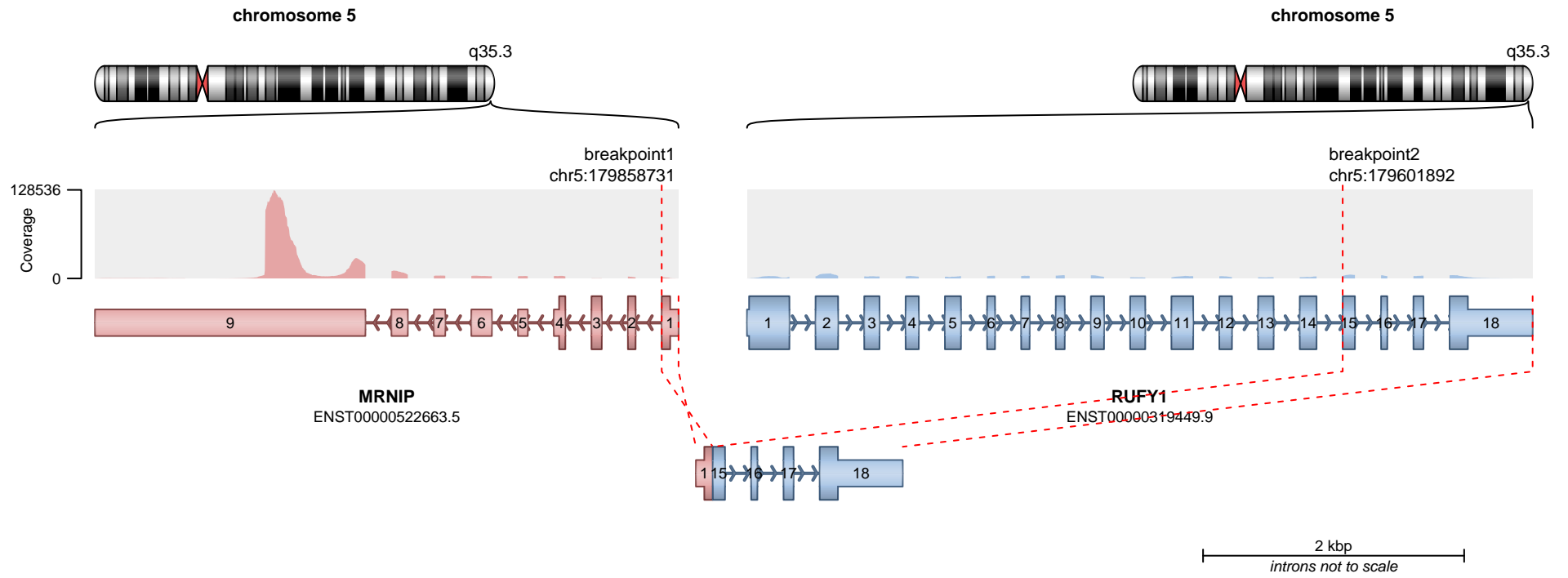

— translocation — deletion
— duplication — inversion

RETAINED PROTEIN DOMAINS
reading frame unclear

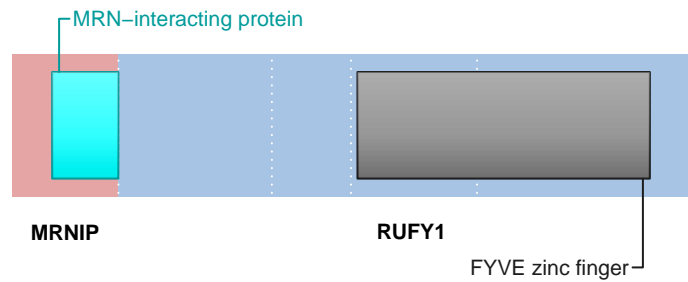

SUPPORTING READ COUNT

Split reads = 19
Discordant mates = 0

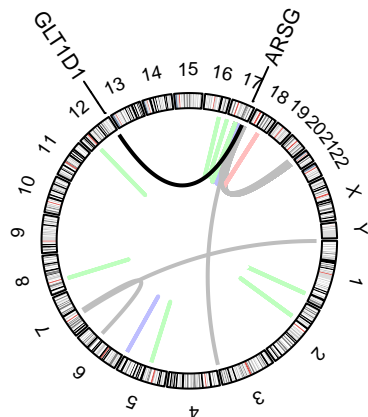
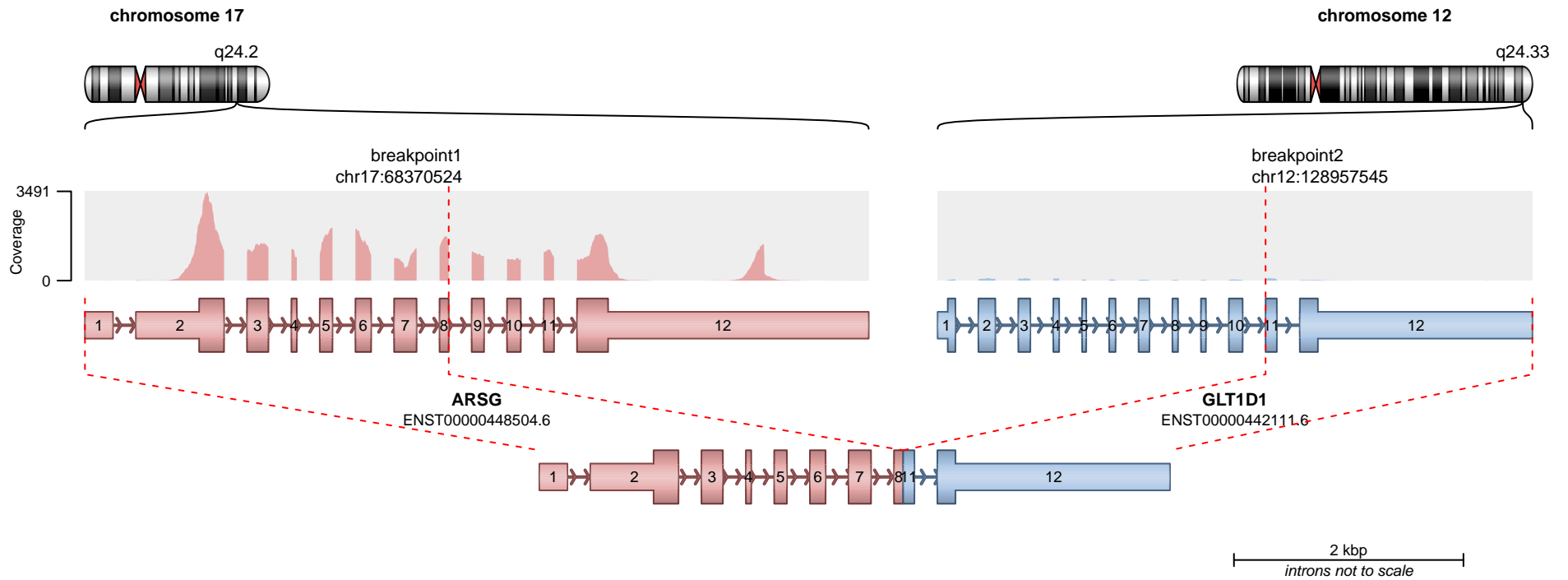

RETAINED PROTEIN DOMAINS
reading frame unclear

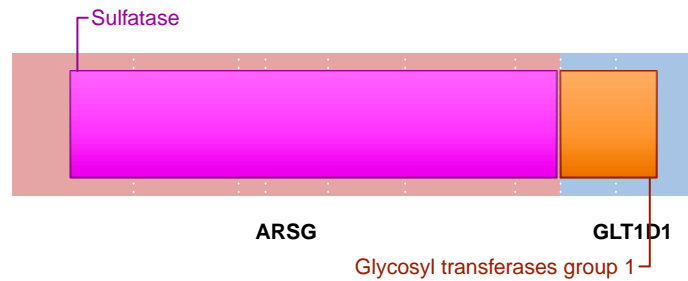

SUPPORTING READ COUNT

Split reads = 18
Discordant mates = 0

- translocation
- duplication
- deletion
- inversion

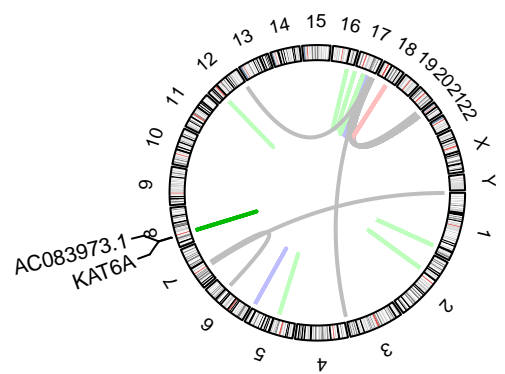
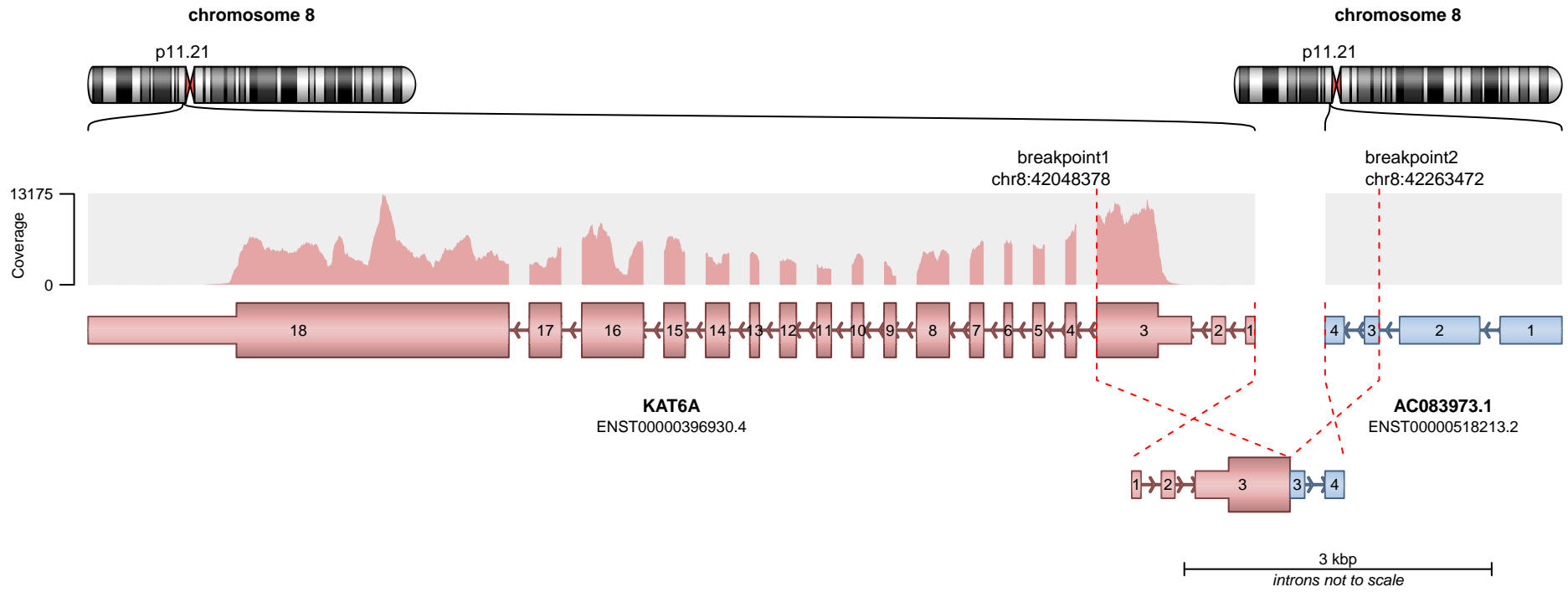

— translocation — deletion
— duplication — inversion

No protein domains retained in fusion.

SUPPORTING READ COUNT

Split reads = 13
Discordant mates = 0

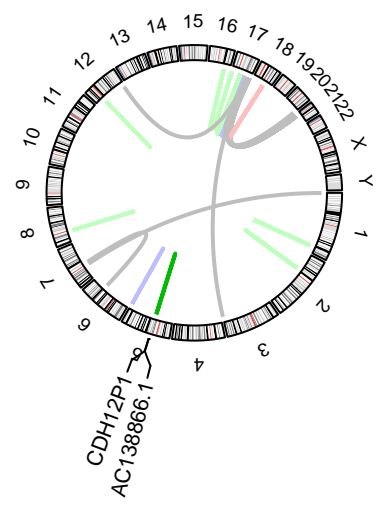
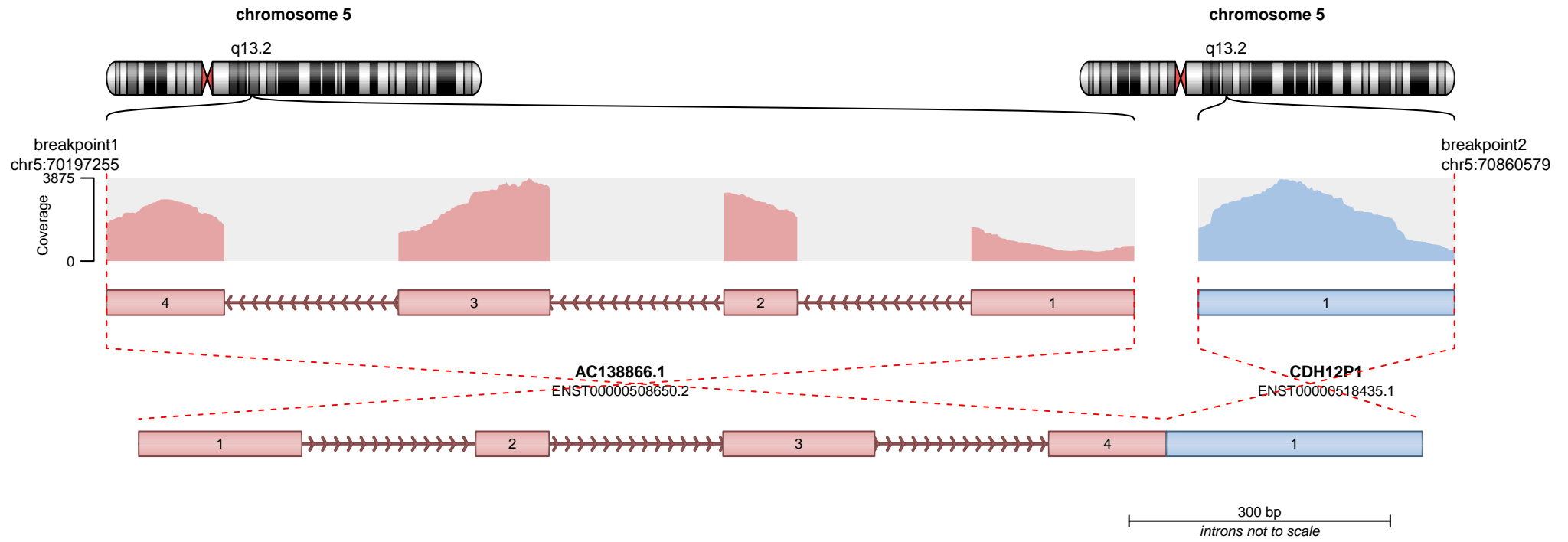

— translocation — deletion
— duplication — inversion

Genes are not protein-coding.

SUPPORTING READ COUNT

Split reads = 11
Discordant mates = 0

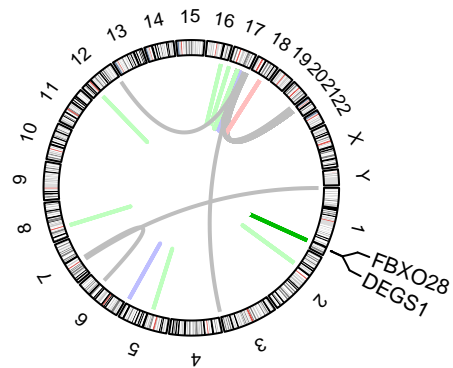
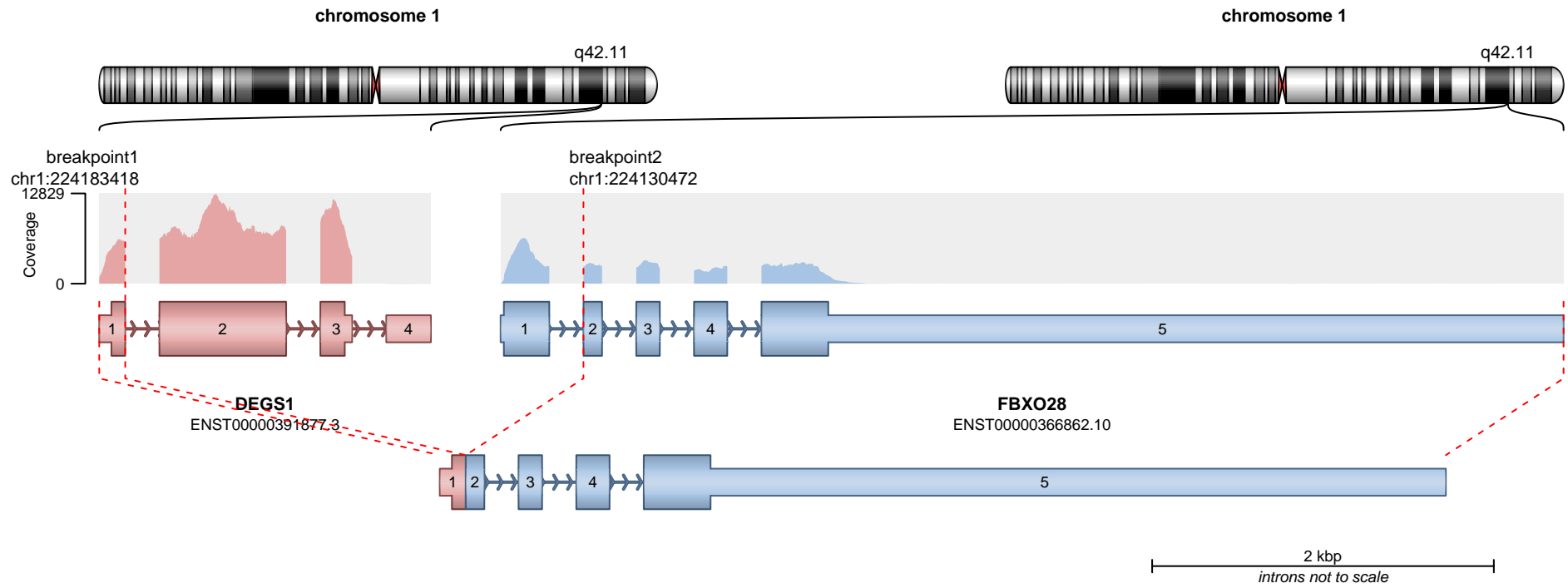

RETAINED PROTEIN DOMAINS
reading frame unclear

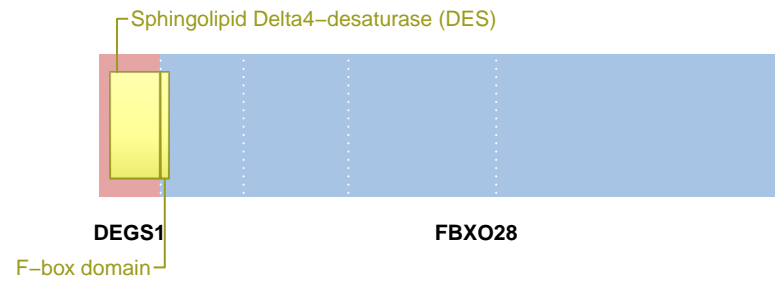

SUPPORTING READ COUNT

Split reads = 8
Discordant mates = 0

— translocation — deletion
— duplication — inversion

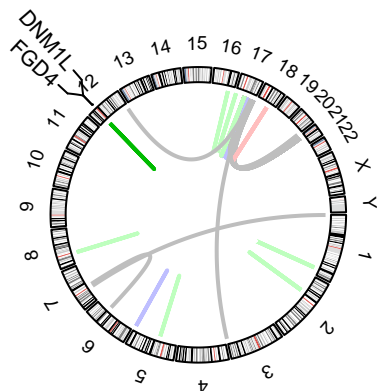
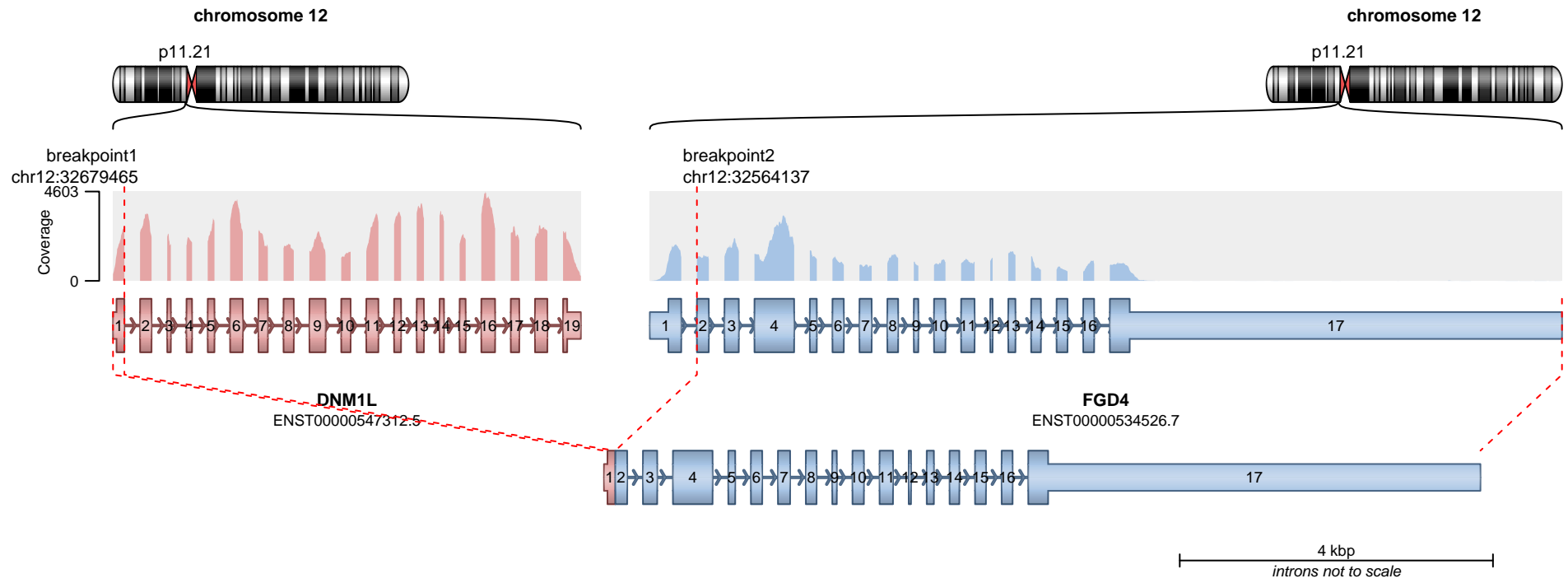

— translocation — deletion
— duplication — inversion

RETAINED PROTEIN DOMAINS
reading frame unclear

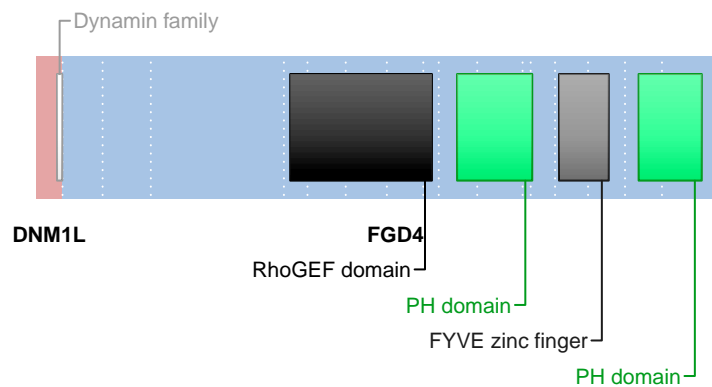

SUPPORTING READ COUNT

Split reads = 9
Discordant mates = 0