

RETAINED PROTEIN DOMAINS
reading frame unclear

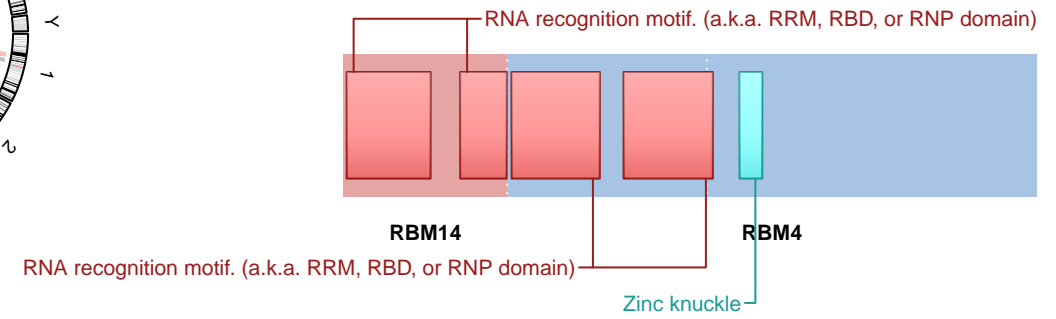

SUPPORTING READ COUNT

Split reads = 880
Discordant mates = 3

- translocation
- duplication
- deletion
- inversion

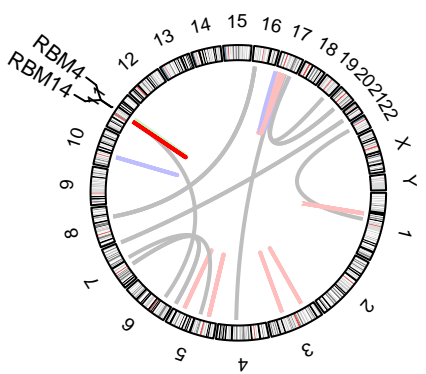
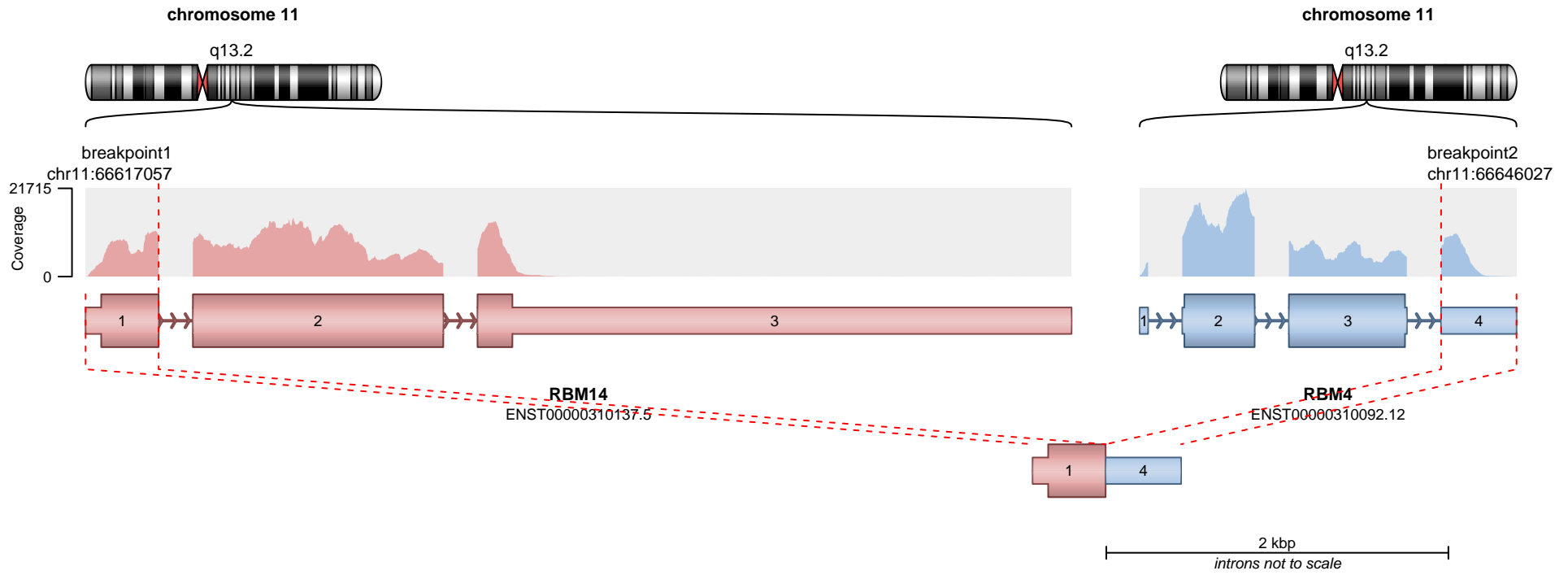

RETAINED PROTEIN DOMAINS
reading frame unclear

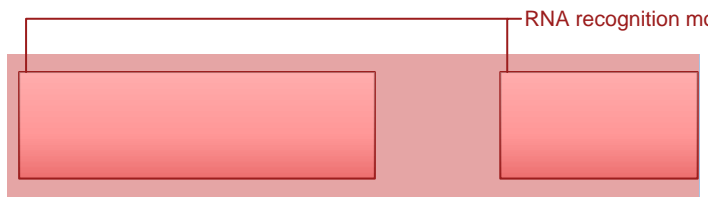

RBM14

SUPPORTING READ COUNT

Split reads = 98
Discordant mates = 0

— translocation — deletion
— duplication — inversion

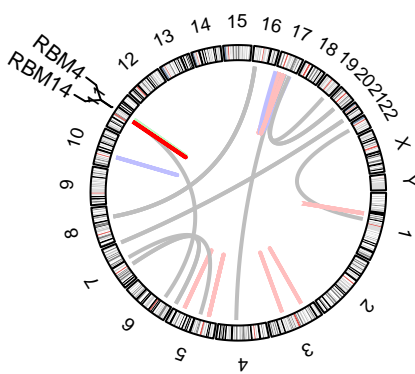
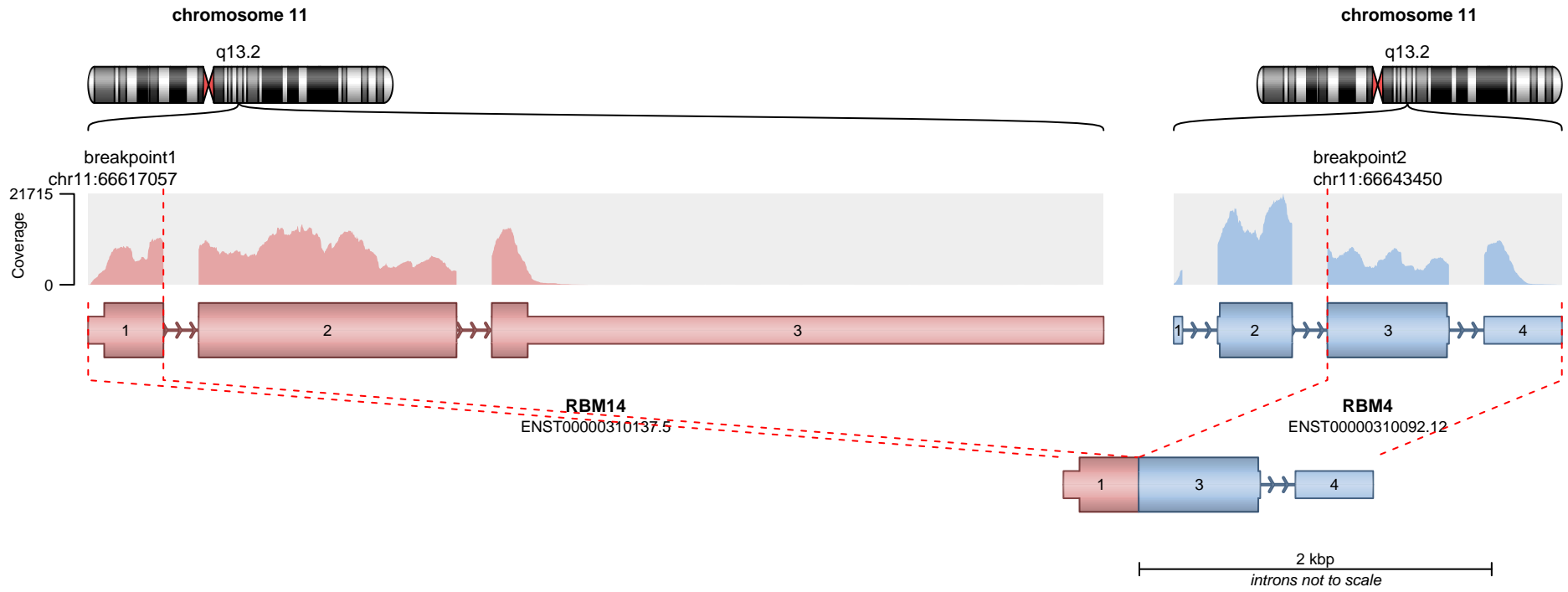

RETAINED PROTEIN DOMAINS
reading frame unclear

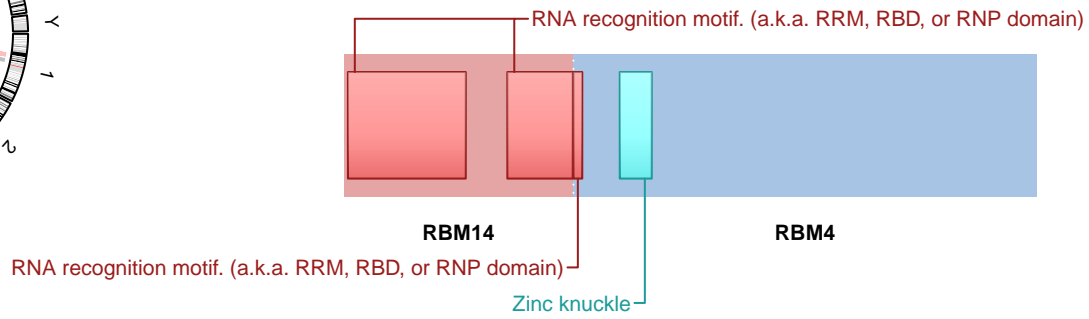

SUPPORTING READ COUNT

Split reads = 23
Discordant mates = 0

- translocation
- duplication
- deletion
- inversion

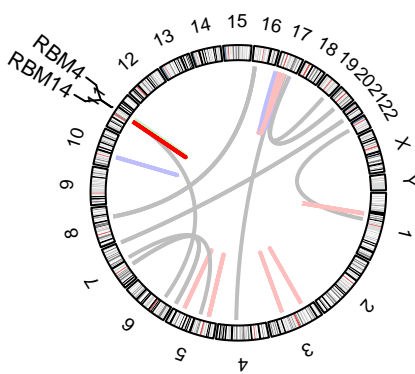
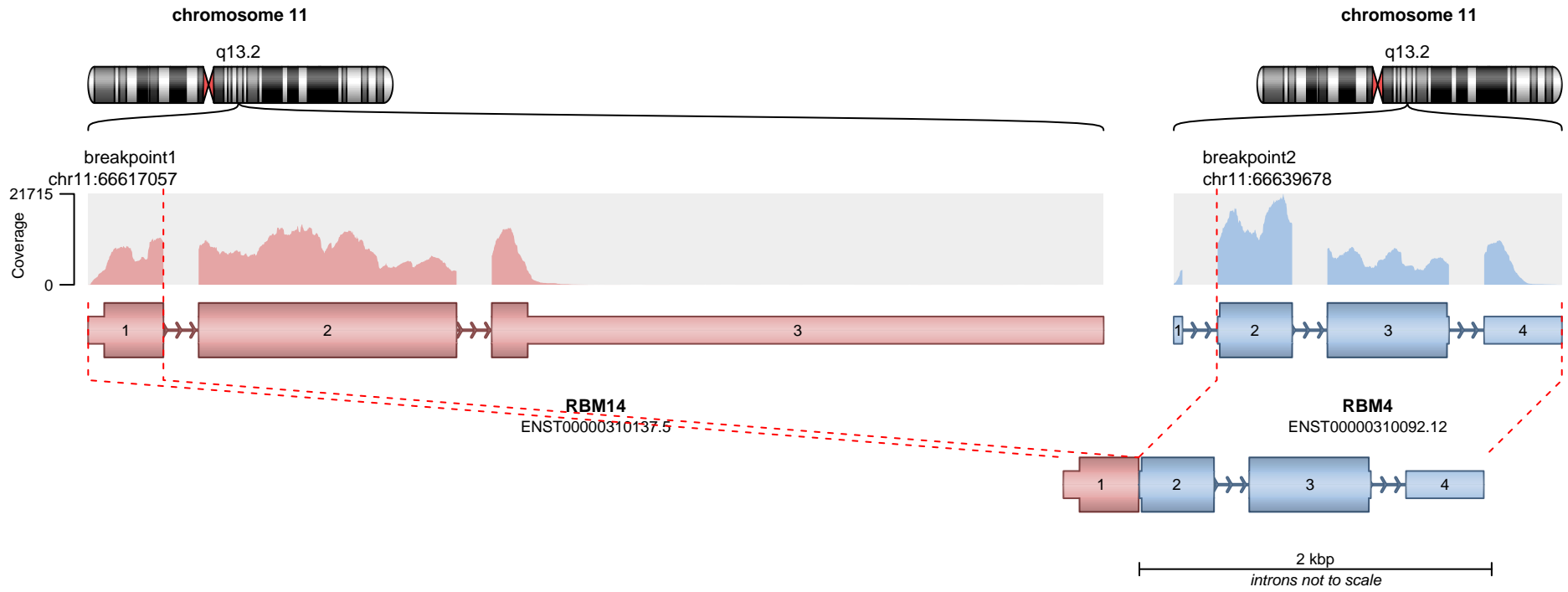

RETAINED PROTEIN DOMAINS
reading frame unclear

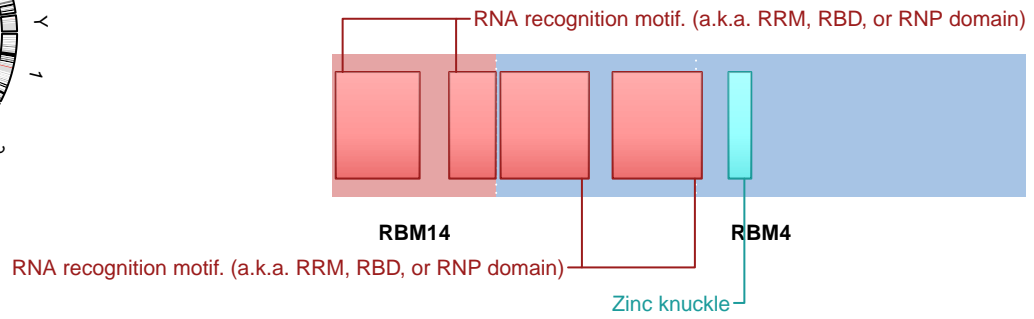

SUPPORTING READ COUNT

Split reads = 16
Discordant mates = 4

- translocation
- duplication
- deletion
- inversion

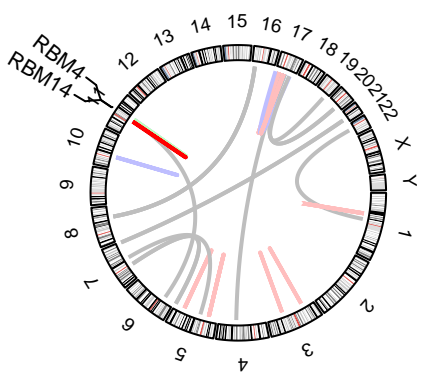
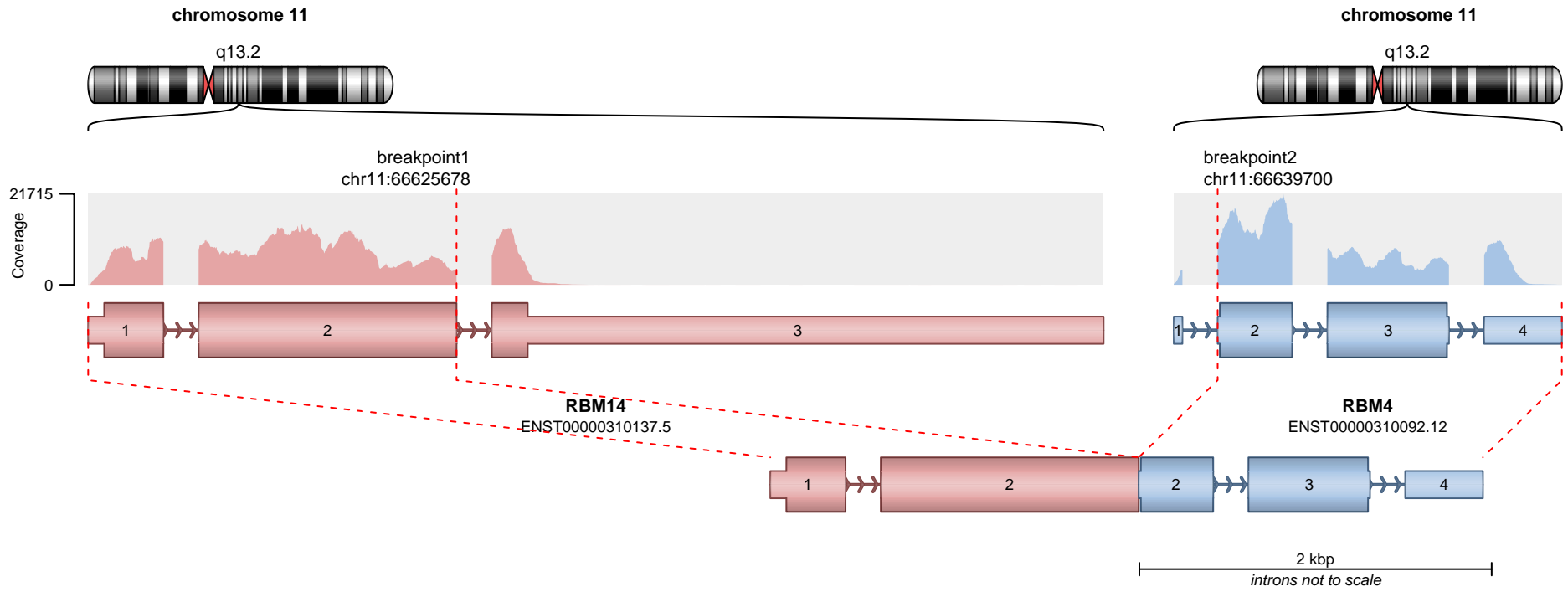

RETAINED PROTEIN DOMAINS
reading frame unclear

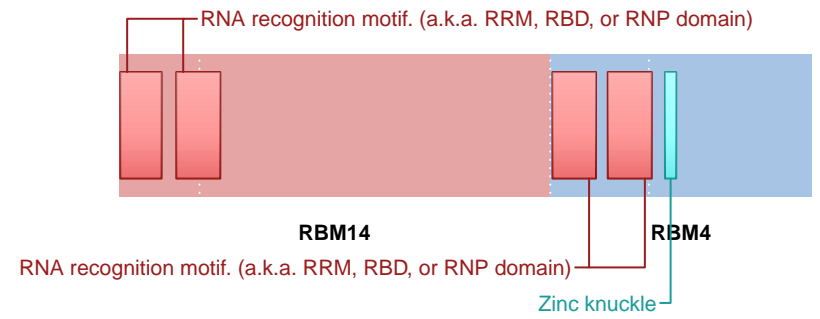

SUPPORTING READ COUNT

Split reads = 3
Discordant mates = 3

- translocation
- duplication
- deletion
- inversion

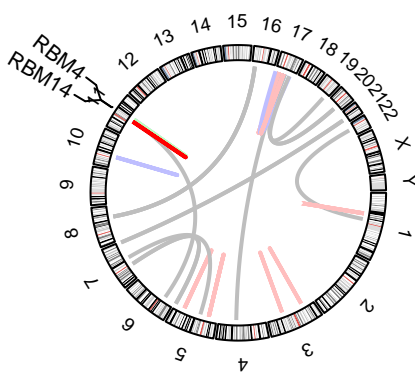
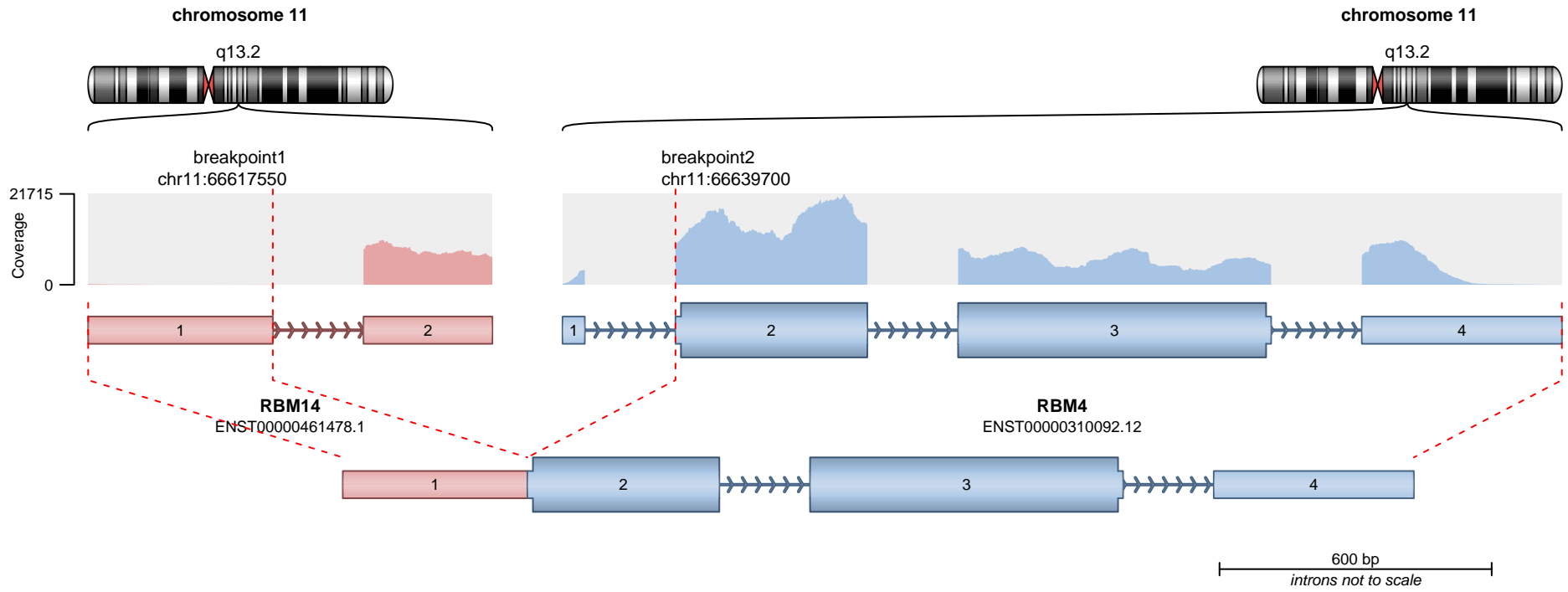

RNA recognition motif. (a.k.a. RRM, RBD, or RNP domain)

RETAINED PROTEIN DOMAINS
reading frame unclear

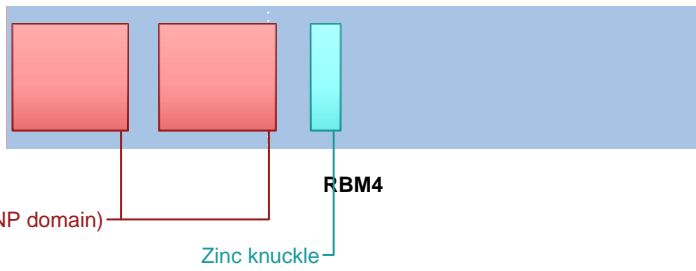

SUPPORTING READ COUNT

Split reads = 2
Discordant mates = 3

- translocation
- duplication
- deletion
- inversion

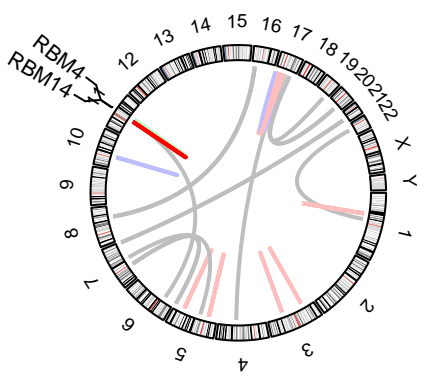
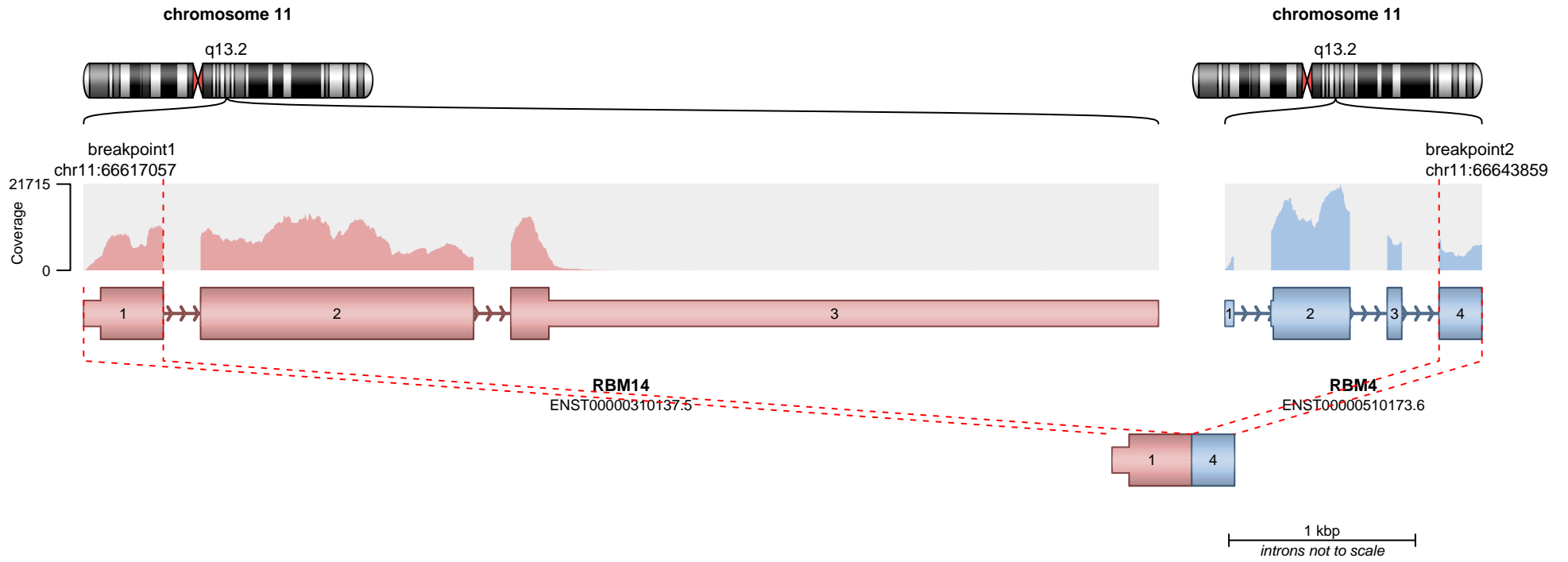

RETAINED PROTEIN DOMAINS
reading frame unclear

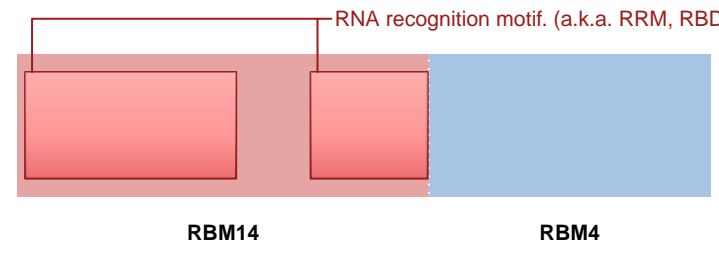

SUPPORTING READ COUNT

Split reads = 1
Discordant mates = 0

- translocation
- duplication
- deletion
- inversion

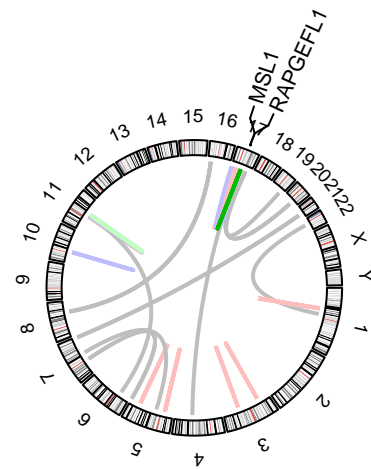
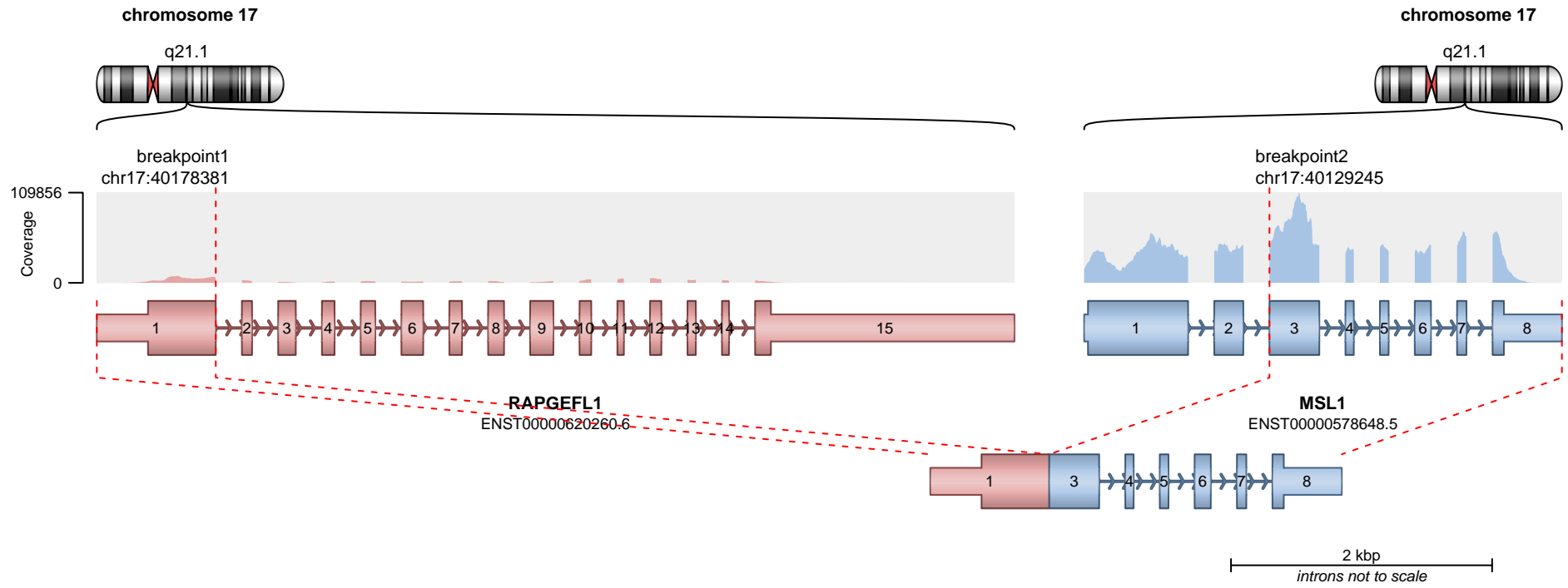

RETAINED PROTEIN DOMAINS
reading frame unclear

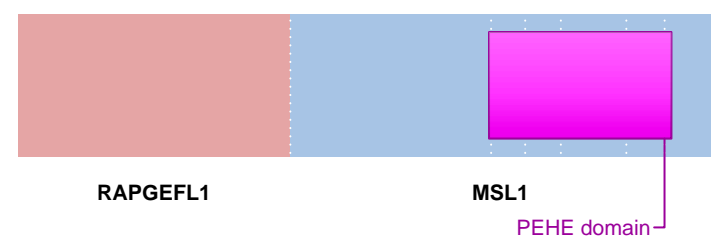

SUPPORTING READ COUNT

Split reads = 818
Discordant mates = 6

— translocation — deletion
— duplication — inversion

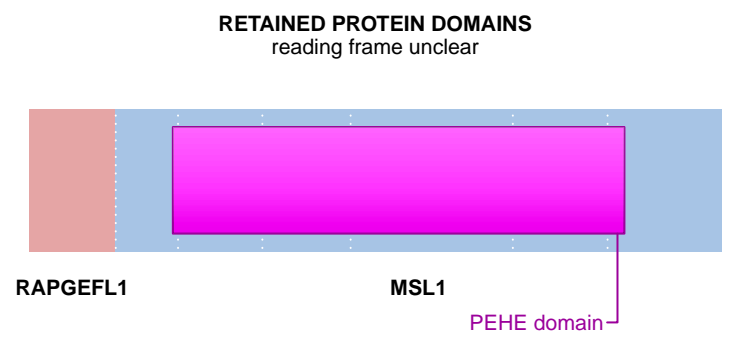
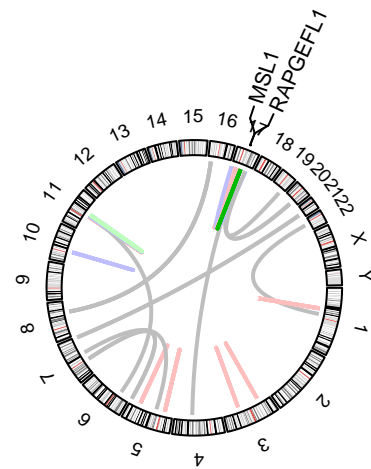
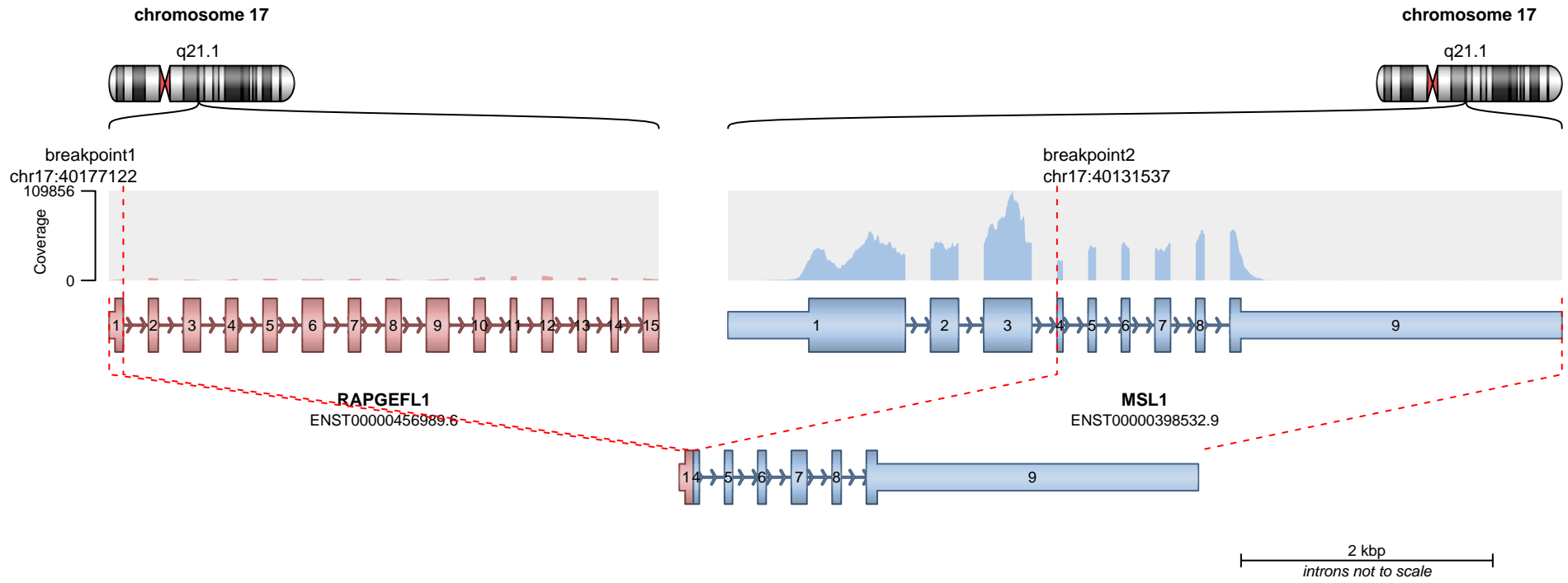

SUPPORTING READ COUNT

Split reads = 4
Discordant mates = 0

— translocation — deletion
— duplication — inversion

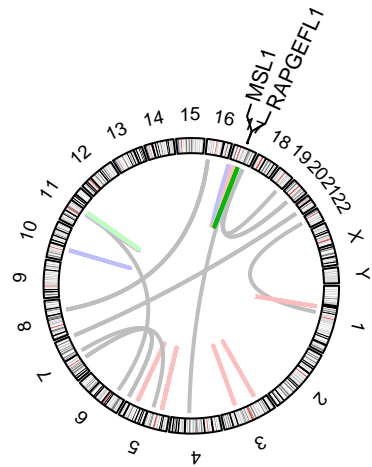

RETAINED PROTEIN DOMAINS
reading frame unclear

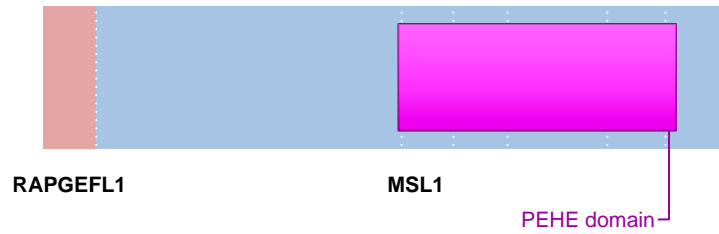

SUPPORTING READ COUNT

Split reads = 2
Discordant mates = 0

— translocation — deletion
— duplication — inversion

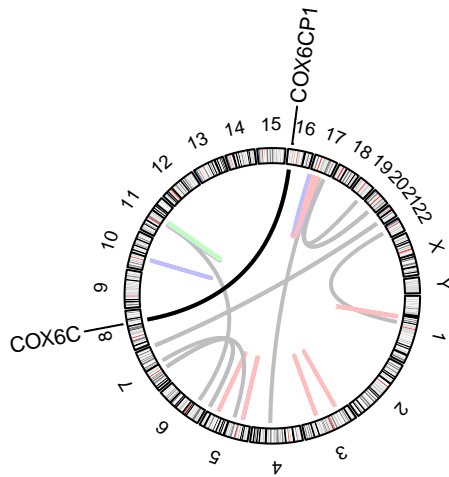
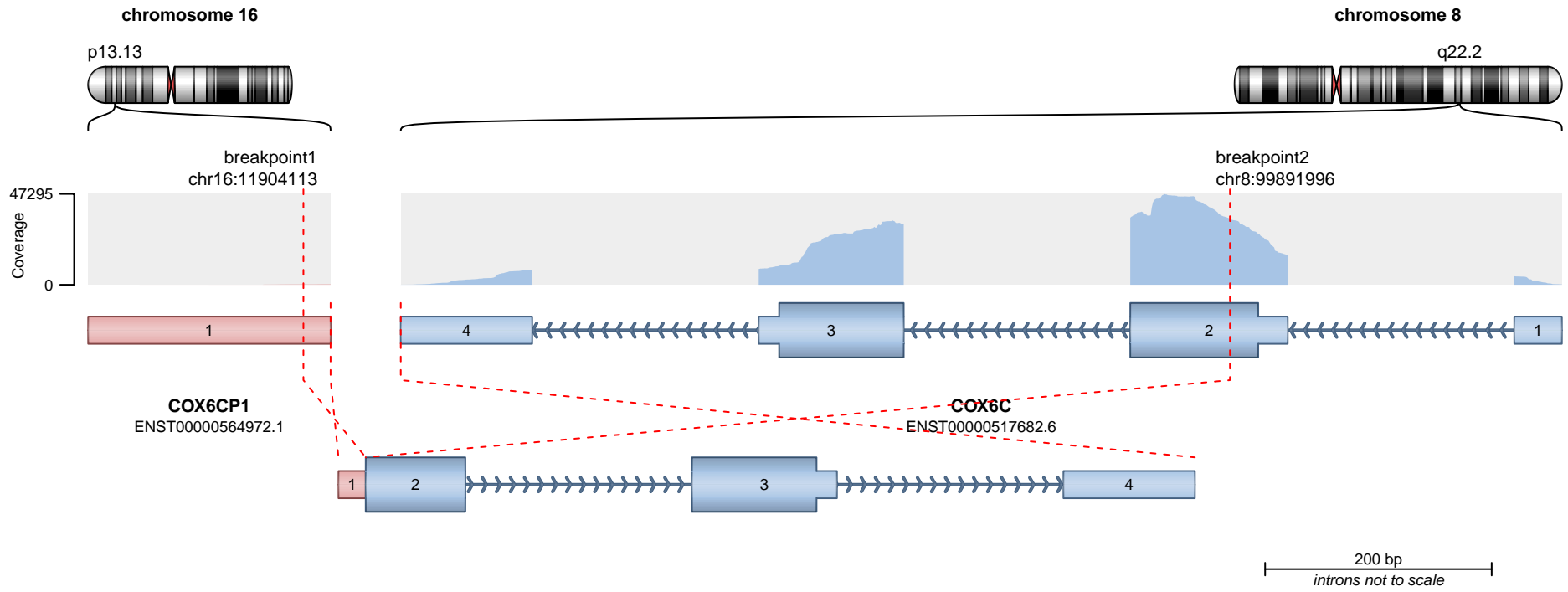

RETAINED PROTEIN DOMAINS
reading frame unclear



COX6C
Cytochrome c oxidase subunit VIc

SUPPORTING READ COUNT

Split reads = 310
Discordant mates = 0

— translocation — deletion
— duplication — inversion

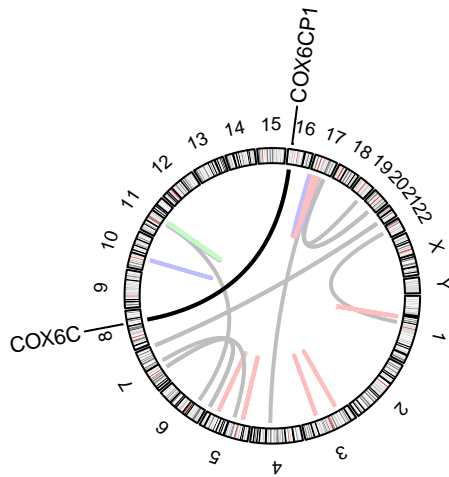
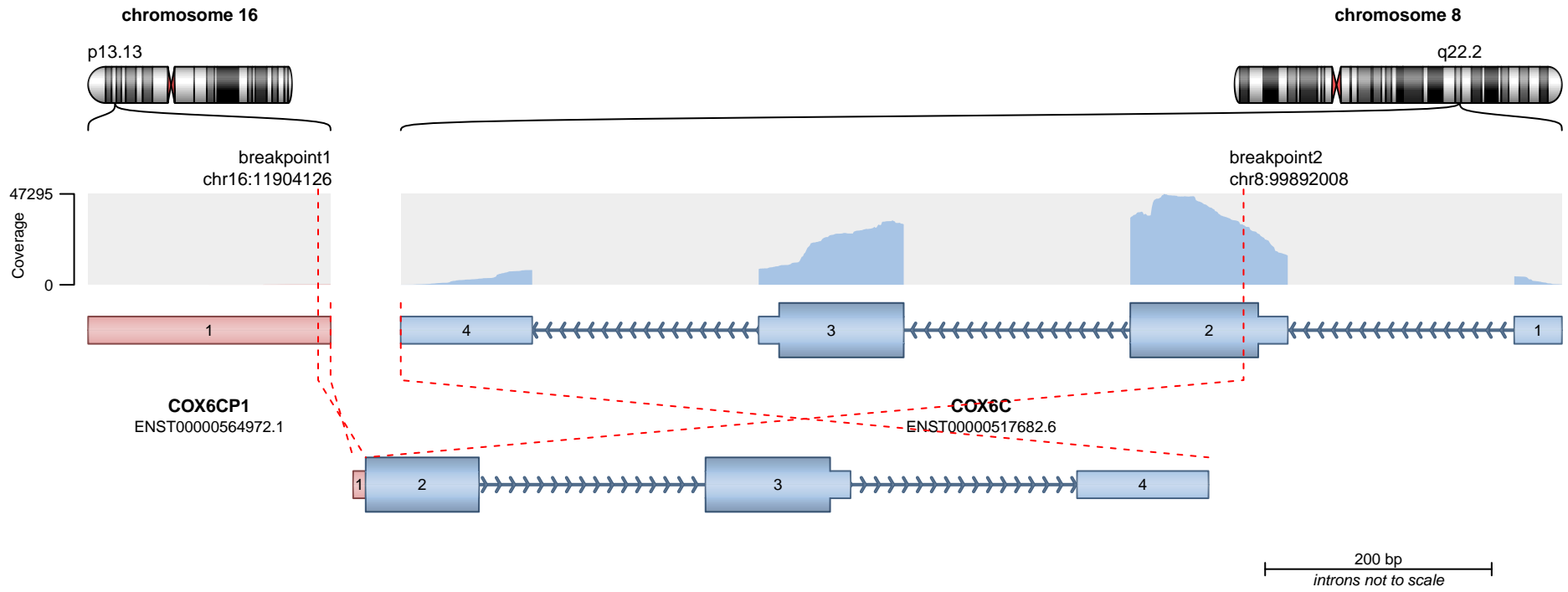

RETAINED PROTEIN DOMAINS
reading frame unclear



COX6C
Cytochrome c oxidase subunit VIc

SUPPORTING READ COUNT

Split reads = 29
Discordant mates = 0

— translocation — deletion
— duplication — inversion

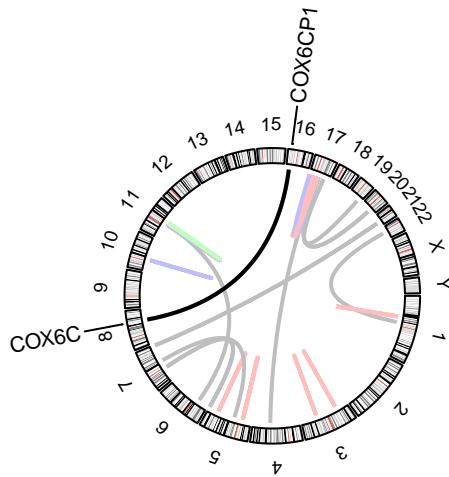
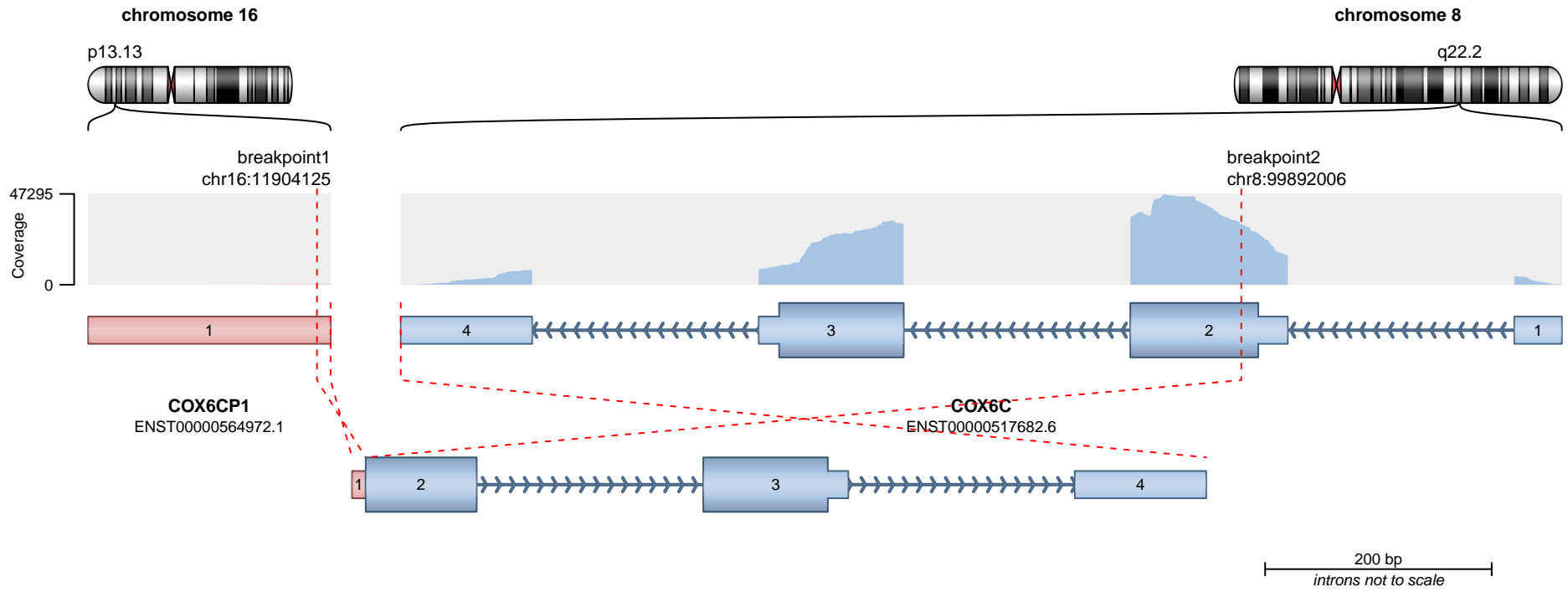

RETAINED PROTEIN DOMAINS
reading frame unclear

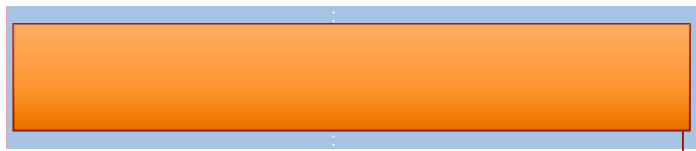

COX6C
Cytochrome c oxidase subunit VIc

SUPPORTING READ COUNT

Split reads = 12
Discordant mates = 0

— translocation — deletion
— duplication — inversion

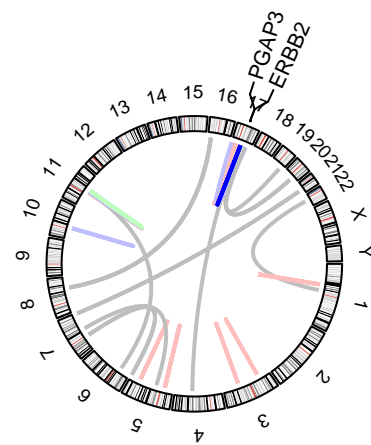
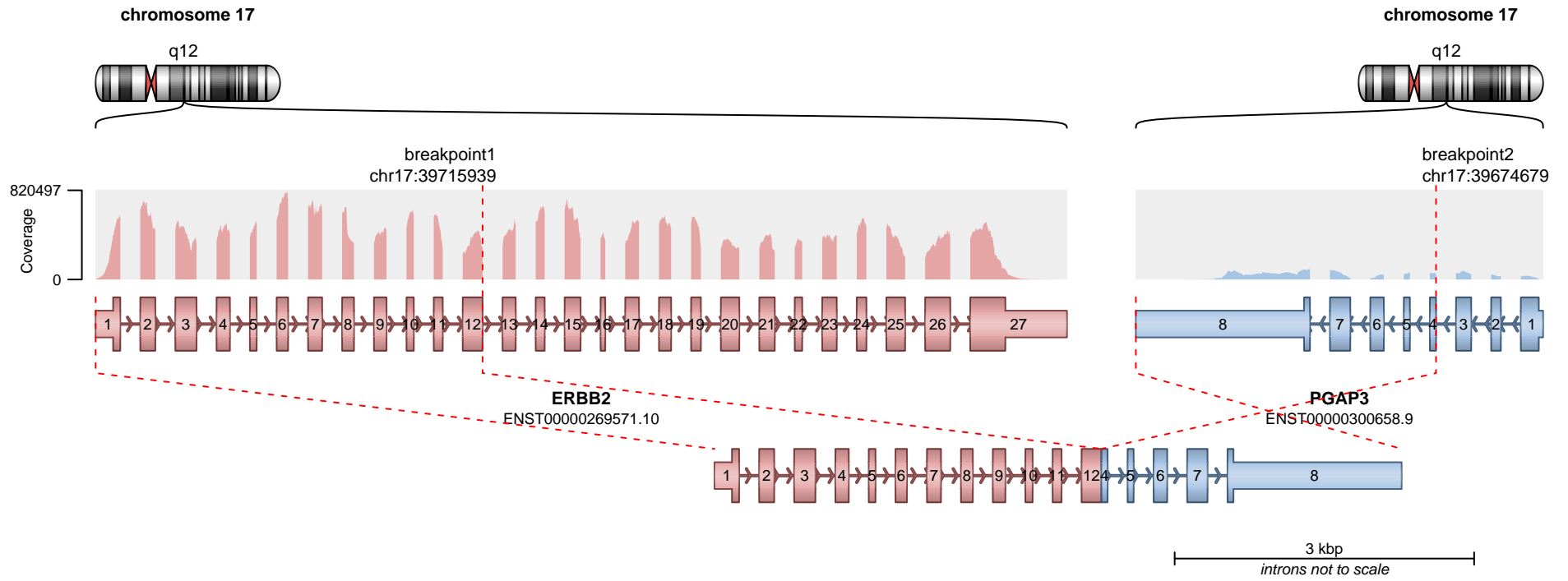

RETAINED PROTEIN DOMAINS
reading frame unclear

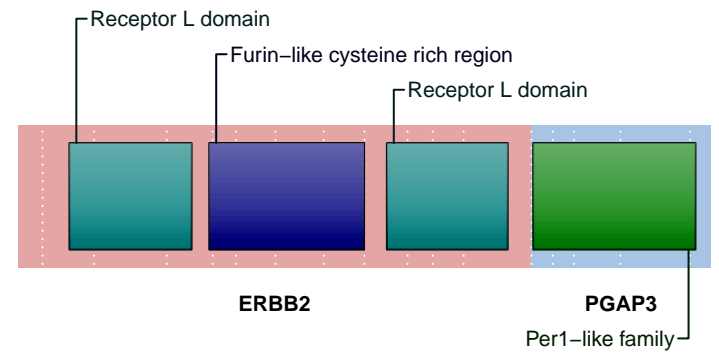

SUPPORTING READ COUNT

Split reads = 307
Discordant mates = 2

— translocation — deletion
— duplication — inversion

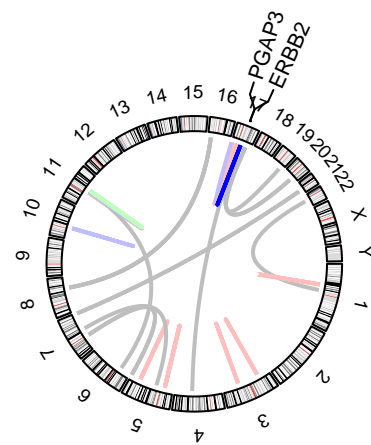
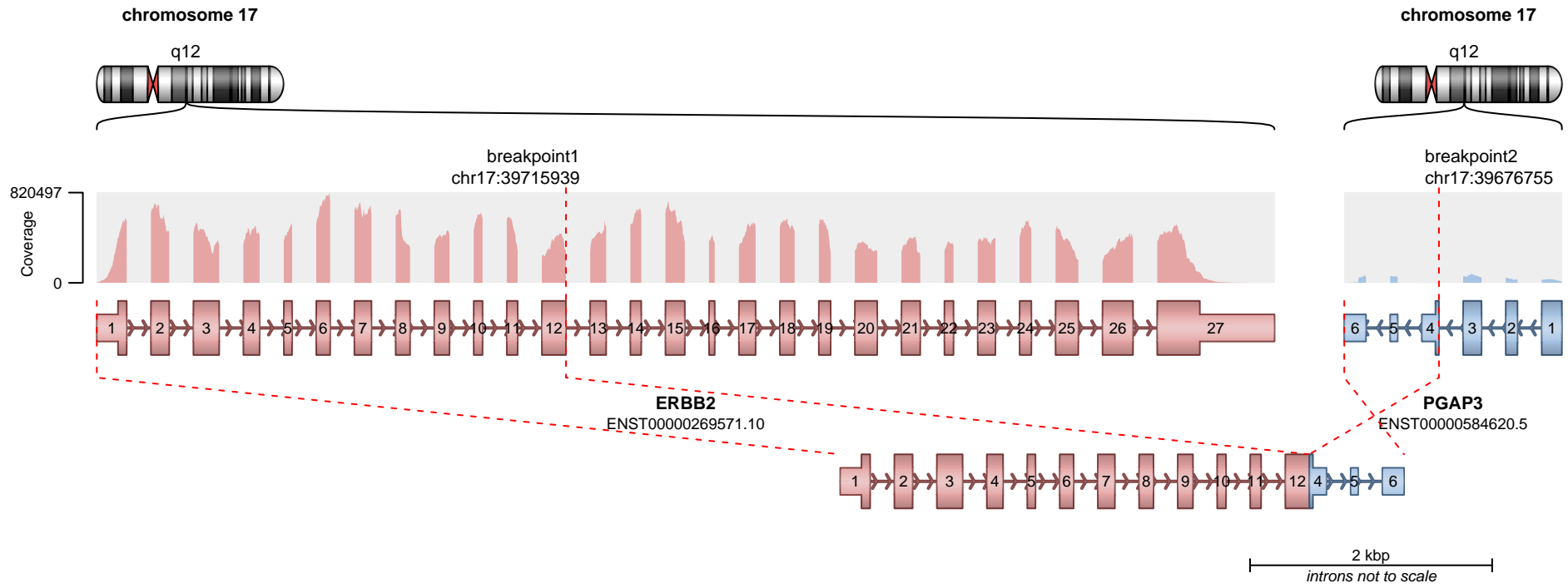

RETAINED PROTEIN DOMAINS
reading frame unclear

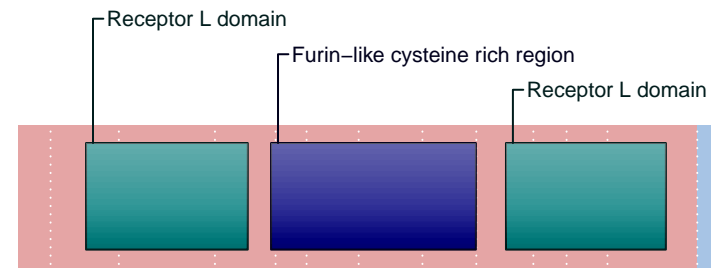

SUPPORTING READ COUNT

Split reads = 100
Discordant mates = 2

- translocation
- duplication
- deletion
- inversion

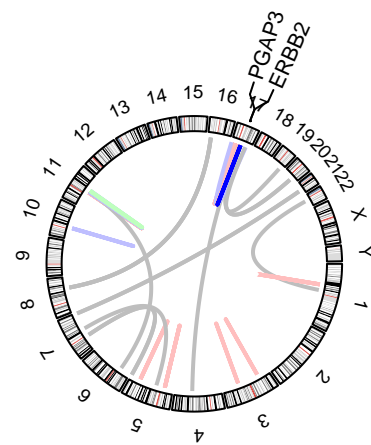
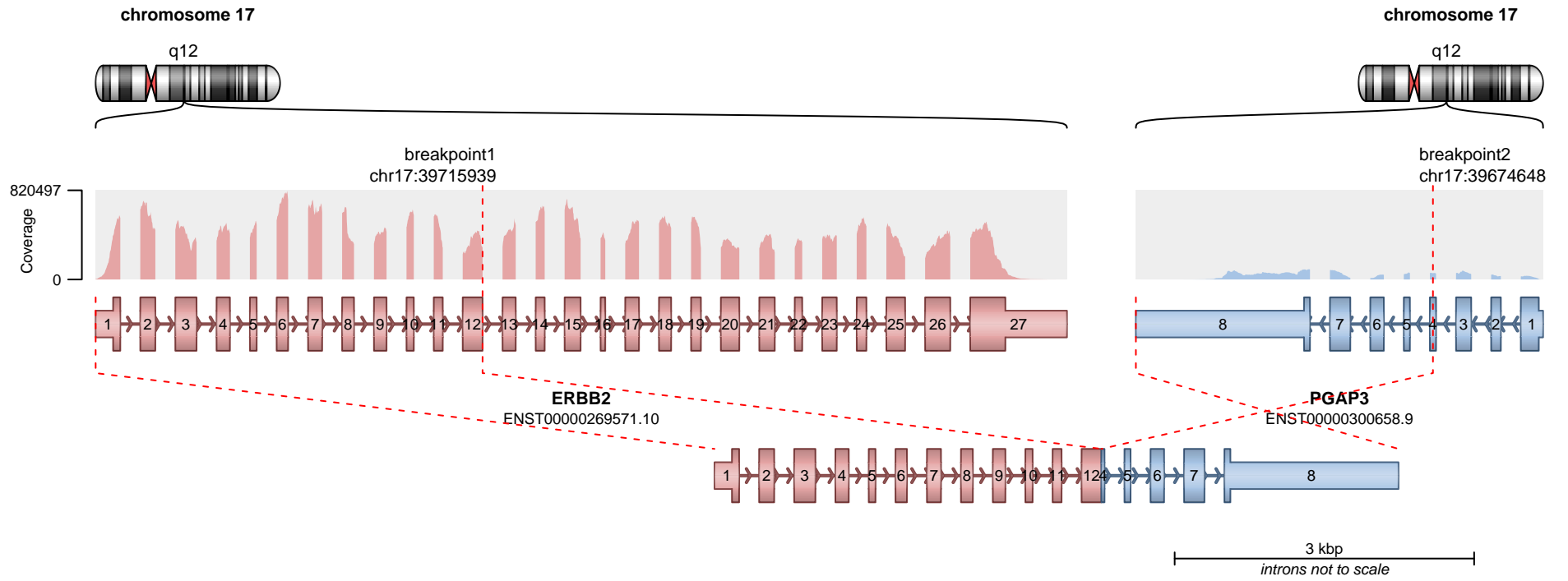

RETAINED PROTEIN DOMAINS
reading frame unclear

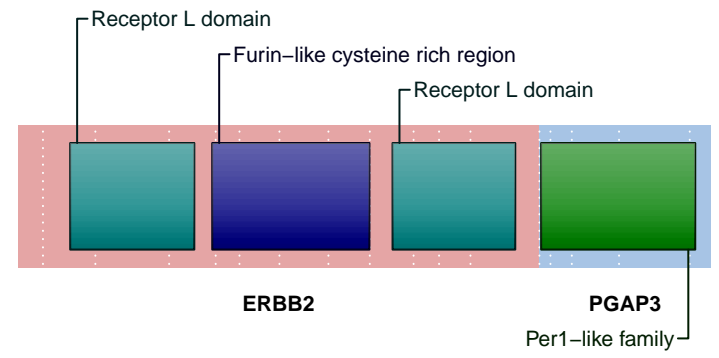

SUPPORTING READ COUNT

Split reads = 11
Discordant mates = 0

— translocation — deletion
— duplication — inversion

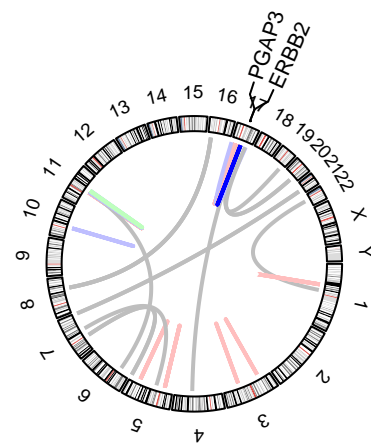
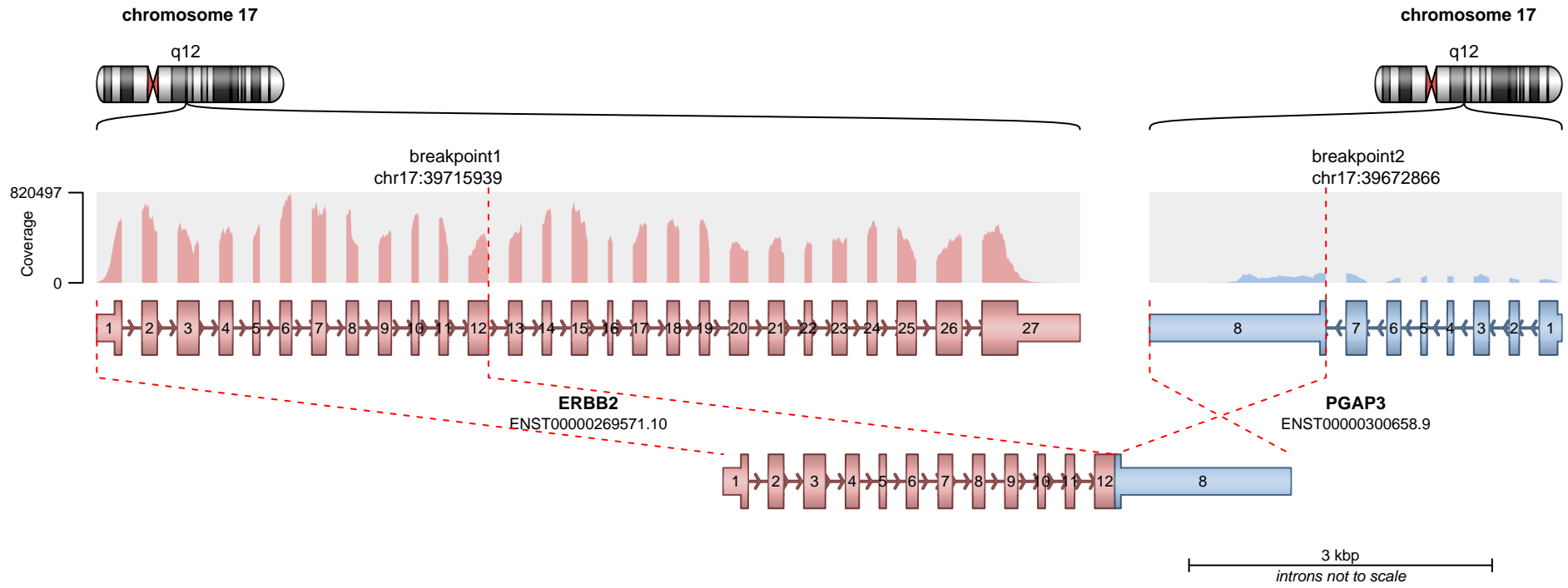

RETAINED PROTEIN DOMAINS
reading frame unclear

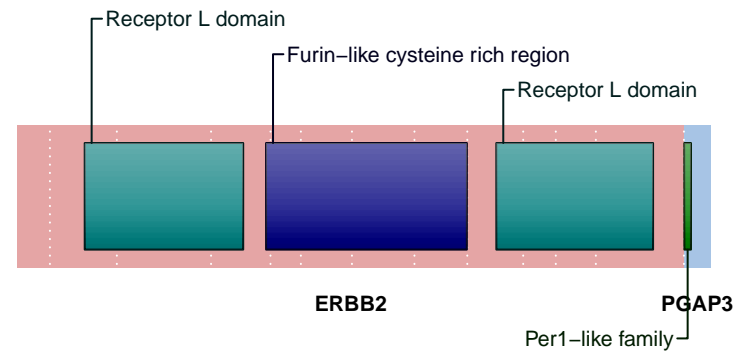

SUPPORTING READ COUNT

Split reads = 1
Discordant mates = 0

— translocation — deletion
— duplication — inversion

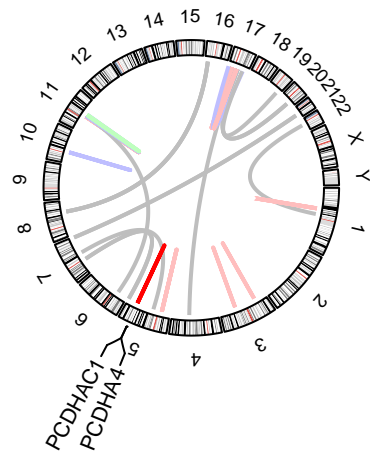
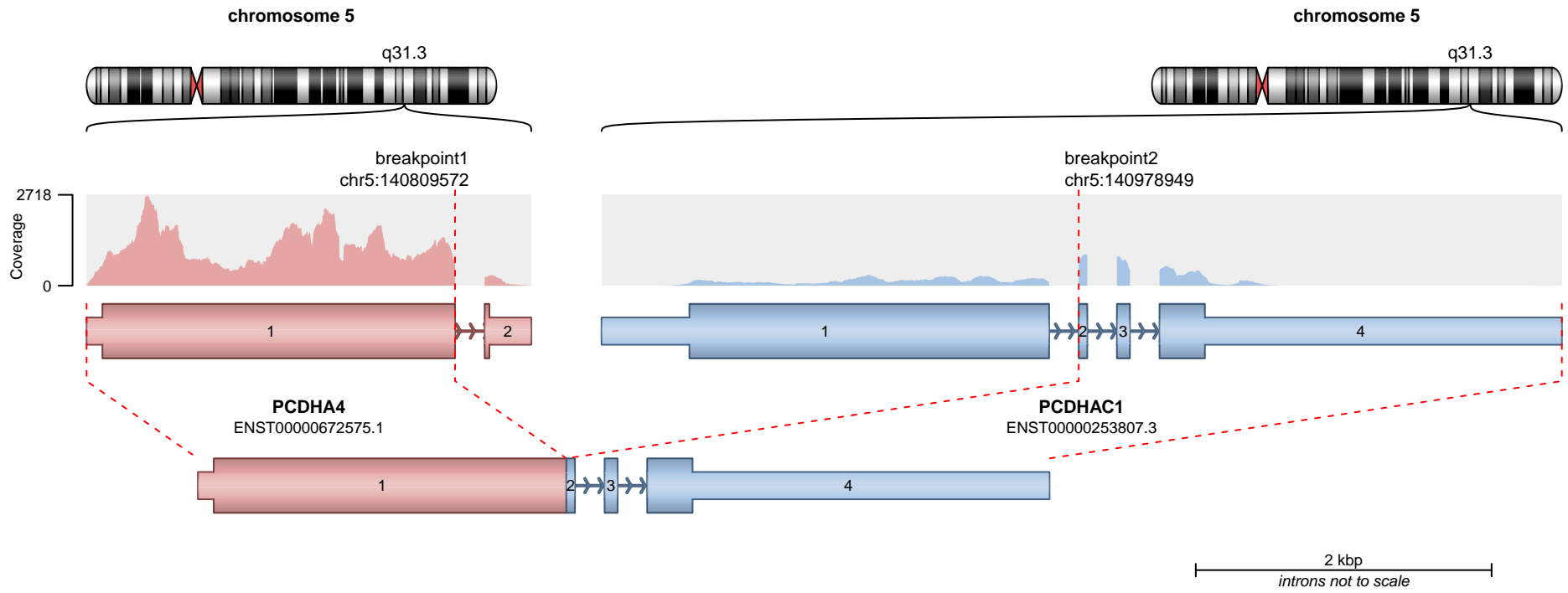

RETAINED PROTEIN DOMAINS
reading frame unclear

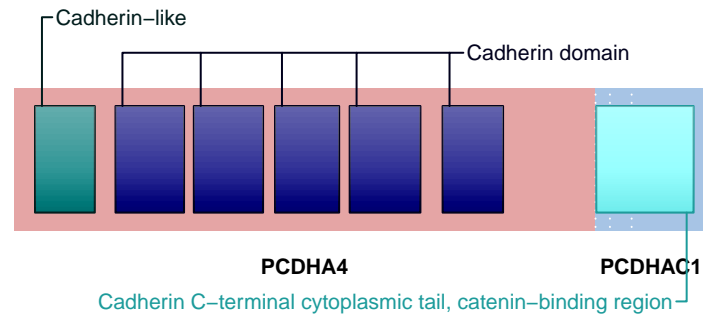

SUPPORTING READ COUNT

Split reads = 159
Discordant mates = 0

— translocation — deletion
— duplication — inversion

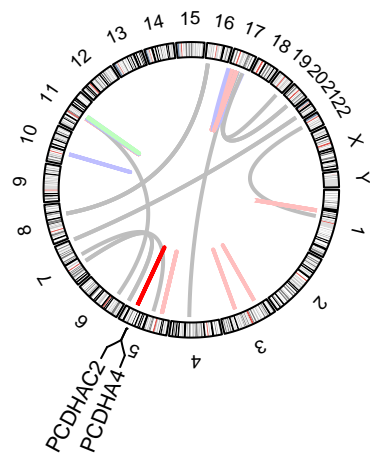
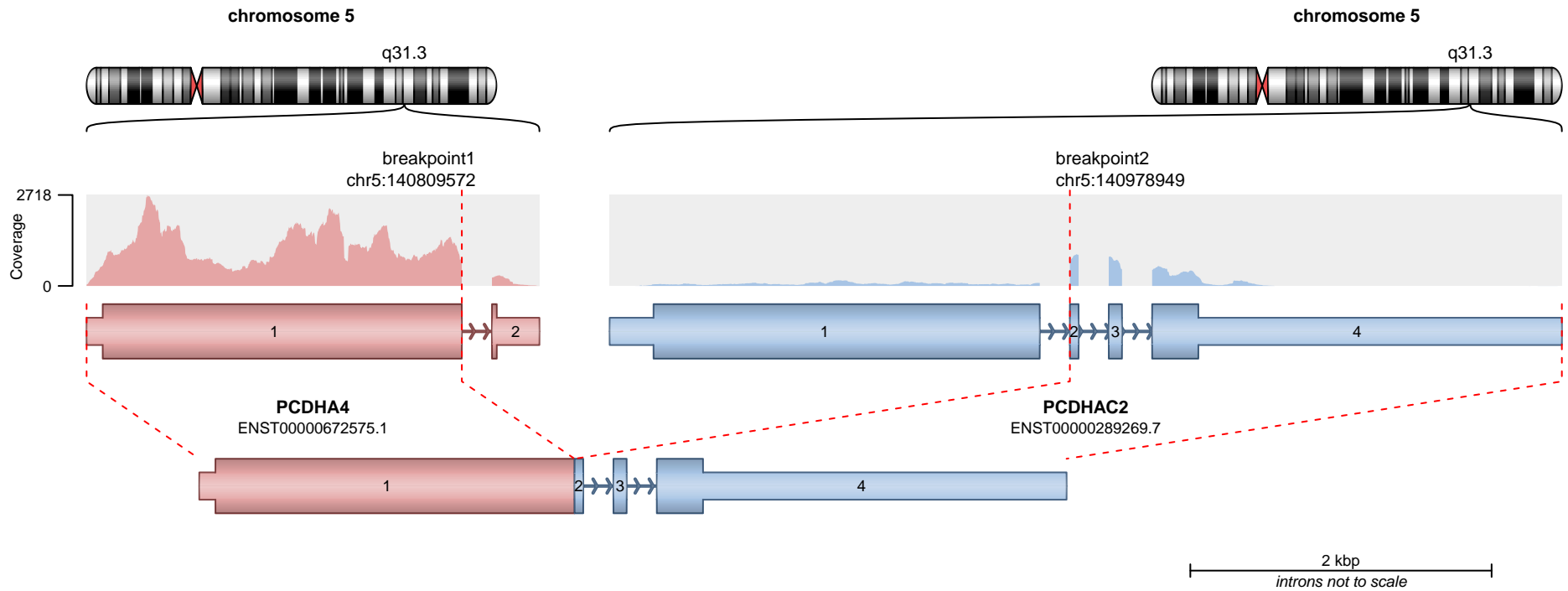

RETAINED PROTEIN DOMAINS
reading frame unclear

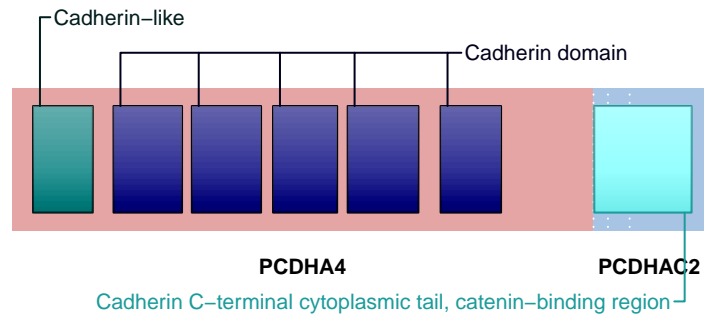

SUPPORTING READ COUNT

Split reads = 159
Discordant mates = 0

— translocation — deletion
— duplication — inversion

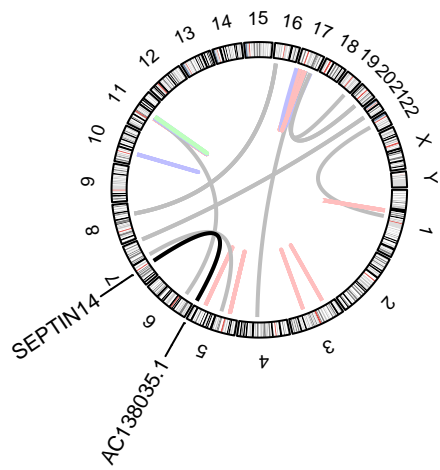
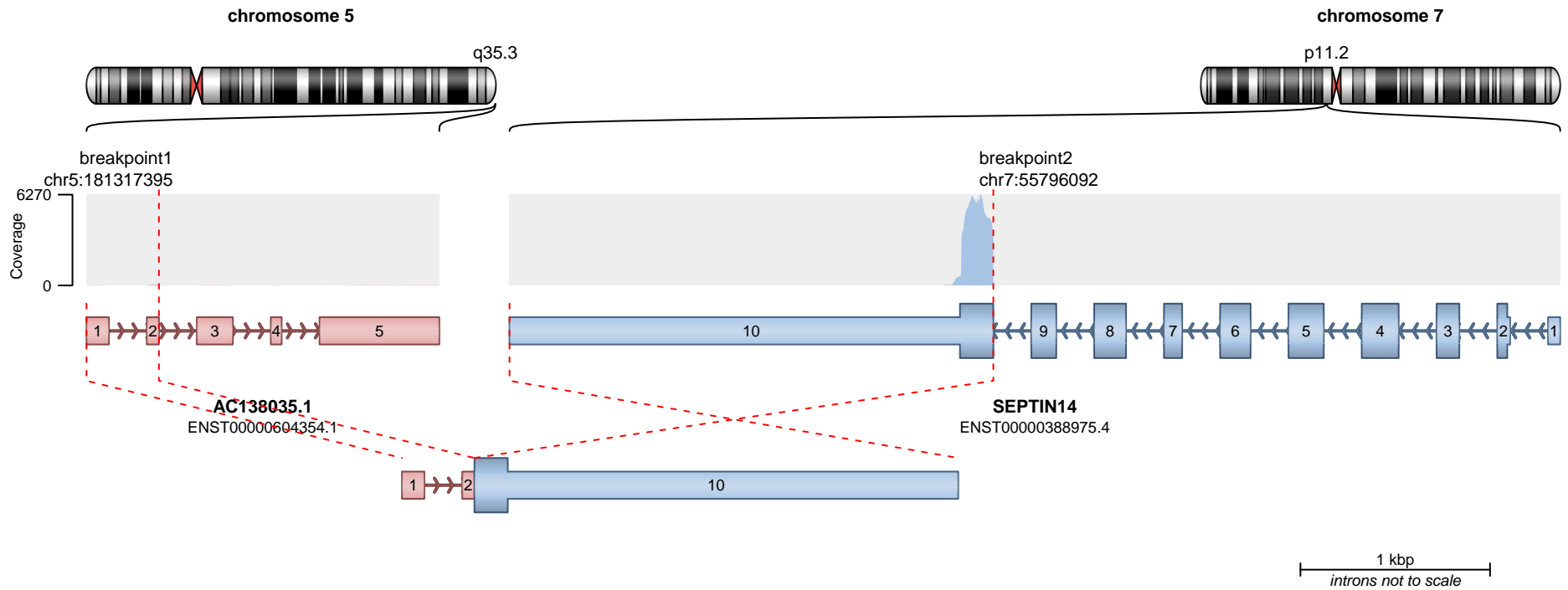

— translocation — deletion
 — duplication — inversion

No protein domains retained in fusion.

SUPPORTING READ COUNT

Split reads = 113
 Discordant mates = 0

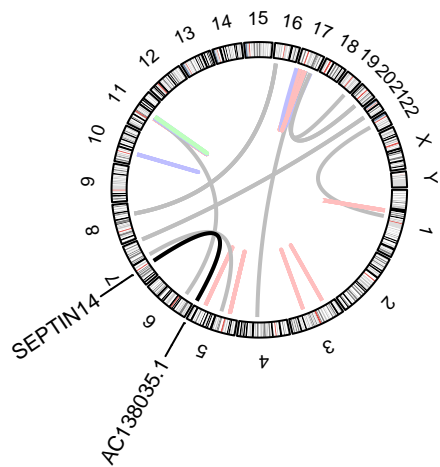
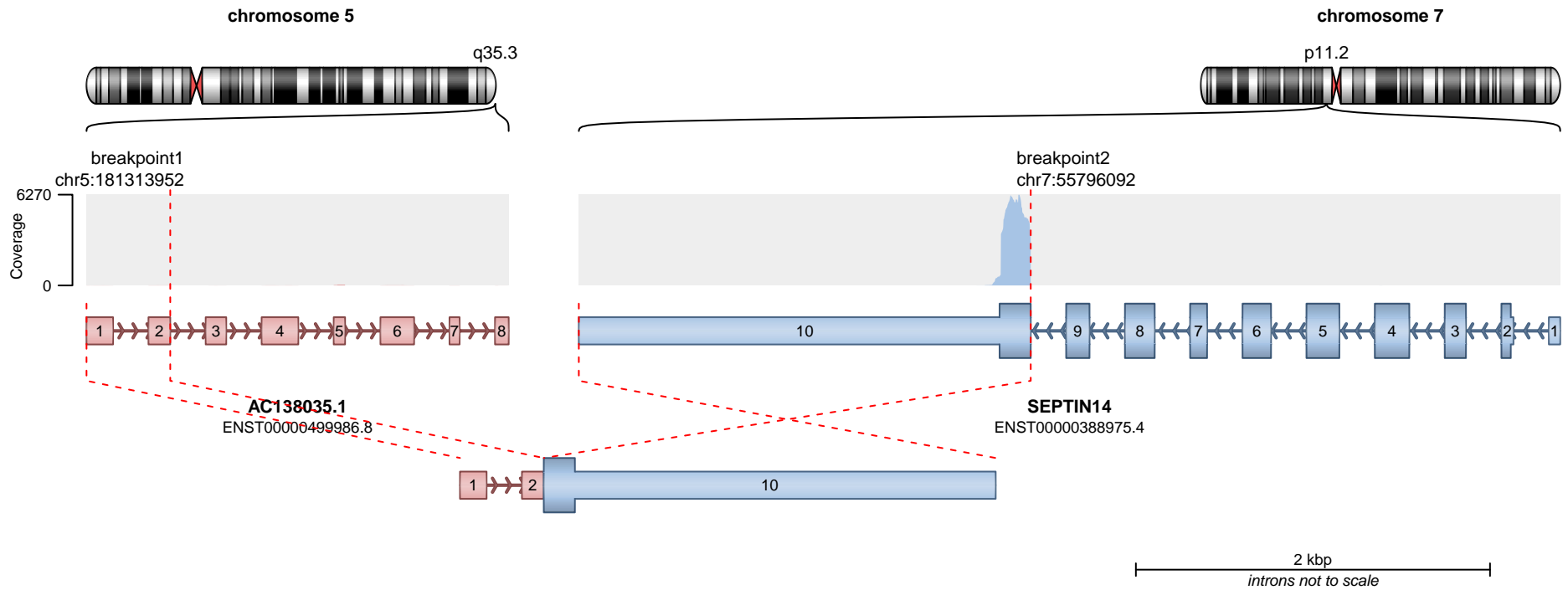

— translocation — deletion
 — duplication — inversion

No protein domains retained in fusion.

SUPPORTING READ COUNT

Split reads = 2
 Discordant mates = 0

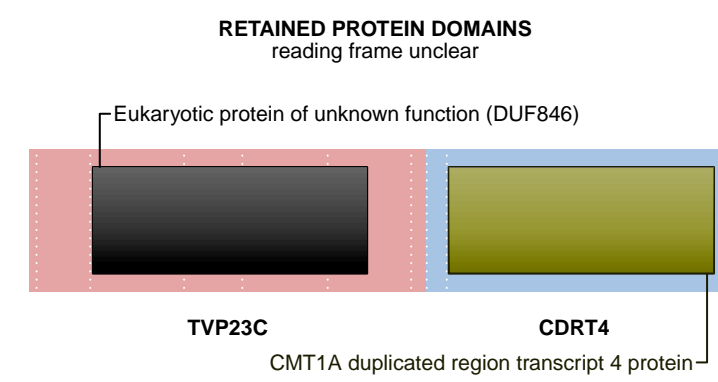
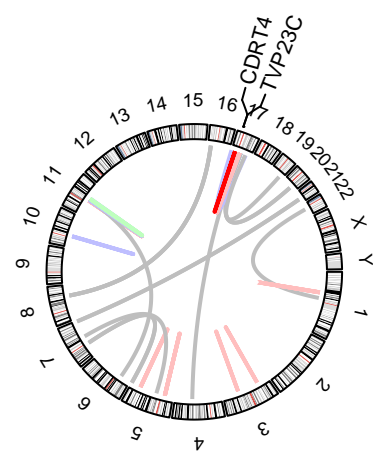
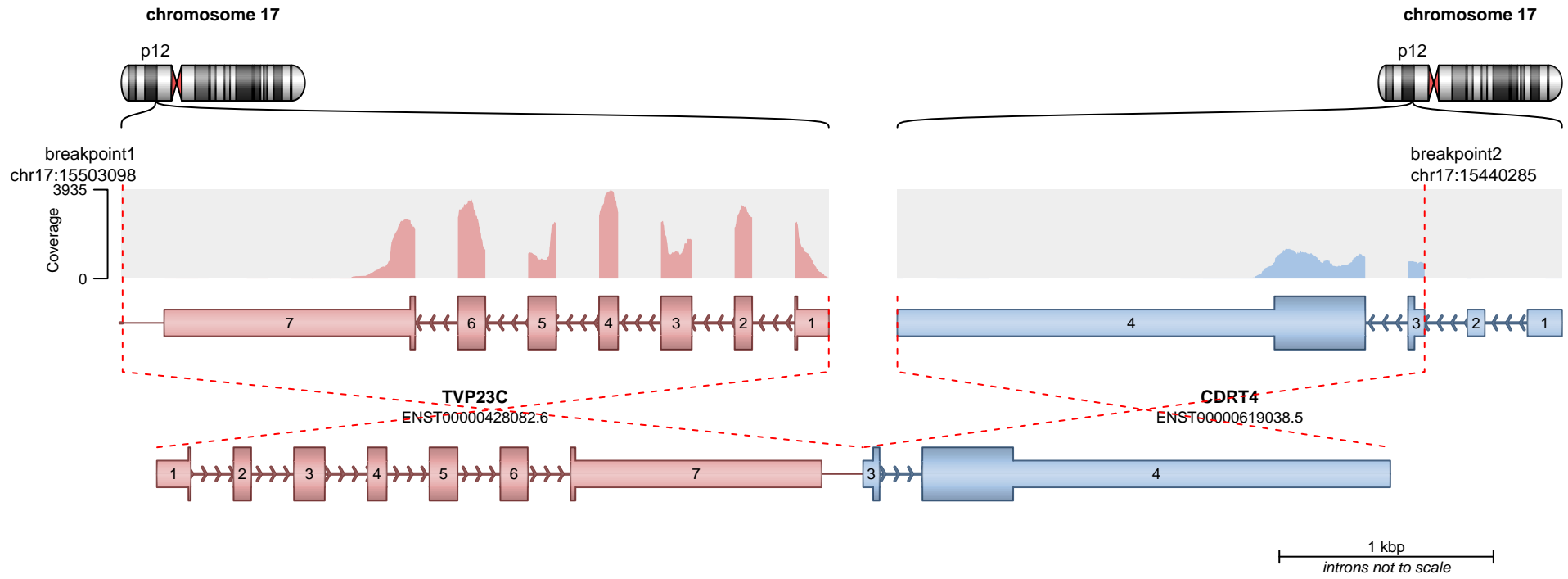

SUPPORTING READ COUNT

Split reads = 91
Discordant mates = 1

— translocation — deletion
— duplication — inversion

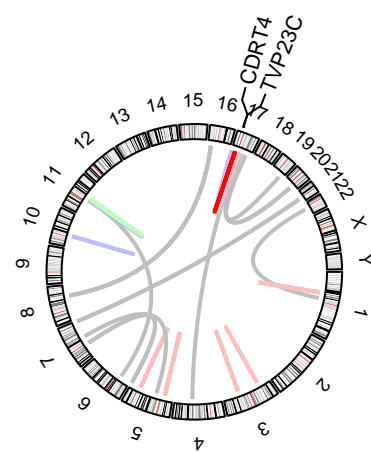
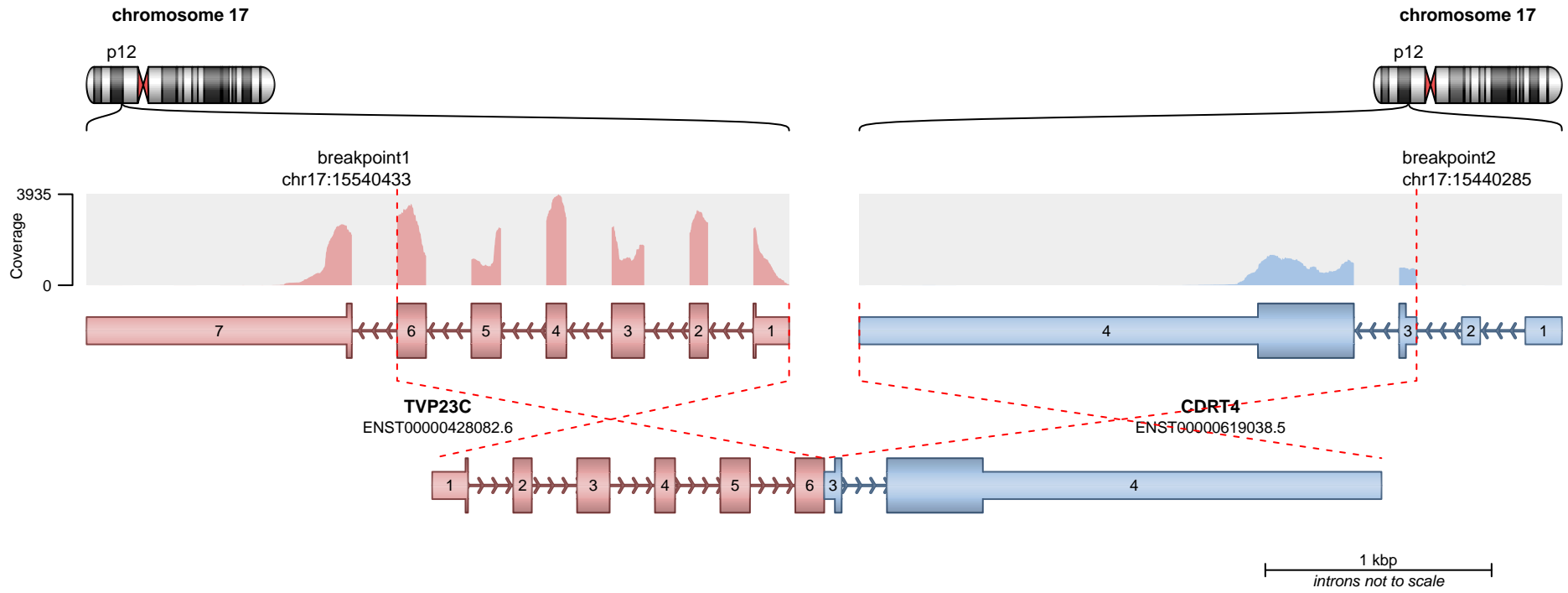

RETAINED PROTEIN DOMAINS
reading frame unclear

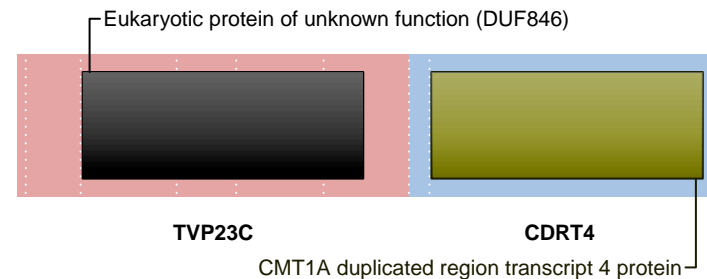

SUPPORTING READ COUNT

Split reads = 64
Discordant mates = 0

- translocation
- duplication
- deletion
- inversion

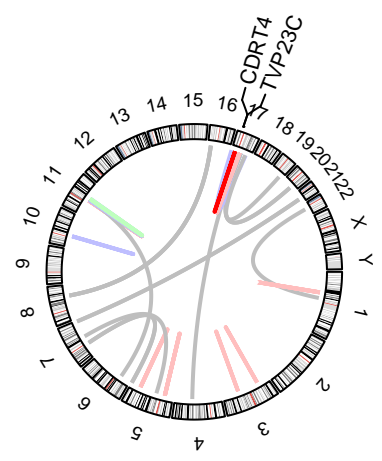
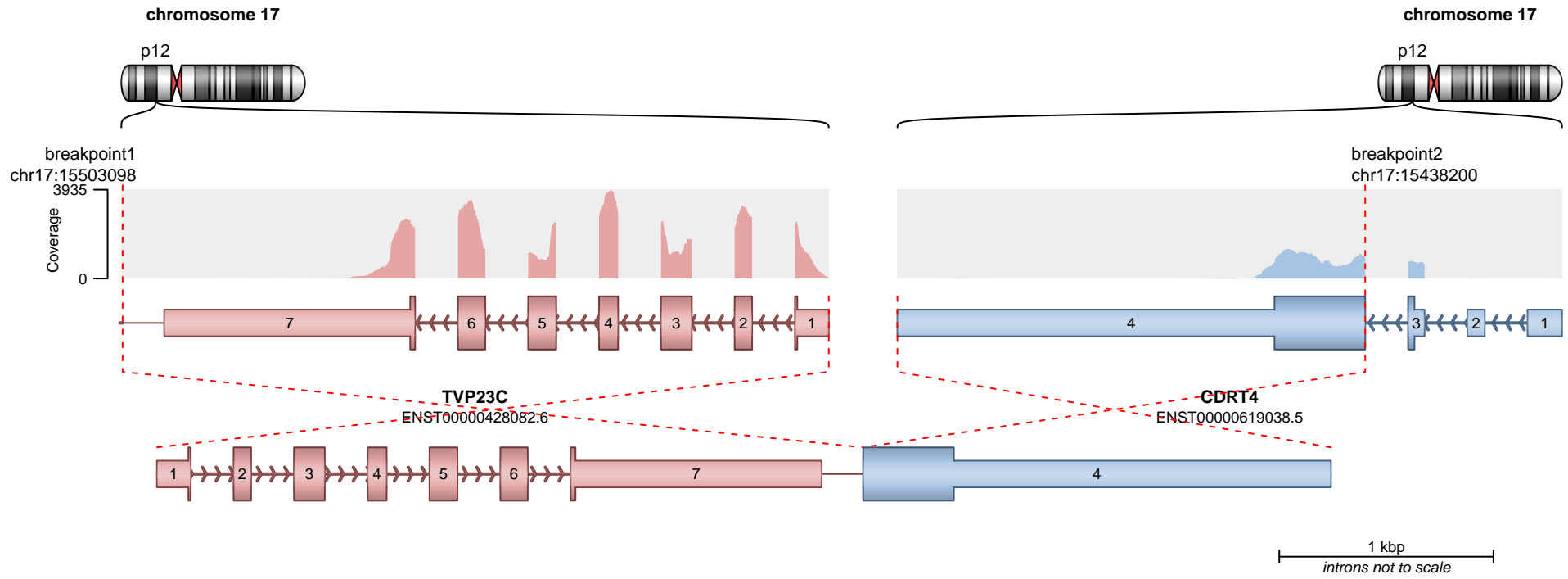

RETAINED PROTEIN DOMAINS
reading frame unclear

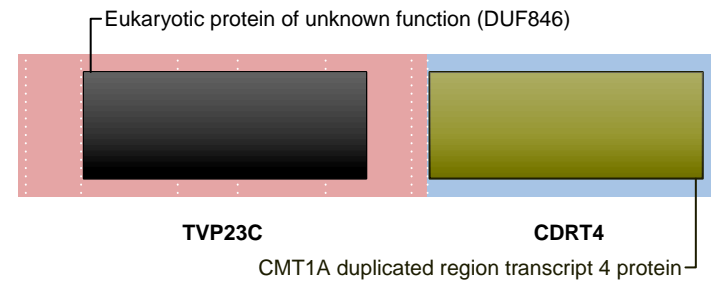

SUPPORTING READ COUNT

Split reads = 31
Discordant mates = 0

- translocation
- duplication
- deletion
- inversion

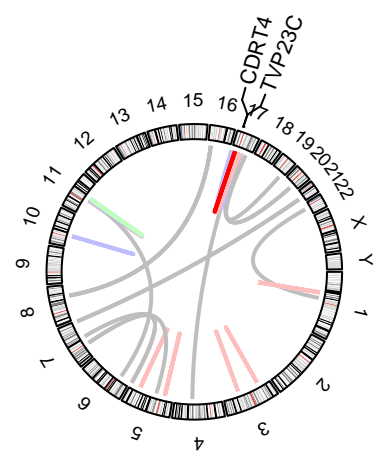
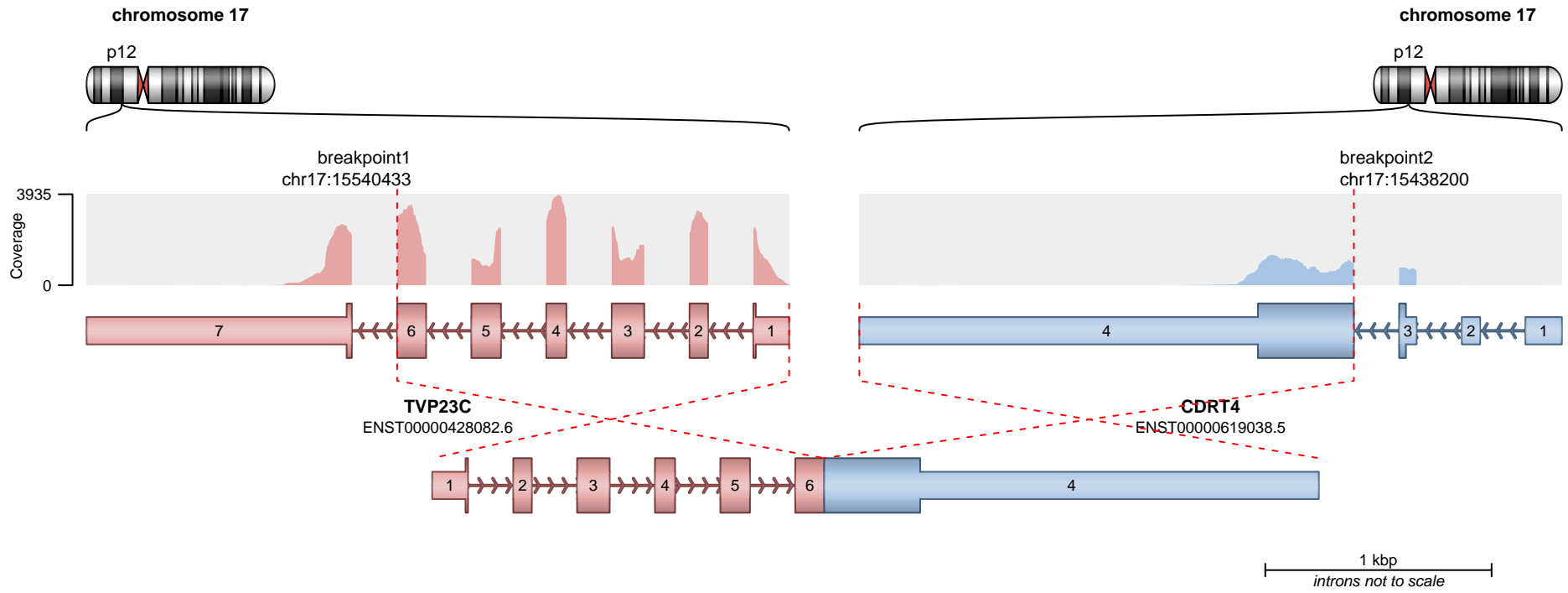

RETAINED PROTEIN DOMAINS
reading frame unclear

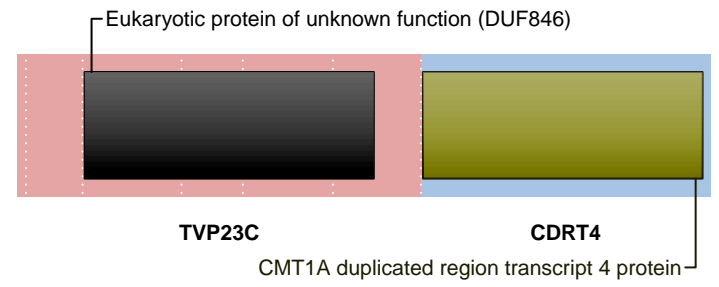

SUPPORTING READ COUNT

Split reads = 12
Discordant mates = 0

- translocation
- duplication
- deletion
- inversion

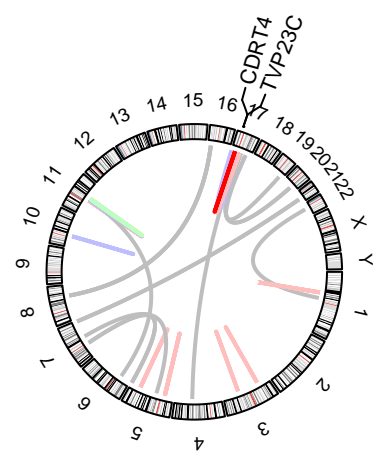
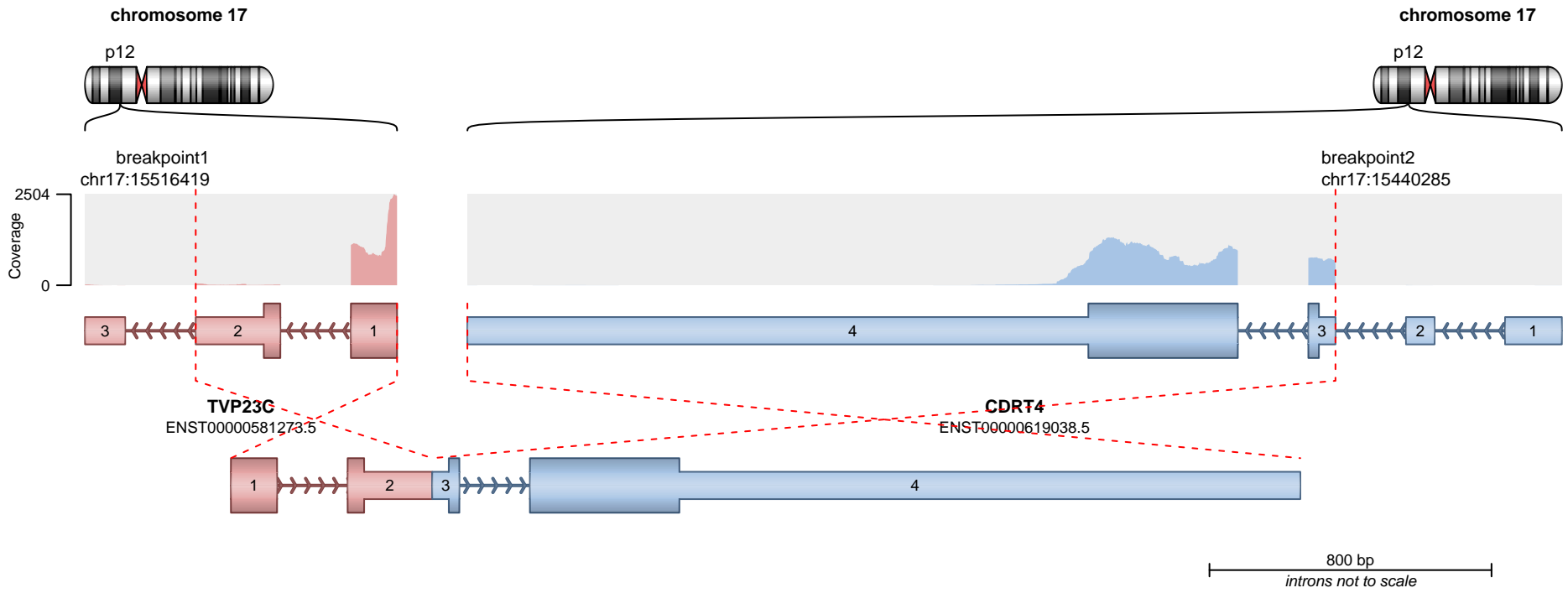

RETAINED PROTEIN DOMAINS
reading frame unclear

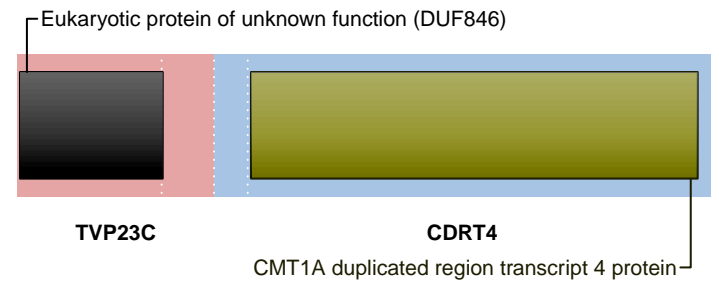

SUPPORTING READ COUNT

Split reads = 8
Discordant mates = 0

- translocation
- duplication
- deletion
- inversion

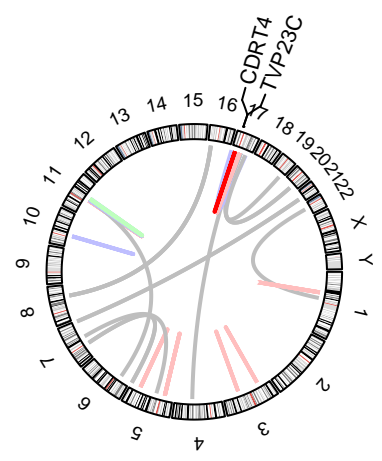
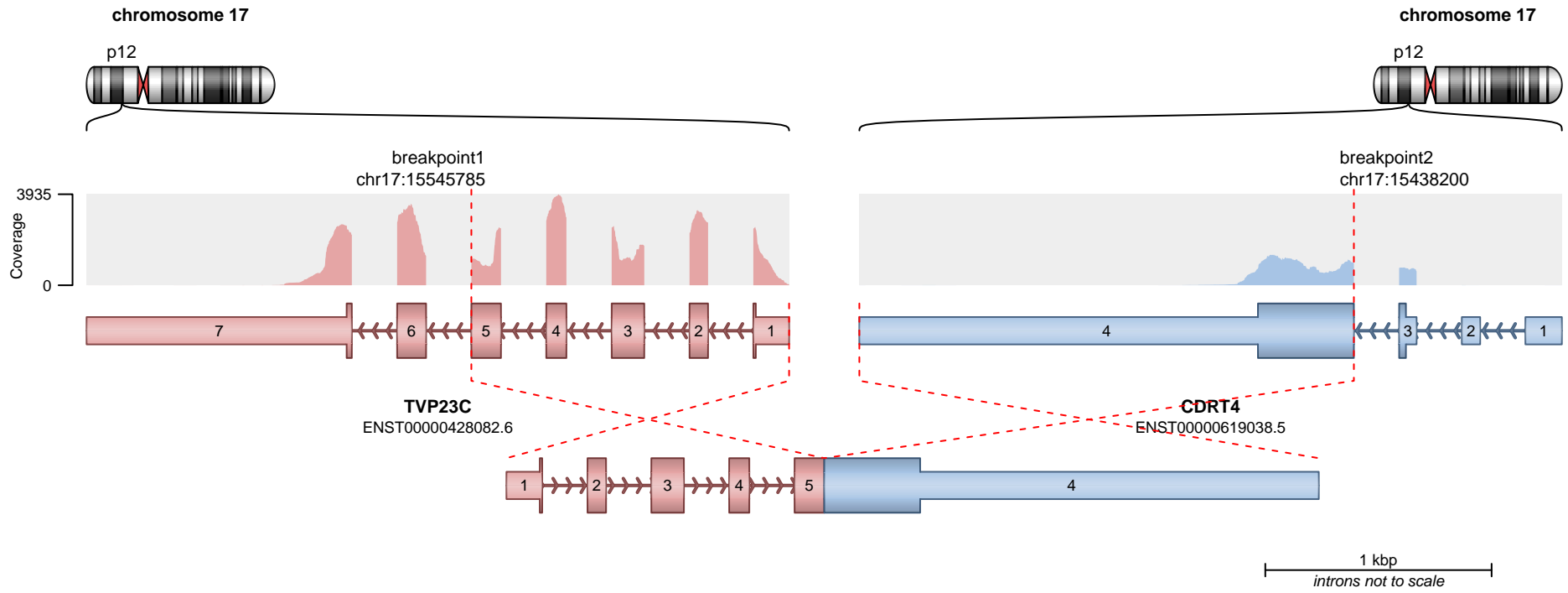

RETAINED PROTEIN DOMAINS
reading frame unclear

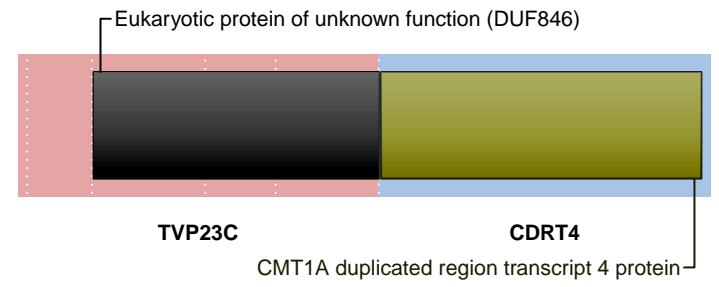

SUPPORTING READ COUNT

Split reads = 1
Discordant mates = 0

- translocation
- duplication
- deletion
- inversion

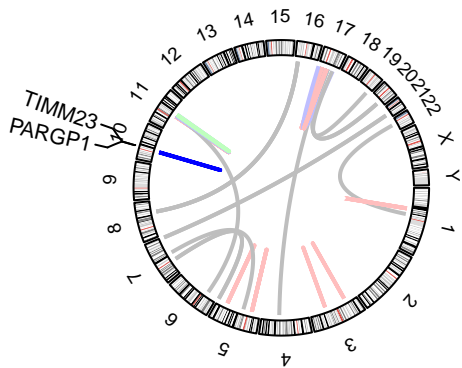
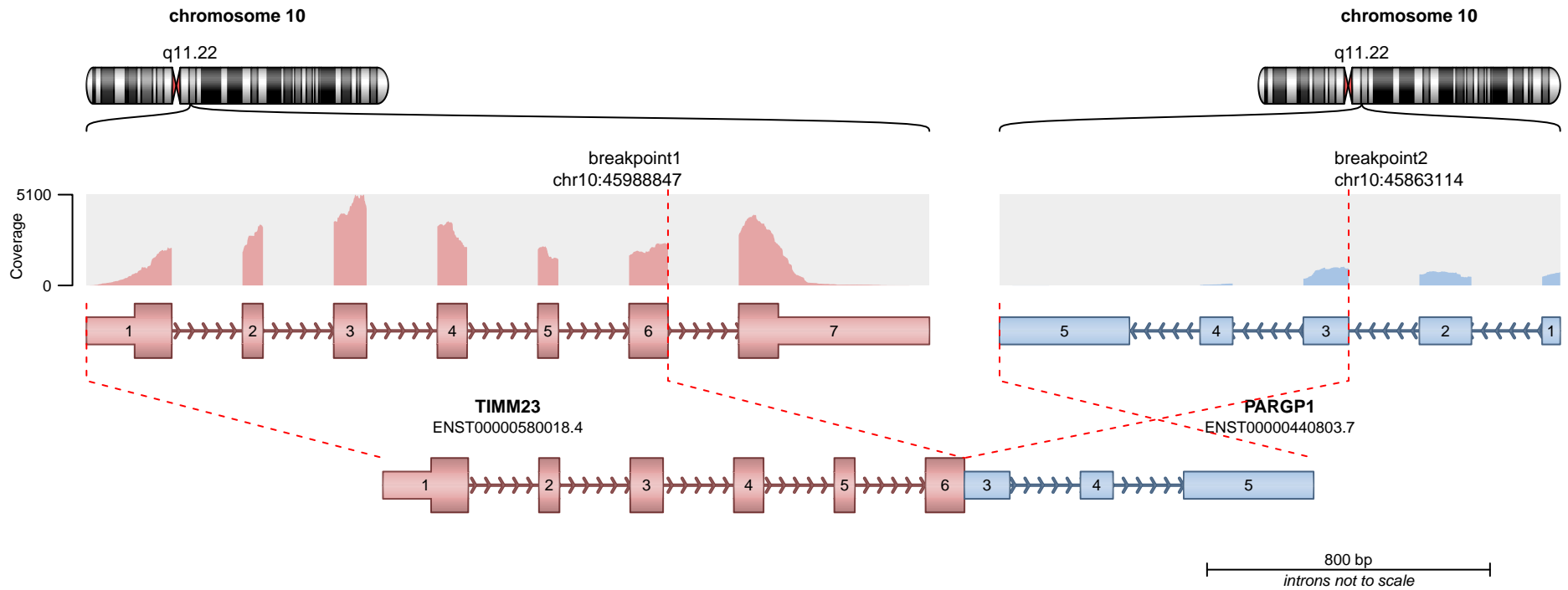

RETAINED PROTEIN DOMAINS
reading frame unclear

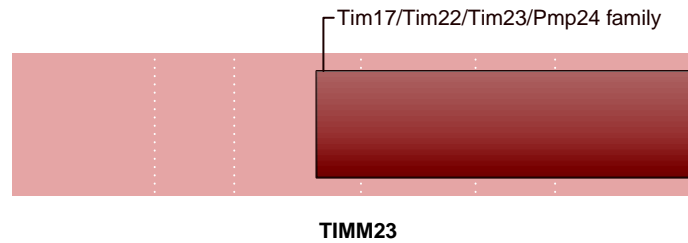

SUPPORTING READ COUNT

Split reads = 91
Discordant mates = 0

— translocation — deletion
— duplication — inversion

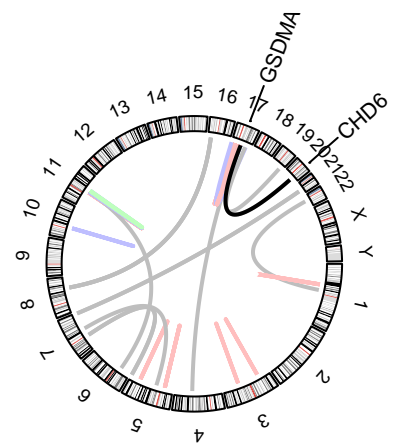
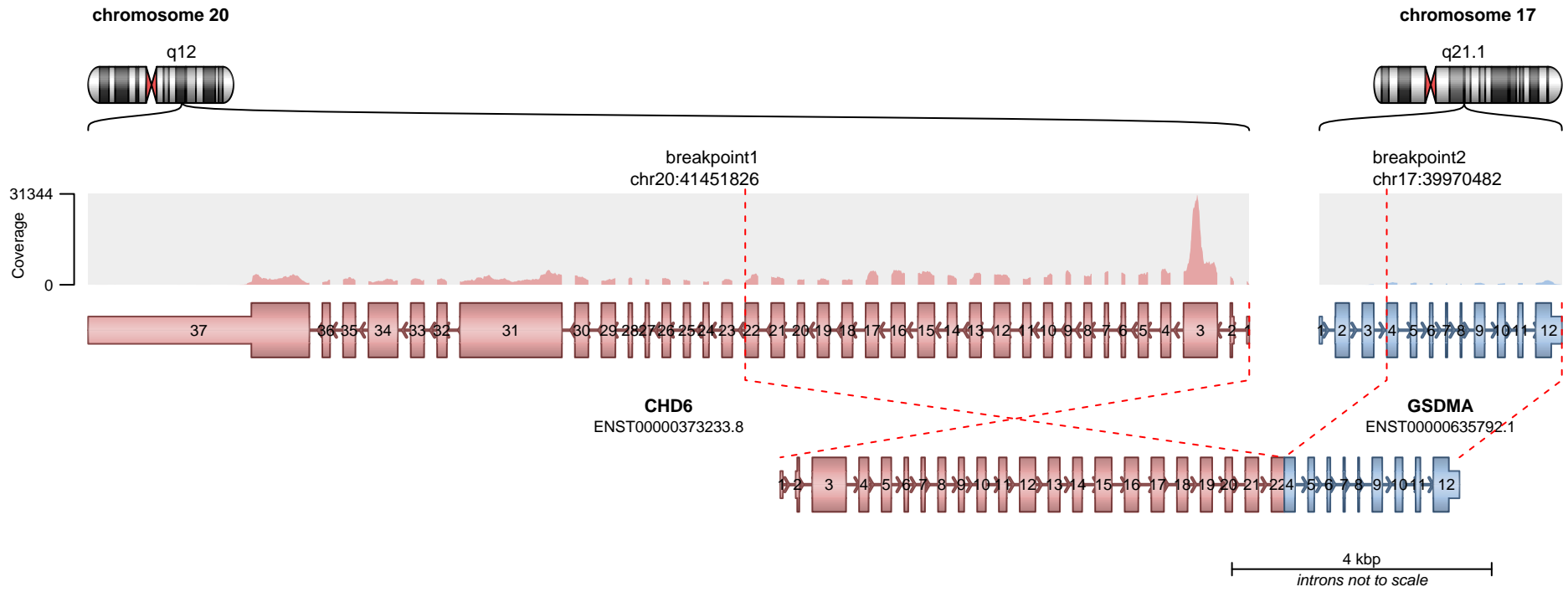

— translocation — deletion
— duplication — inversion

RETAINED PROTEIN DOMAINS
reading frame unclear

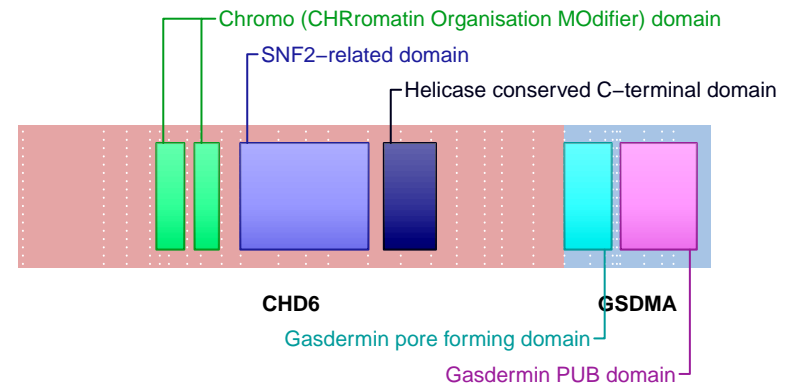

SUPPORTING READ COUNT

Split reads = 81
Discordant mates = 0

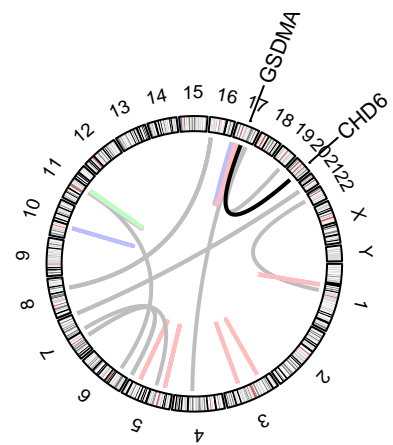
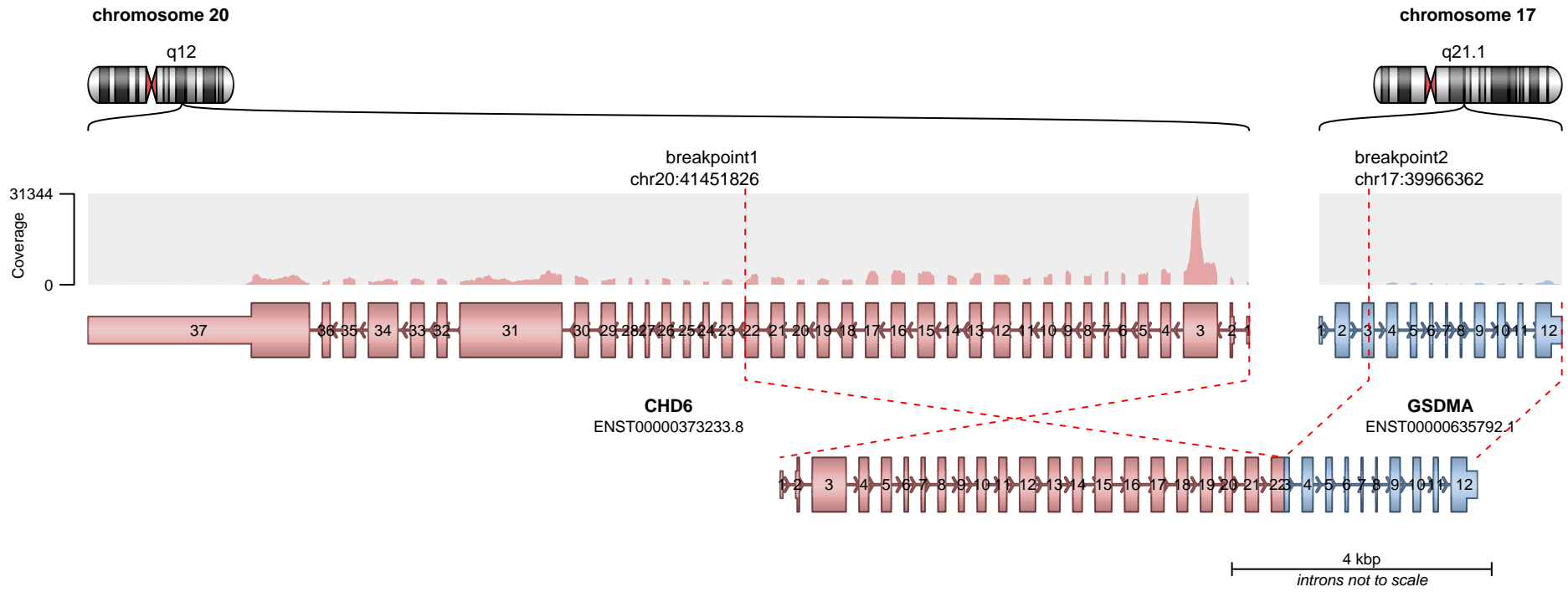

RETAINED PROTEIN DOMAINS
reading frame unclear

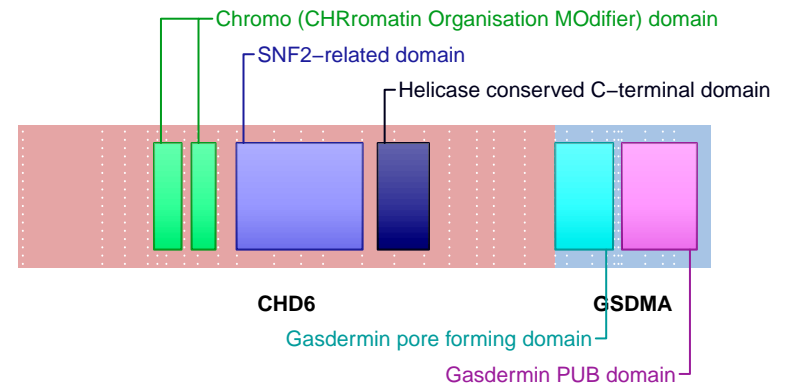

SUPPORTING READ COUNT

Split reads = 12
Discordant mates = 0

- translocation
- duplication
- deletion
- inversion

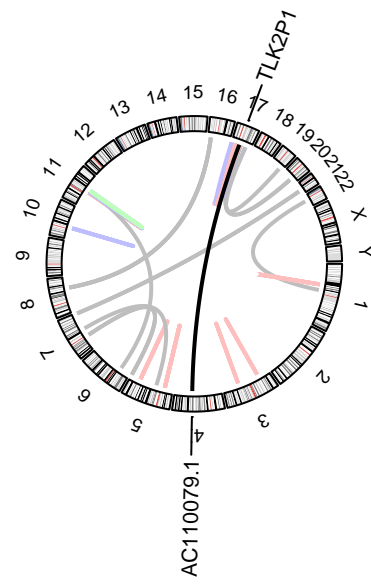
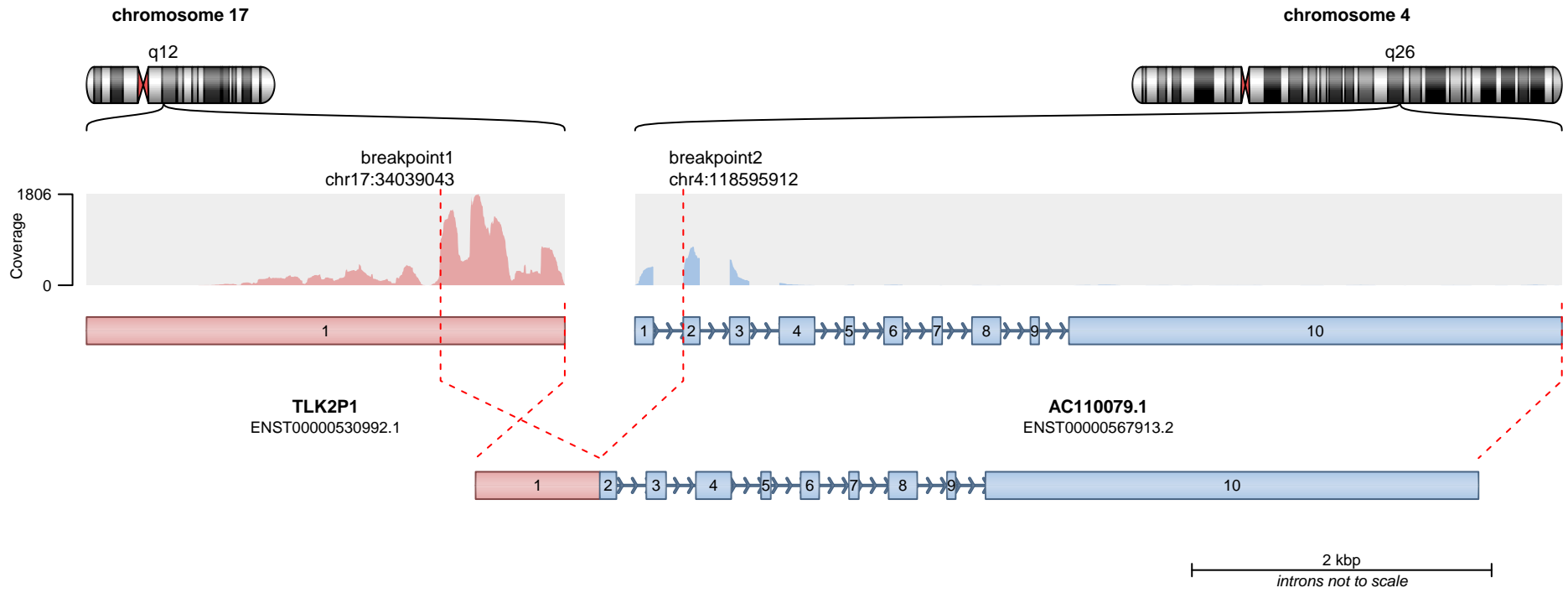

— translocation — deletion
 — duplication — inversion

Genes are not protein-coding.

SUPPORTING READ COUNT

Split reads = 78
Discordant mates = 0

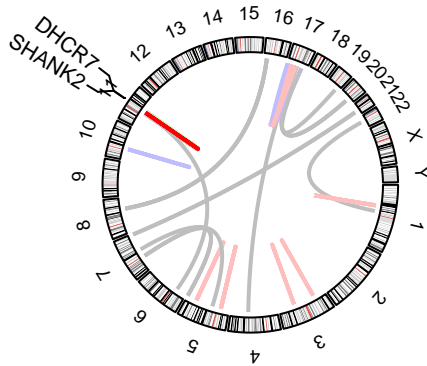
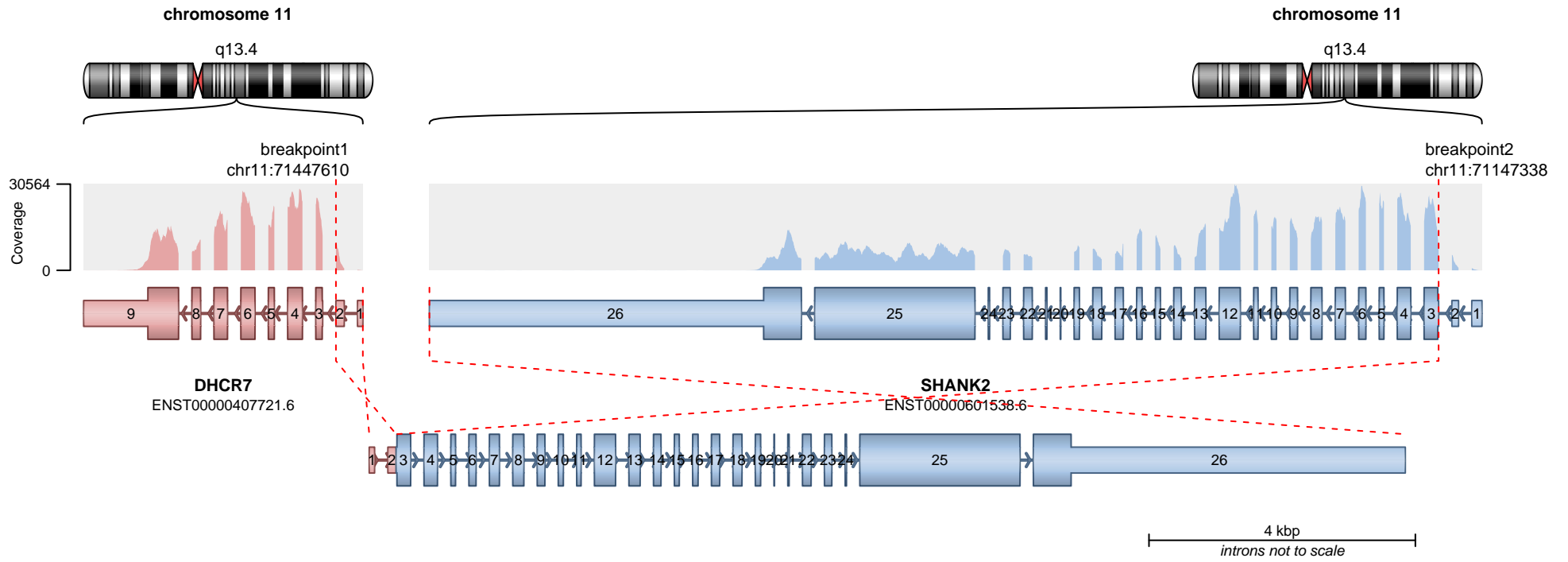

— translocation — deletion
 — duplication — inversion

RETAINED PROTEIN DOMAINS
reading frame unclear

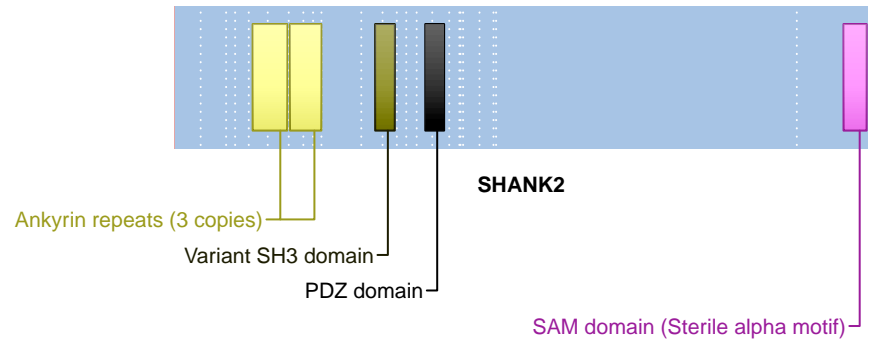

SUPPORTING READ COUNT

Split reads = 77
 Discordant mates = 0

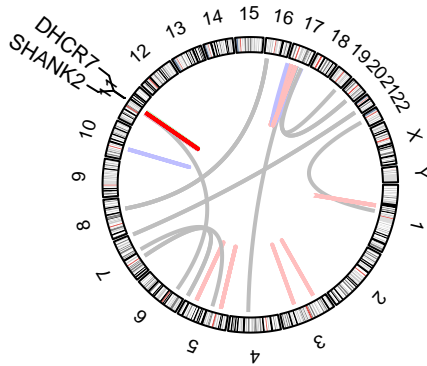
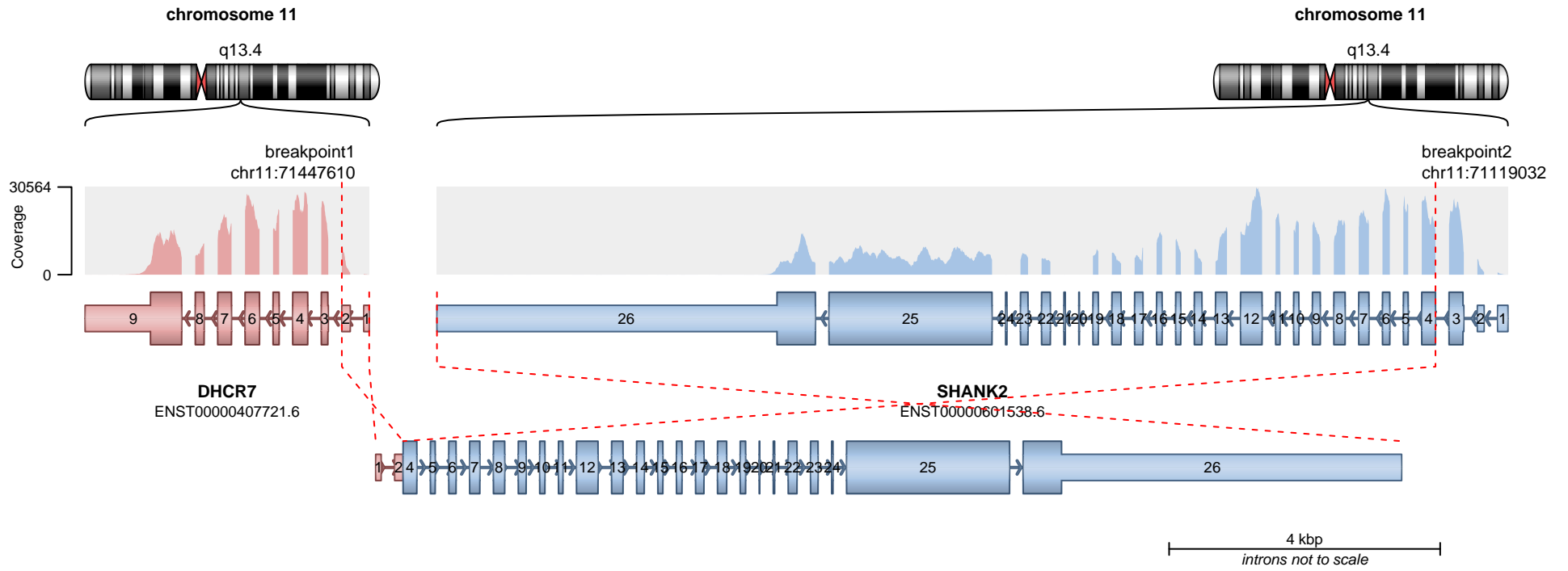

— translocation — deletion
— duplication — inversion

RETAINED PROTEIN DOMAINS
reading frame unclear

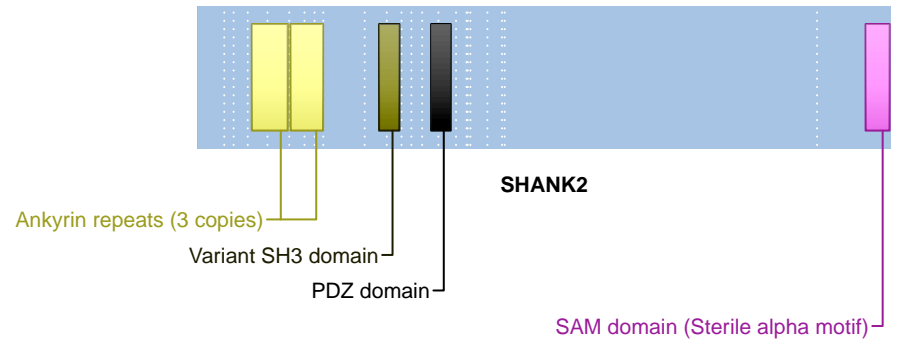

SUPPORTING READ COUNT

Split reads = 1
Discordant mates = 0

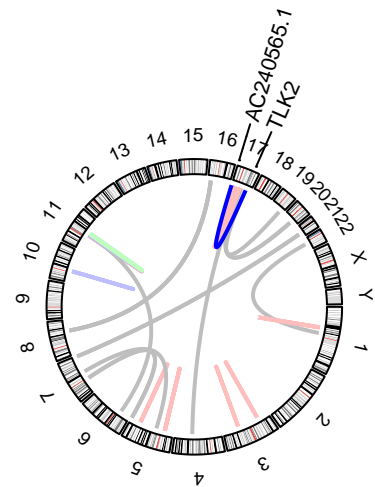
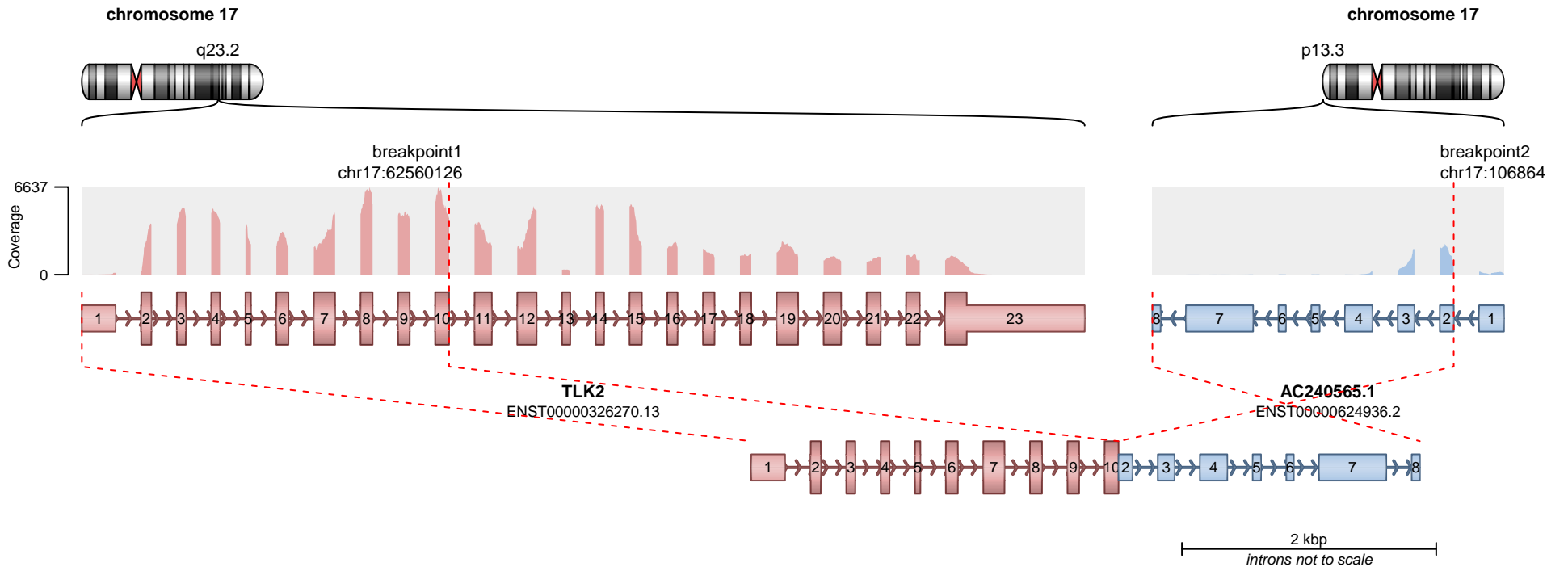

No protein domains retained in fusion.

SUPPORTING READ COUNT

Split reads = 72
Discordant mates = 2

— translocation — deletion
— duplication — inversion

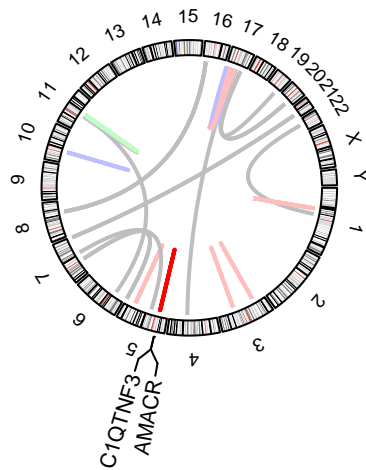
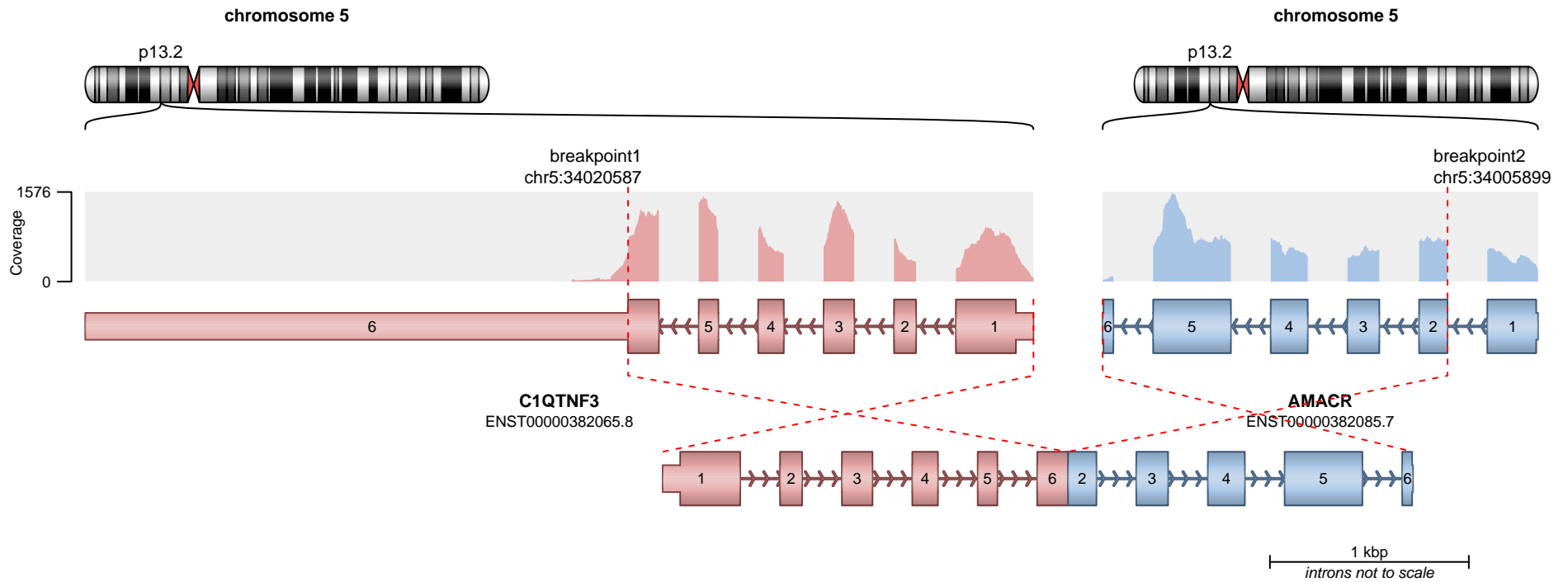

— translocation — deletion
— duplication — inversion

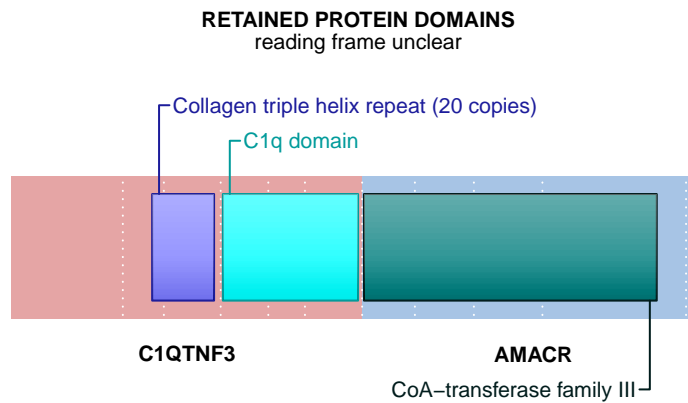

SUPPORTING READ COUNT

Split reads = 61
Discordant mates = 0

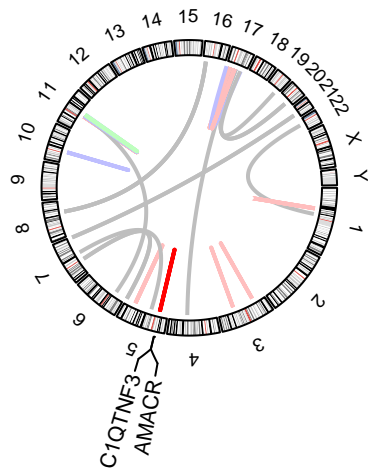
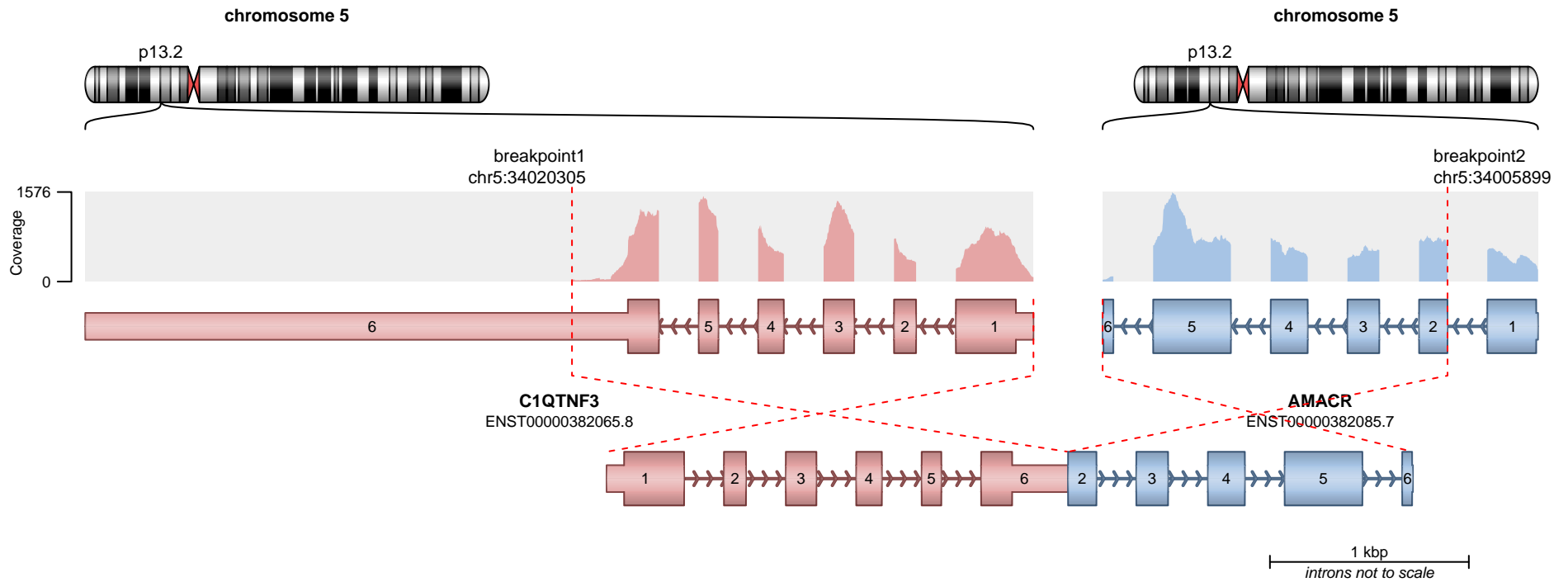

— translocation — deletion
— duplication — inversion

RETAINED PROTEIN DOMAINS
reading frame unclear

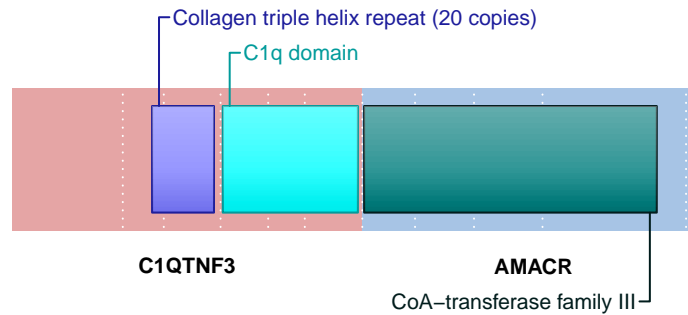

SUPPORTING READ COUNT

Split reads = 12
Discordant mates = 0

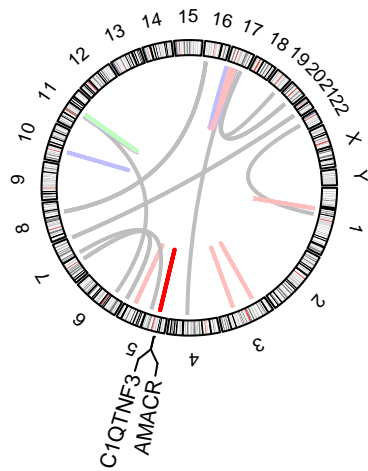
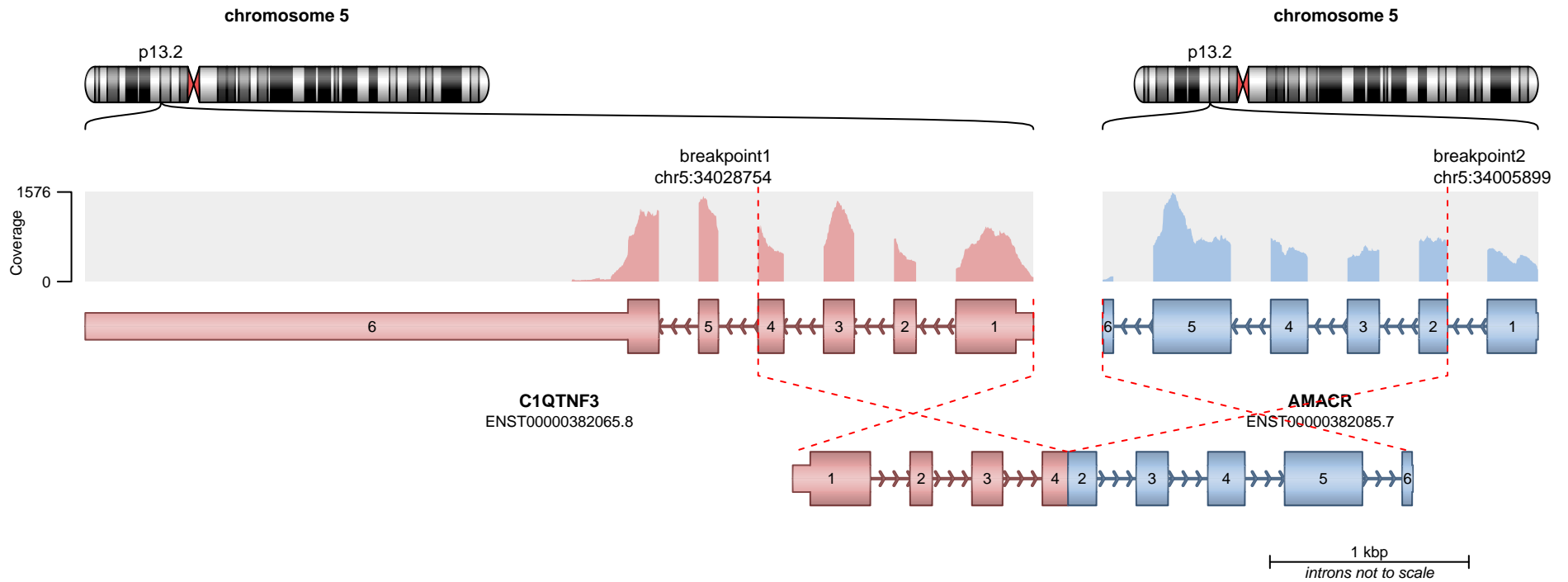

— translocation — deletion
— duplication — inversion

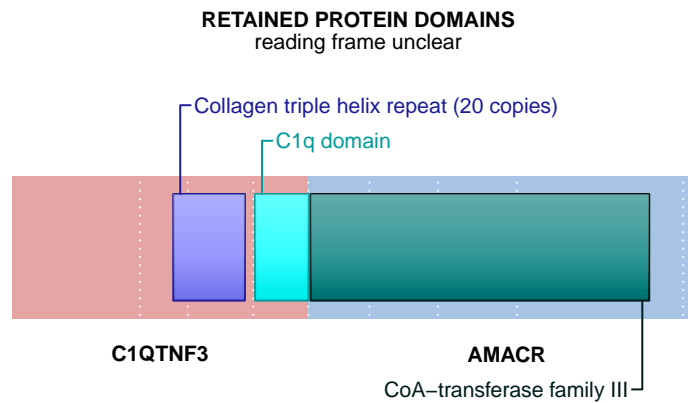

SUPPORTING READ COUNT

Split reads = 1
Discordant mates = 0

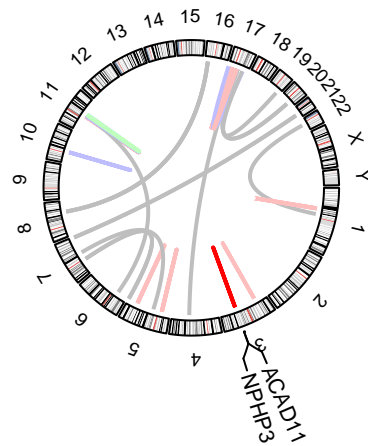
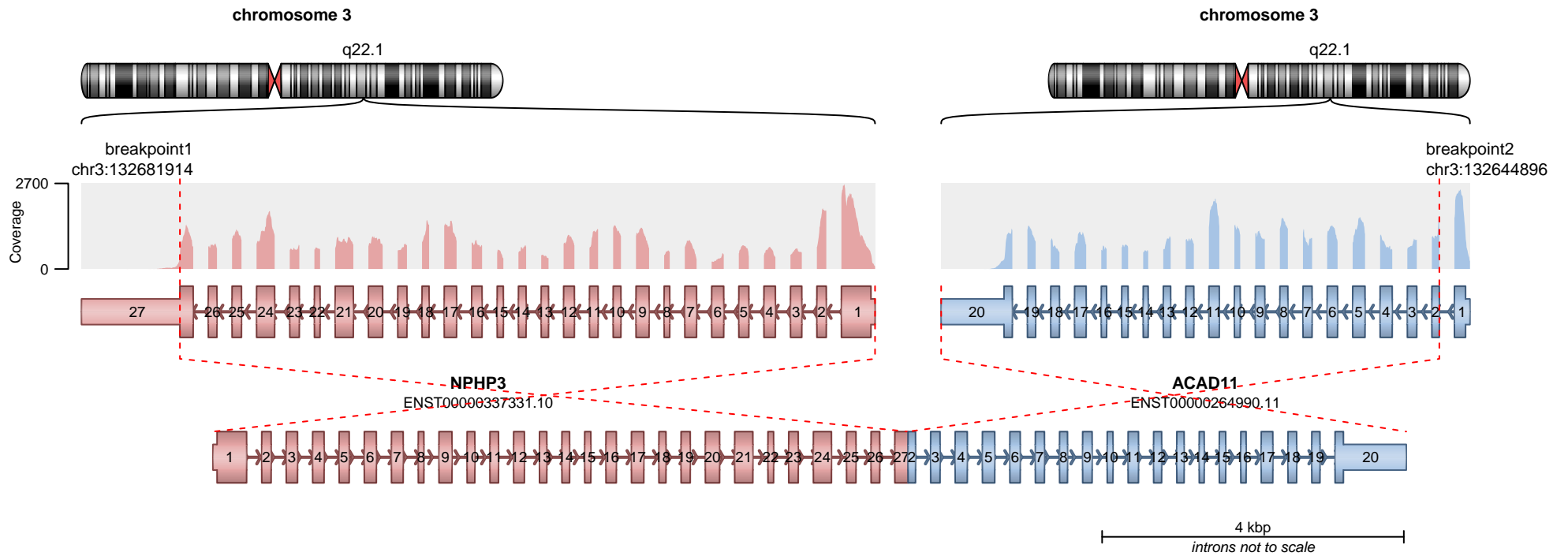

— translocation — deletion
— duplication — inversion

RETAINED PROTEIN DOMAINS
reading frame unclear

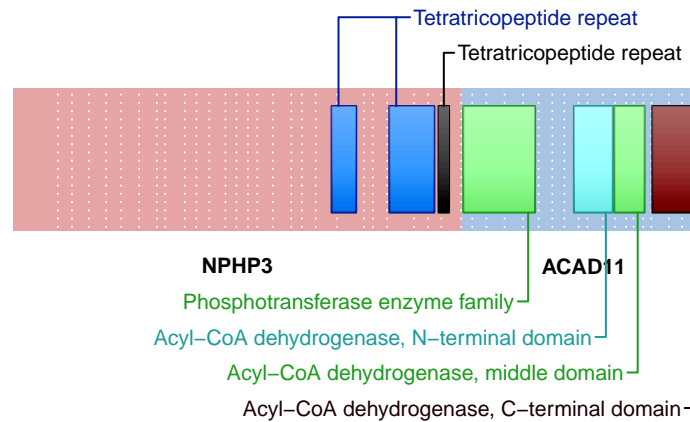

SUPPORTING READ COUNT

Split reads = 59
Discordant mates = 0

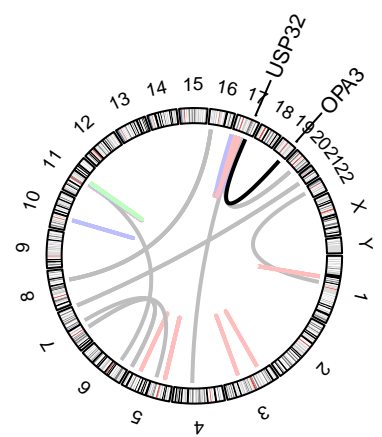
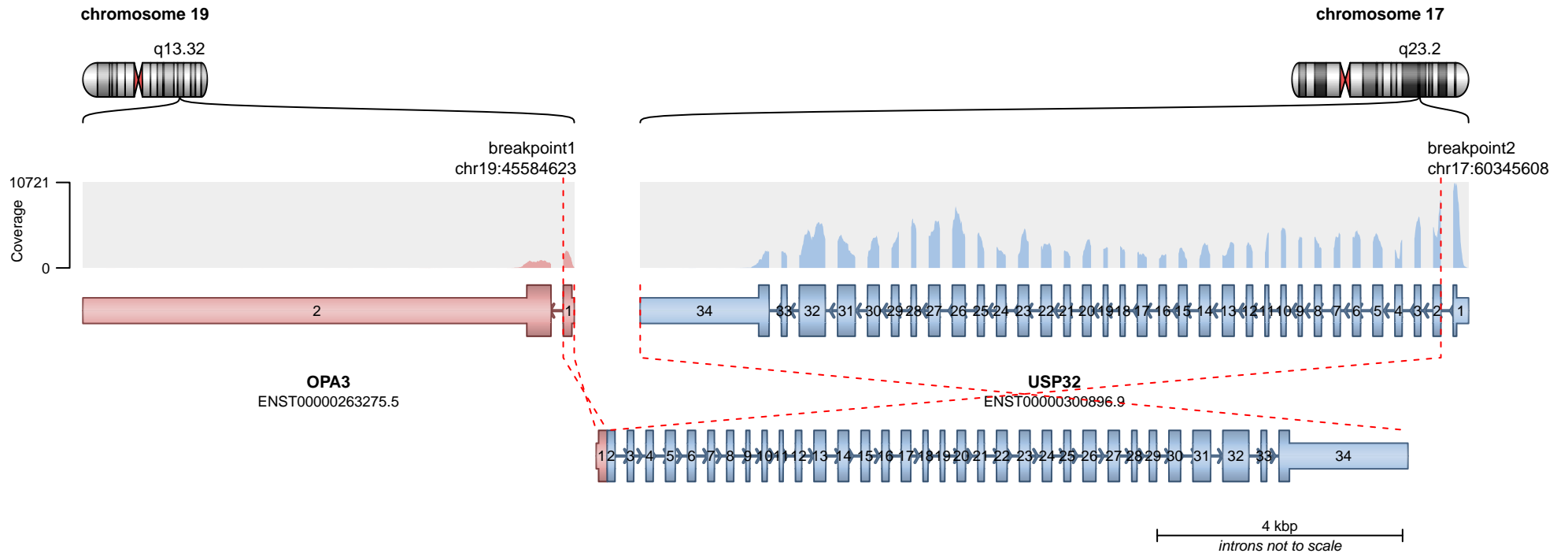

— translocation — deletion
— duplication — inversion

RETAINED PROTEIN DOMAINS
reading frame unclear

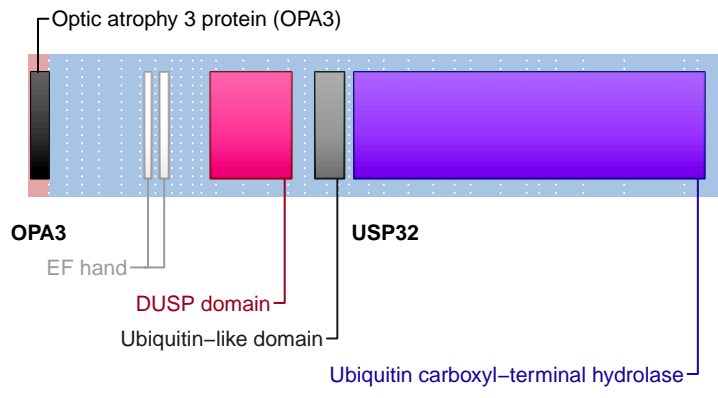

SUPPORTING READ COUNT

Split reads = 51
Discordant mates = 0

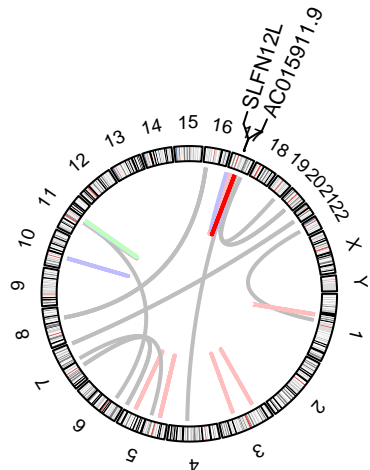
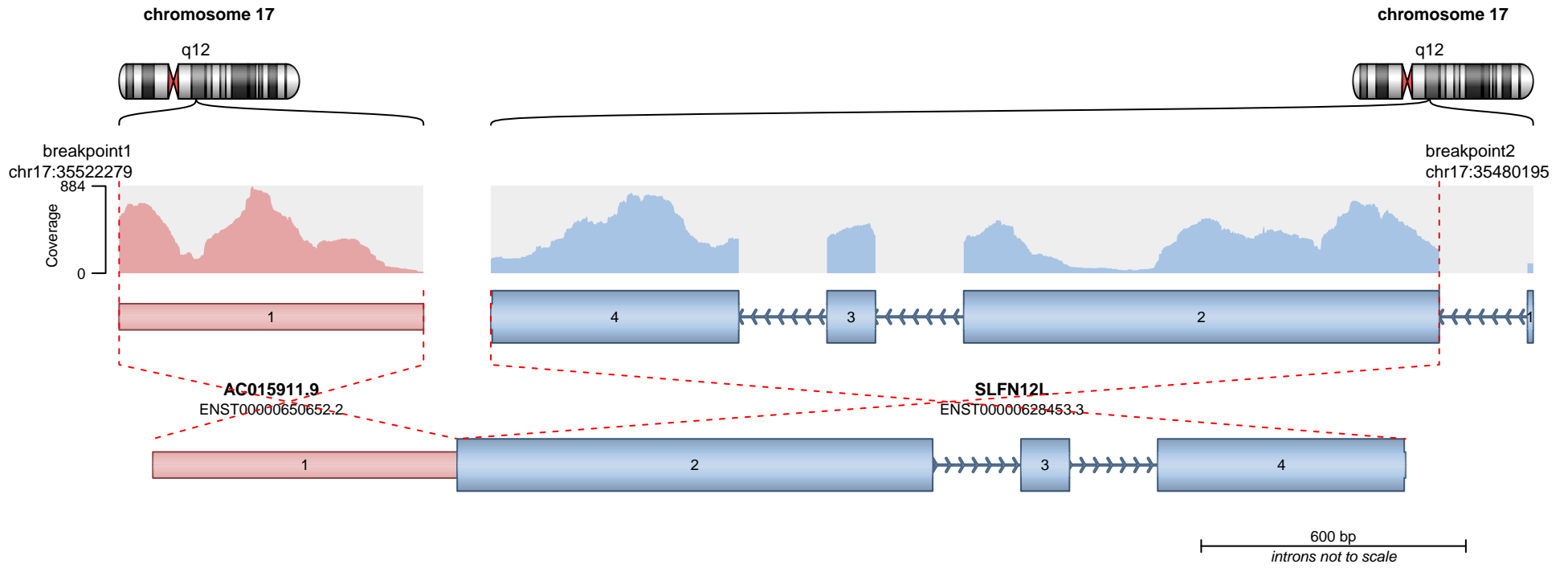

RETAINED PROTEIN DOMAINS
reading frame unclear

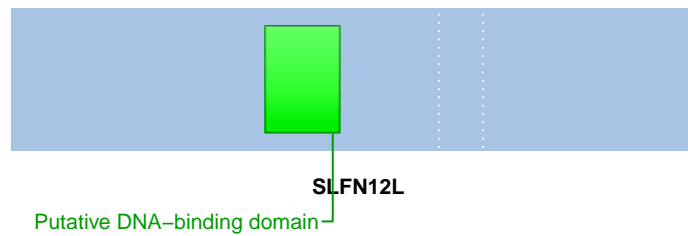

SUPPORTING READ COUNT

Split reads = 30
Discordant mates = 1

— translocation — deletion
— duplication — inversion

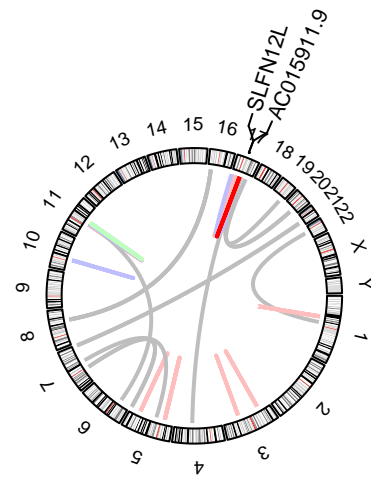
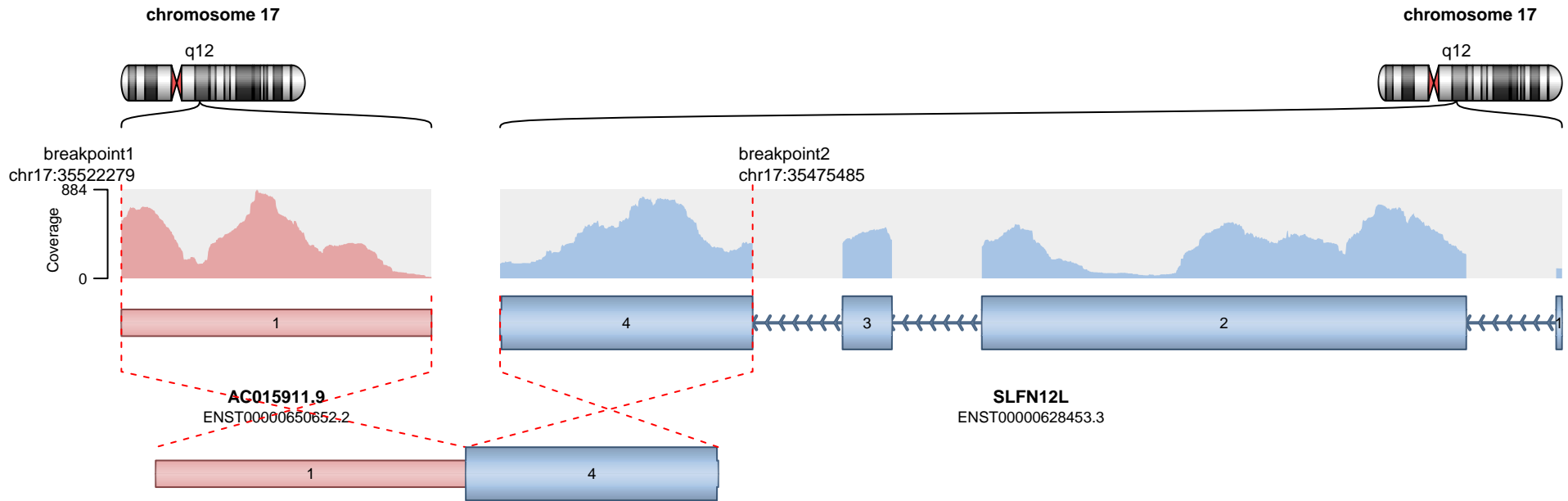

— translocation — deletion
— duplication — inversion

No protein domains retained in fusion.

SUPPORTING READ COUNT

Split reads = 12
Discordant mates = 0

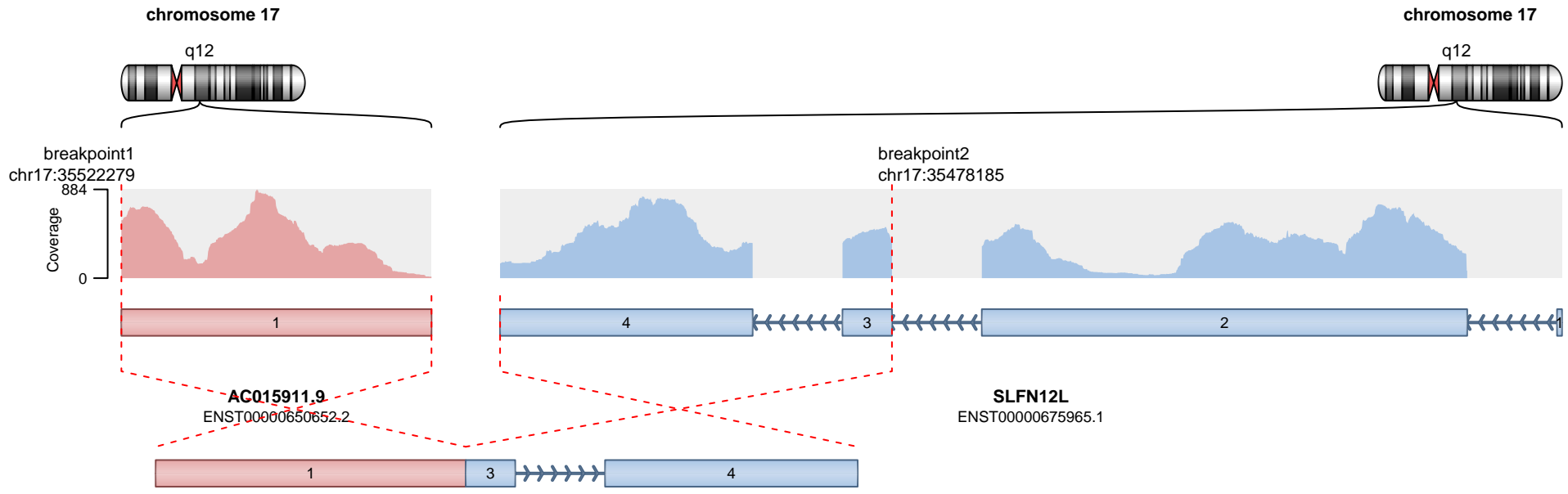

600 bp
introns not to scale

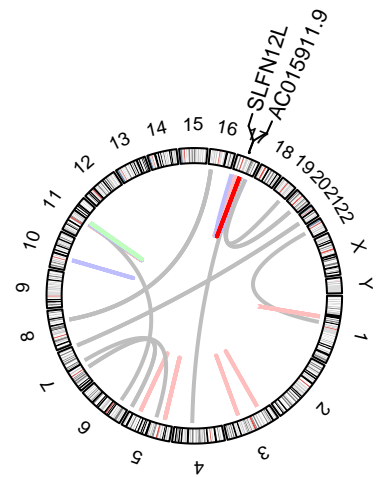

— translocation — deletion
— duplication — inversion

Genes are not protein-coding.

SUPPORTING READ COUNT

Split reads = 9
Discordant mates = 0

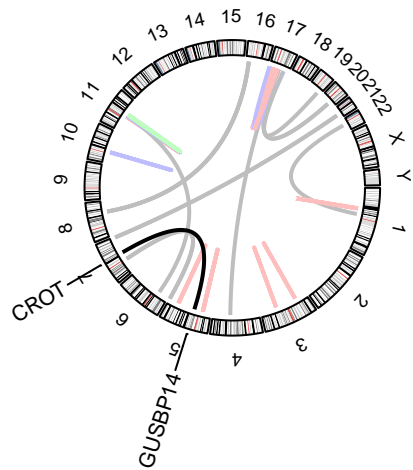
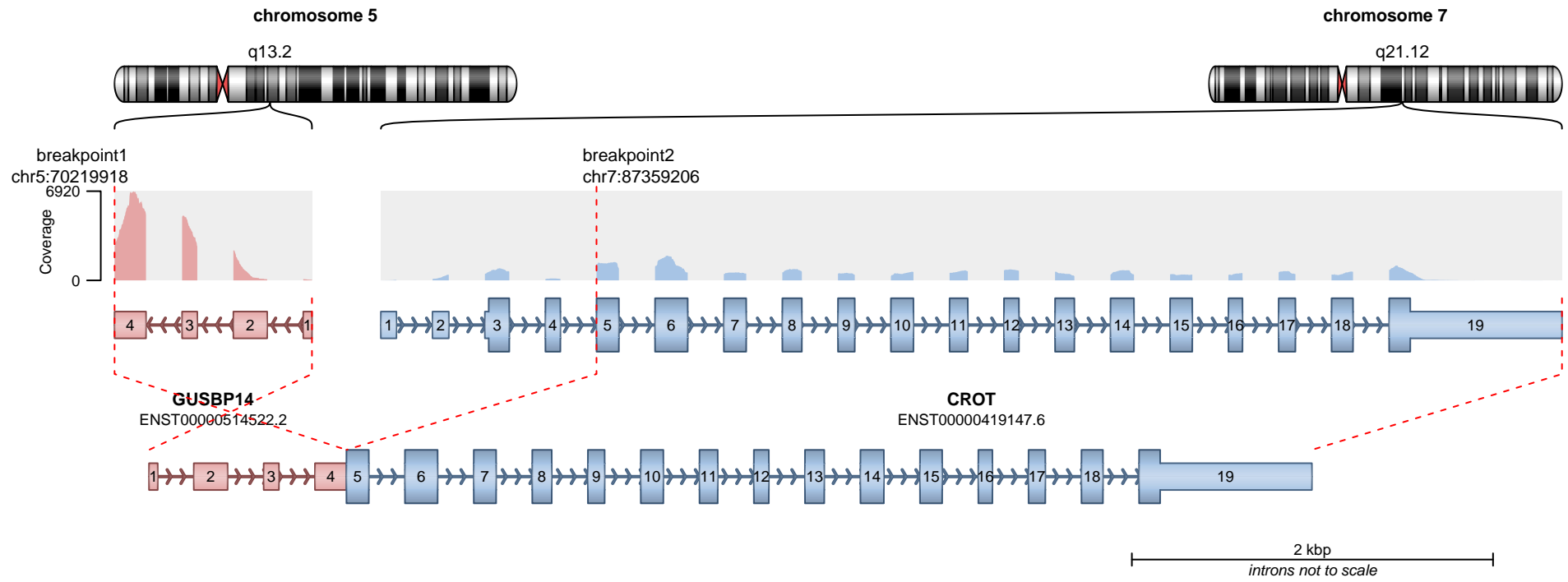

RETAINED PROTEIN DOMAINS
reading frame unclear

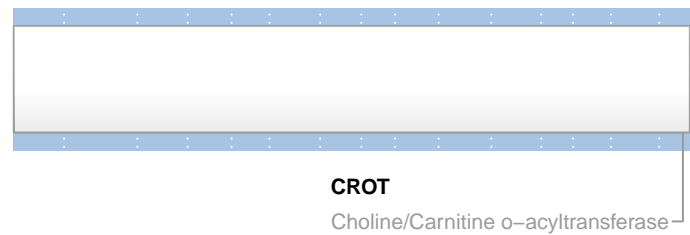

SUPPORTING READ COUNT

Split reads = 29
Discordant mates = 1

— translocation — deletion
— duplication — inversion

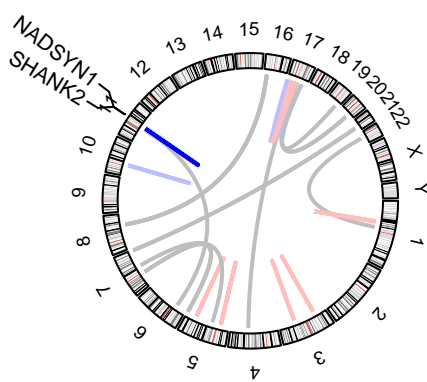
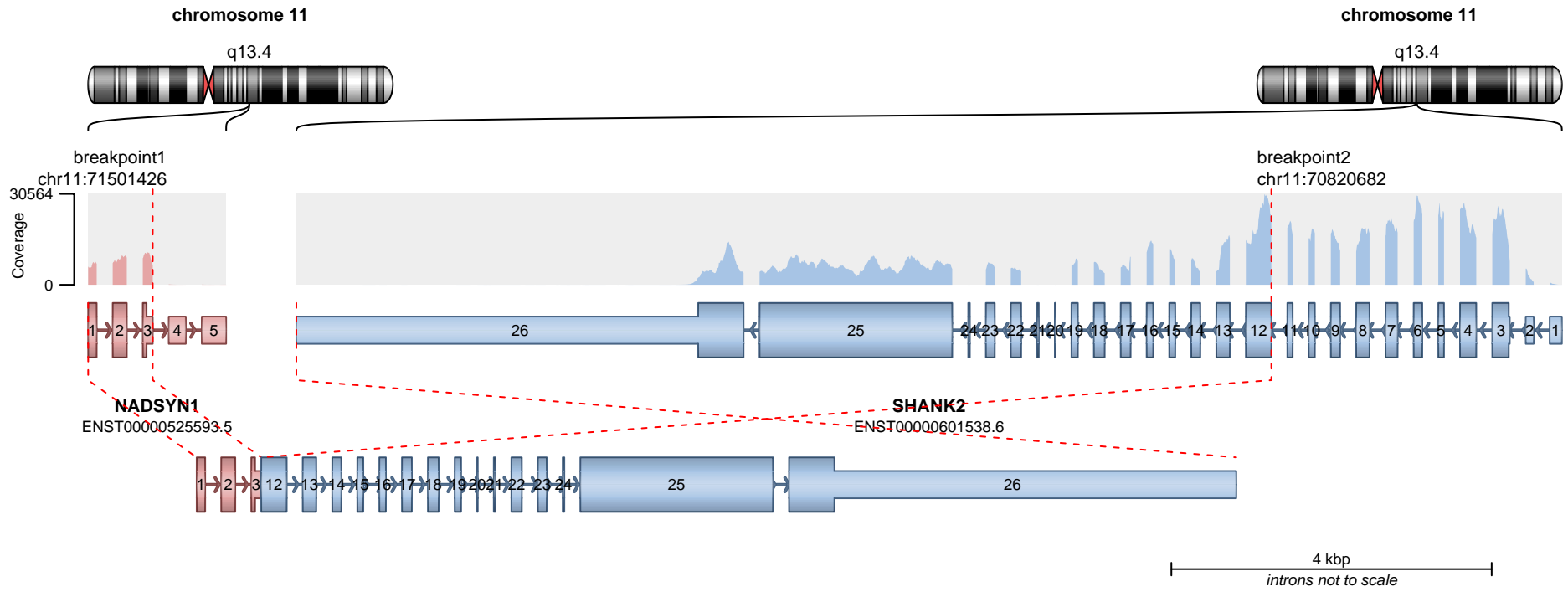

— translocation — deletion
— duplication — inversion

RETAINED PROTEIN DOMAINS
reading frame unclear

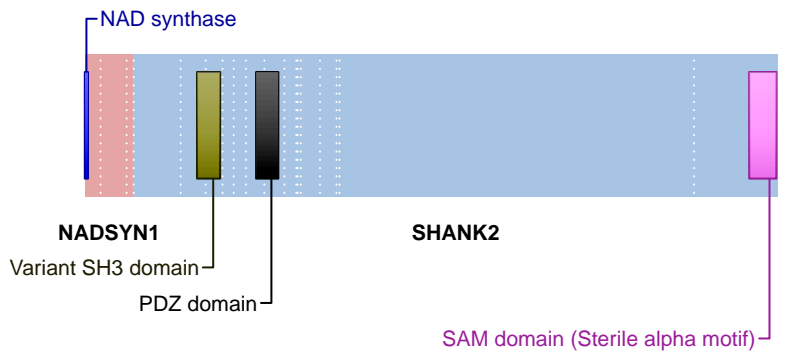

SUPPORTING READ COUNT

Split reads = 28
Discordant mates = 1

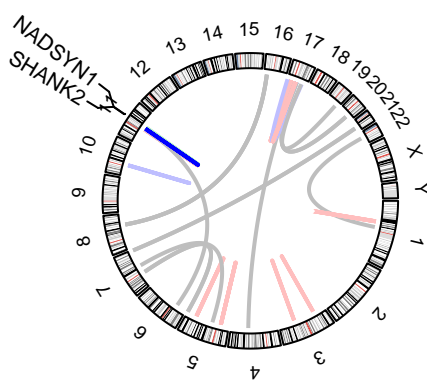
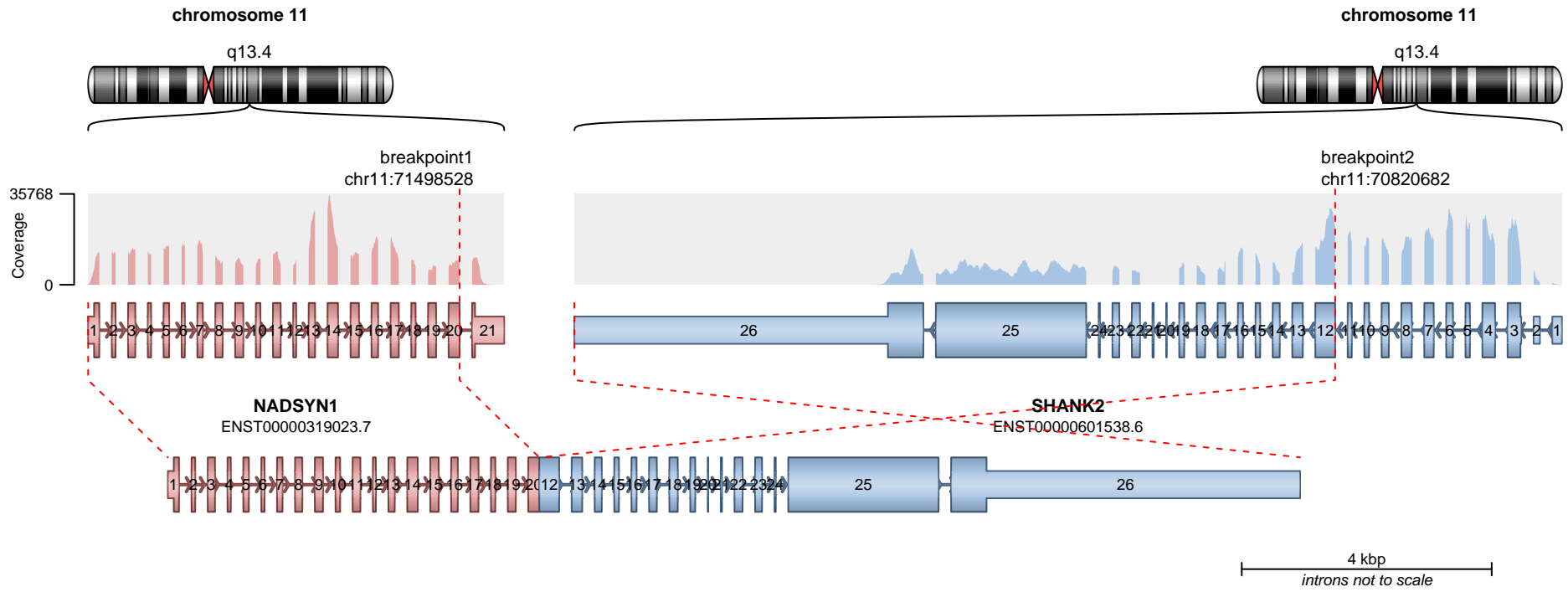

RETAINED PROTEIN DOMAINS
reading frame unclear

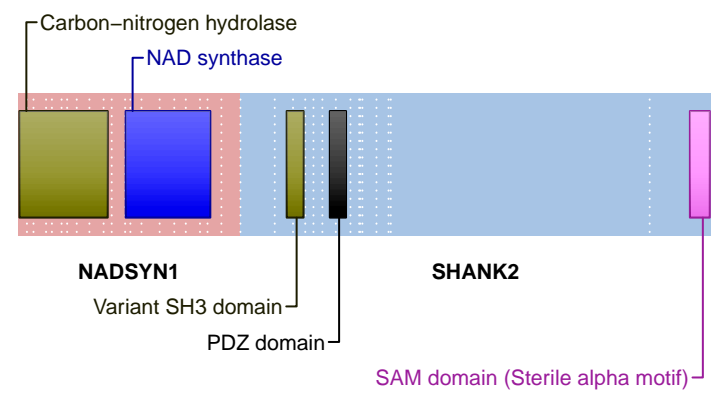

SUPPORTING READ COUNT

Split reads = 9
Discordant mates = 0

- translocation
- duplication
- deletion
- inversion

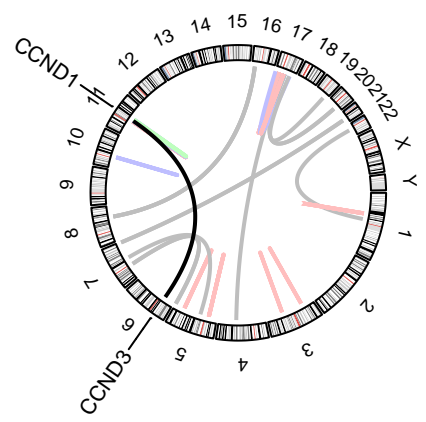
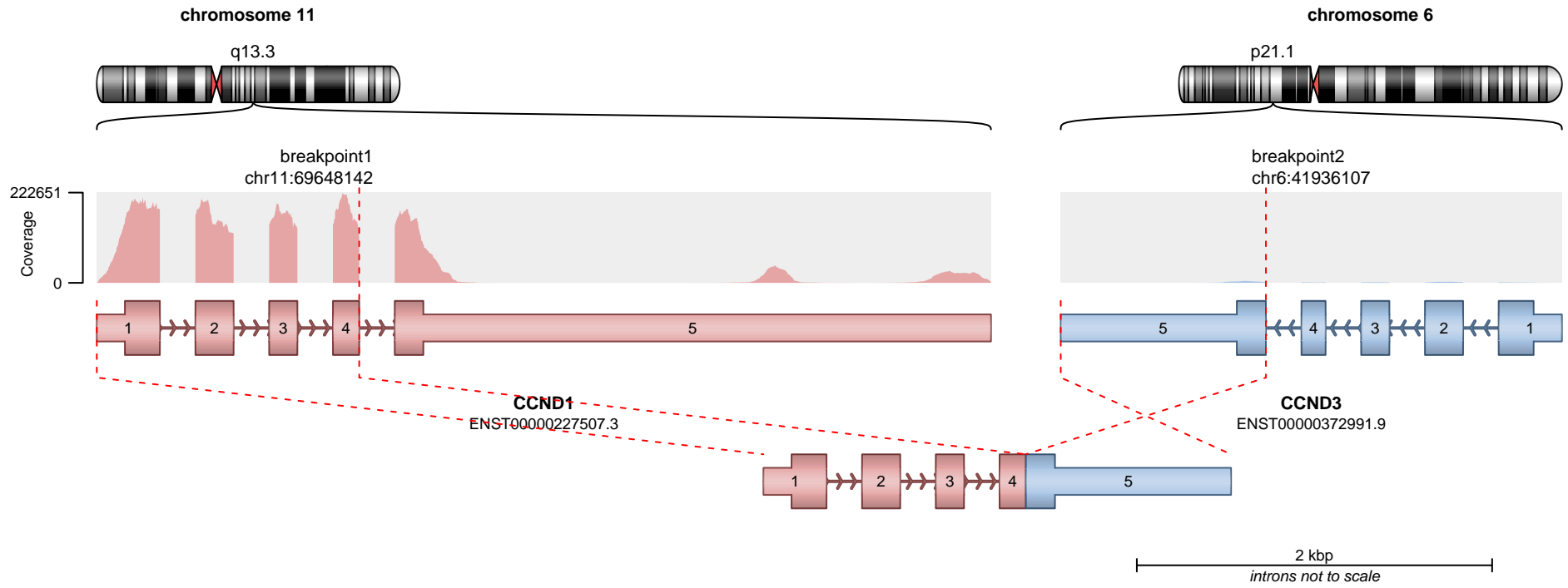

RETAINED PROTEIN DOMAINS
reading frame unclear

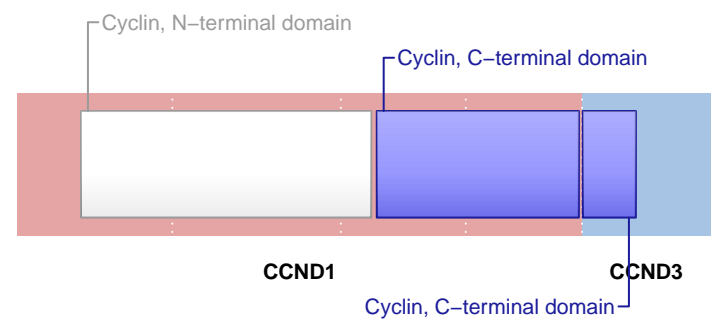

SUPPORTING READ COUNT

Split reads = 24
Discordant mates = 0

- translocation
- duplication
- deletion
- inversion

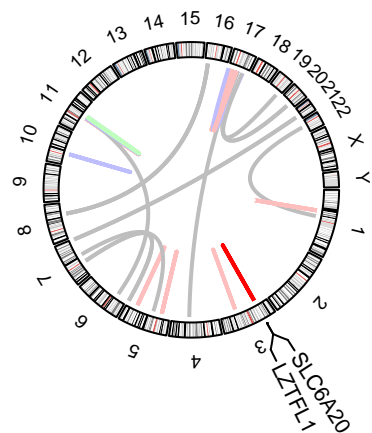
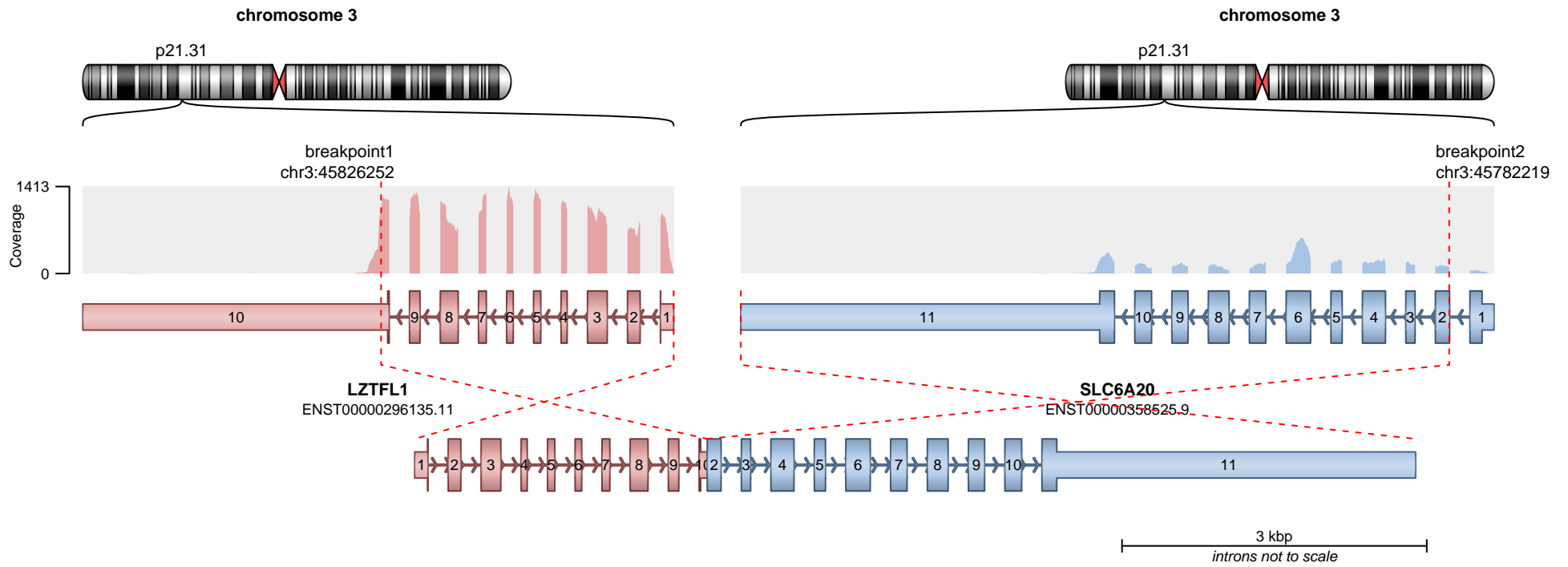

RETAINED PROTEIN DOMAINS
reading frame unclear

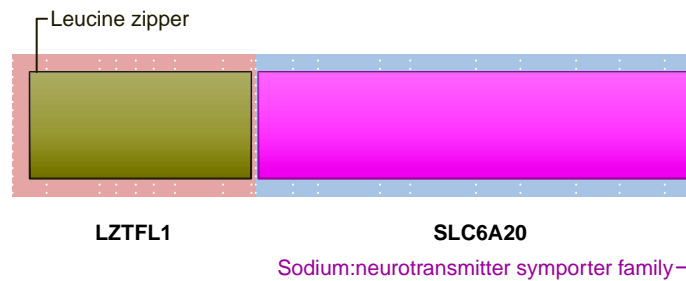

SUPPORTING READ COUNT

Split reads = 21
Discordant mates = 0

- translocation
- duplication
- deletion
- inversion

chromosome 21

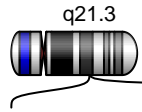

chromosome 7

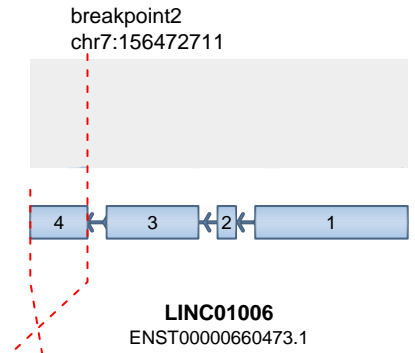
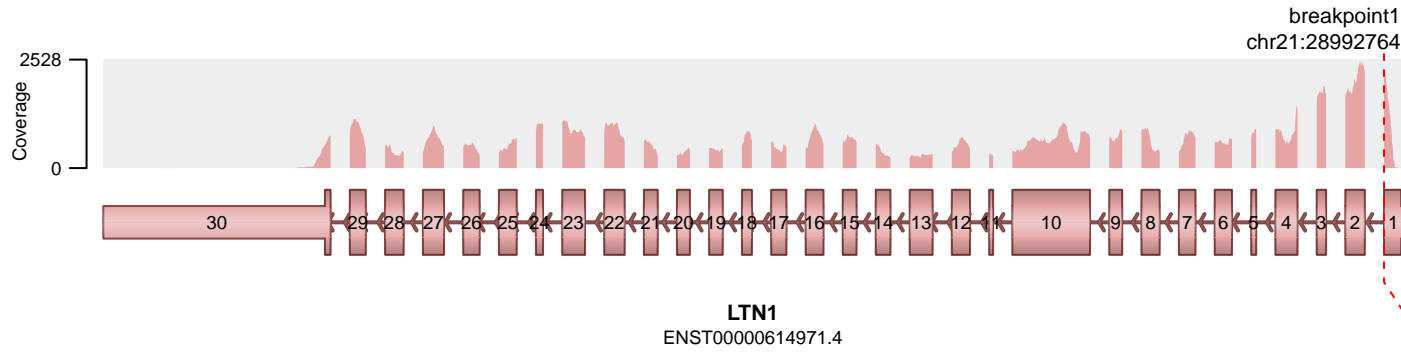
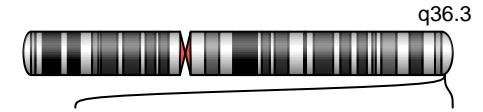

3 kbp
introns not to scale

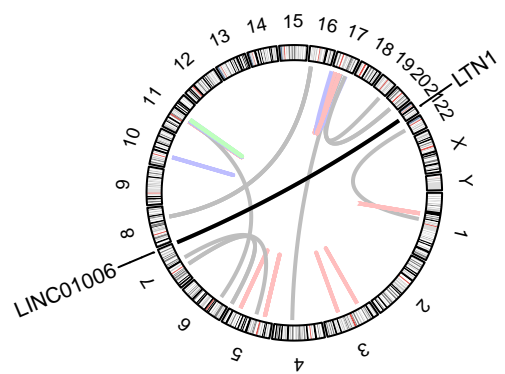

No protein domains retained in fusion.

SUPPORTING READ COUNT

Split reads = 20
Discordant mates = 0

— translocation — deletion
— duplication — inversion

chromosome 21

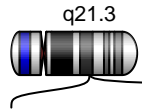

chromosome 7

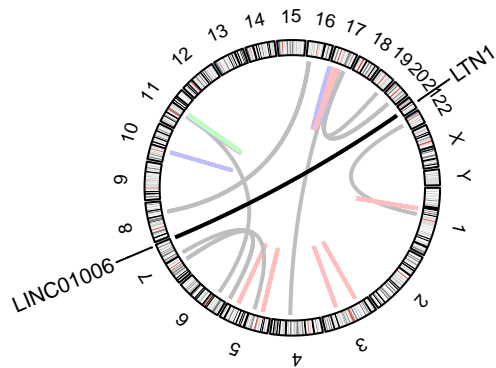
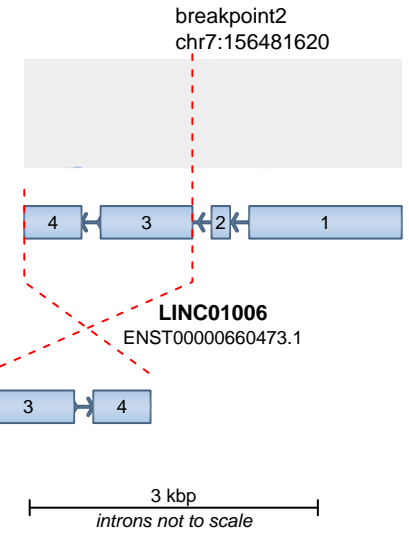
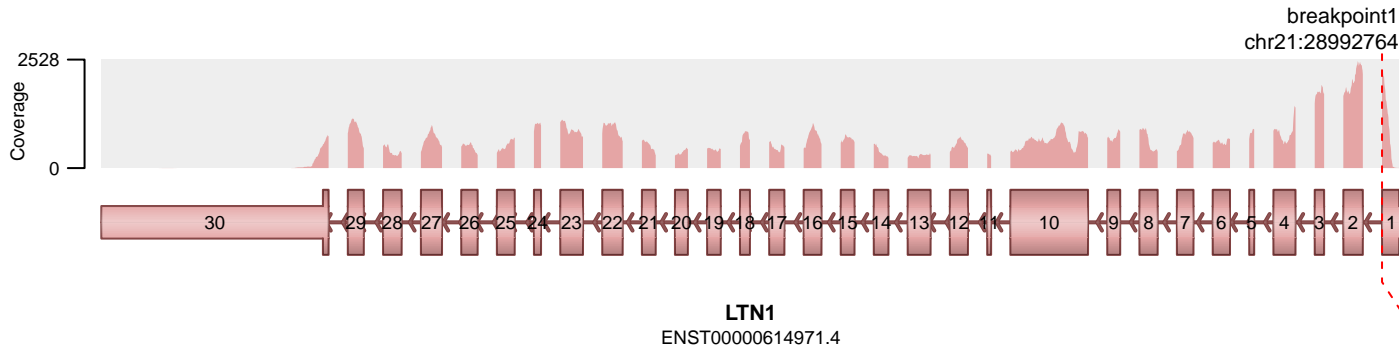
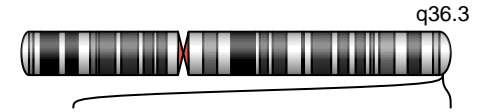

— translocation — deletion
— duplication — inversion

No protein domains retained in fusion.

SUPPORTING READ COUNT

Split reads = 1
Discordant mates = 0

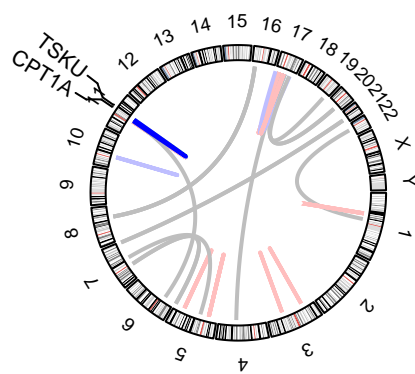
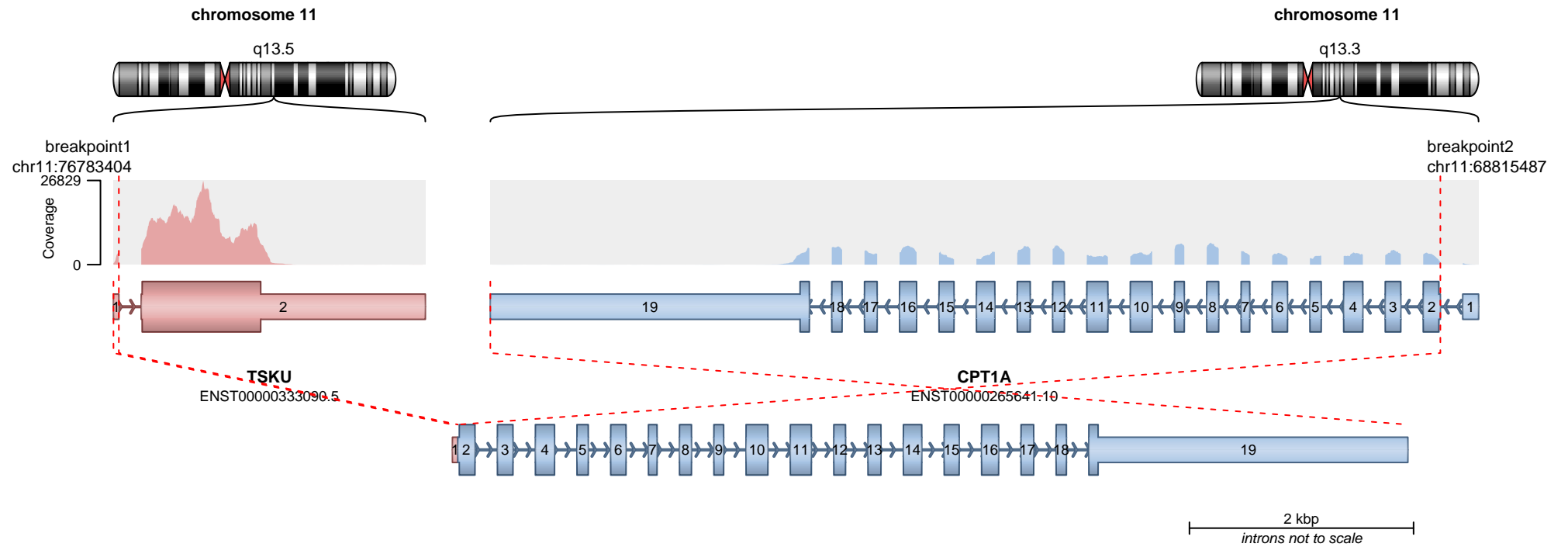

Carnitine O-palmitoyltransferase N-terminus

RETAINED PROTEIN DOMAINS
reading frame unclear

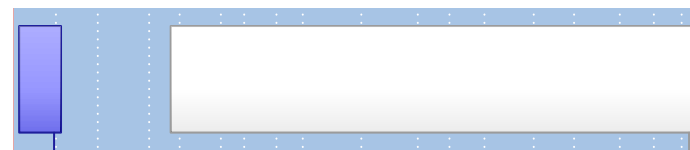

CPT1A

Choline/Carnitine o-acyltransferase

SUPPORTING READ COUNT

Split reads = 18
Discordant mates = 0

— translocation — deletion
— duplication — inversion

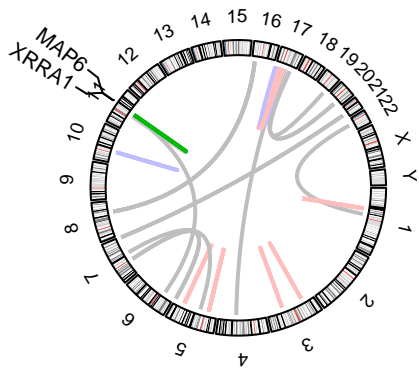
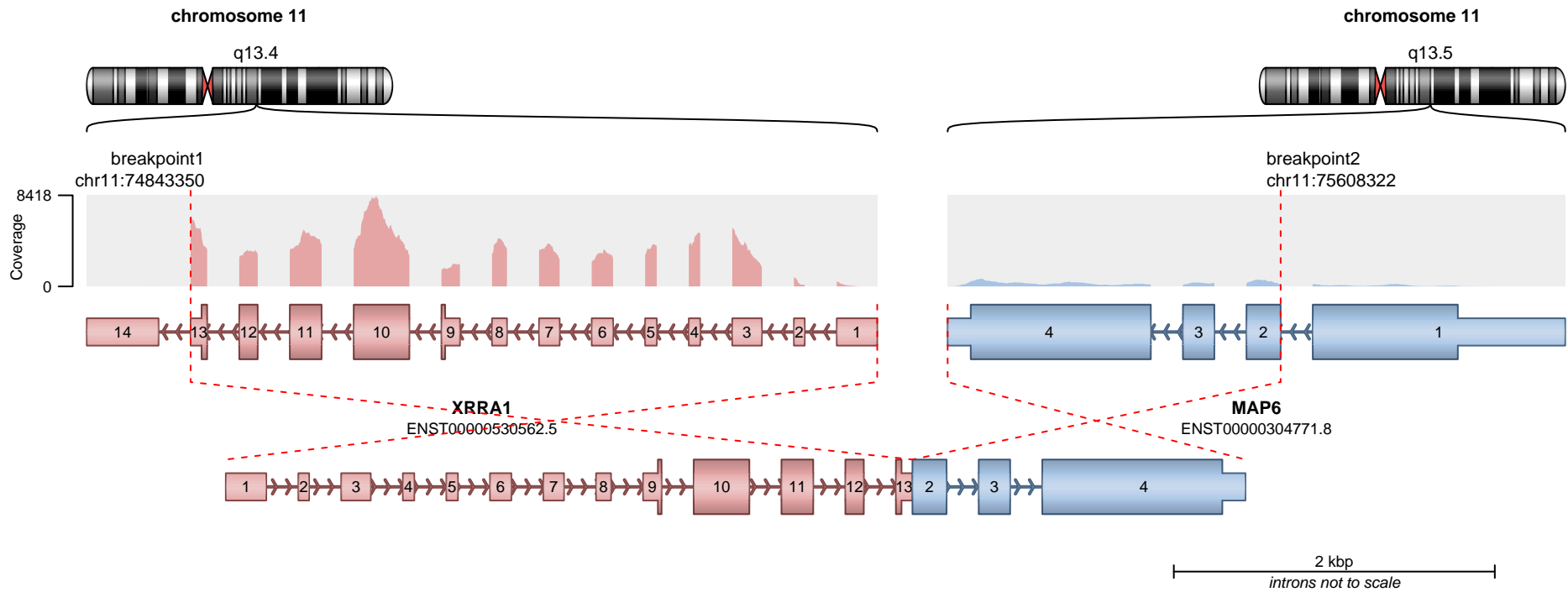

No protein domains retained in fusion.

SUPPORTING READ COUNT

Split reads = 18
Discordant mates = 0

— translocation — deletion
— duplication — inversion

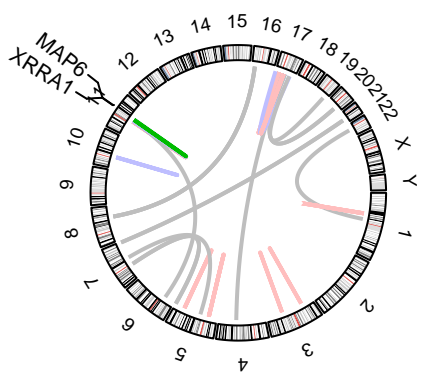
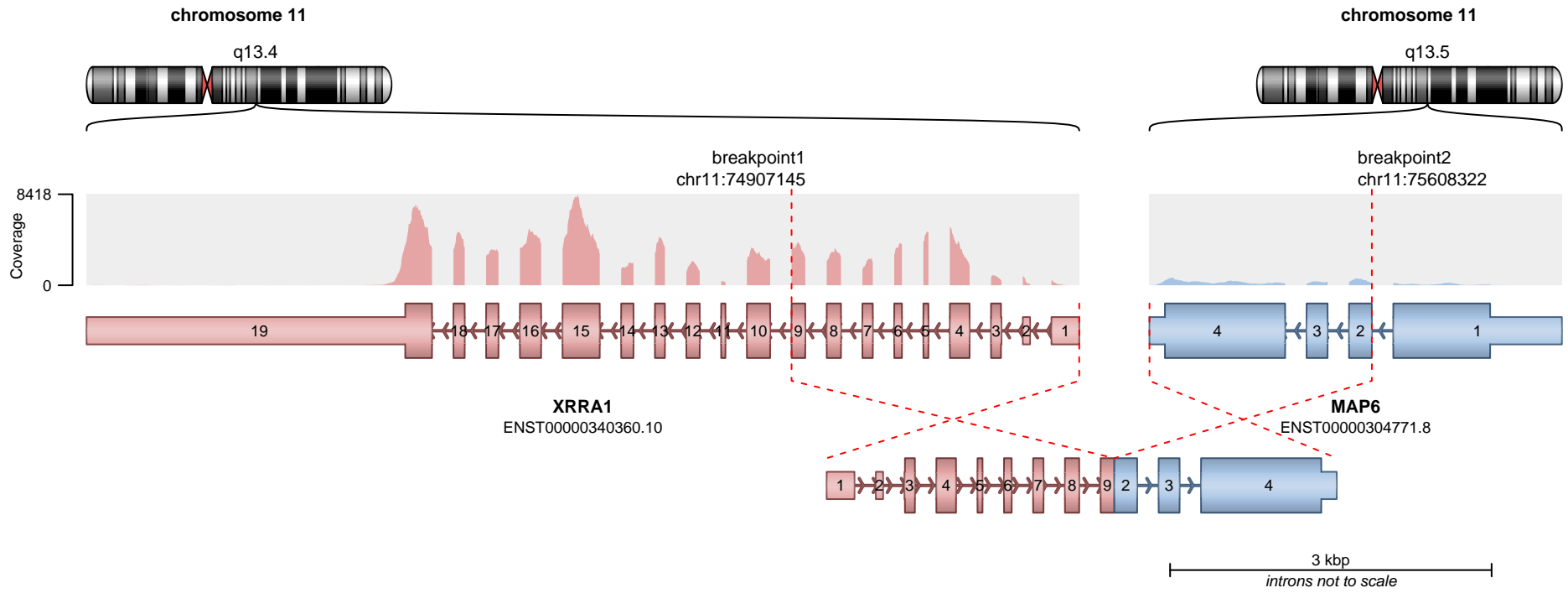

— translocation — deletion
— duplication — inversion

No protein domains retained in fusion.

SUPPORTING READ COUNT

Split reads = 2
Discordant mates = 0

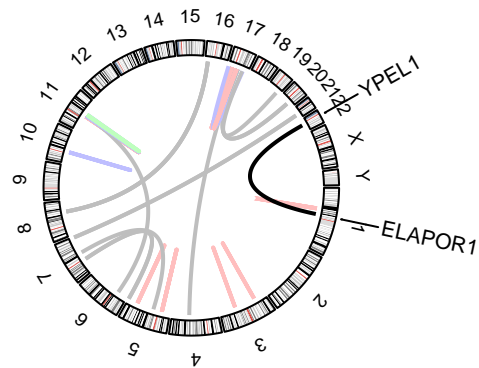
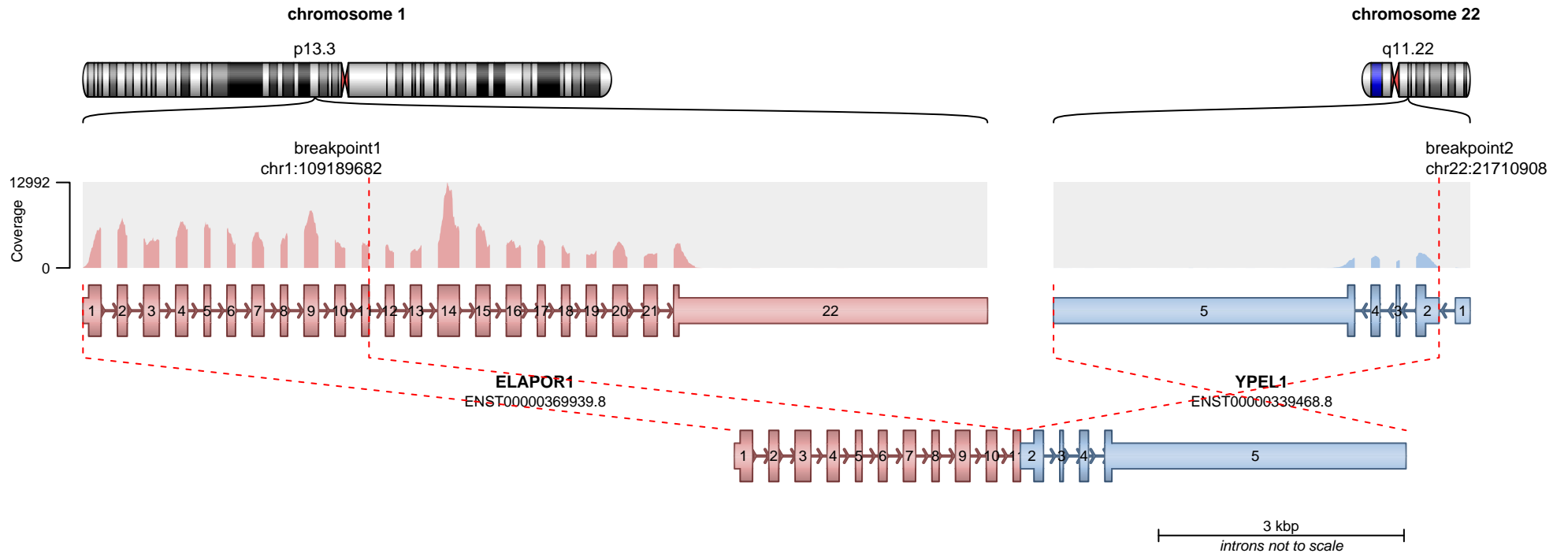

RETAINED PROTEIN DOMAINS
reading frame unclear

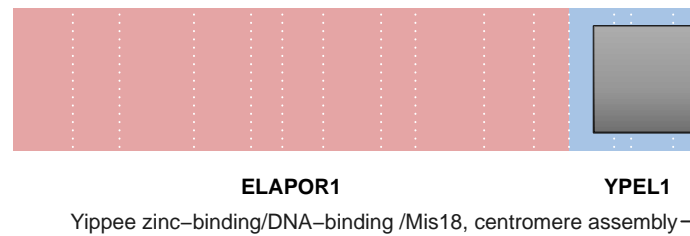

SUPPORTING READ COUNT

Split reads = 17
Discordant mates = 1

— translocation — deletion
— duplication — inversion

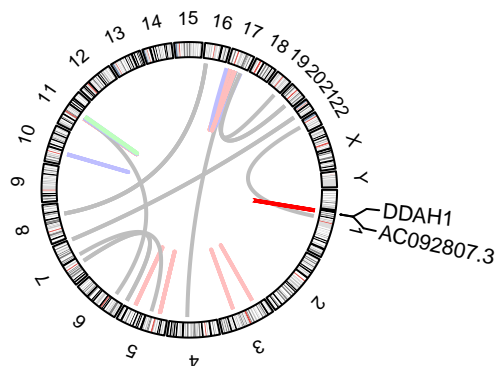
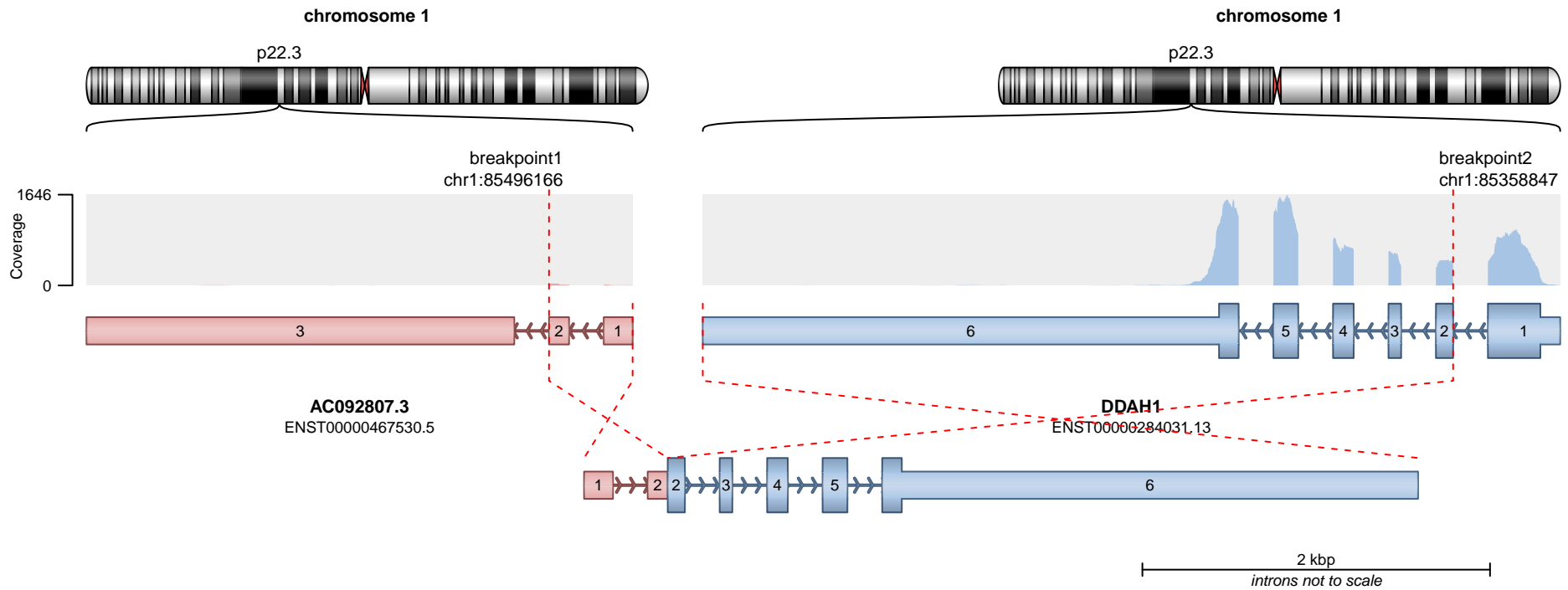

RETAINED PROTEIN DOMAINS
reading frame unclear

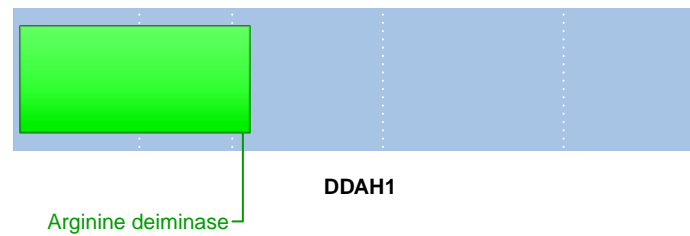

SUPPORTING READ COUNT

Split reads = 13
Discordant mates = 1

— translocation — deletion
— duplication — inversion

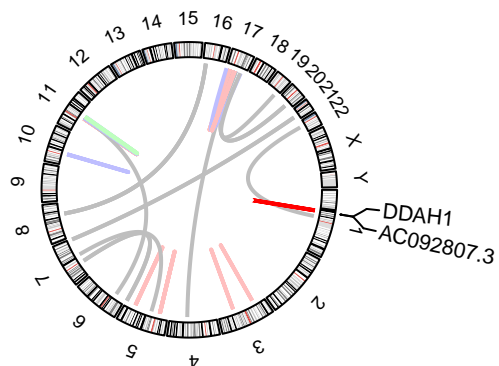
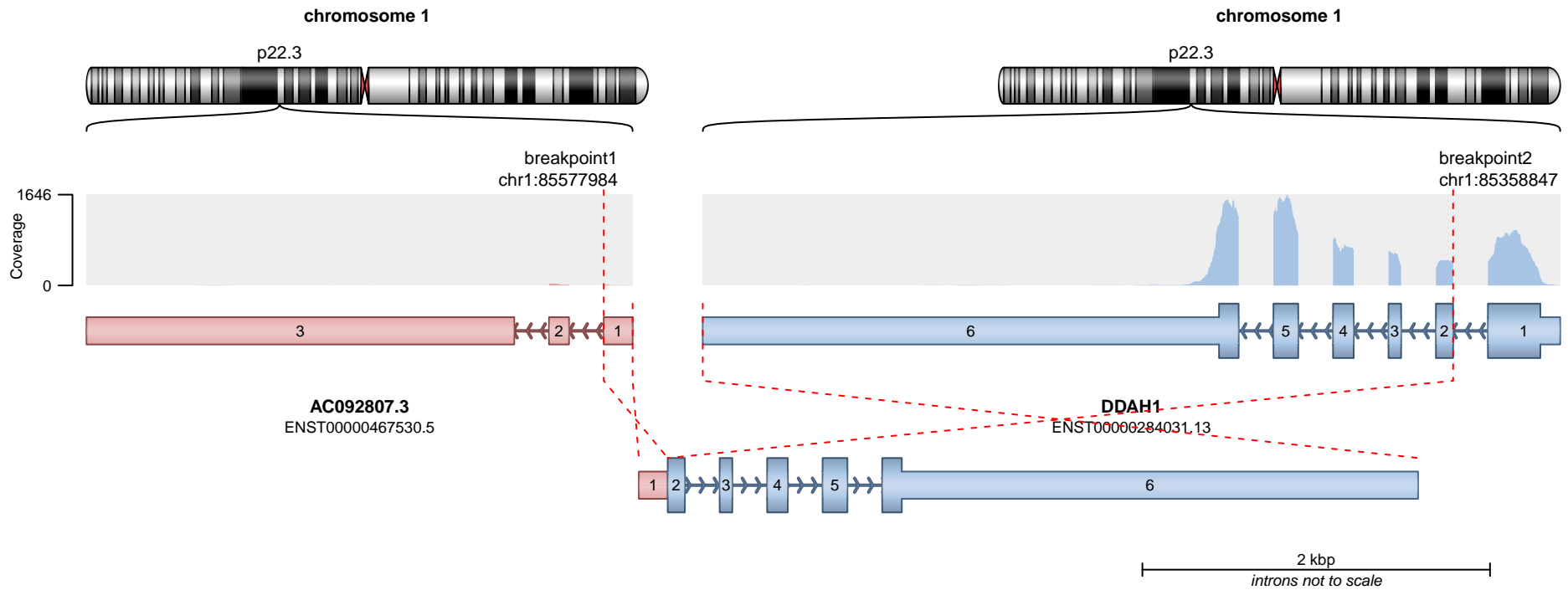

RETAINED PROTEIN DOMAINS
reading frame unclear

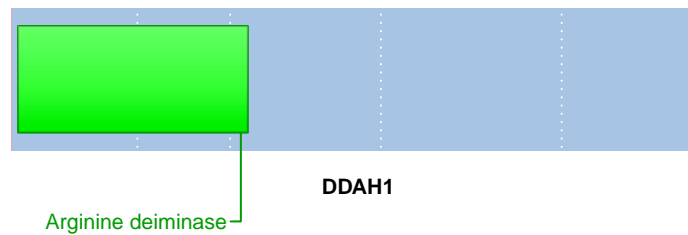

SUPPORTING READ COUNT

Split reads = 4
Discordant mates = 0

- translocation
- duplication
- deletion
- inversion