

**RETAINED PROTEIN DOMAINS**  
reading frame unclear

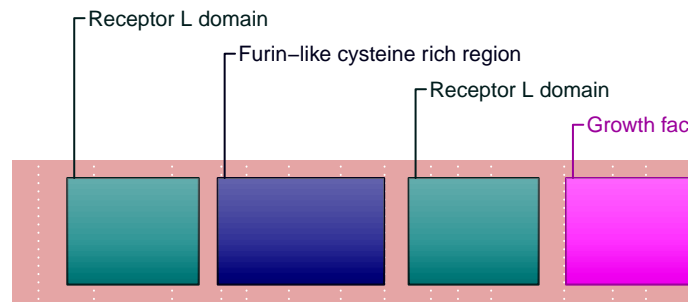

**ERBB2**

**SUPPORTING READ COUNT**

Split reads = 3525  
Discordant mates = 0

— translocation — deletion  
— duplication — inversion

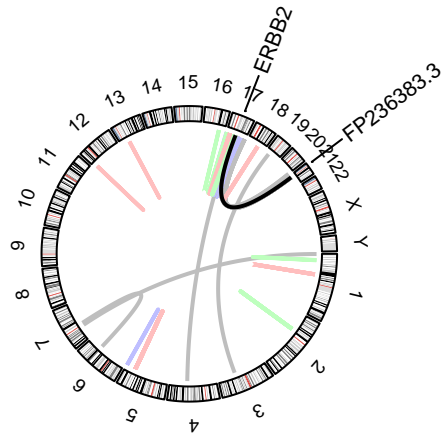
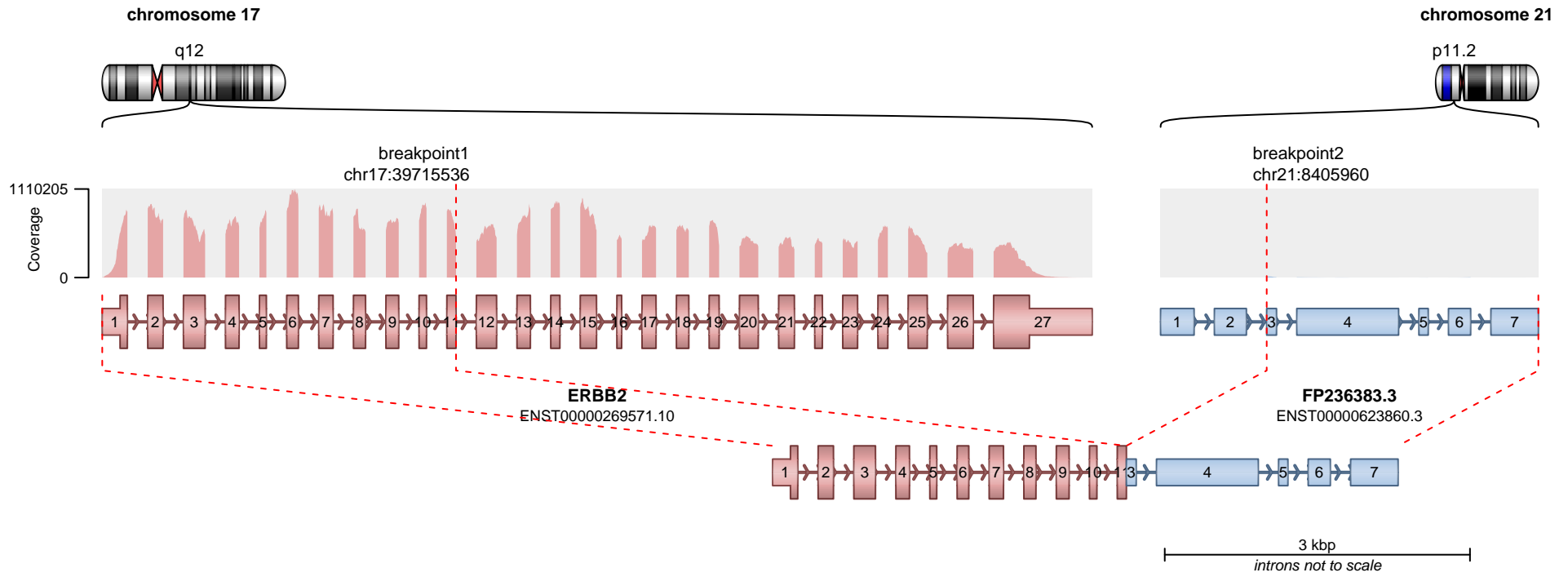

**RETAINED PROTEIN DOMAINS**  
reading frame unclear

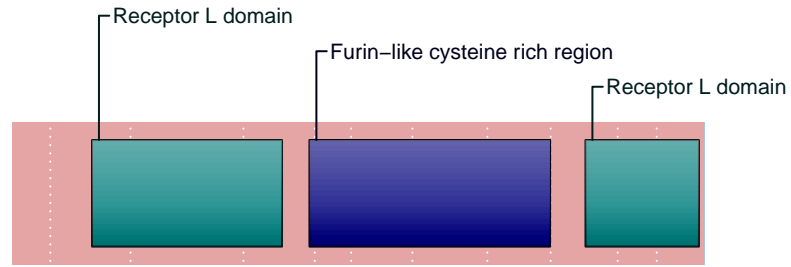

**ERBB2**

**SUPPORTING READ COUNT**

Split reads = 406  
Discordant mates = 0

— translocation — deletion  
— duplication — inversion

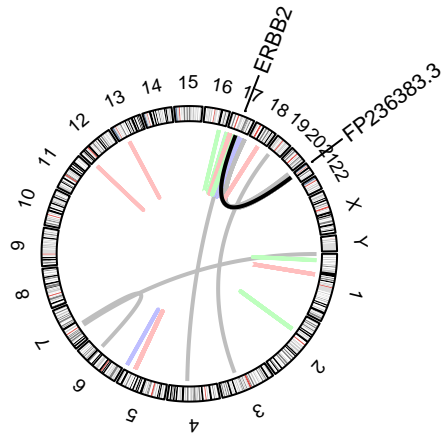
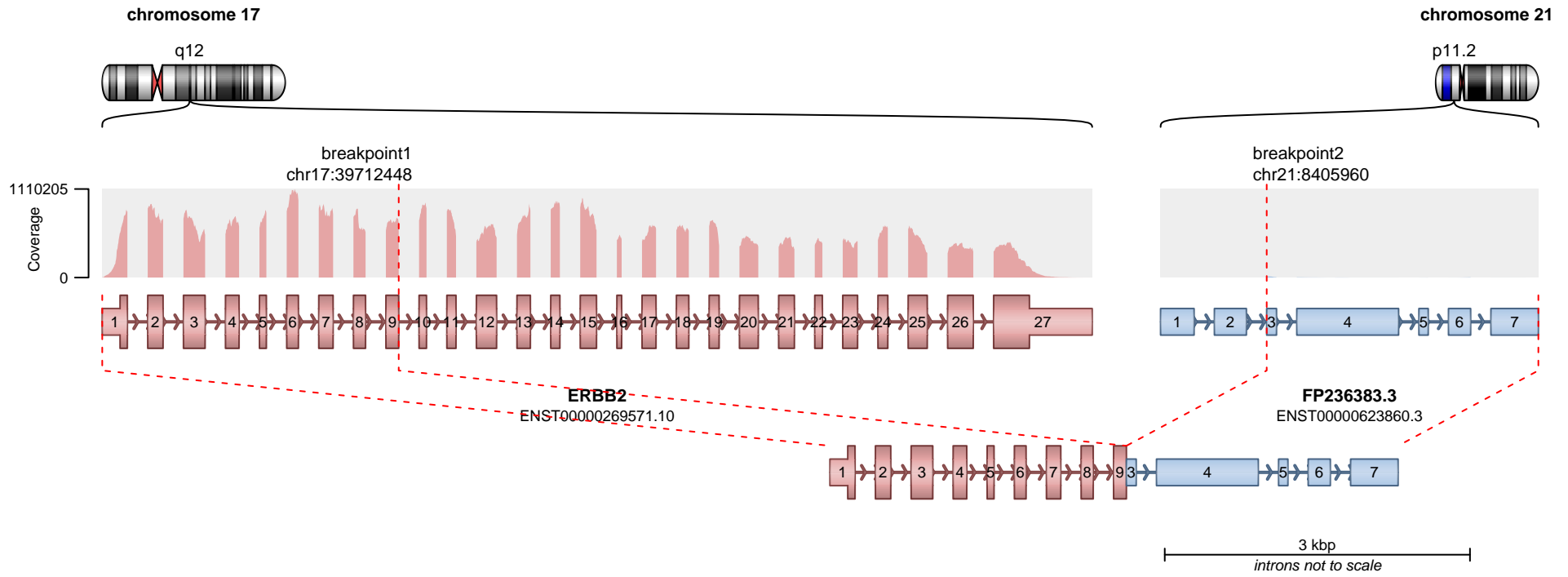

**RETAINED PROTEIN DOMAINS**  
reading frame unclear

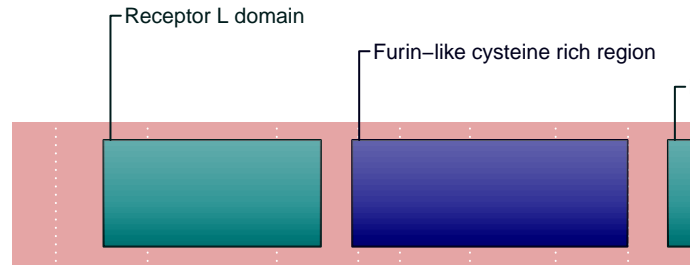

**ERBB2**

**SUPPORTING READ COUNT**

Split reads = 63  
Discordant mates = 0

- translocation
- duplication
- deletion
- inversion

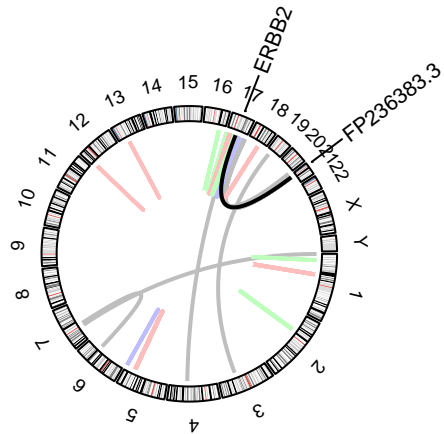
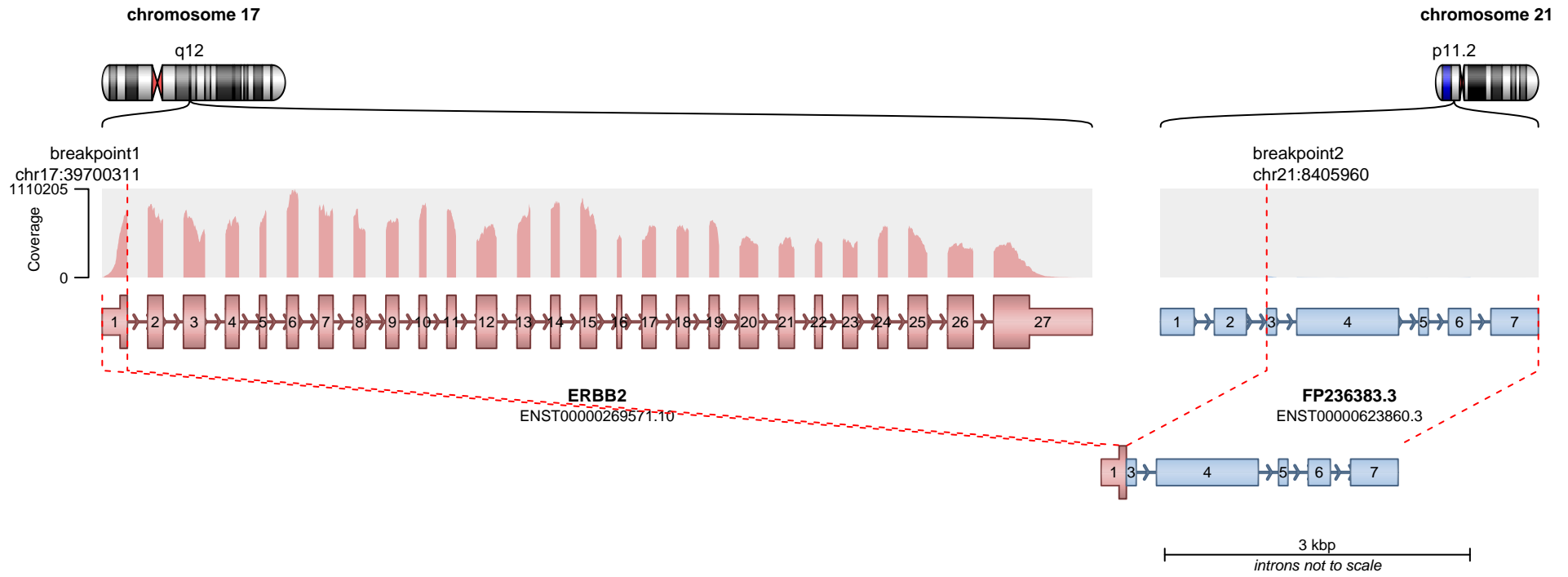

— translocation    — deletion  
— duplication    — inversion

No protein domains retained in fusion.

**SUPPORTING READ COUNT**

Split reads = 35  
Discordant mates = 0

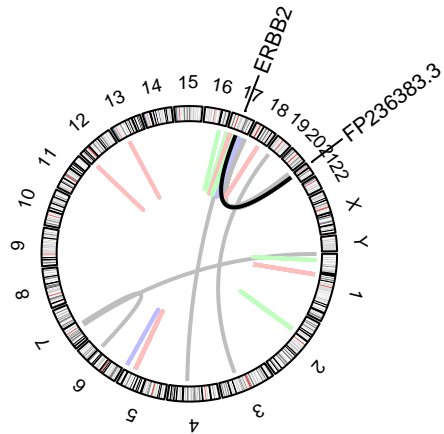
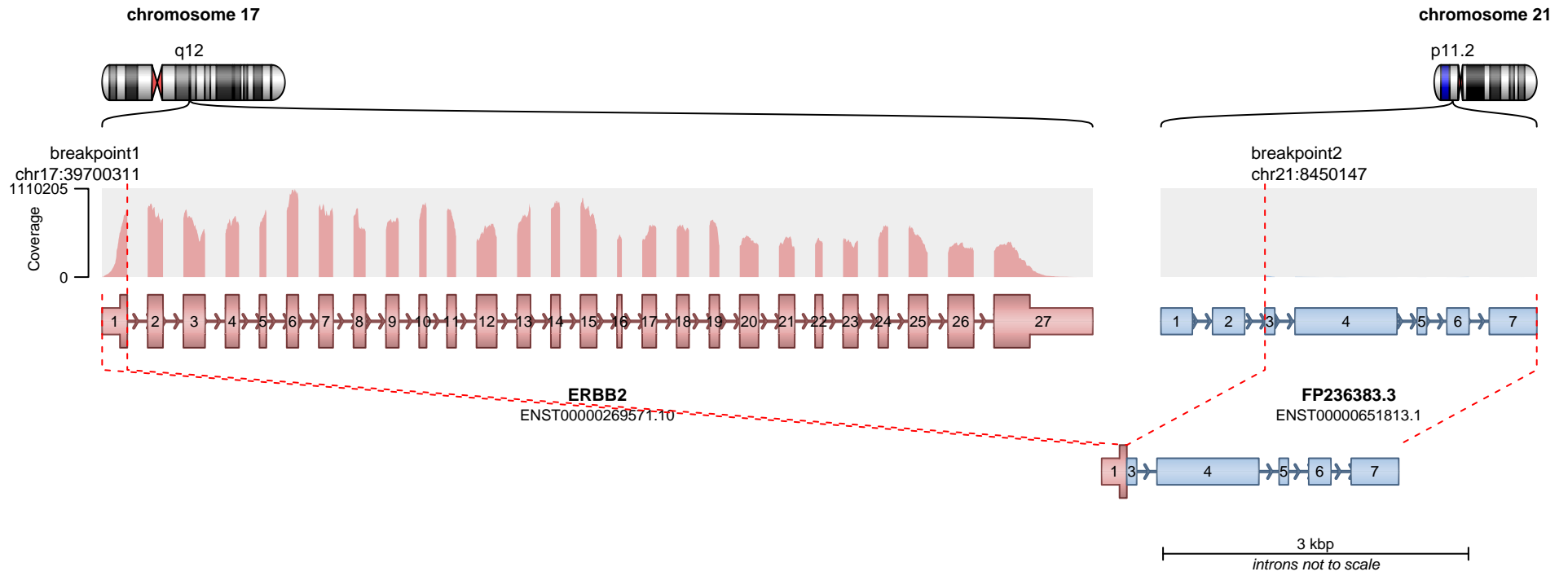

— translocation — deletion  
— duplication — inversion

No protein domains retained in fusion.

**SUPPORTING READ COUNT**

Split reads = 35  
Discordant mates = 0

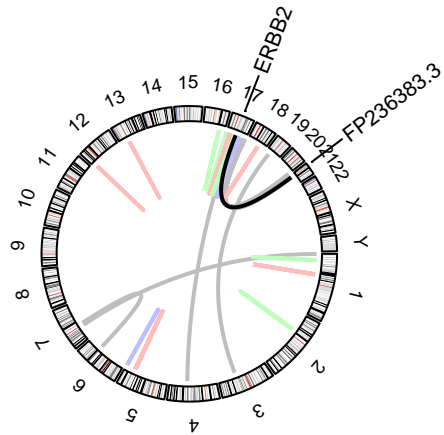
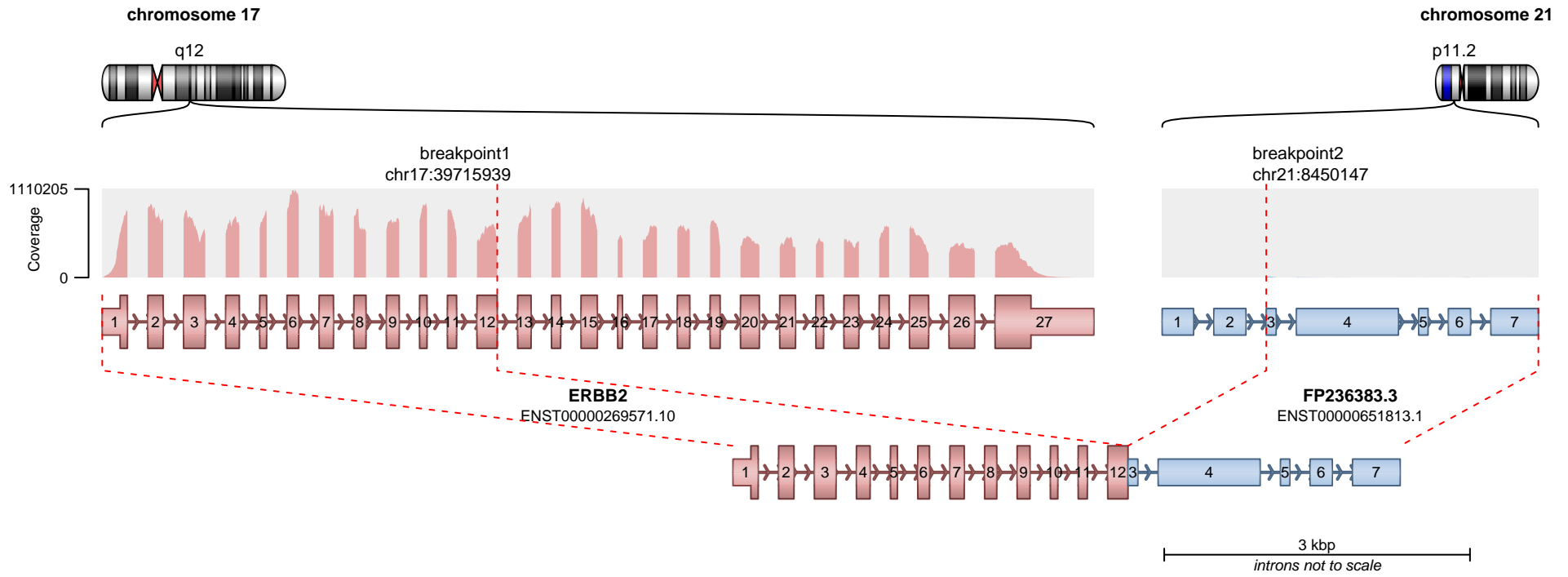

**RETAINED PROTEIN DOMAINS**  
reading frame unclear

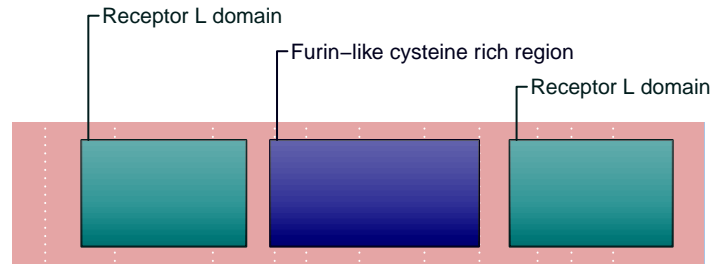

**ERBB2**

**SUPPORTING READ COUNT**

Split reads = 25  
Discordant mates = 0

- translocation
- duplication
- deletion
- inversion

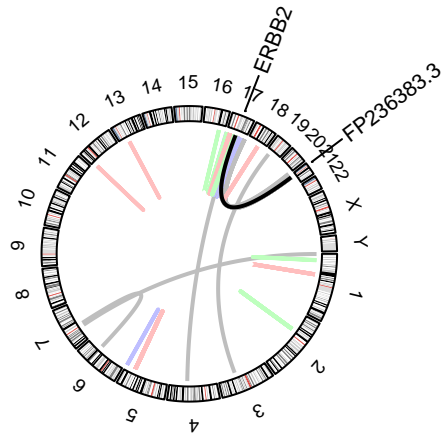
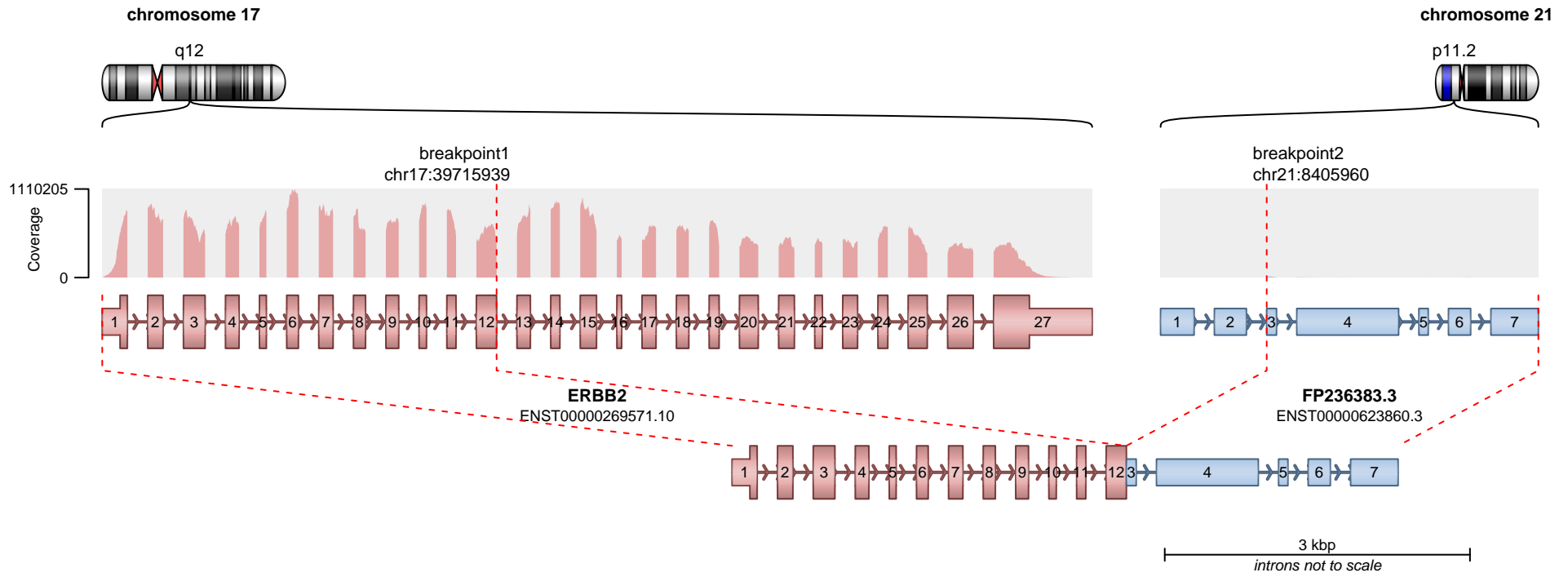

**RETAINED PROTEIN DOMAINS**  
reading frame unclear

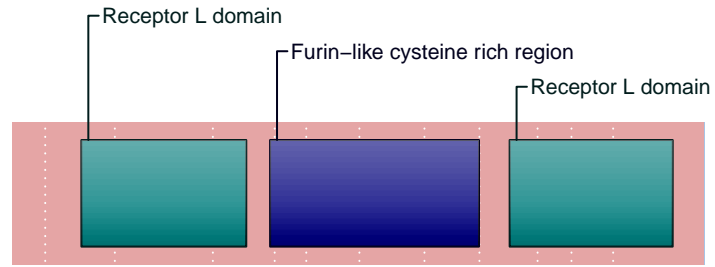

**ERBB2**

**SUPPORTING READ COUNT**

Split reads = 25  
Discordant mates = 0

— translocation — deletion  
— duplication — inversion

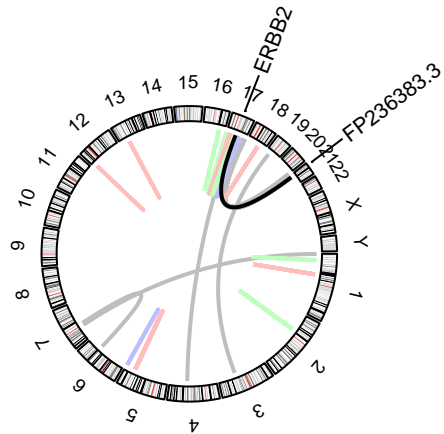
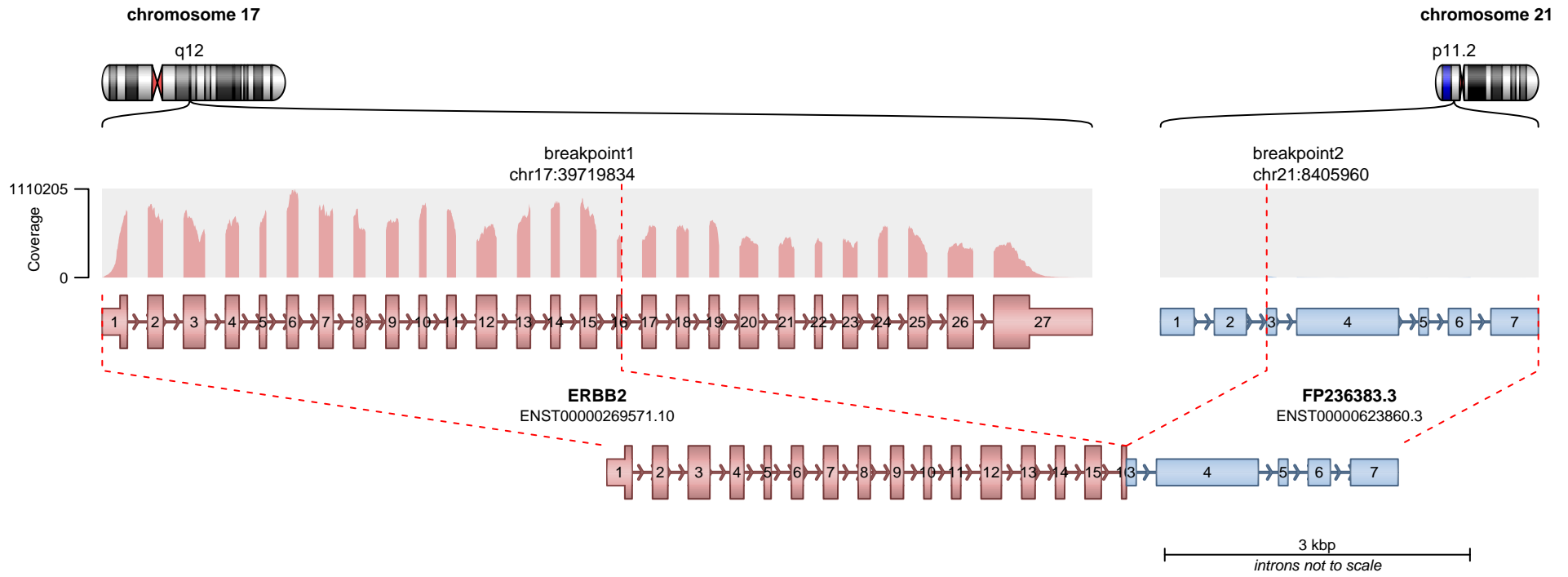

**RETAINED PROTEIN DOMAINS**  
reading frame unclear

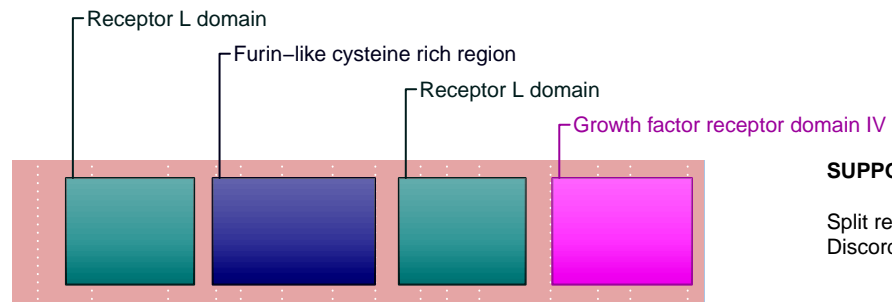

**SUPPORTING READ COUNT**

Split reads = 9  
Discordant mates = 0

**ERBB2**

- translocation
- duplication
- deletion
- inversion

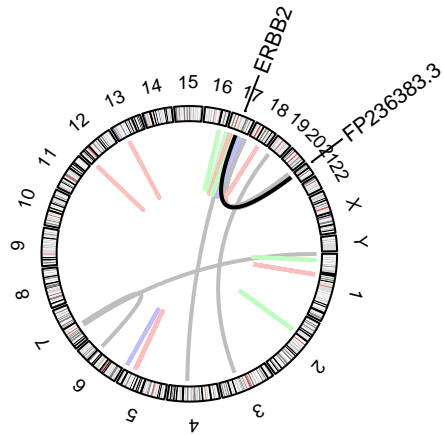
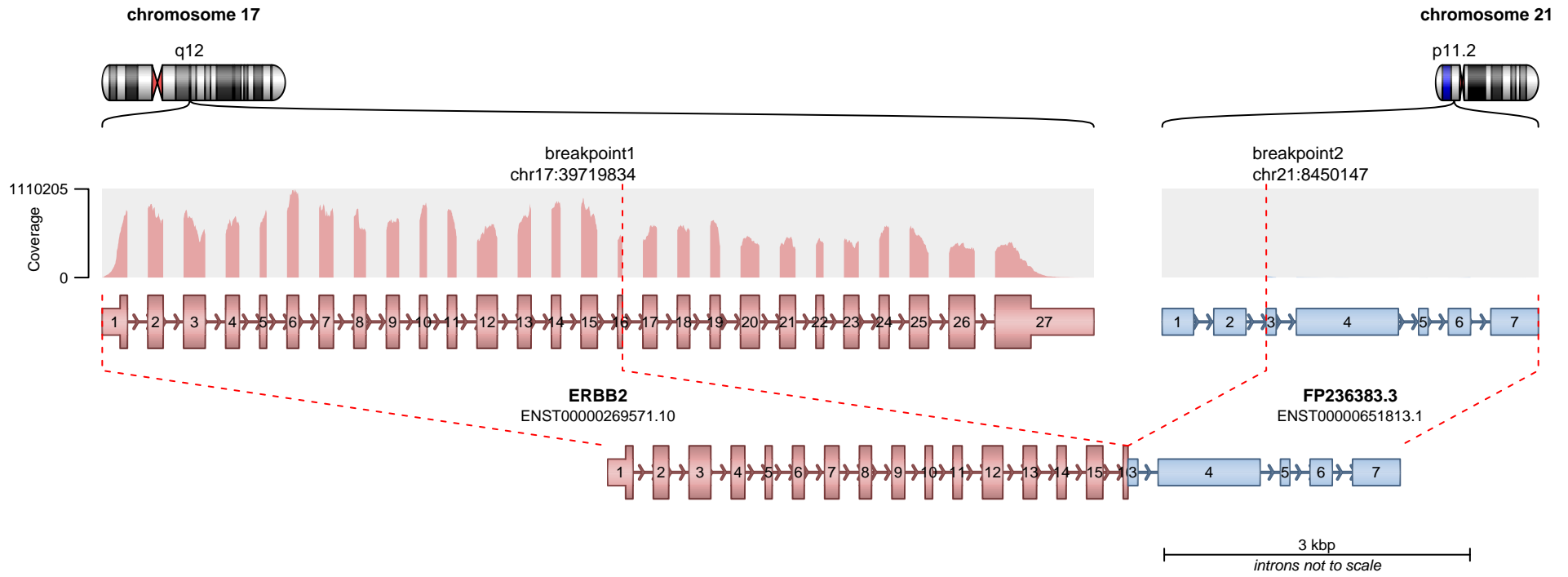

**RETAINED PROTEIN DOMAINS**  
reading frame unclear

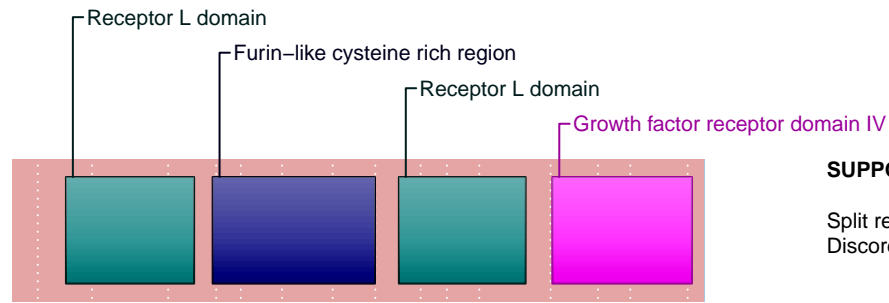

**ERBB2**

**SUPPORTING READ COUNT**

Split reads = 9  
Discordant mates = 0

— translocation    — deletion  
— duplication    — inversion

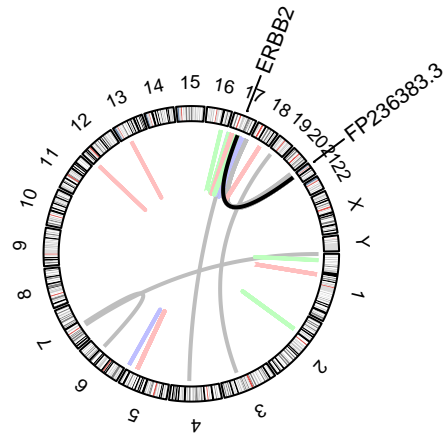
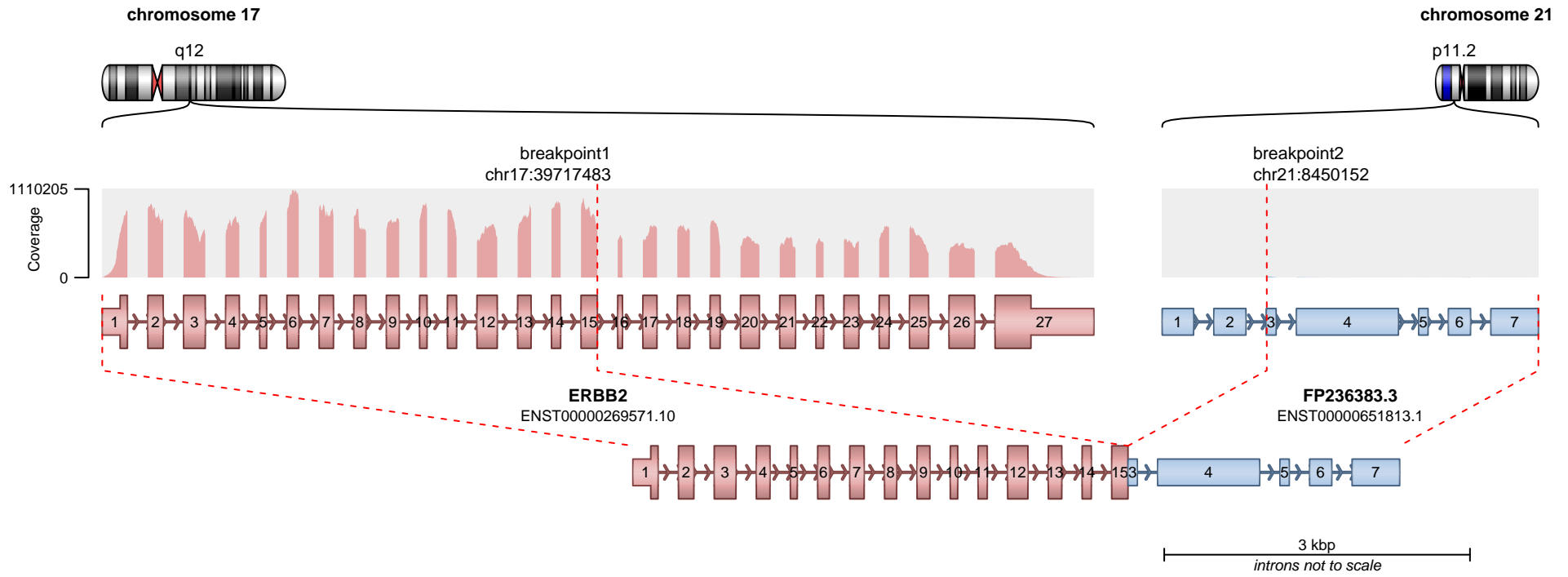

**RETAINED PROTEIN DOMAINS**  
reading frame unclear

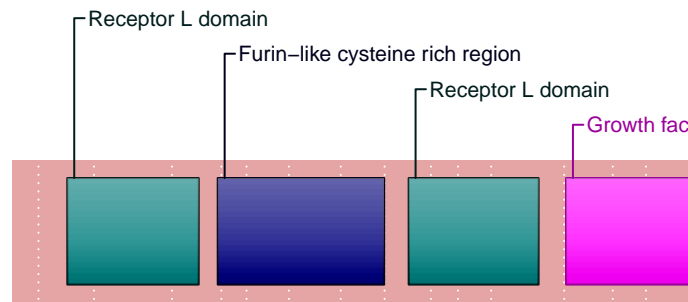

**SUPPORTING READ COUNT**

Split reads = 6  
Discordant mates = 0

— translocation    — deletion  
— duplication    — inversion

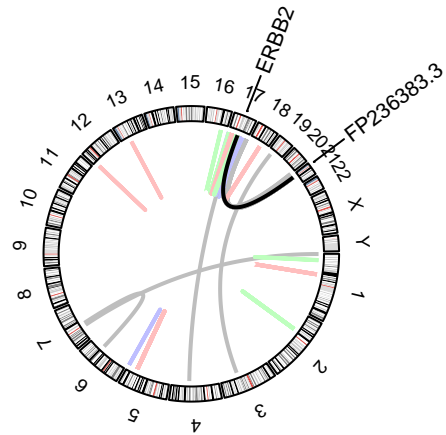
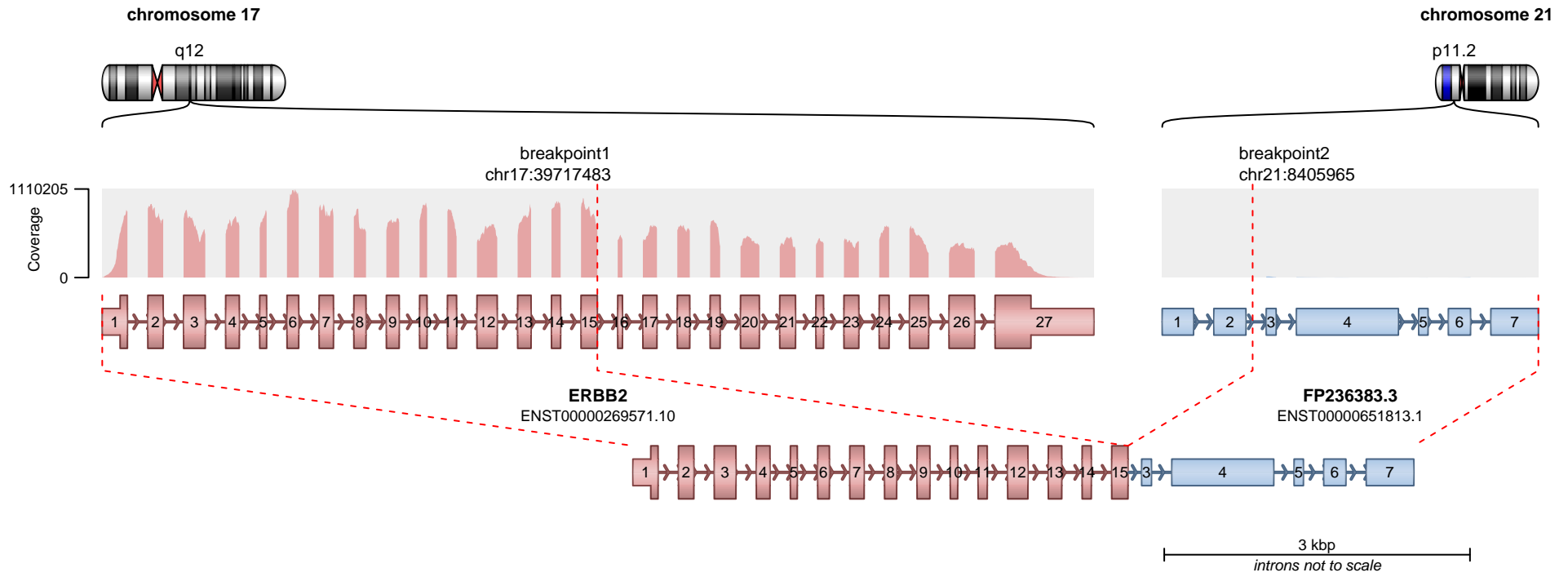

**RETAINED PROTEIN DOMAINS**  
reading frame unclear

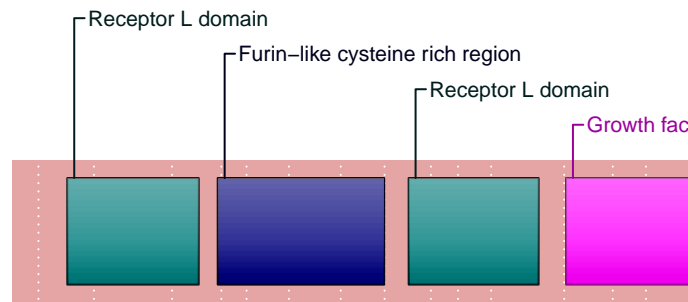

**ERBB2**

**SUPPORTING READ COUNT**

Split reads = 6  
Discordant mates = 0

— translocation — deletion  
— duplication — inversion

chromosome 21

p11.2

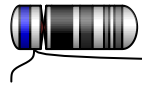

chromosome 17

q12

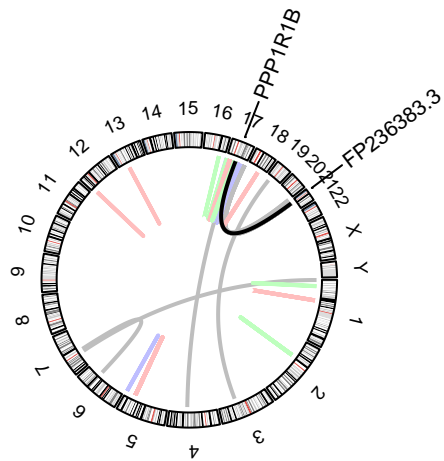
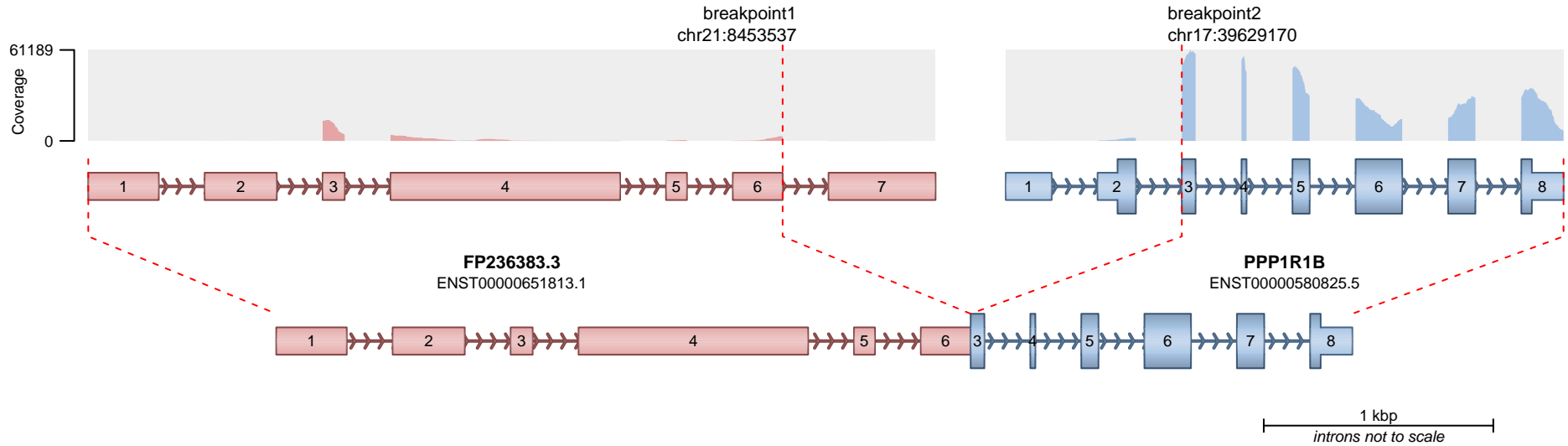
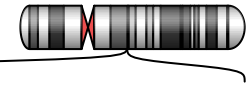

RETAINED PROTEIN DOMAINS  
reading frame unclear



PPP1R1B

Protein phosphatase inhibitor 1/DARPP-32

SUPPORTING READ COUNT

Split reads = 1605  
Discordant mates = 0

— translocation    — deletion  
— duplication    — inversion

chromosome 21

p11.2

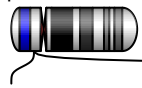

chromosome 17

q12

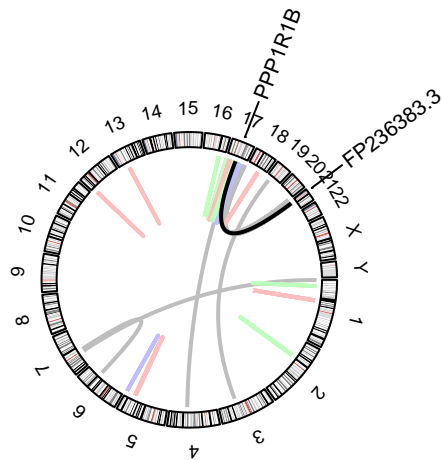
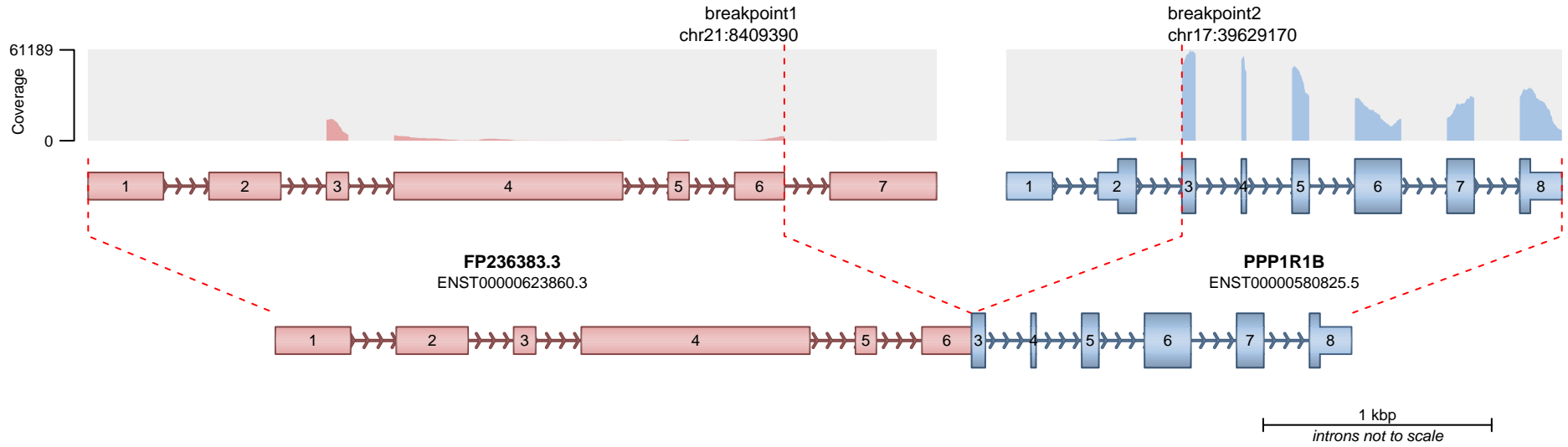
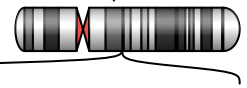

RETAINED PROTEIN DOMAINS  
reading frame unclear

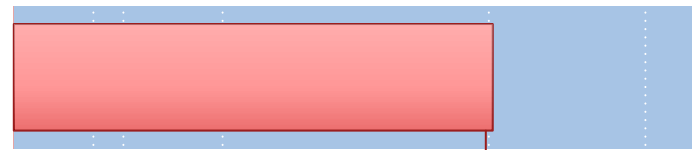

**PPP1R1B**

Protein phosphatase inhibitor 1/DARPP-32

**SUPPORTING READ COUNT**

Split reads = 1604  
Discordant mates = 0

— translocation    — deletion  
— duplication    — inversion

chromosome 21

p11.2

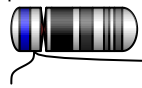

chromosome 17

q12

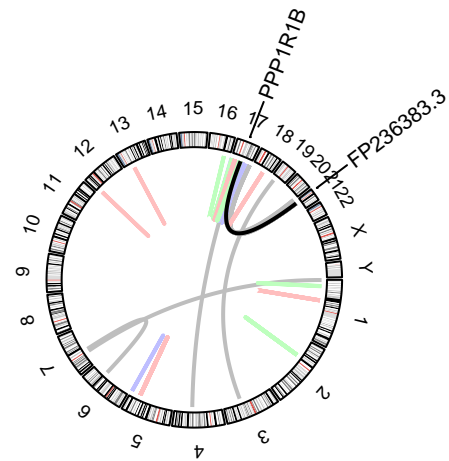
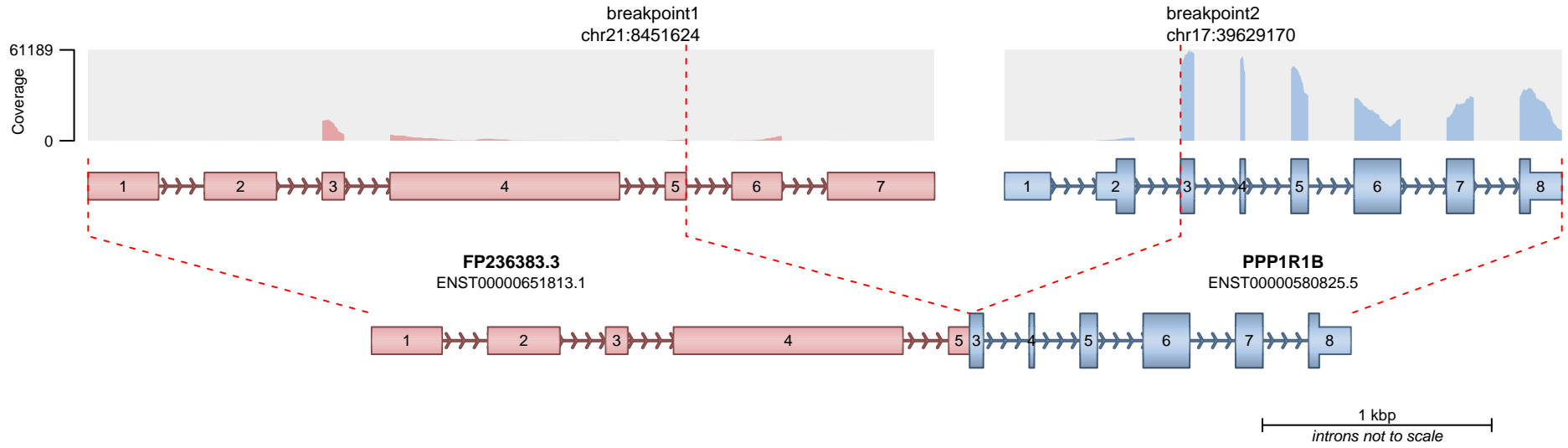
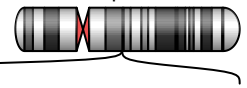

RETAINED PROTEIN DOMAINS  
reading frame unclear



PPP1R1B

Protein phosphatase inhibitor 1/DARPP-32

SUPPORTING READ COUNT

Split reads = 263  
Discordant mates = 0

- translocation
- duplication
- deletion
- inversion

chromosome 21

p11.2

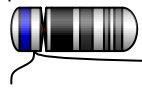

chromosome 17

q12

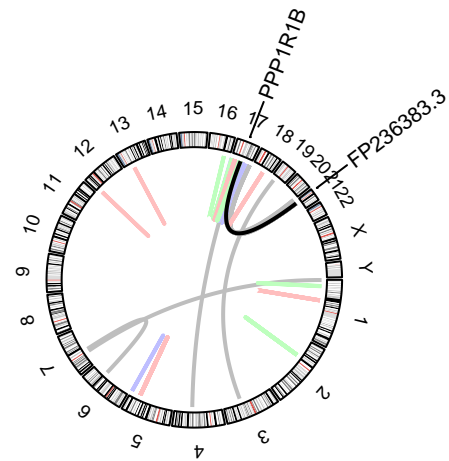
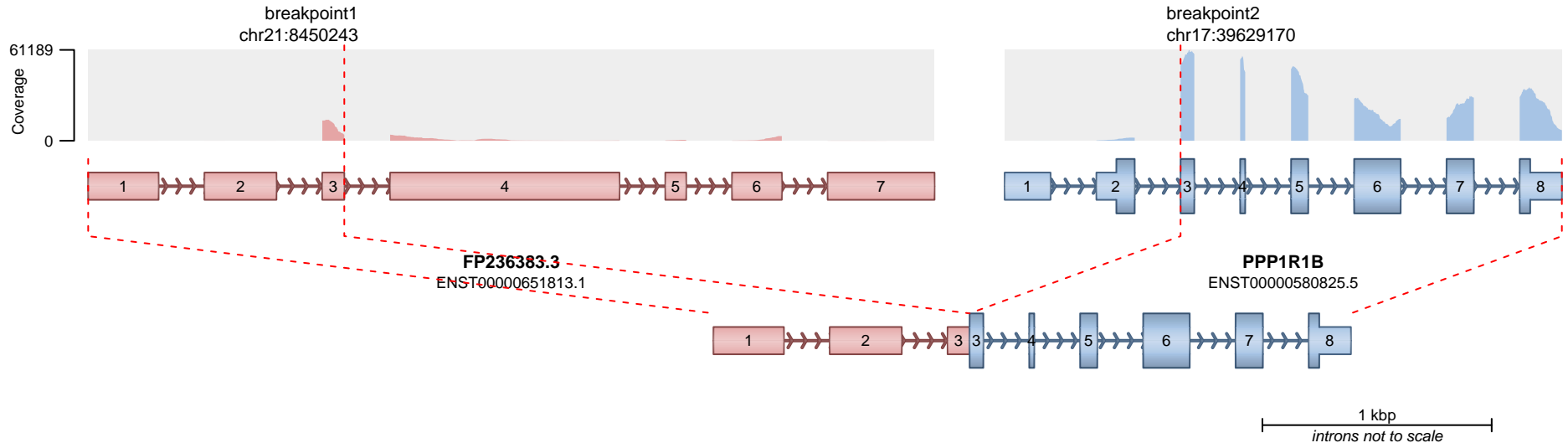
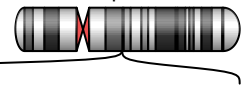

RETAINED PROTEIN DOMAINS  
reading frame unclear



PPP1R1B

Protein phosphatase inhibitor 1/DARPP-32

SUPPORTING READ COUNT

Split reads = 16  
Discordant mates = 0

— translocation    — deletion  
— duplication    — inversion

chromosome 21

p11.2



chromosome 17

q12

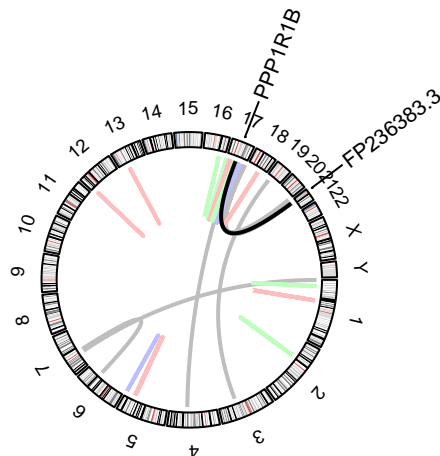
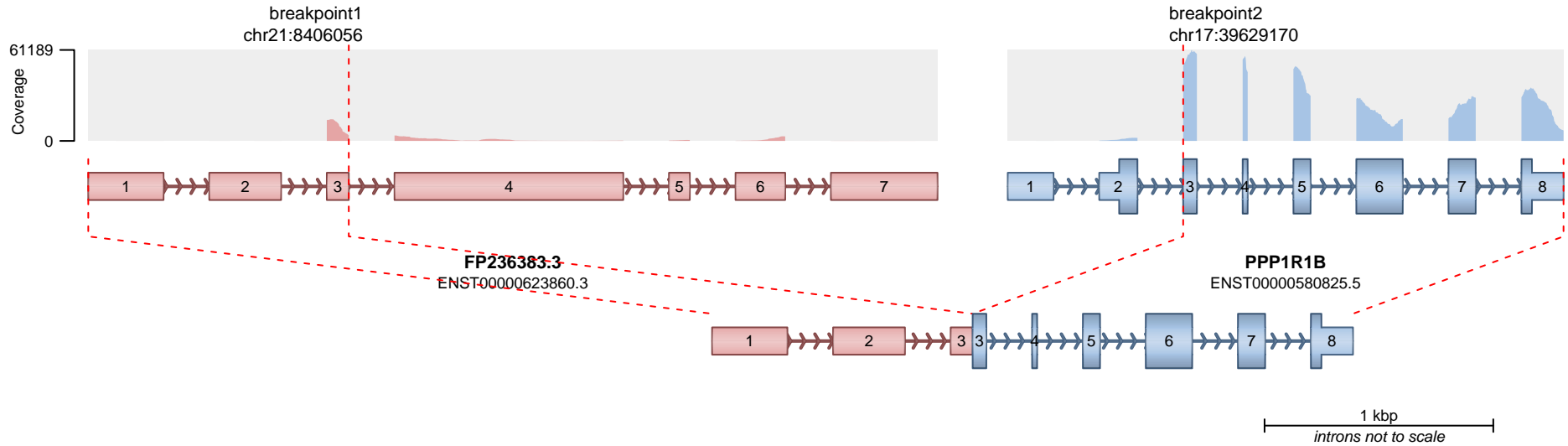
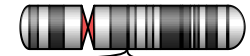

RETAINED PROTEIN DOMAINS  
reading frame unclear

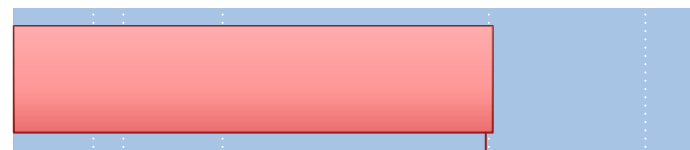

**PPP1R1B**

Protein phosphatase inhibitor 1/DARPP-32

**SUPPORTING READ COUNT**

Split reads = 16  
Discordant mates = 0

— translocation    — deletion  
— duplication    — inversion

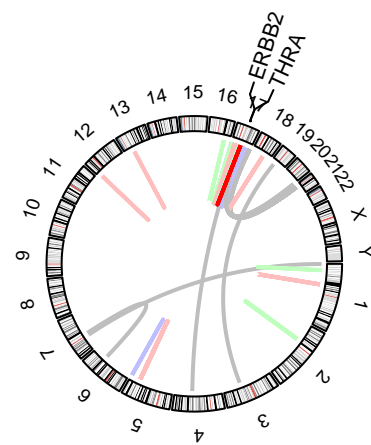
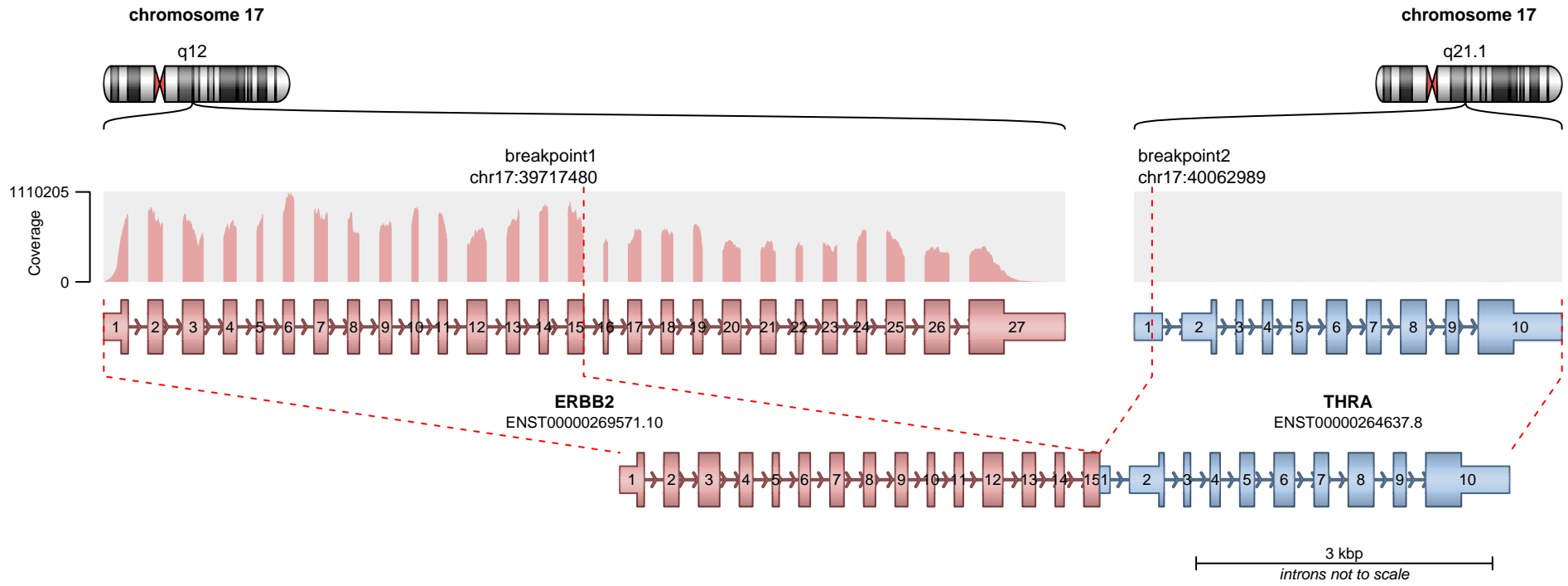

**RETAINED PROTEIN DOMAINS**  
reading frame unclear

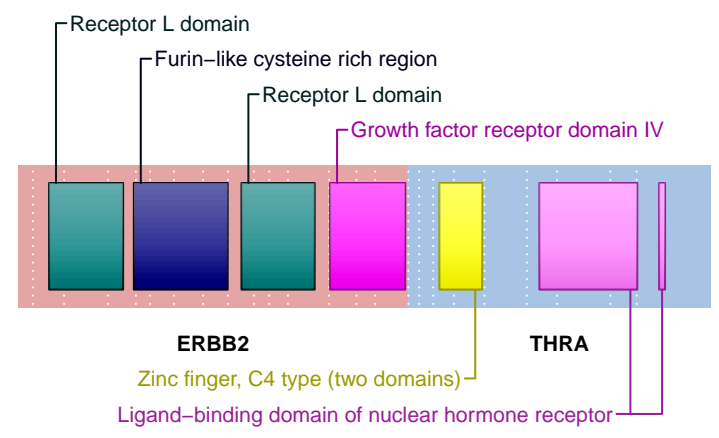

**SUPPORTING READ COUNT**

Split reads = 736  
Discordant mates = 0

- translocation
- duplication
- deletion
- inversion

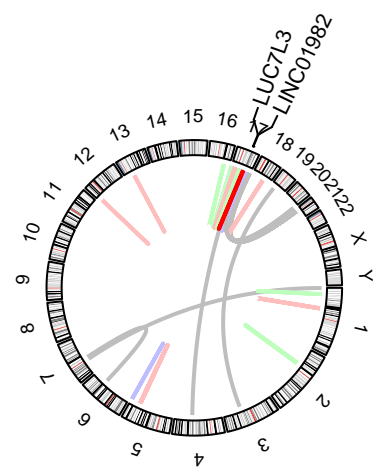
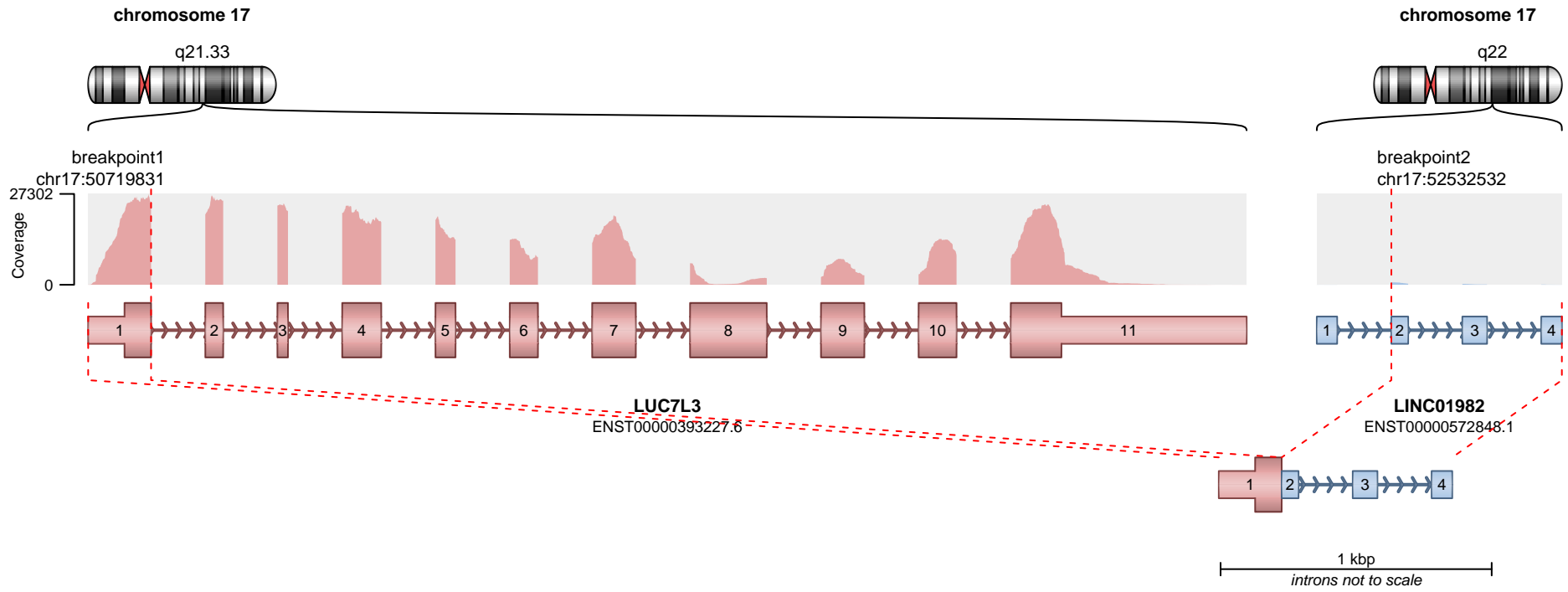

**RETAINED PROTEIN DOMAINS**  
reading frame unclear

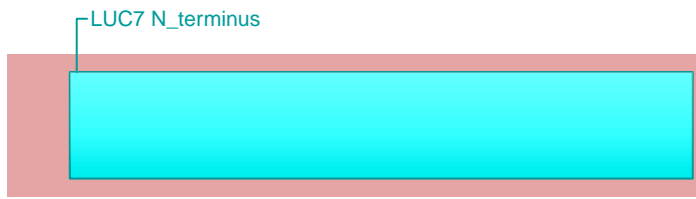

**SUPPORTING READ COUNT**

Split reads = 396  
Discordant mates = 10

— translocation — deletion  
— duplication — inversion

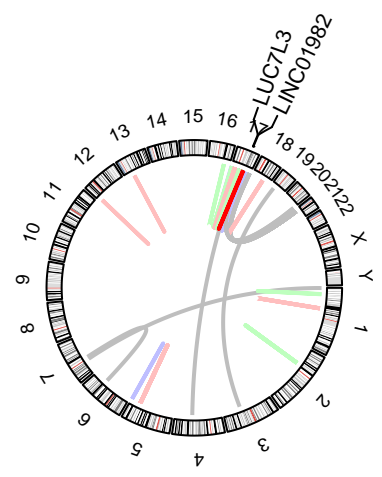
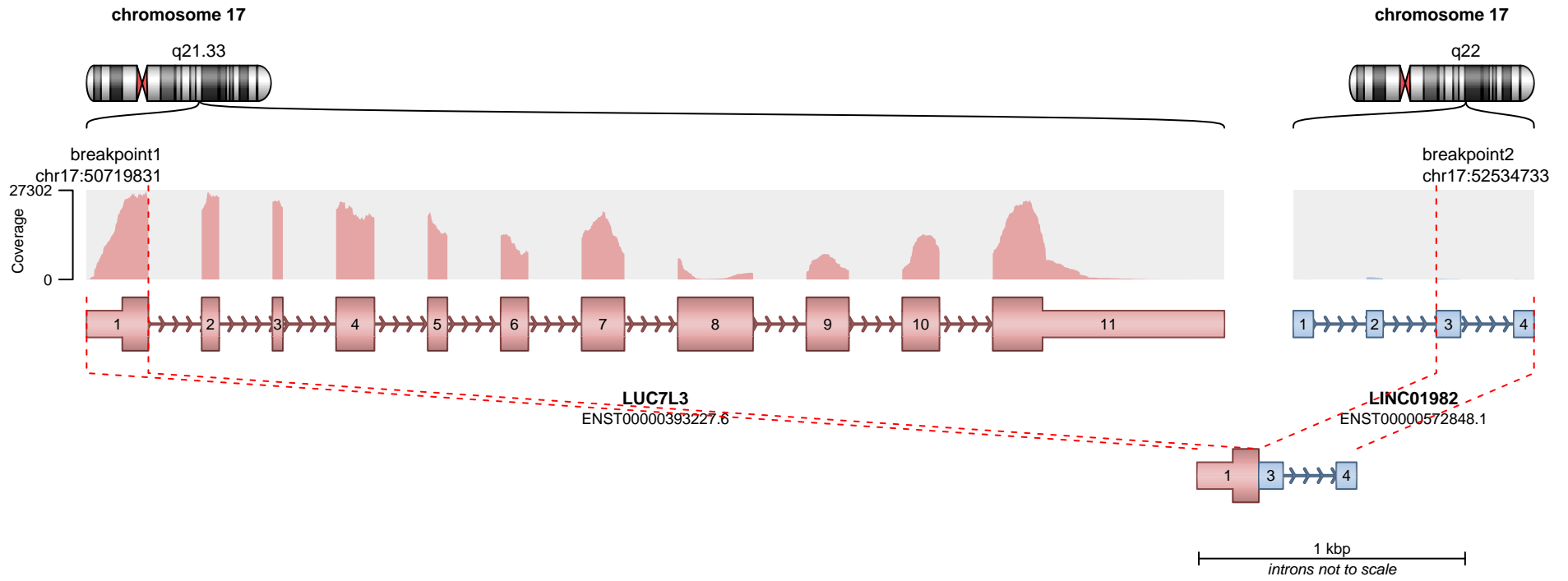

**RETAINED PROTEIN DOMAINS**  
reading frame unclear

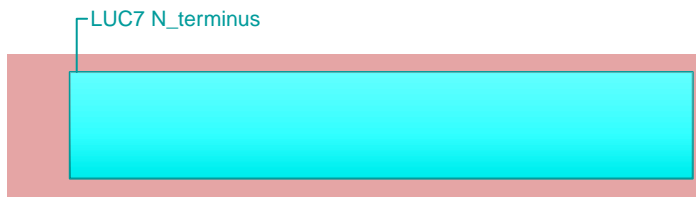

**SUPPORTING READ COUNT**

Split reads = 24  
Discordant mates = 3

- translocation
- duplication
- deletion
- inversion

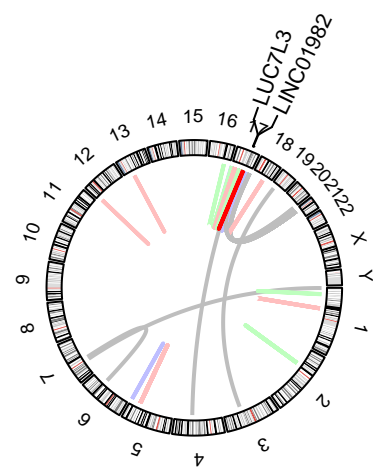
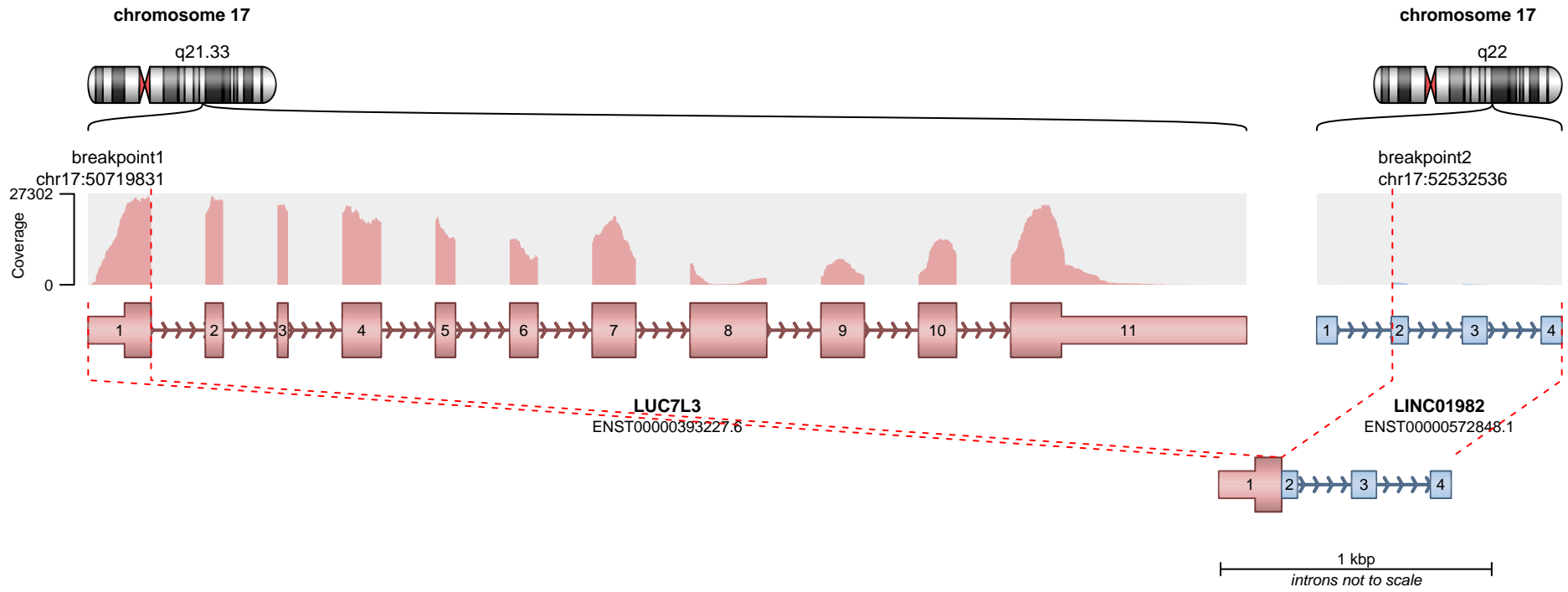

**RETAINED PROTEIN DOMAINS**  
reading frame unclear

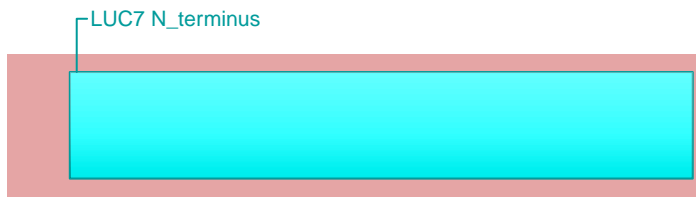

**LUC7L3**

**SUPPORTING READ COUNT**

Split reads = 5  
Discordant mates = 10

- translocation
- duplication
- deletion
- inversion

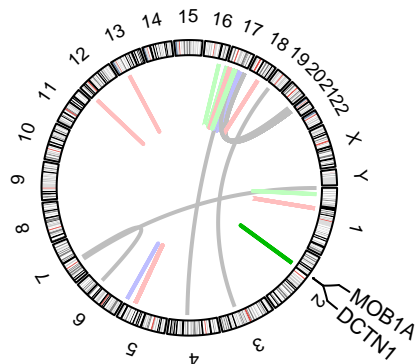
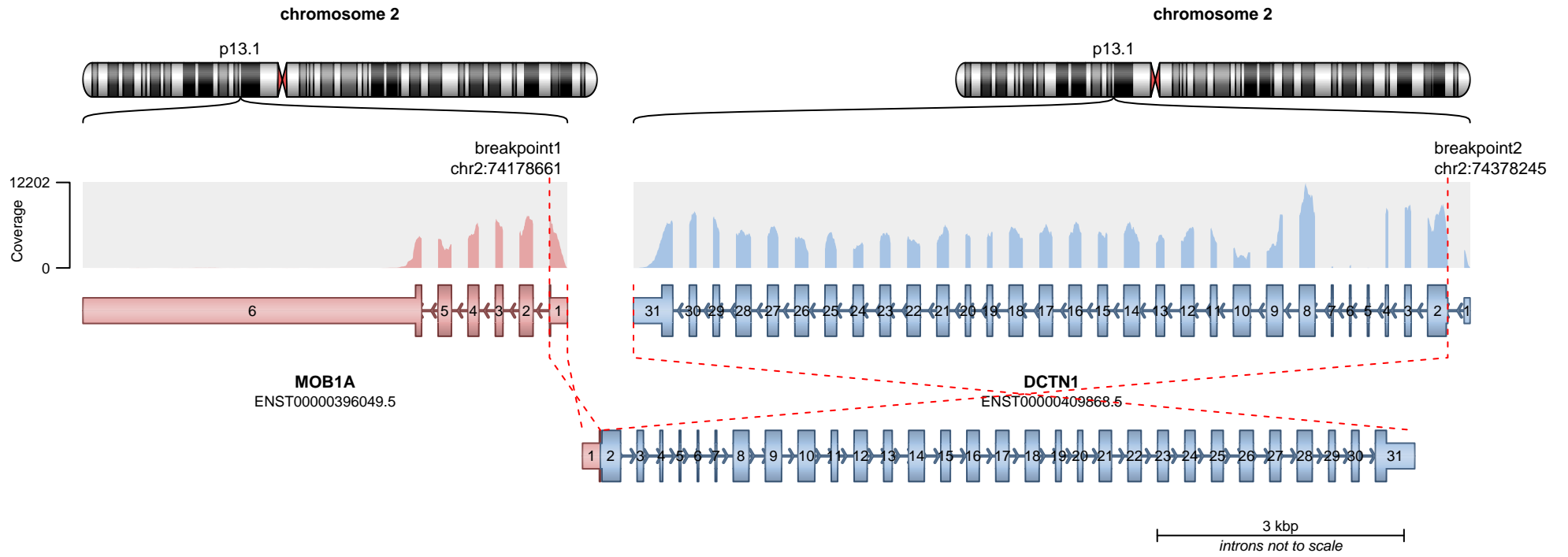

**RETAINED PROTEIN DOMAINS**  
reading frame unclear

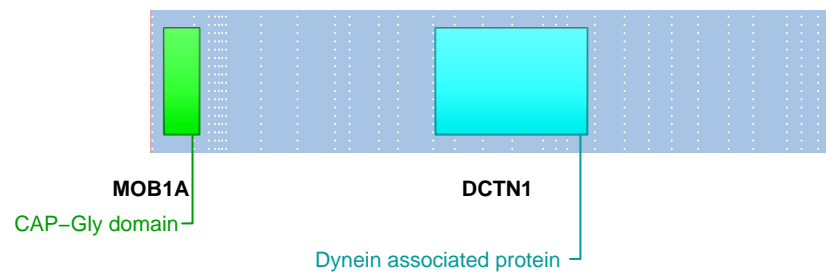

**SUPPORTING READ COUNT**

Split reads = 386  
Discordant mates = 16

- translocation
- duplication
- deletion
- inversion

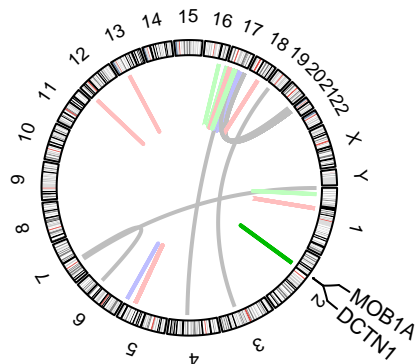
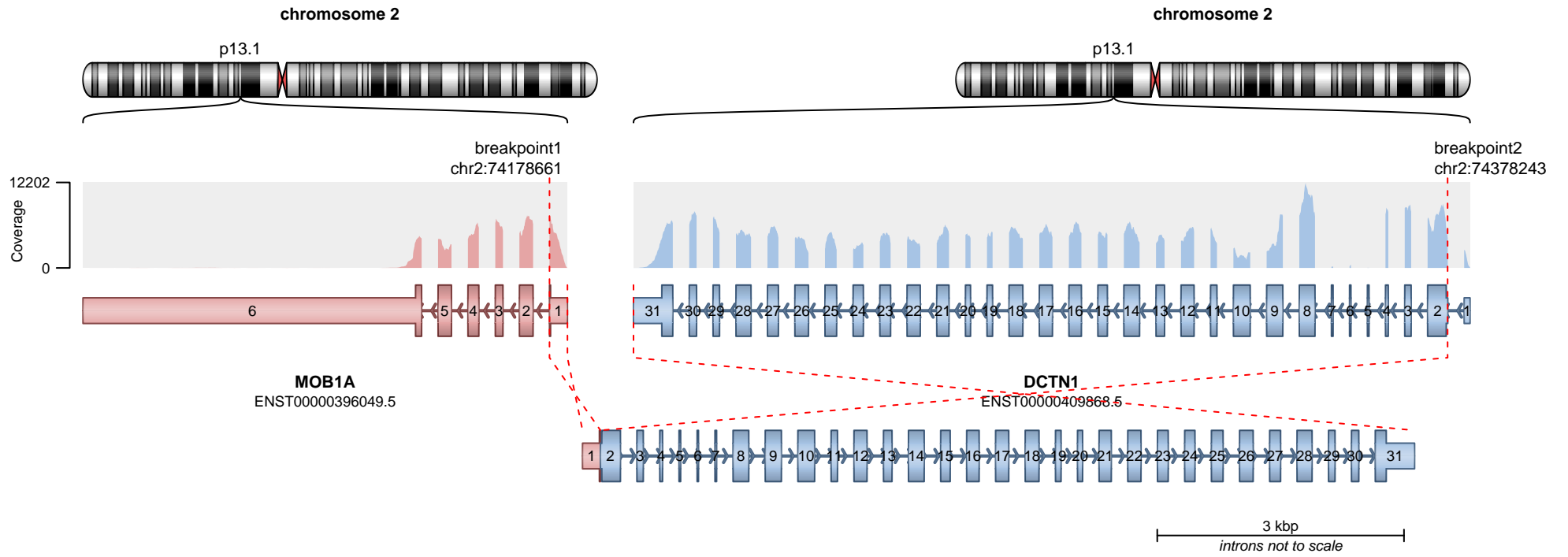

**RETAINED PROTEIN DOMAINS**  
reading frame unclear

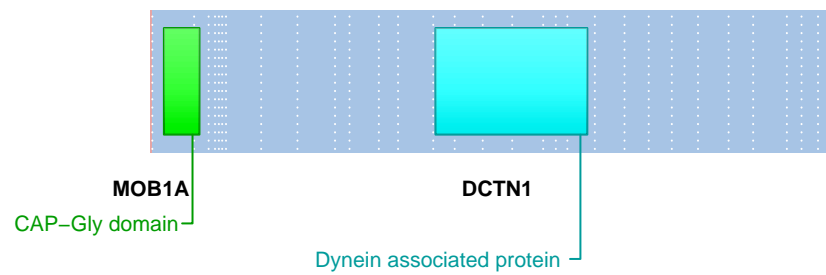

**SUPPORTING READ COUNT**

Split reads = 6  
Discordant mates = 16

- translocation
- duplication
- deletion
- inversion

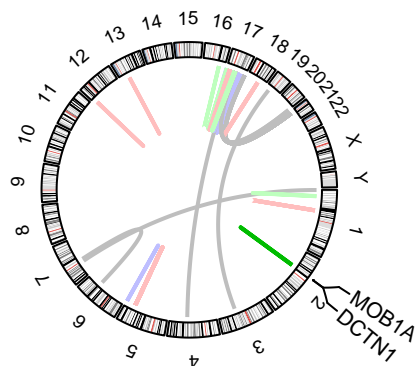
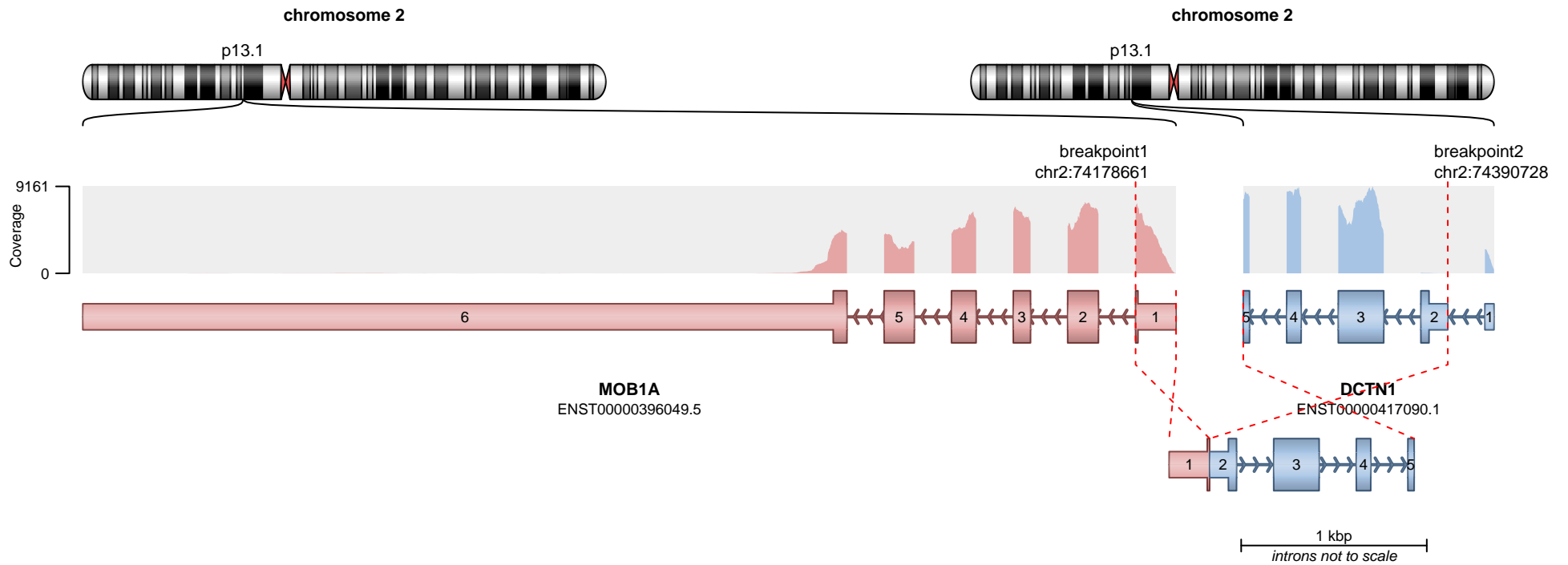

**RETAINED PROTEIN DOMAINS**  
reading frame unclear

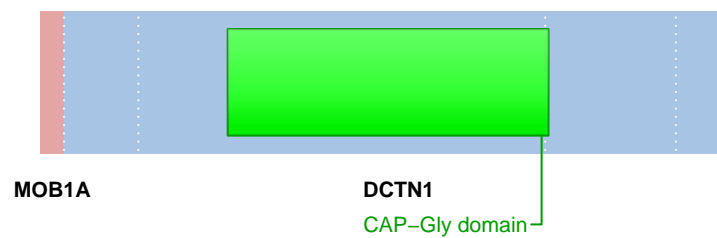

**SUPPORTING READ COUNT**

Split reads = 1  
Discordant mates = 16

- translocation
- duplication
- deletion
- inversion

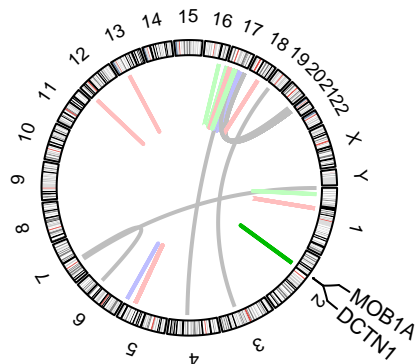
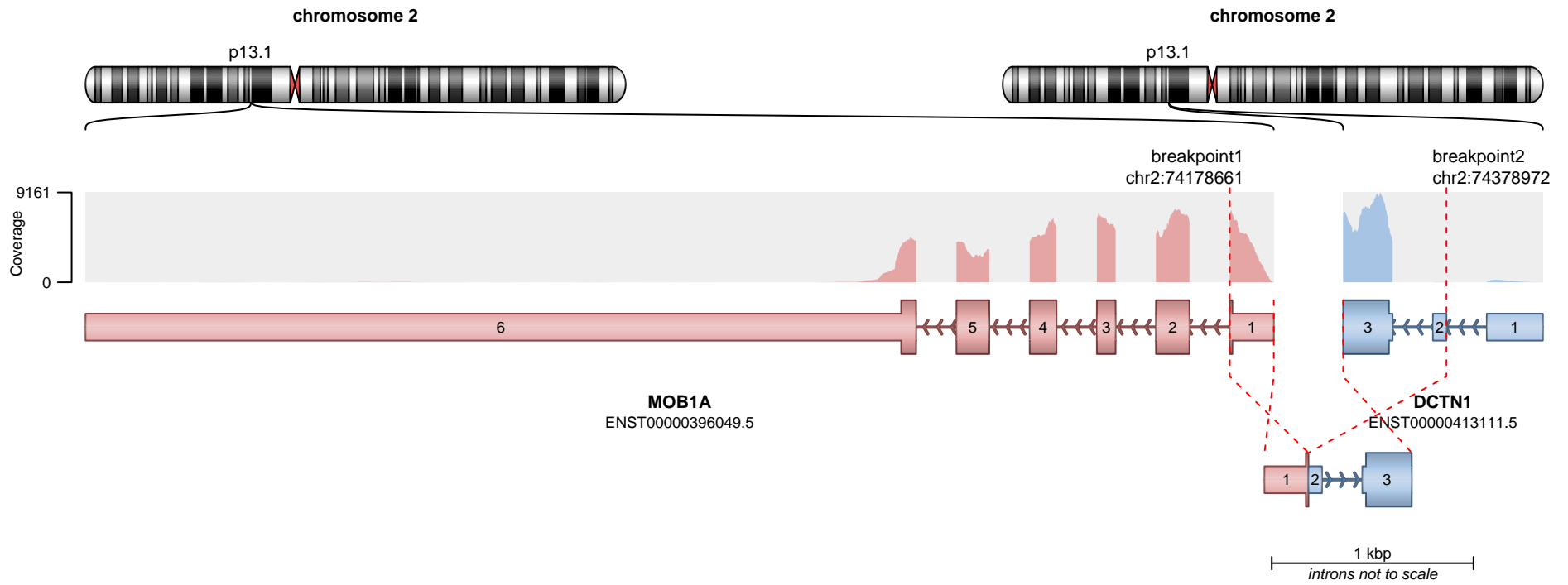

**RETAINED PROTEIN DOMAINS**  
reading frame unclear

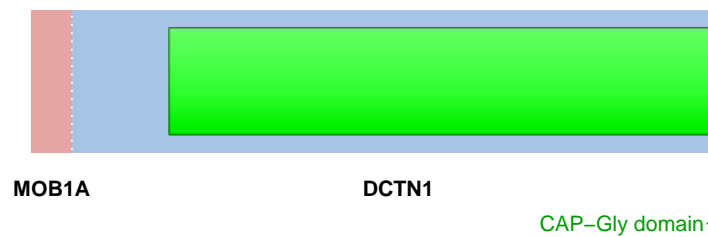

**SUPPORTING READ COUNT**

Split reads = 1  
Discordant mates = 16

- translocation
- duplication
- deletion
- inversion

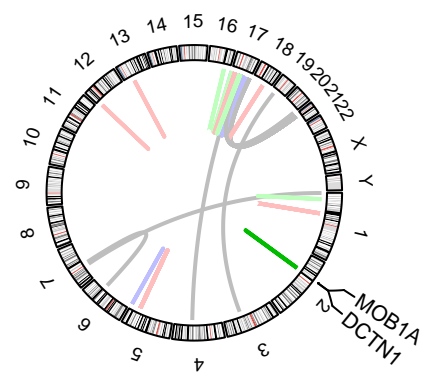
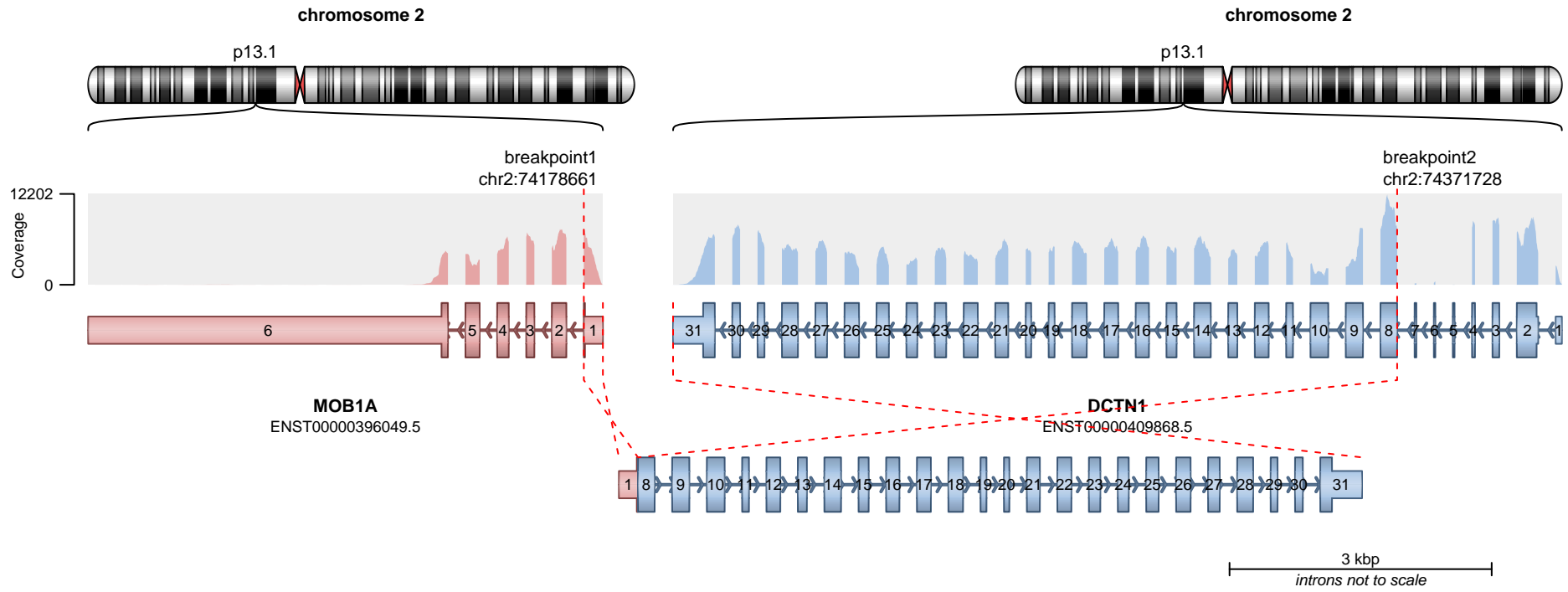

**RETAINED PROTEIN DOMAINS**  
reading frame unclear

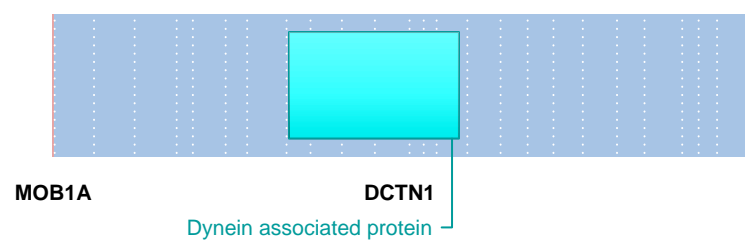

**SUPPORTING READ COUNT**

Split reads = 4  
Discordant mates = 0

- translocation
- duplication
- deletion
- inversion

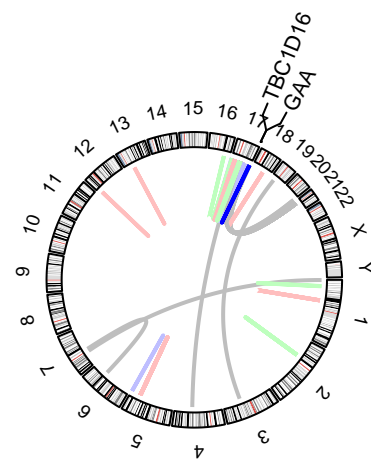
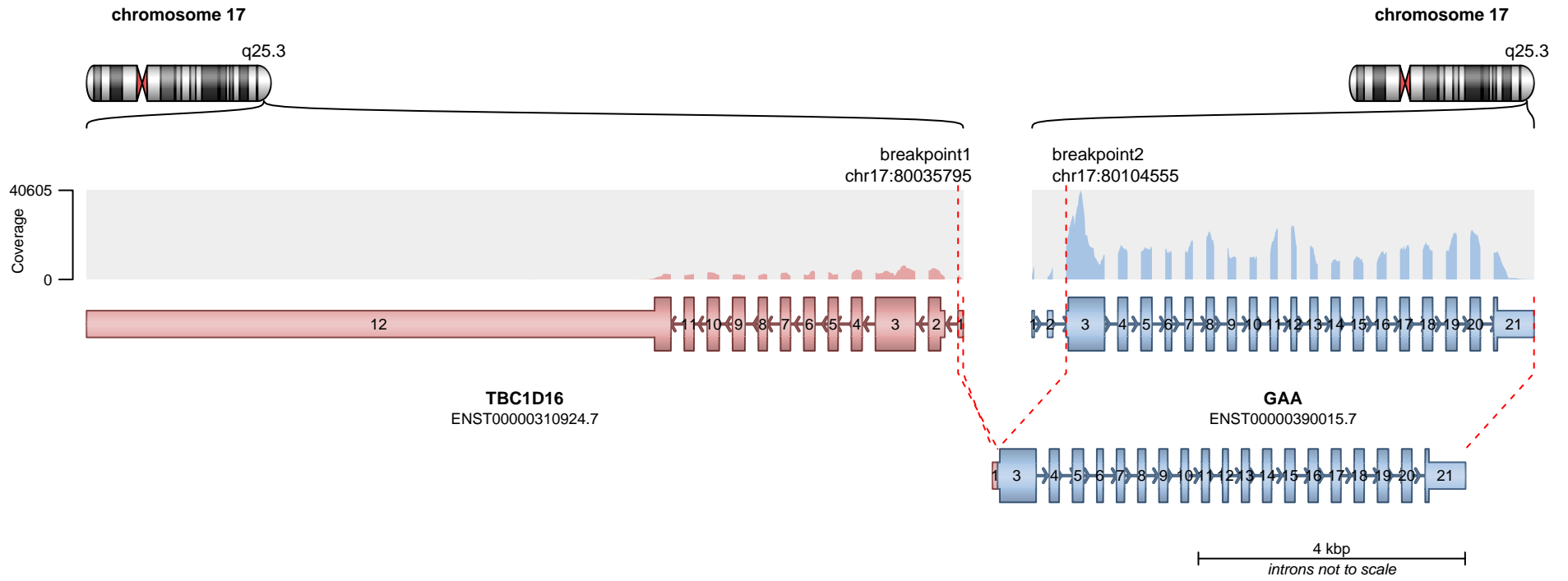

**RETAINED PROTEIN DOMAINS**  
reading frame unclear

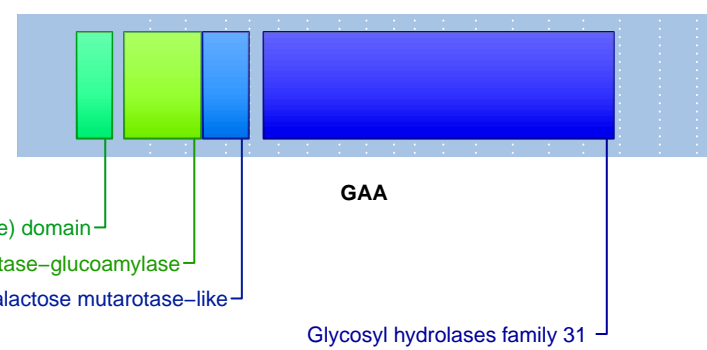

**SUPPORTING READ COUNT**

Split reads = 302  
Discordant mates = 0

- translocation
- duplication
- deletion
- inversion

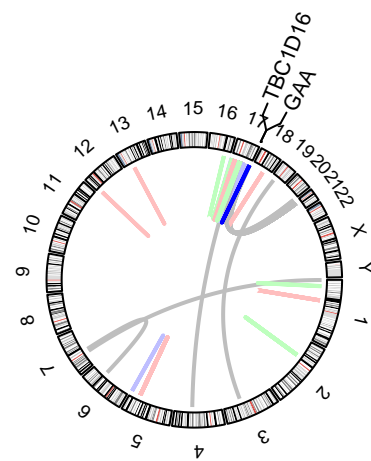
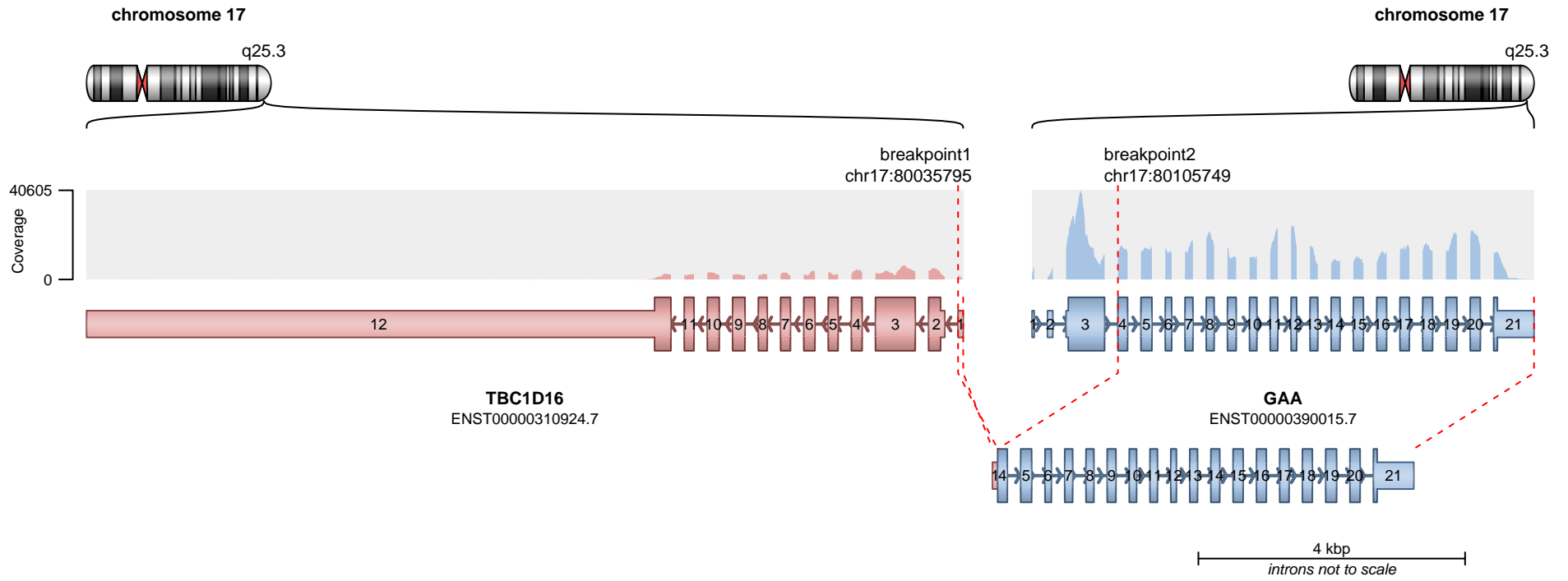

— translocation — deletion  
— duplication — inversion

**RETAINED PROTEIN DOMAINS**  
reading frame unclear

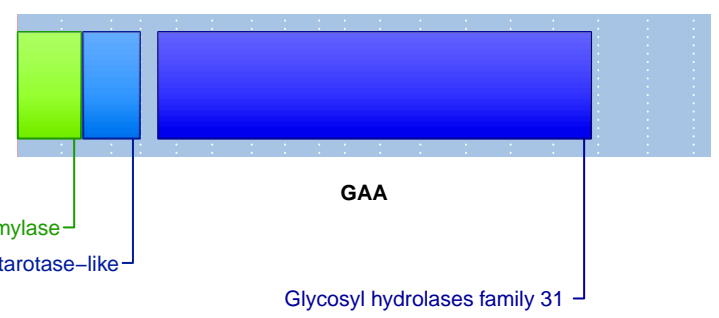

**SUPPORTING READ COUNT**

Split reads = 14  
Discordant mates = 0

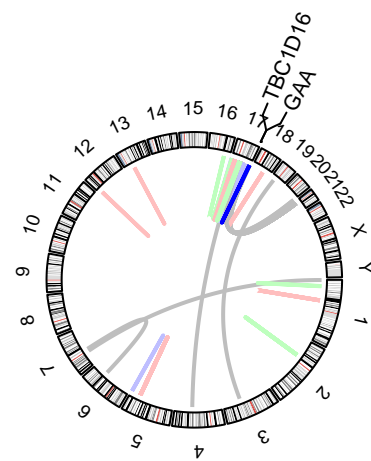
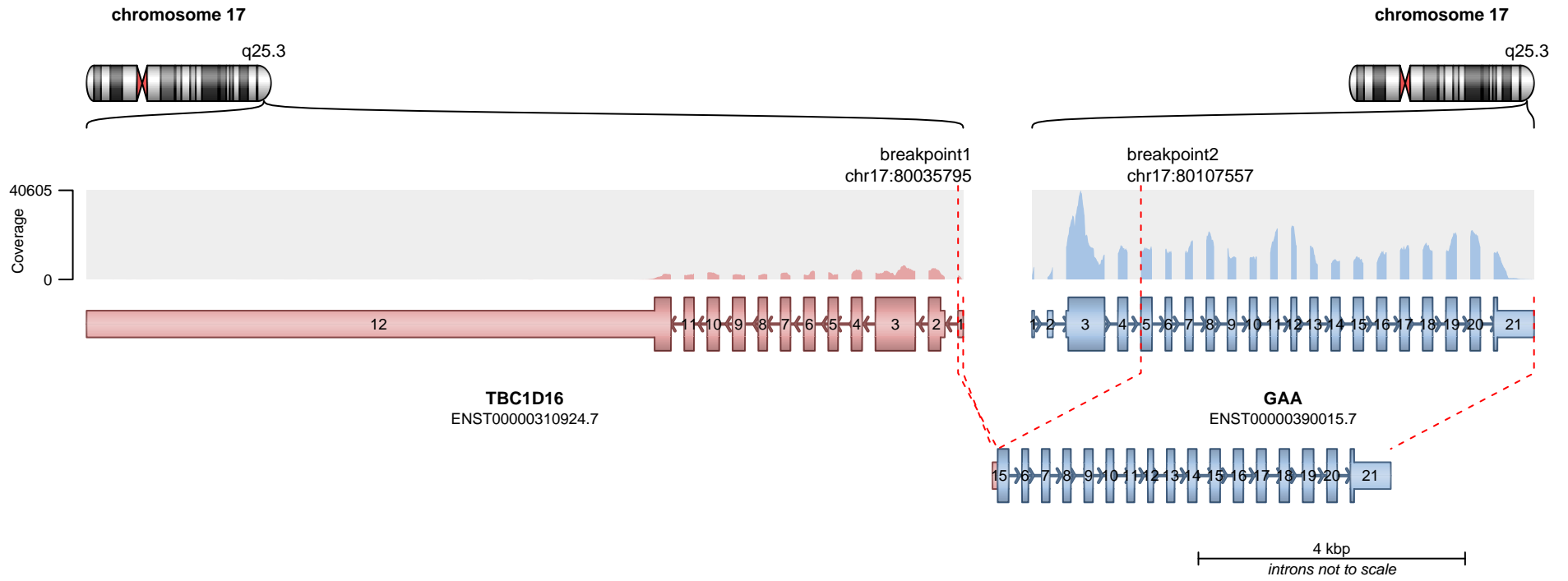

N-terminal barrel of NtMGAM and CtMGAM, maltase-glucoamylase

Galactose mutarotase-like

RETAINED PROTEIN DOMAINS  
reading frame unclear

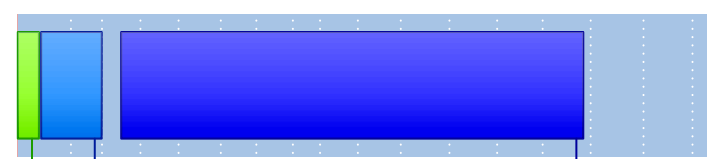

GAA

Glycosyl hydrolases family 31

SUPPORTING READ COUNT

Split reads = 4  
Discordant mates = 0

grey translocation red deletion  
green duplication blue inversion

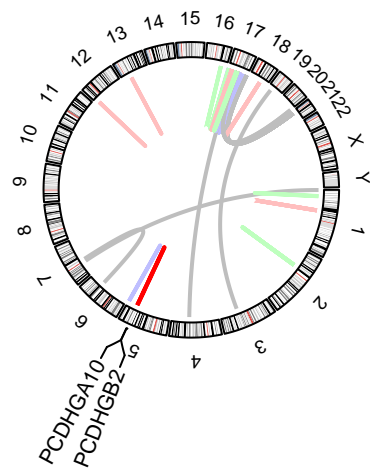
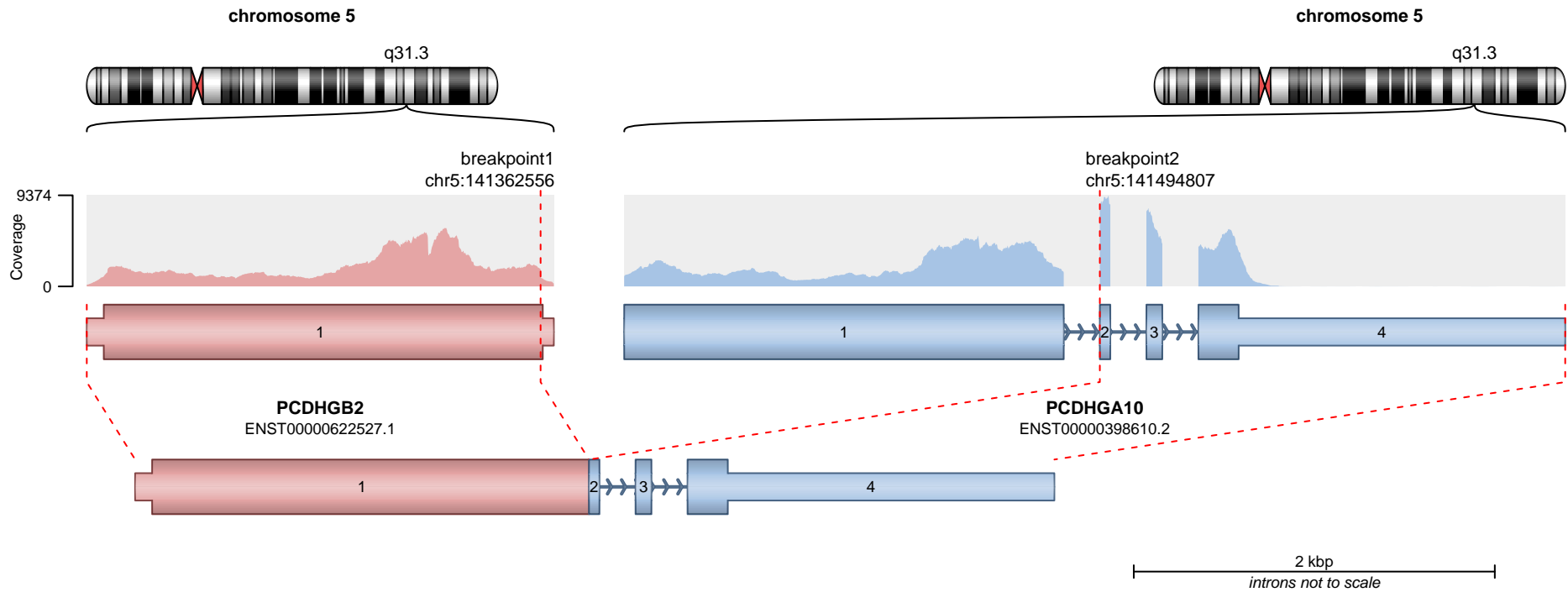

— translocation — deletion  
— duplication — inversion

**RETAINED PROTEIN DOMAINS**  
reading frame unclear

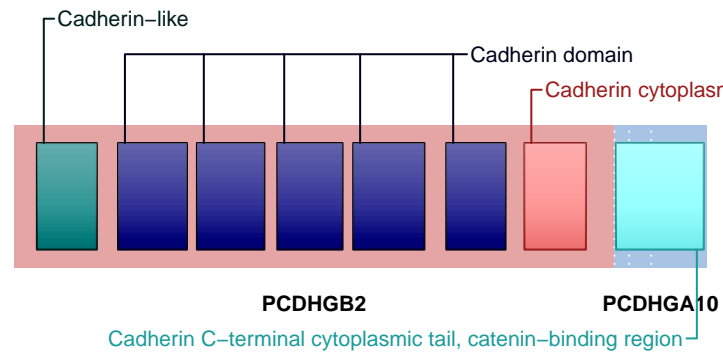

**SUPPORTING READ COUNT**

Split reads = 164  
Discordant mates = 0

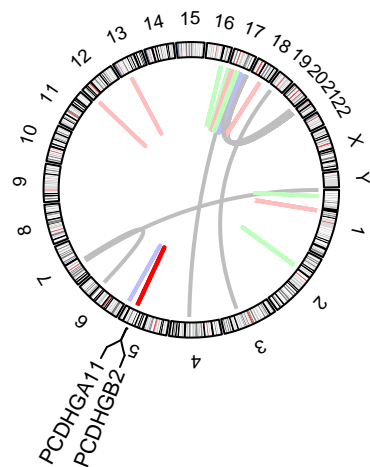
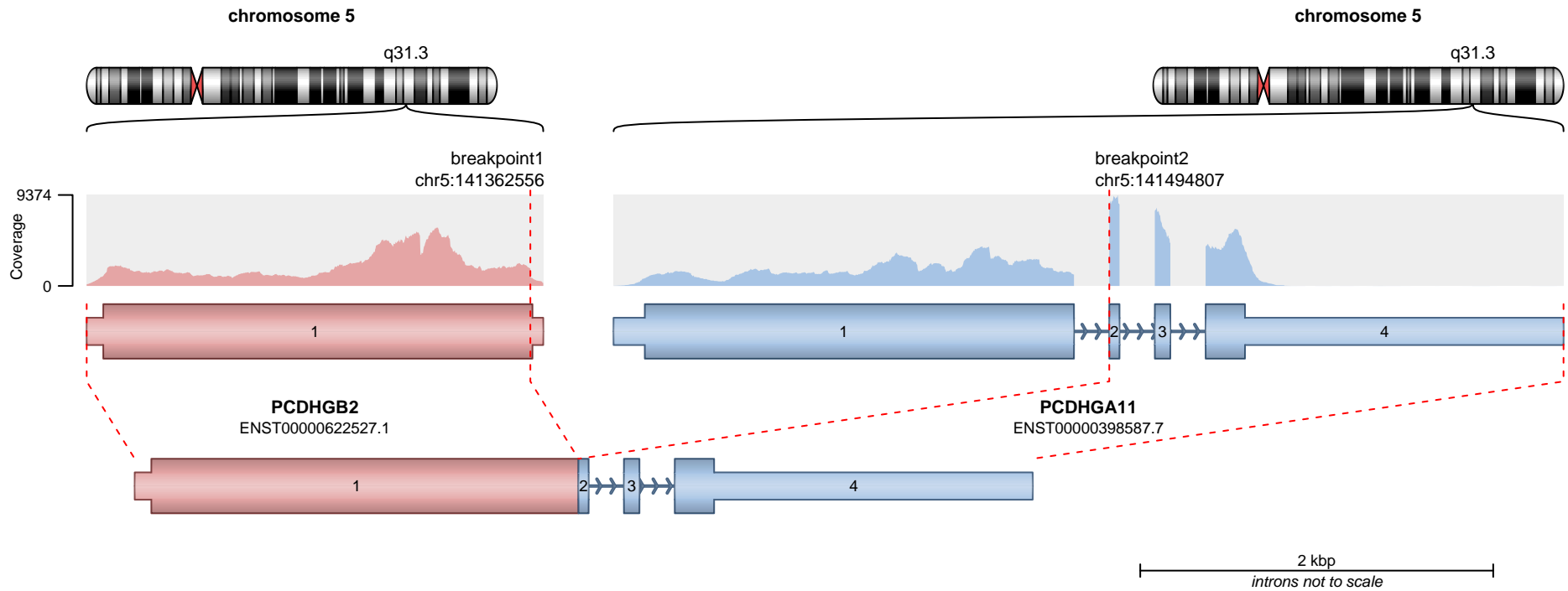

— translocation — deletion  
— duplication — inversion

**RETAINED PROTEIN DOMAINS**  
reading frame unclear

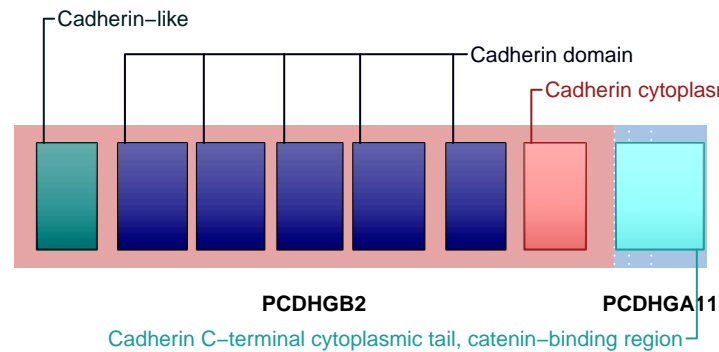

**SUPPORTING READ COUNT**

Split reads = 164  
Discordant mates = 0

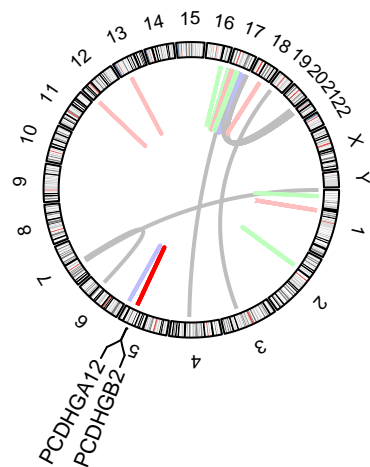
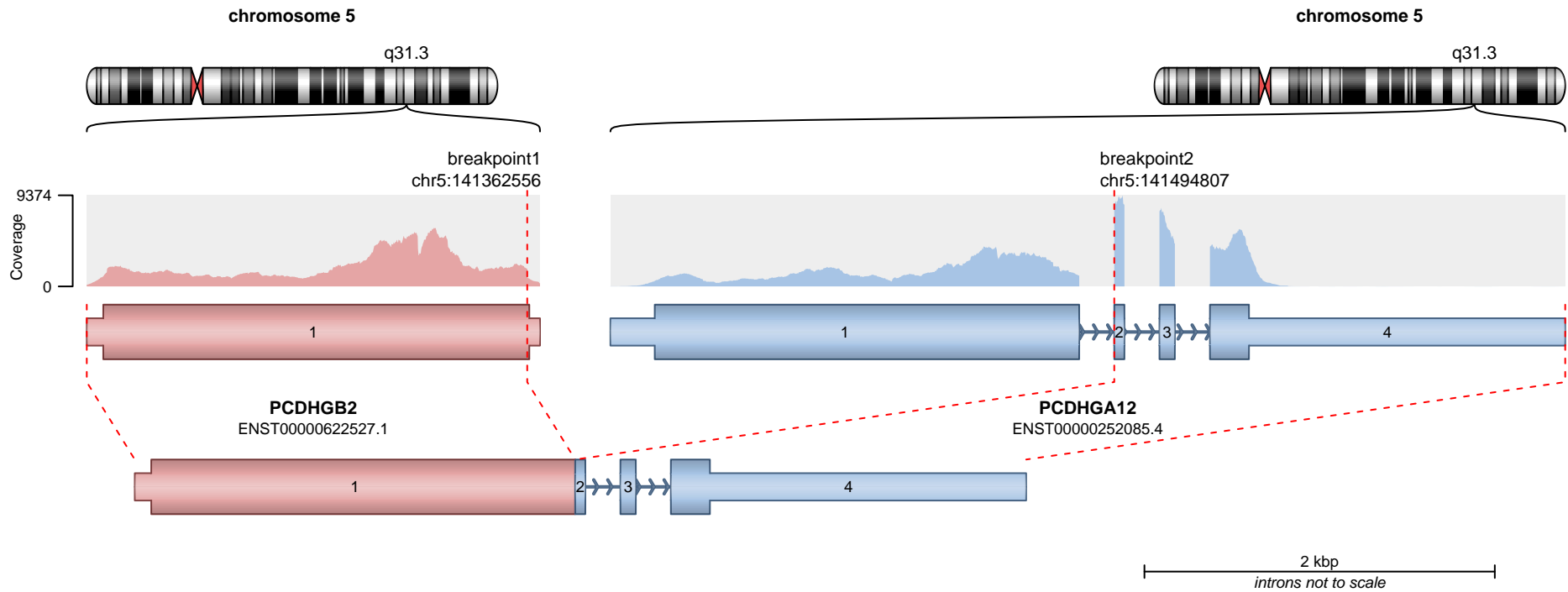

**RETAINED PROTEIN DOMAINS**  
reading frame unclear

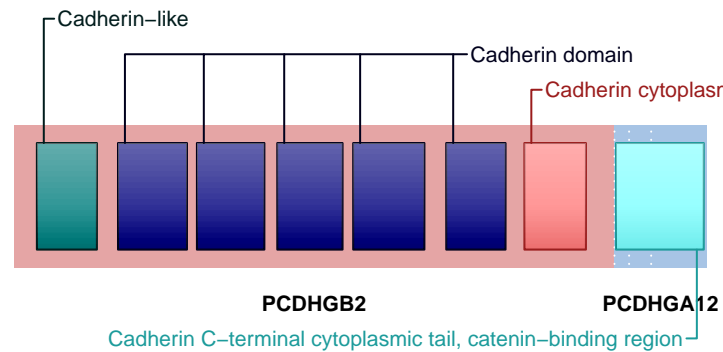

**SUPPORTING READ COUNT**

Split reads = 164  
Discordant mates = 0

— translocation    — deletion  
— duplication    — inversion

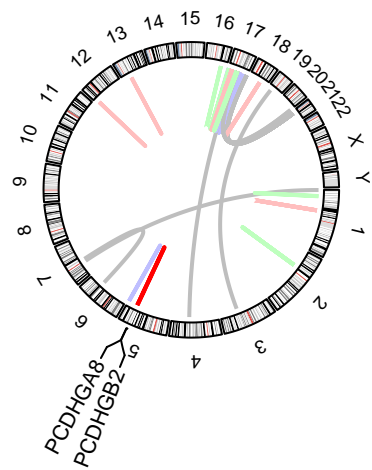
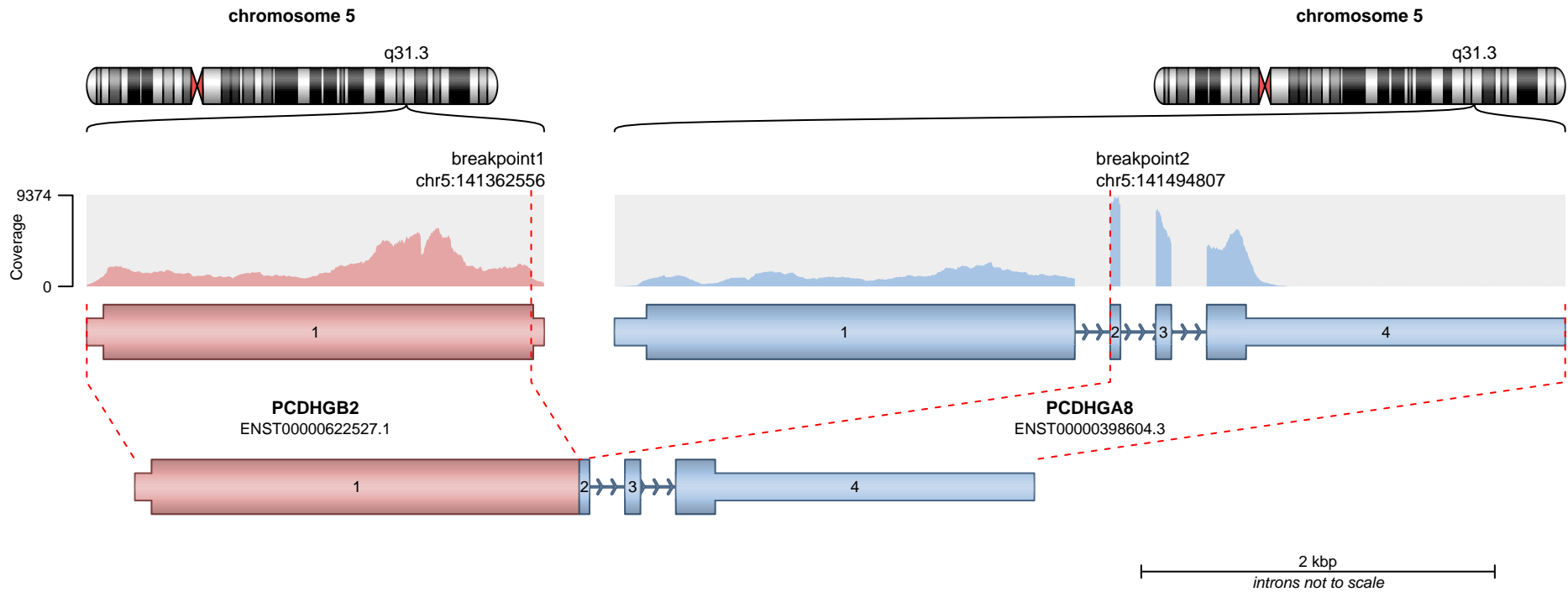

— translocation — deletion  
— duplication — inversion

**RETAINED PROTEIN DOMAINS**  
reading frame unclear

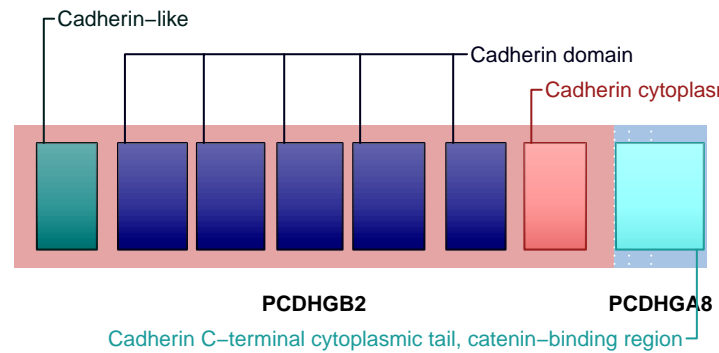

**SUPPORTING READ COUNT**

Split reads = 164  
Discordant mates = 0

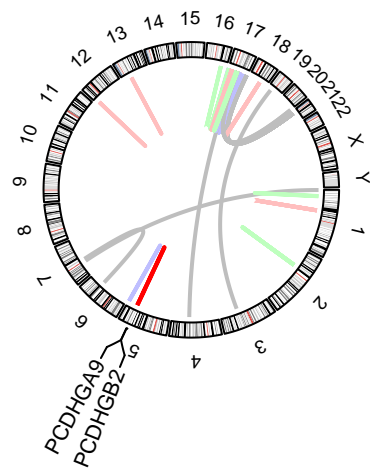
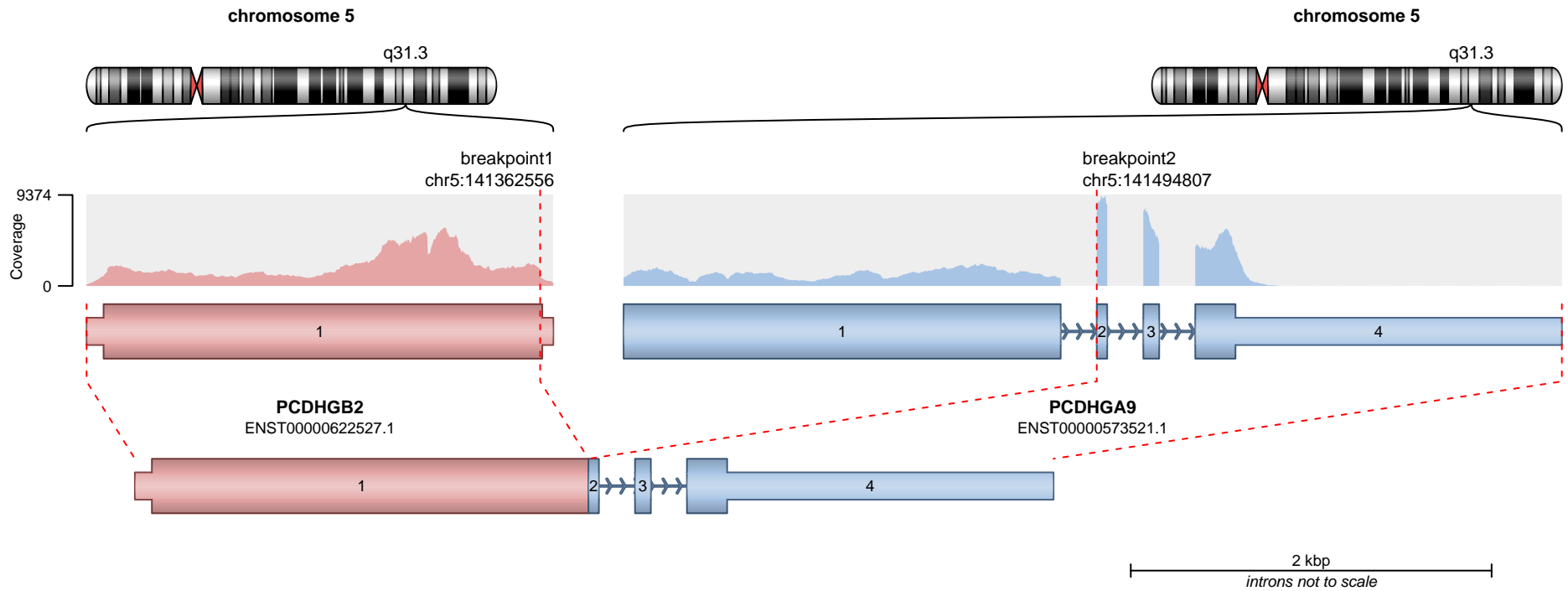

— translocation — deletion  
— duplication — inversion

**RETAINED PROTEIN DOMAINS**  
reading frame unclear

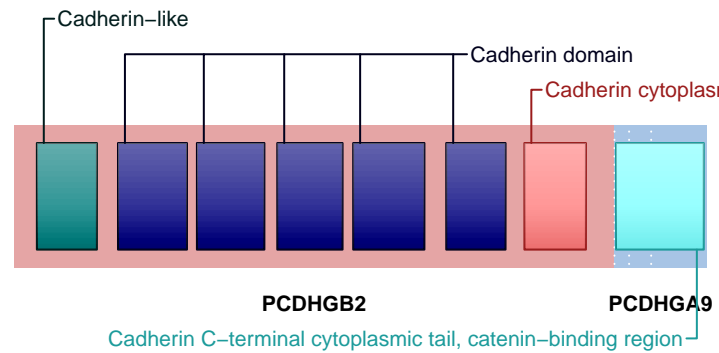

**SUPPORTING READ COUNT**

Split reads = 164  
Discordant mates = 0

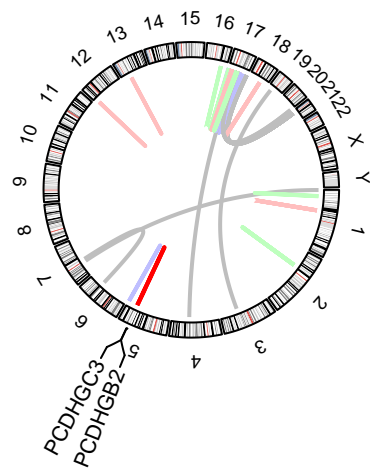
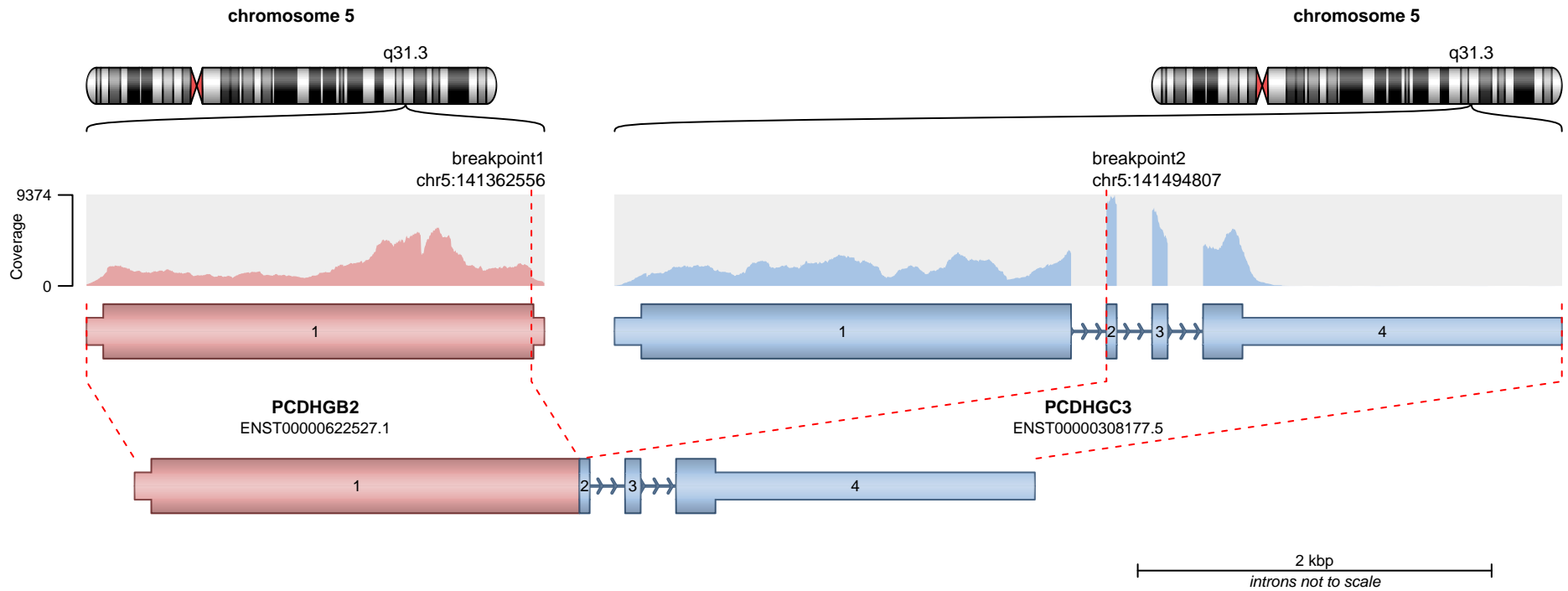

— translocation — deletion  
— duplication — inversion

**RETAINED PROTEIN DOMAINS**  
reading frame unclear

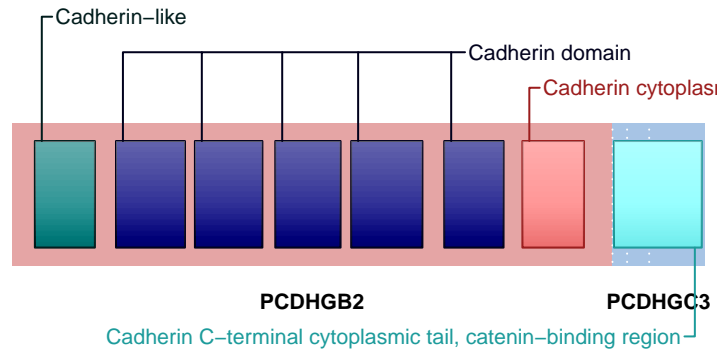

**SUPPORTING READ COUNT**

Split reads = 164  
Discordant mates = 0

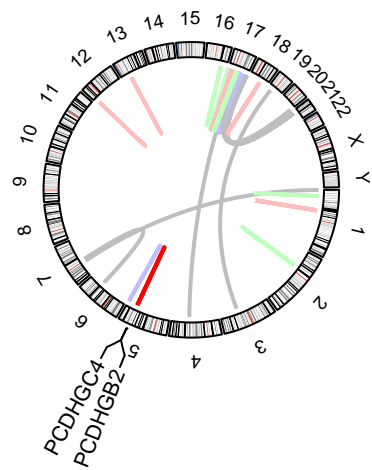
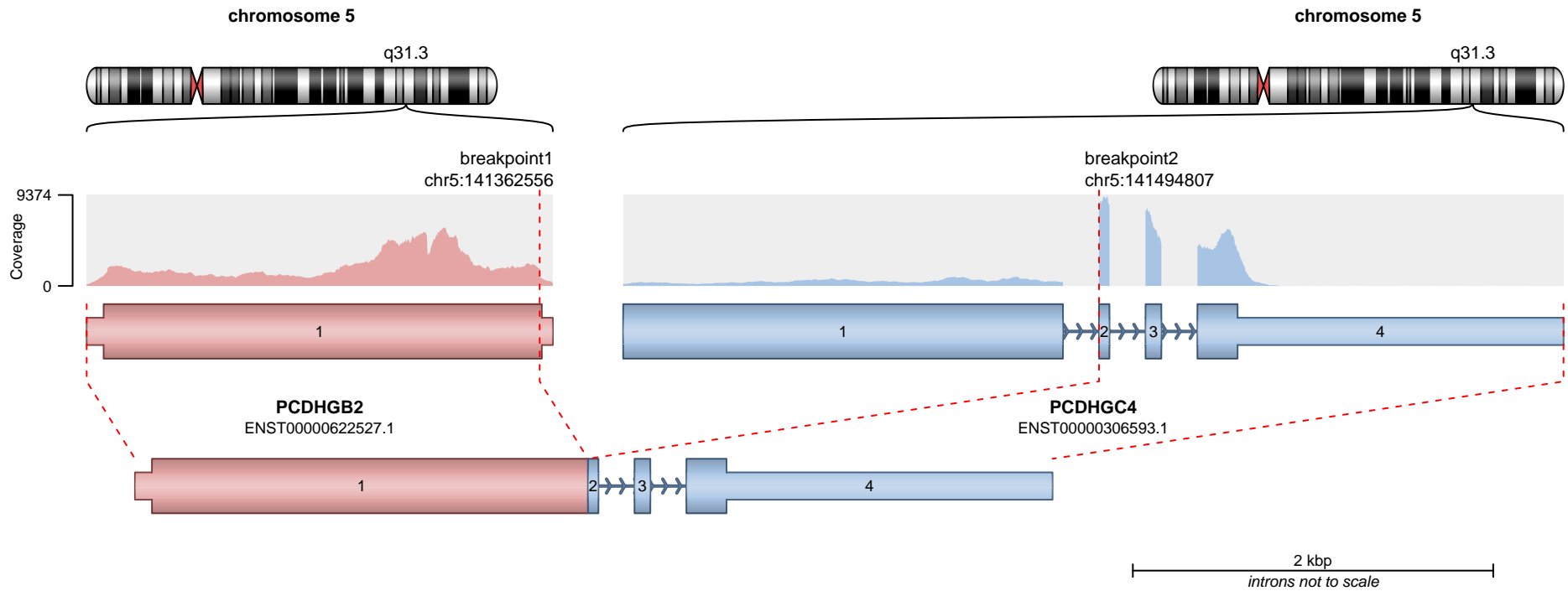

— translocation — deletion  
— duplication — inversion

**RETAINED PROTEIN DOMAINS**  
reading frame unclear

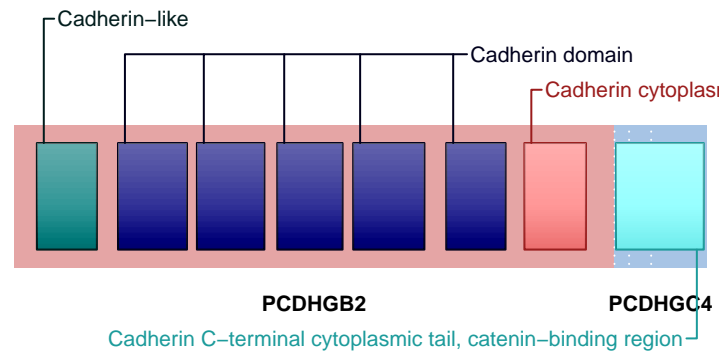

**SUPPORTING READ COUNT**

Split reads = 164  
Discordant mates = 0

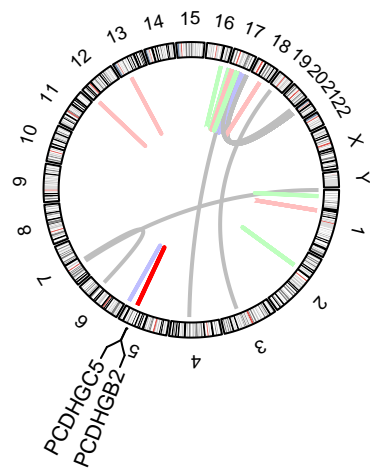
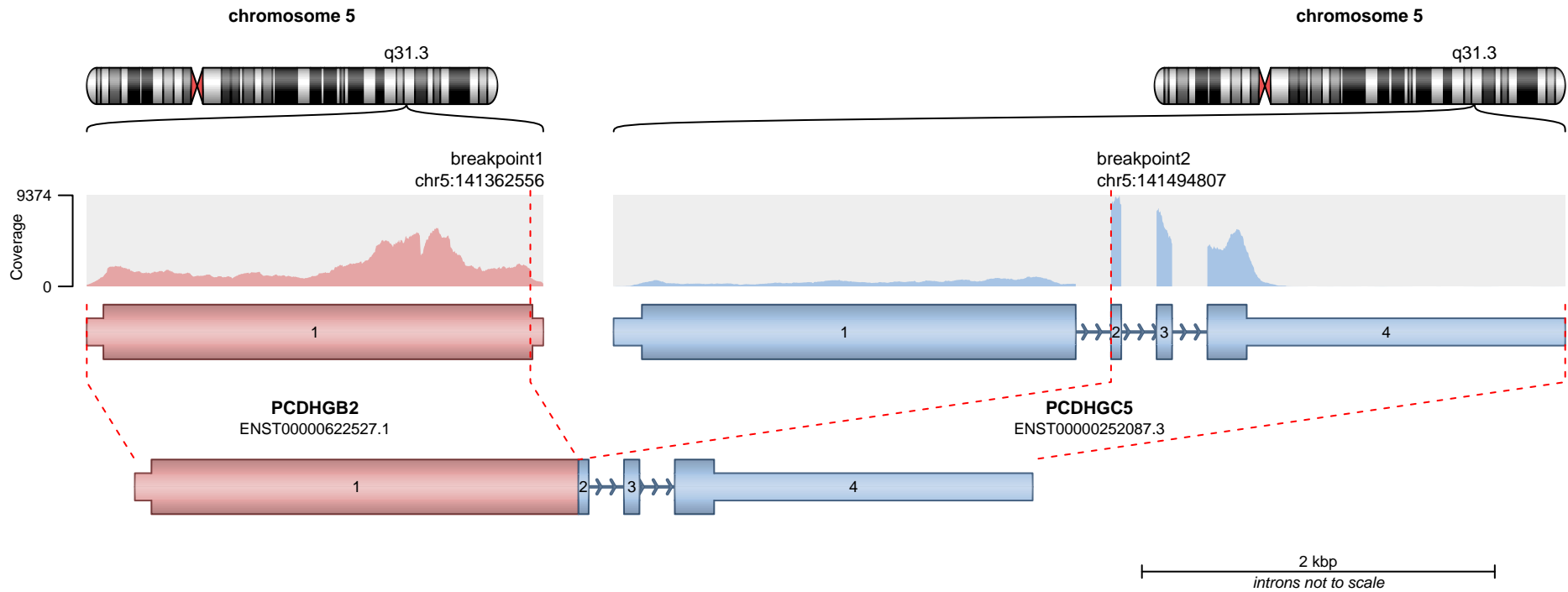

— translocation — deletion  
— duplication — inversion

### RETAINED PROTEIN DOMAINS

reading frame unclear

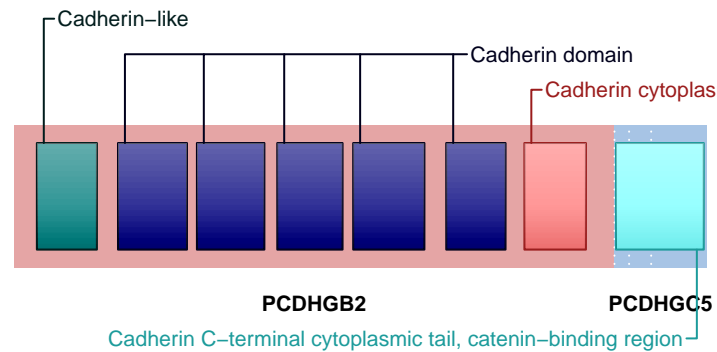

### SUPPORTING READ COUNT

Split reads = 164  
Discordant mates = 0

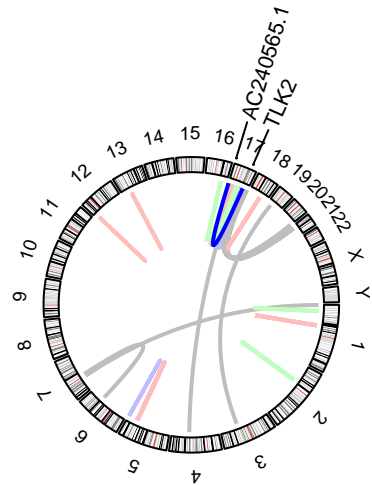
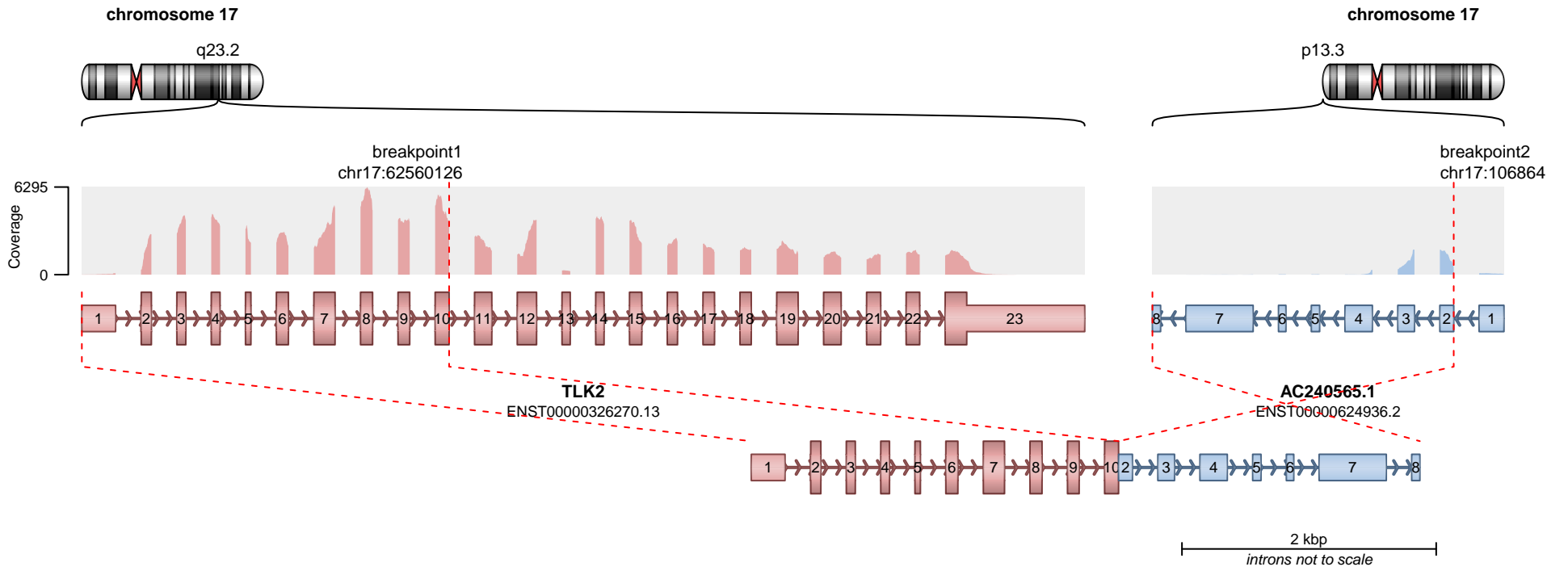

— translocation    — deletion  
— duplication      — inversion

No protein domains retained in fusion.

**SUPPORTING READ COUNT**

Split reads = 144  
Discordant mates = 3

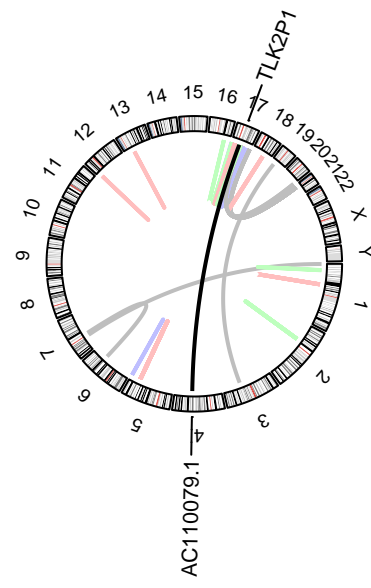
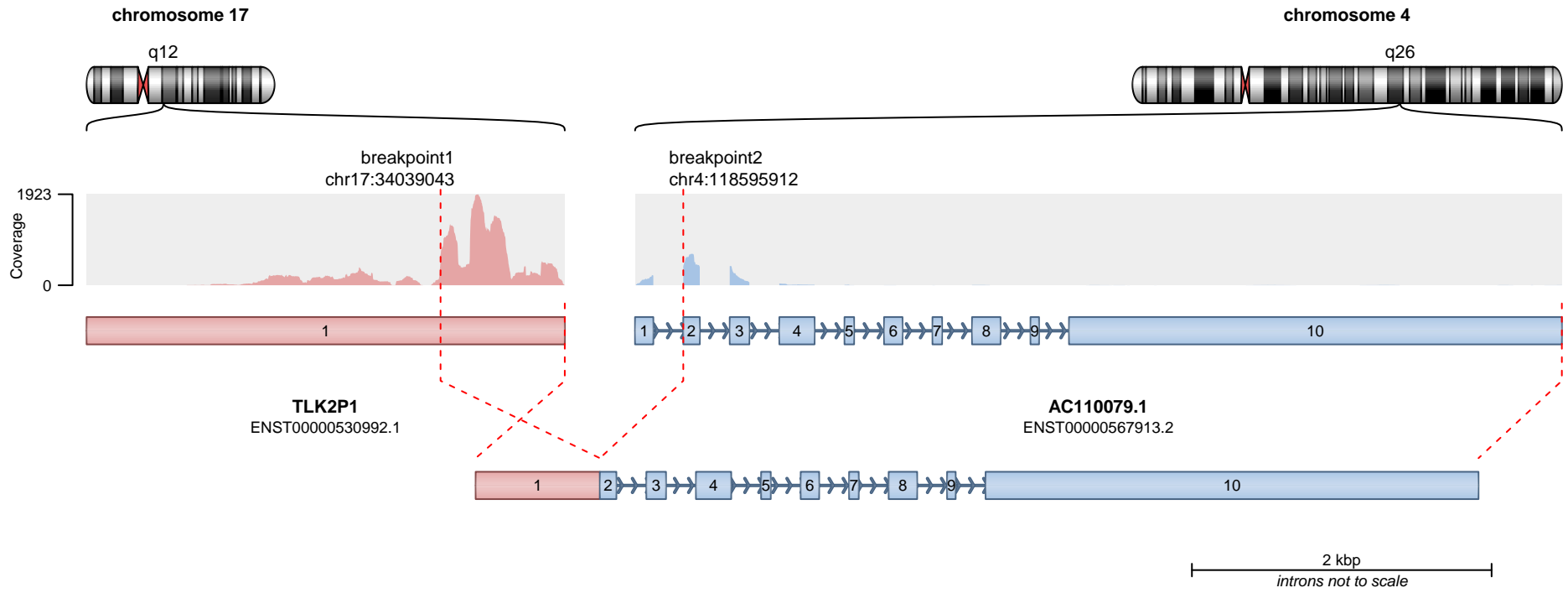

— translocation    — deletion  
 — duplication    — inversion

Genes are not protein-coding.

**SUPPORTING READ COUNT**

Split reads = 103  
 Discordant mates = 0

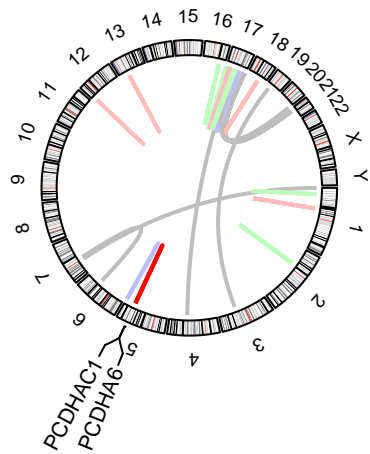
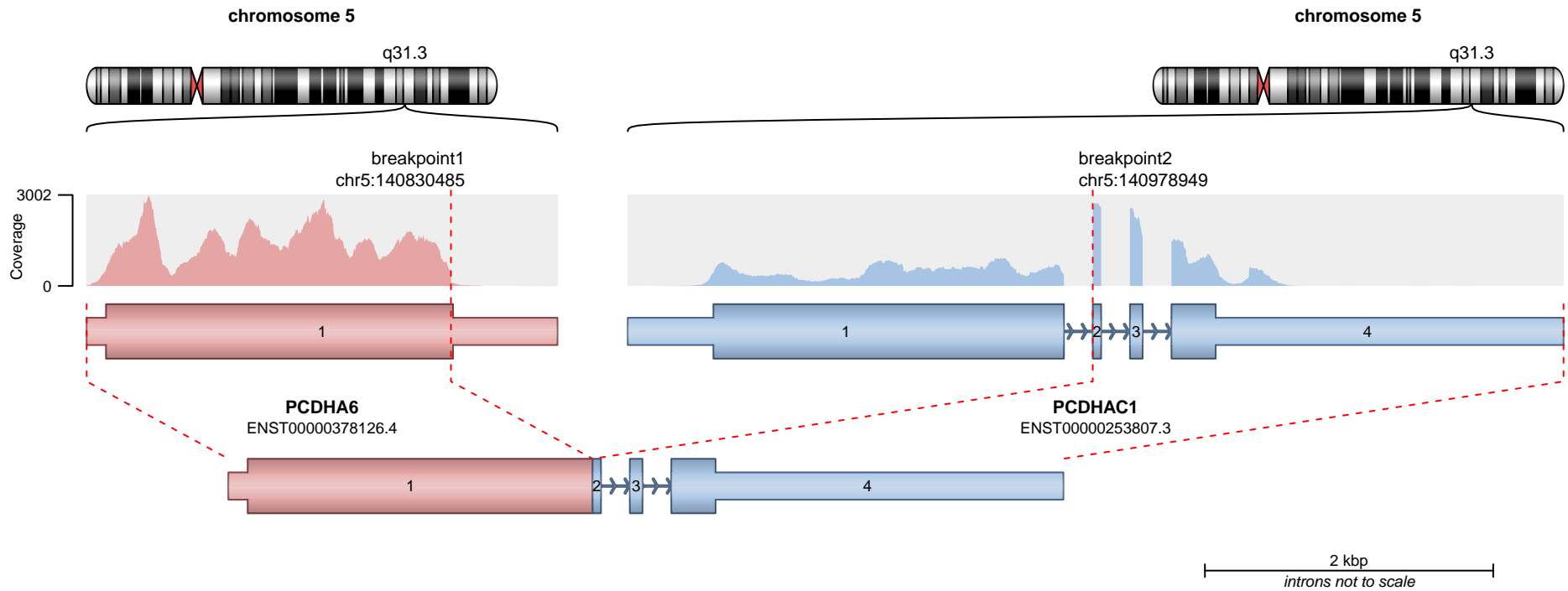

**RETAINED PROTEIN DOMAINS**  
reading frame unclear

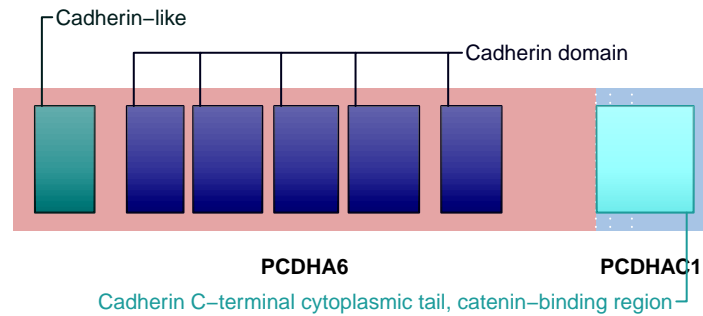

**SUPPORTING READ COUNT**

Split reads = 80  
Discordant mates = 0

— translocation    — deletion  
— duplication    — inversion

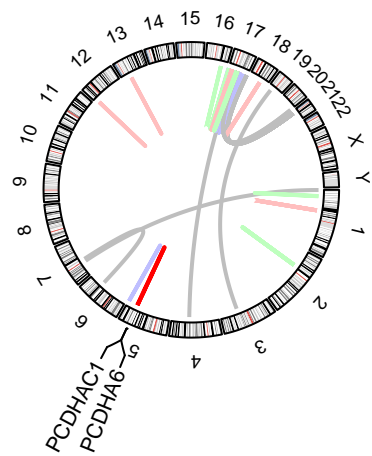
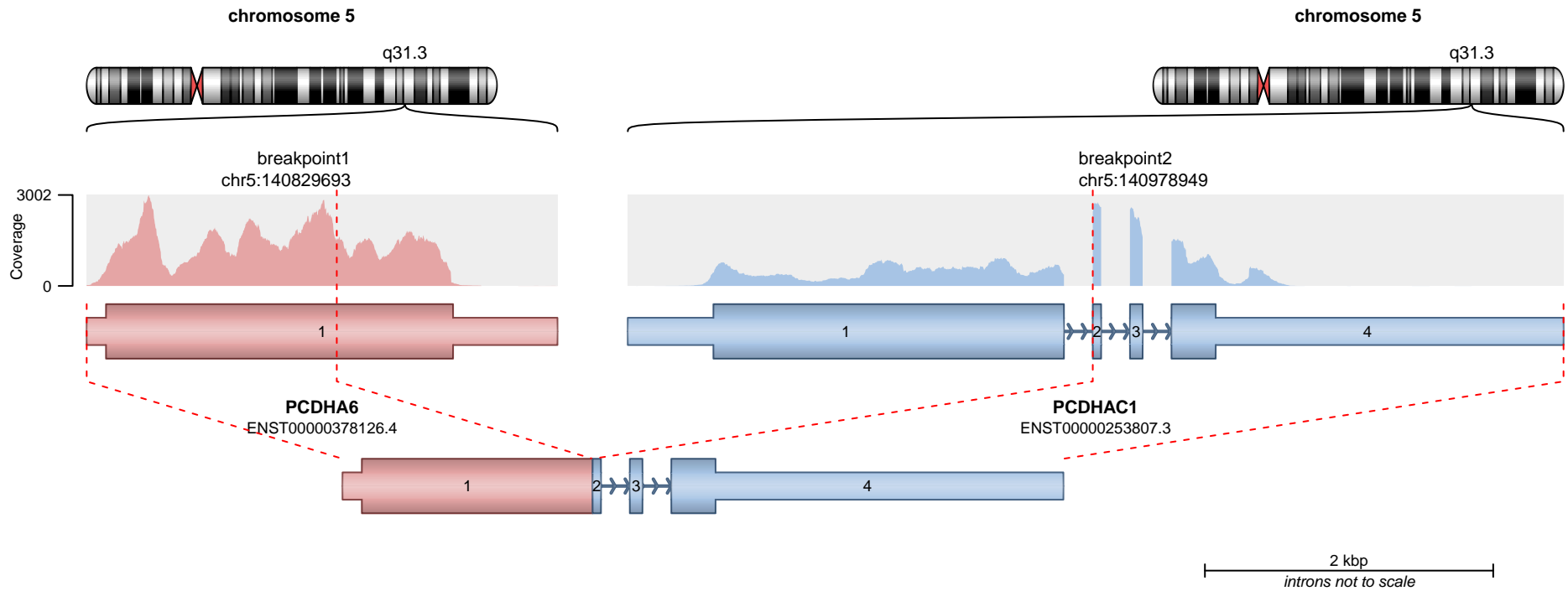

**RETAINED PROTEIN DOMAINS**  
reading frame unclear

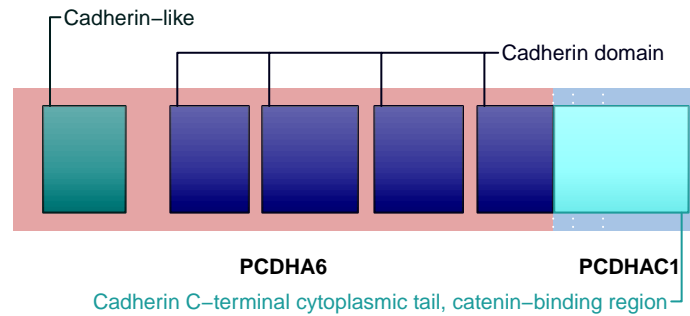

**SUPPORTING READ COUNT**

Split reads = 12  
Discordant mates = 0

— translocation    — deletion  
— duplication    — inversion

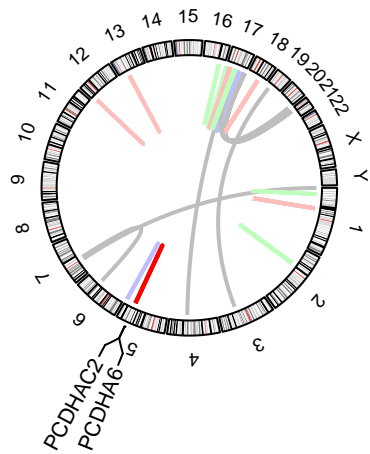
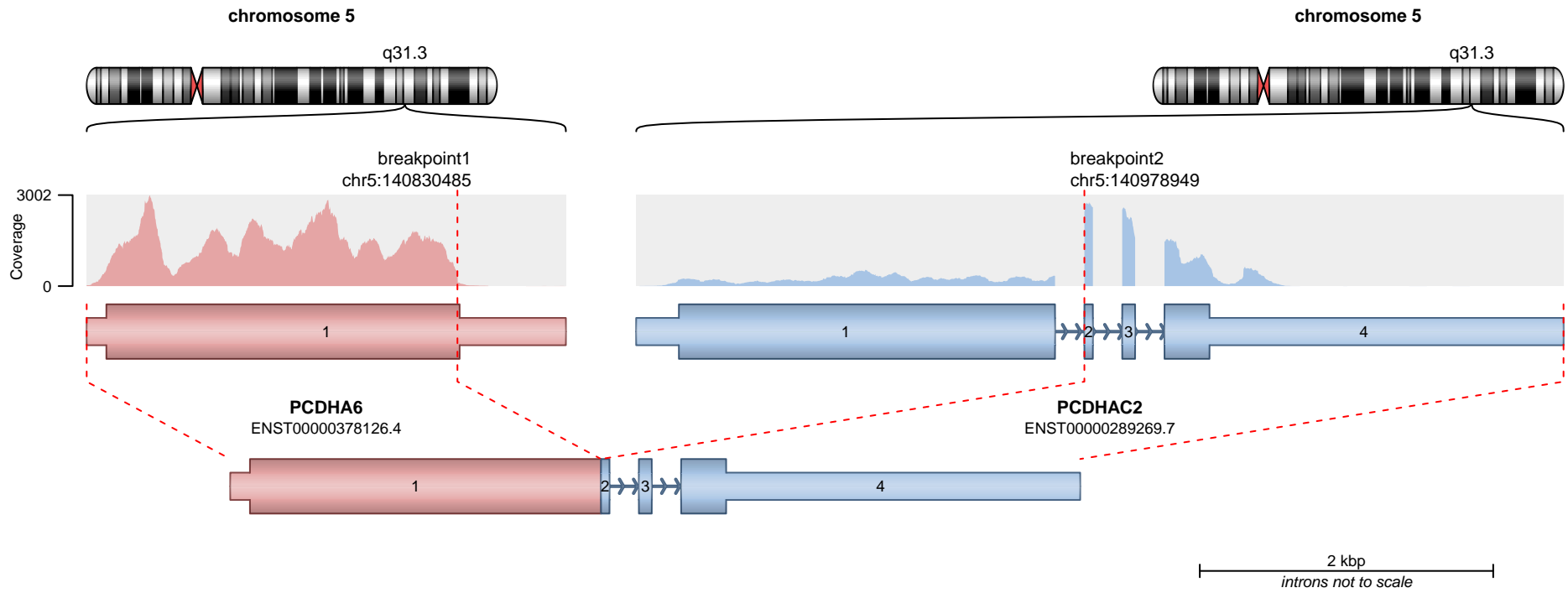

**RETAINED PROTEIN DOMAINS**  
reading frame unclear

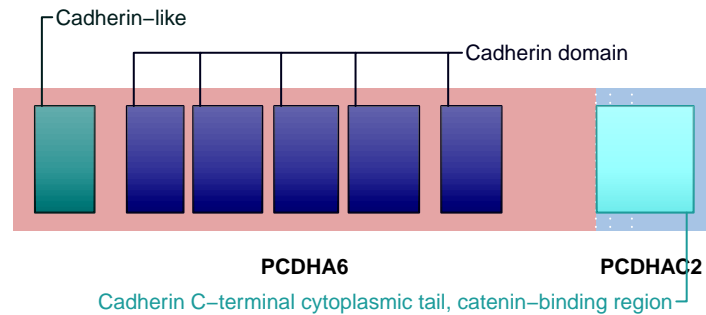

**SUPPORTING READ COUNT**

Split reads = 80  
Discordant mates = 0

— translocation    — deletion  
— duplication    — inversion

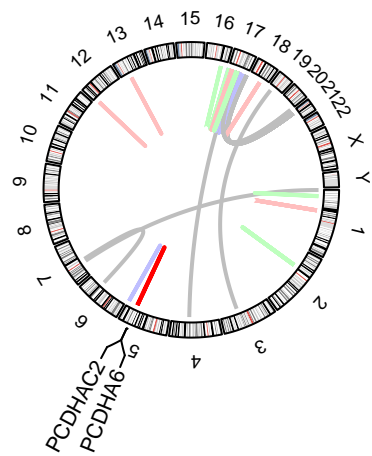
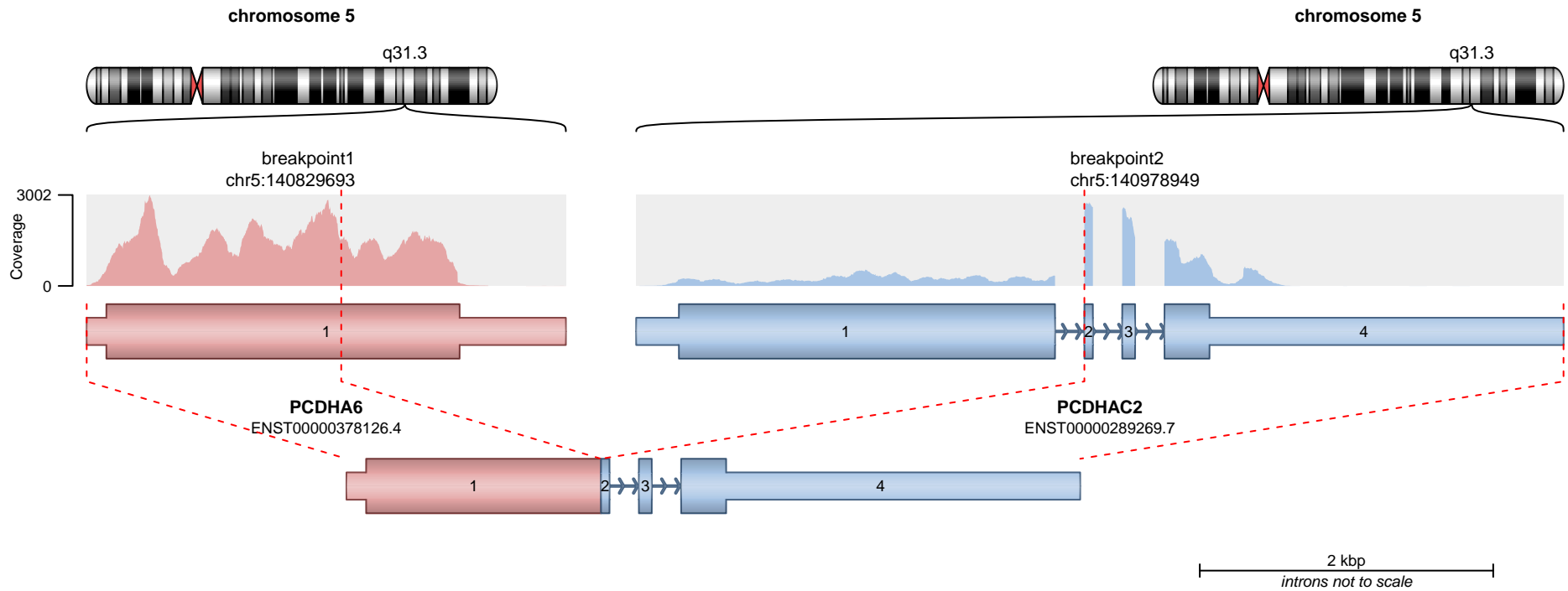

**RETAINED PROTEIN DOMAINS**  
reading frame unclear

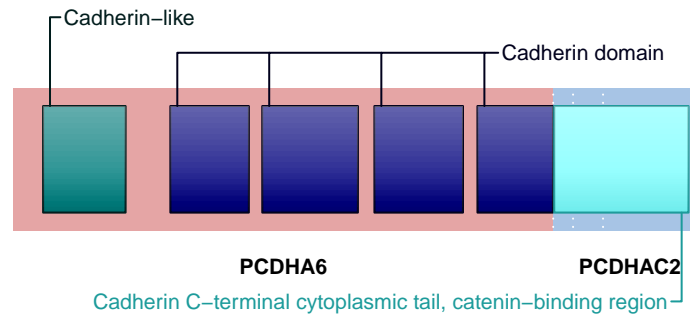

**SUPPORTING READ COUNT**

Split reads = 12  
Discordant mates = 0

— translocation    — deletion  
— duplication    — inversion

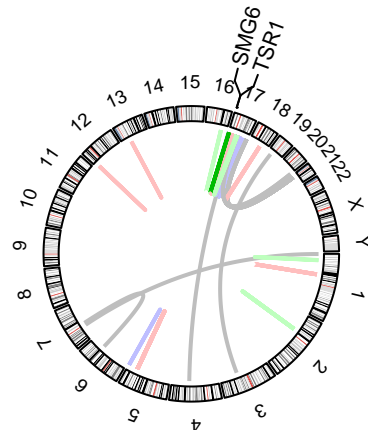
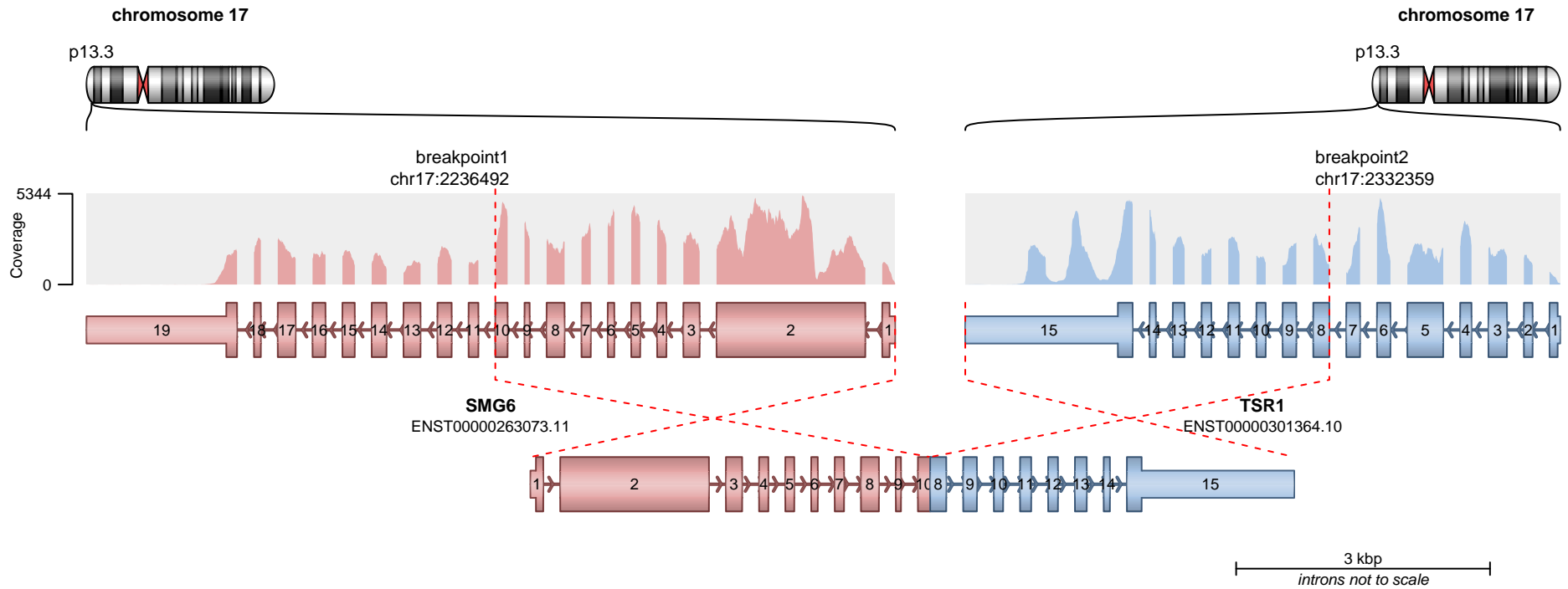

**RETAINED PROTEIN DOMAINS**  
reading frame unclear

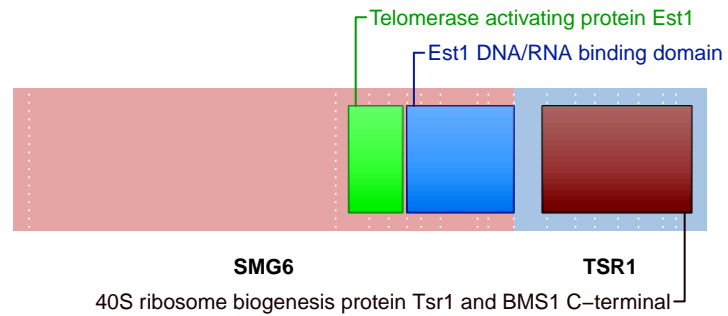

**SUPPORTING READ COUNT**

Split reads = 79  
Discordant mates = 2

- translocation
- duplication
- deletion
- inversion

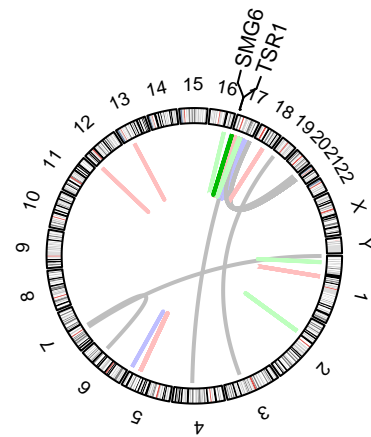
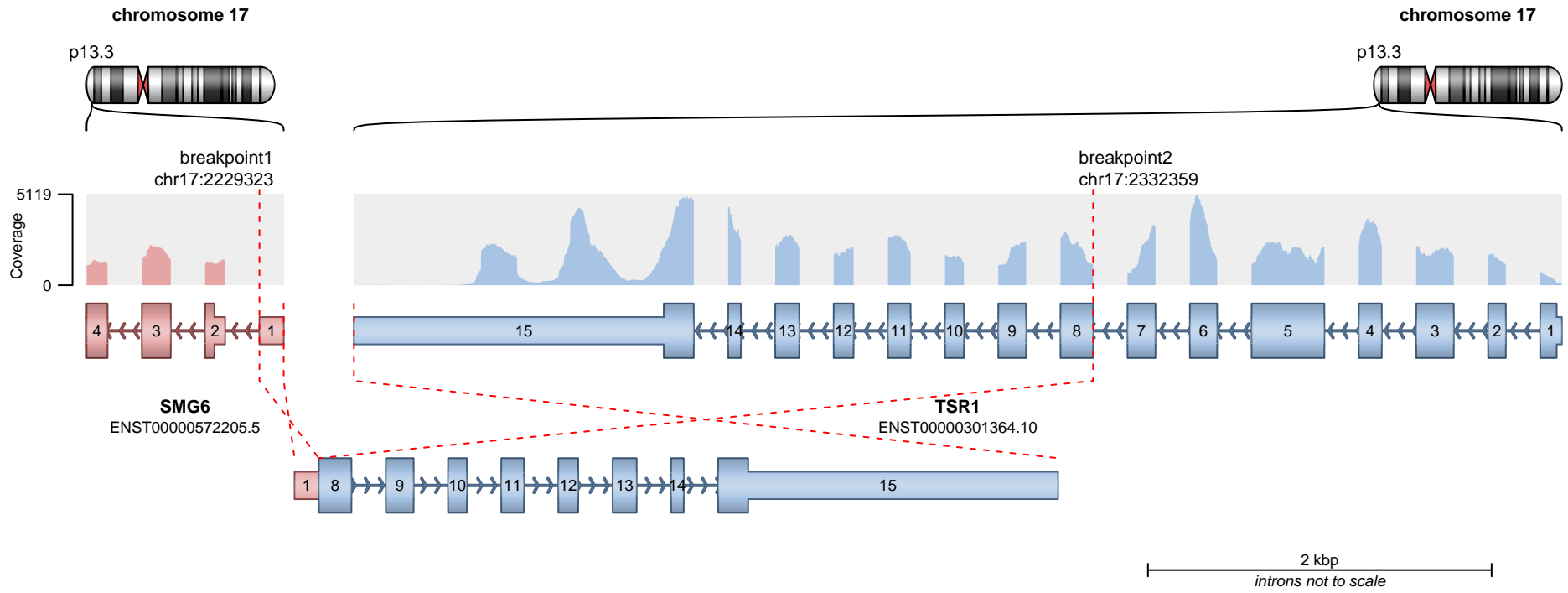

— translocation — deletion  
— duplication — inversion

**RETAINED PROTEIN DOMAINS**  
reading frame unclear

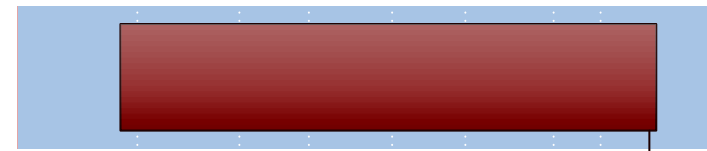

**TSR1**

40S ribosome biogenesis protein Tsr1 and BMS1 C-terminal

**SUPPORTING READ COUNT**

Split reads = 1  
Discordant mates = 2

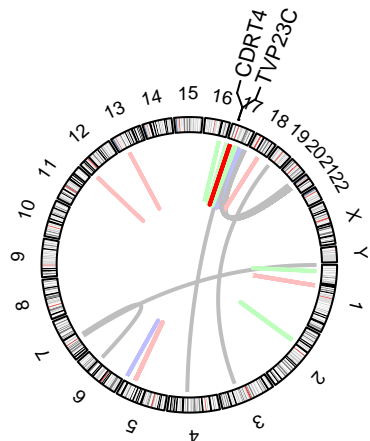
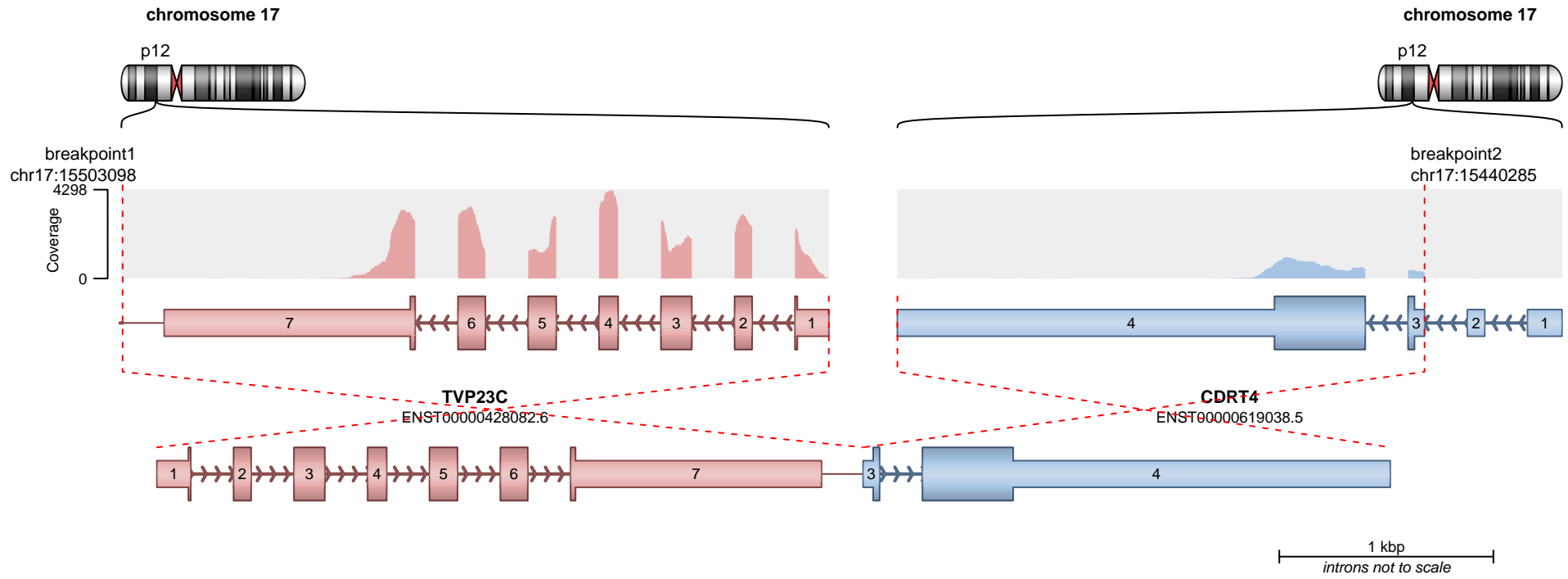

**RETAINED PROTEIN DOMAINS**  
reading frame unclear

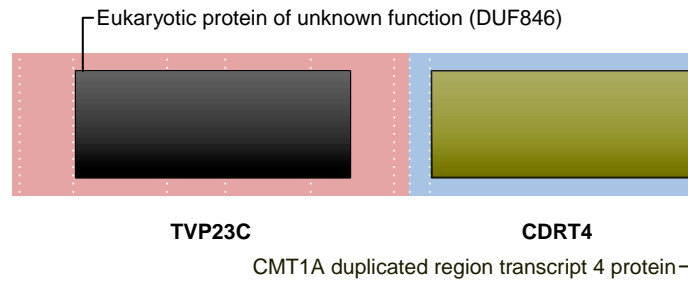

**SUPPORTING READ COUNT**

Split reads = 48  
Discordant mates = 0

— translocation — deletion  
— duplication — inversion

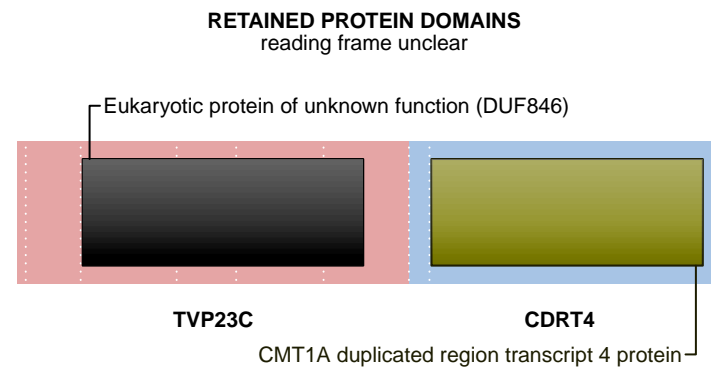
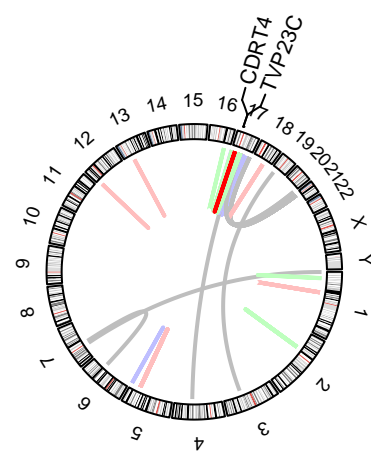
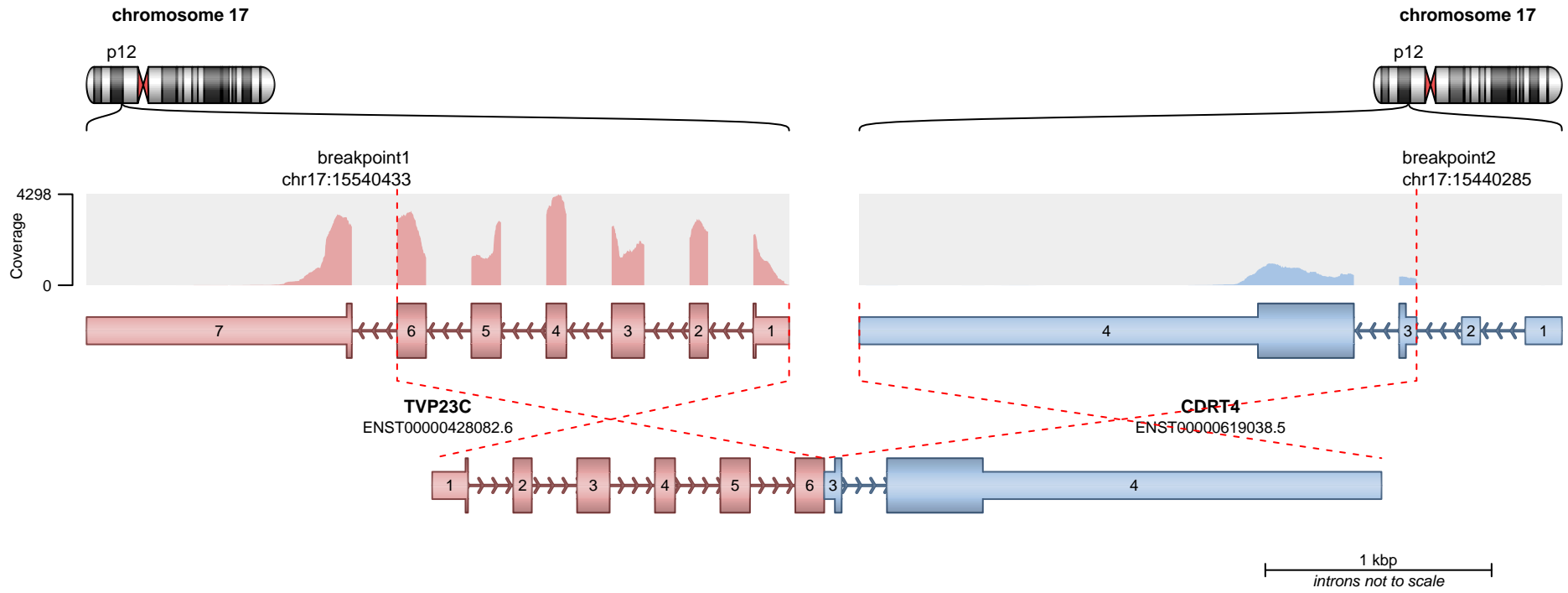

**SUPPORTING READ COUNT**

Split reads = 22  
Discordant mates = 0

— translocation — deletion  
— duplication — inversion

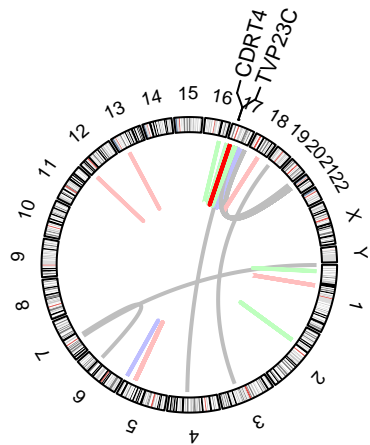
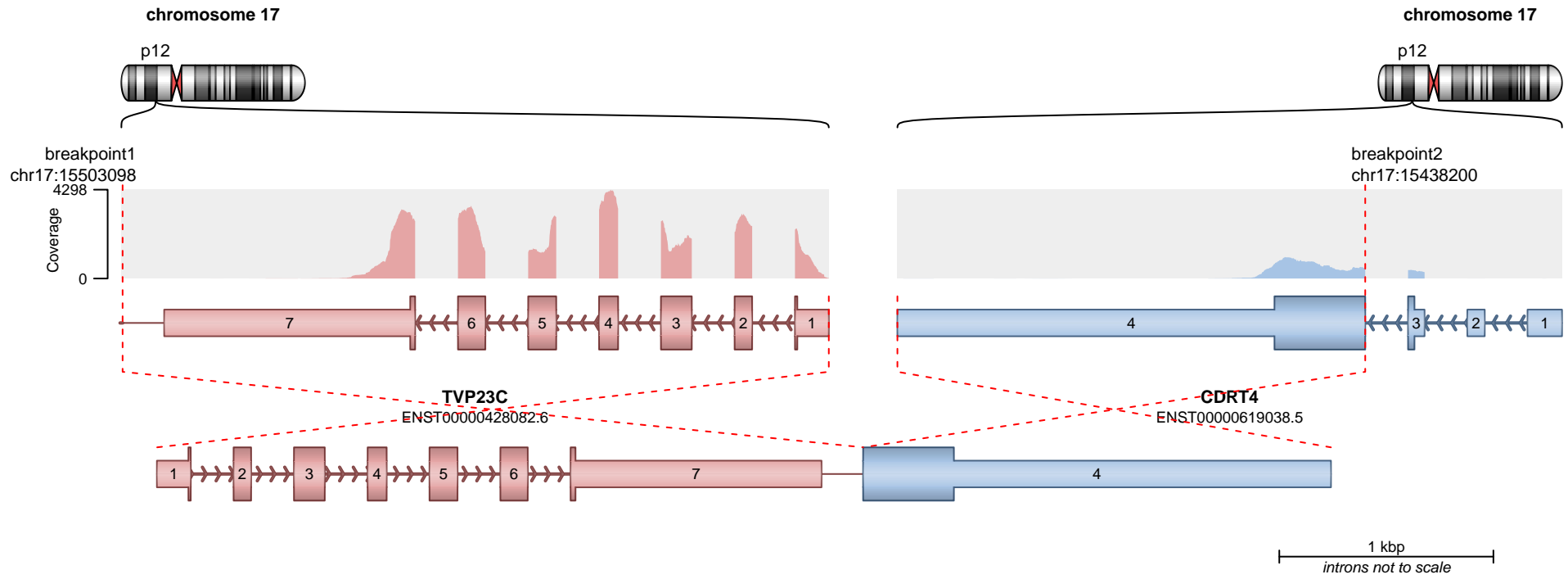

**RETAINED PROTEIN DOMAINS**  
reading frame unclear

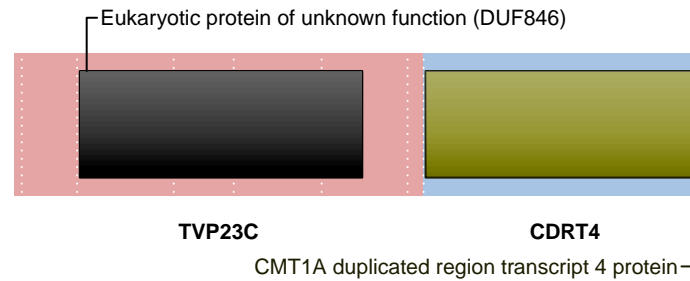

**SUPPORTING READ COUNT**

Split reads = 15  
Discordant mates = 0

— translocation — deletion  
— duplication — inversion

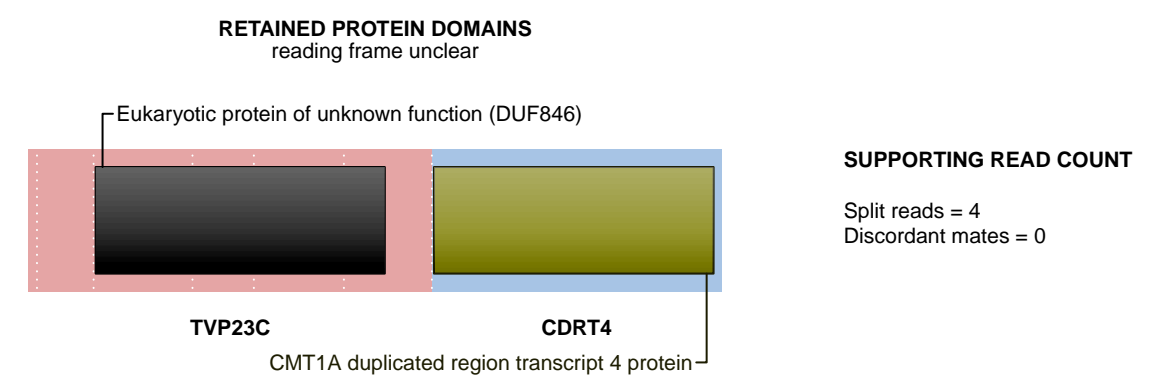
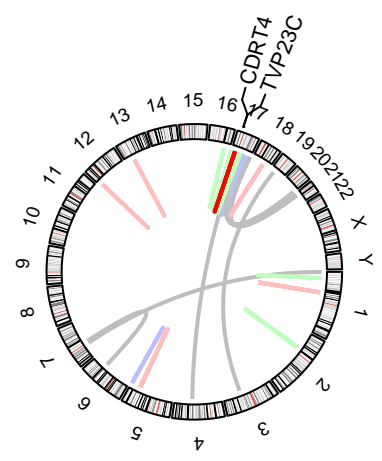
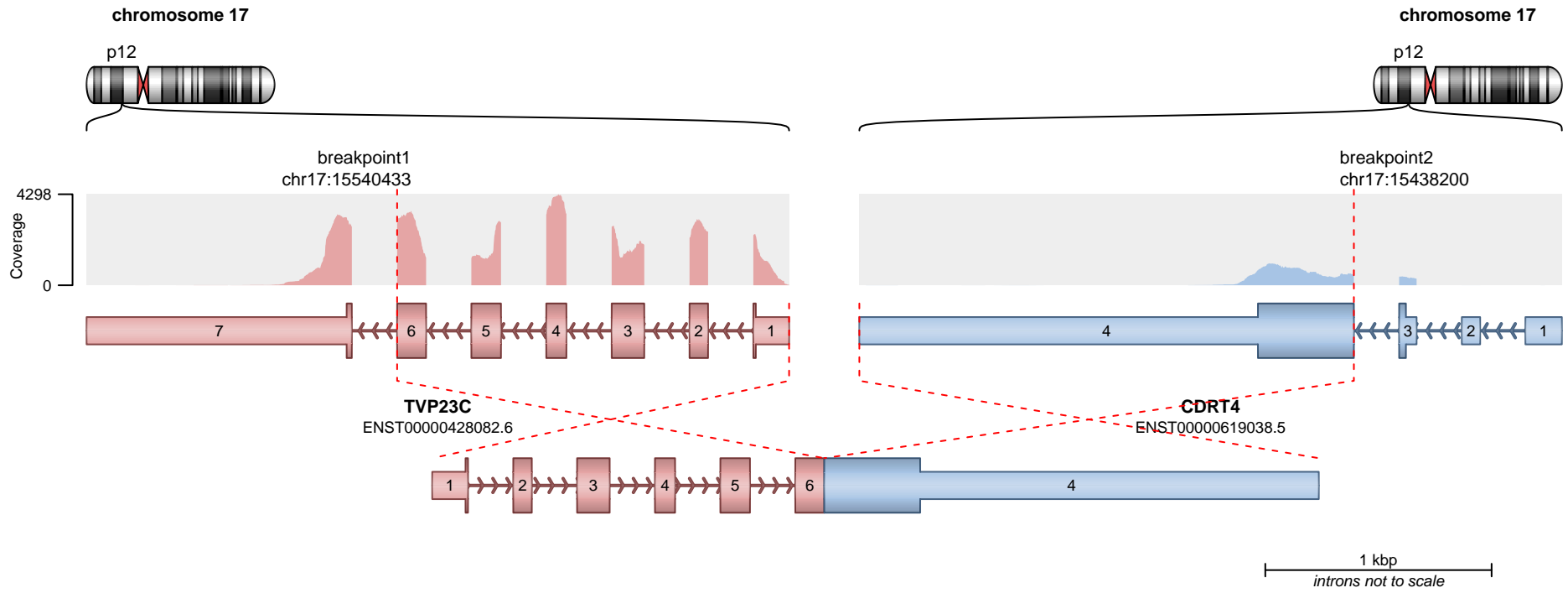

— translocation    — deletion  
— duplication    — inversion

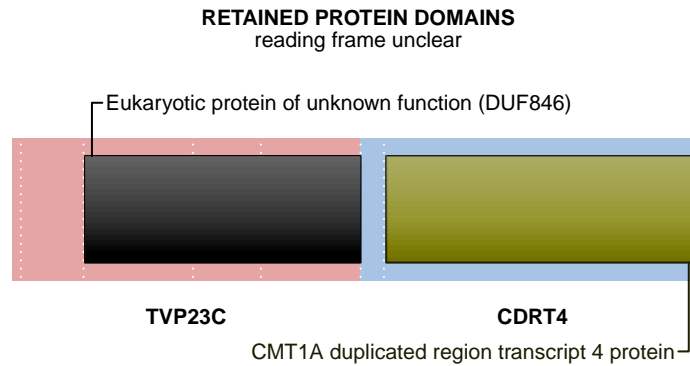
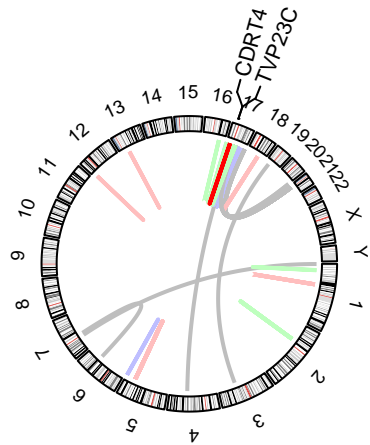
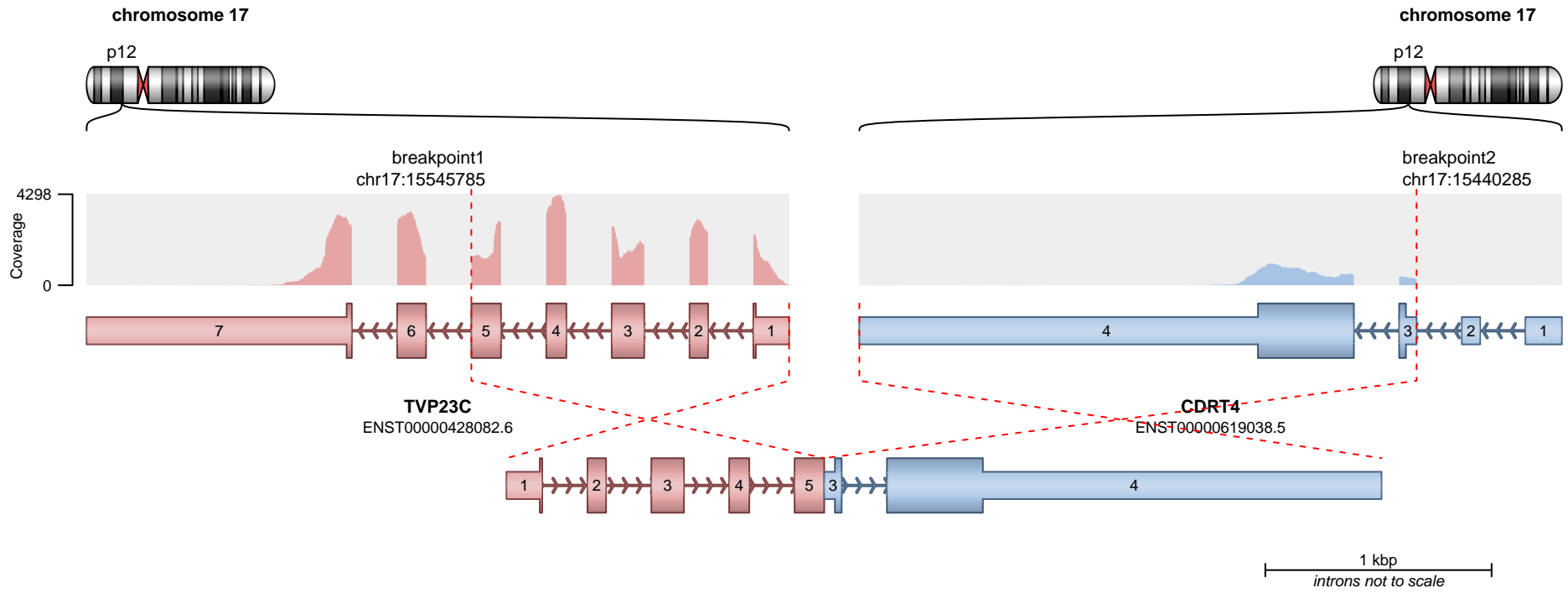

**SUPPORTING READ COUNT**

Split reads = 1  
Discordant mates = 0

— translocation — deletion  
— duplication — inversion

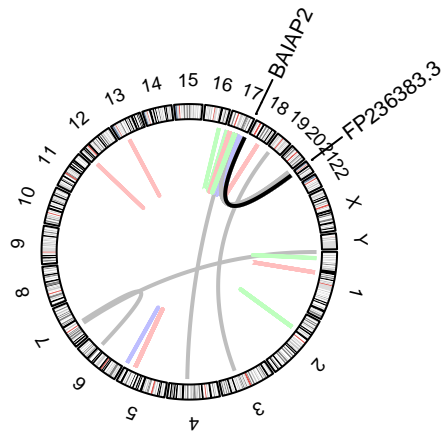
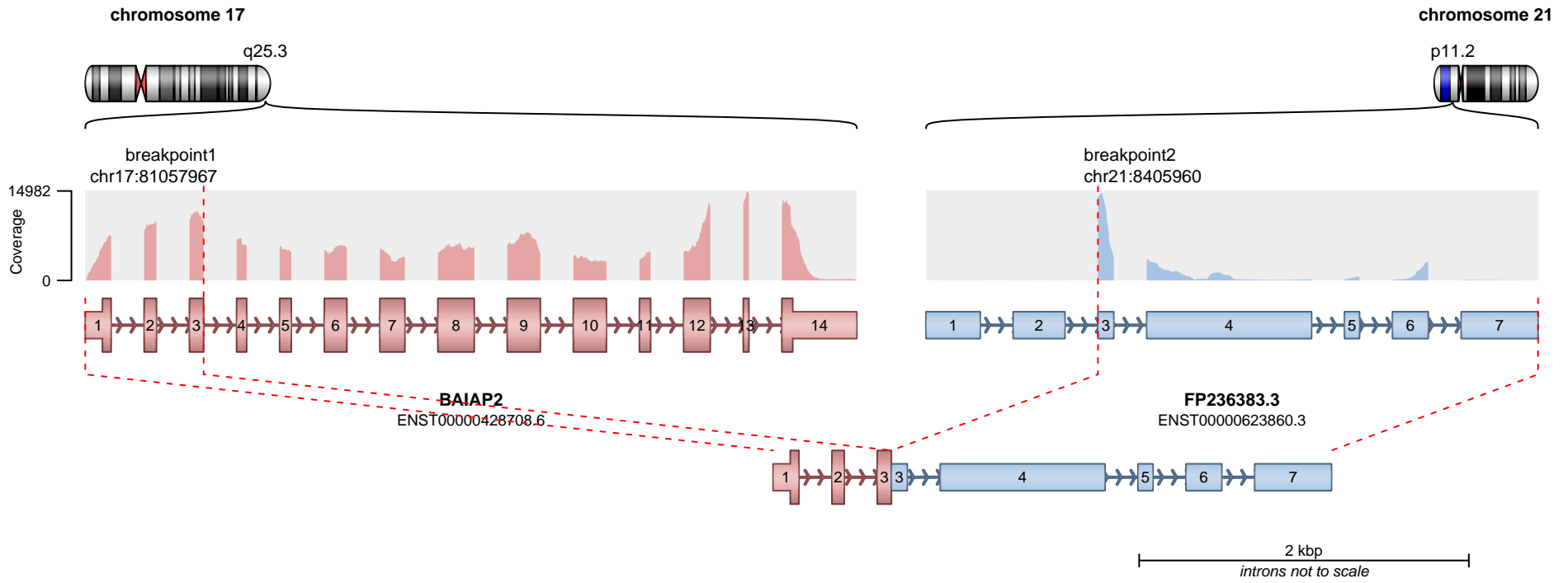

**RETAINED PROTEIN DOMAINS**  
reading frame unclear

IRSp53/MIM homology domain

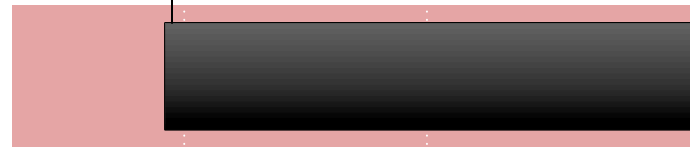

**BAIAP2**

**SUPPORTING READ COUNT**

Split reads = 43  
Discordant mates = 0

- translocation
- duplication
- deletion
- inversion

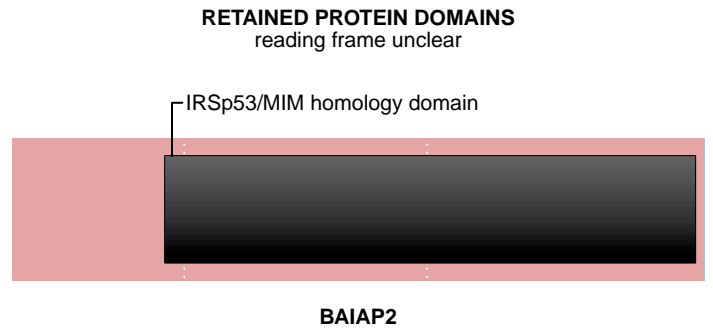
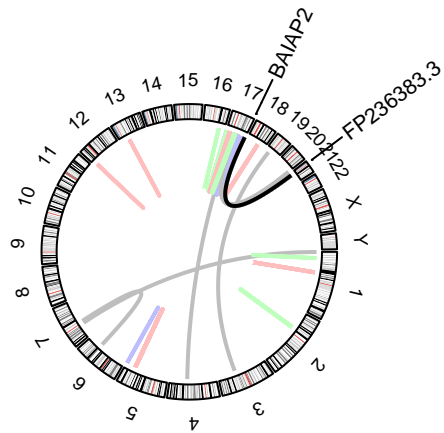
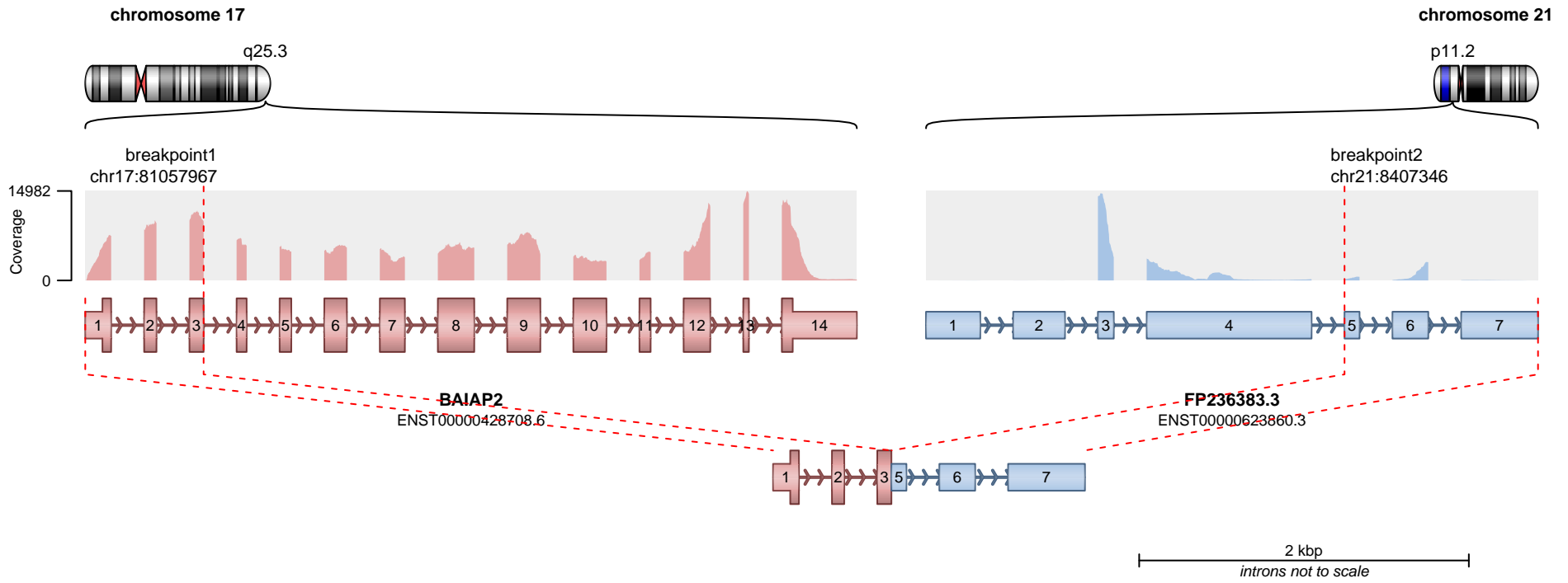

**SUPPORTING READ COUNT**  
Split reads = 12  
Discordant mates = 0

— translocation    — deletion  
— duplication    — inversion

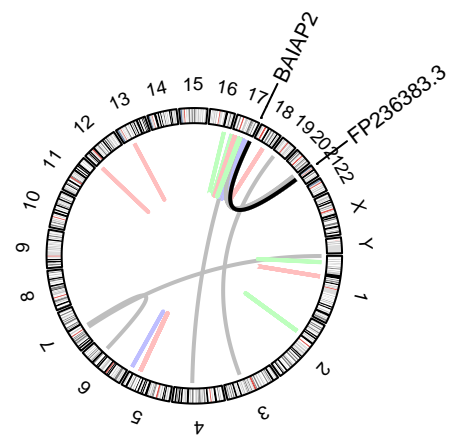
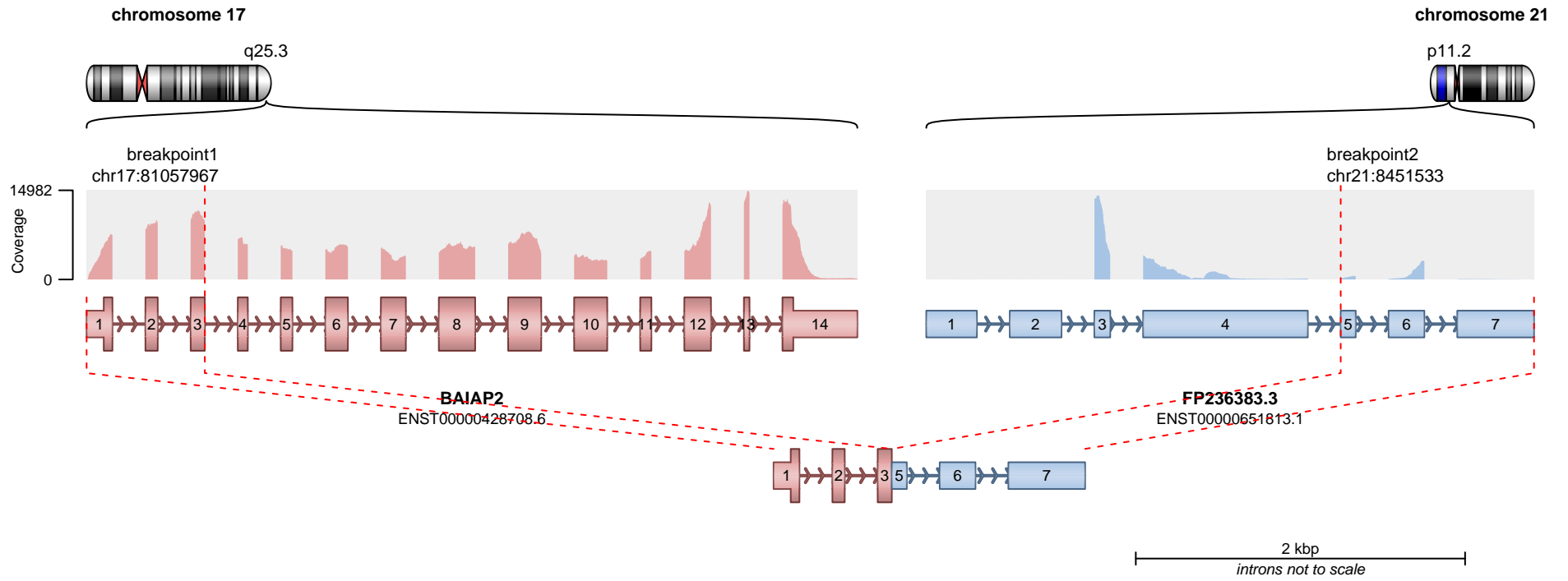

**RETAINED PROTEIN DOMAINS**  
reading frame unclear

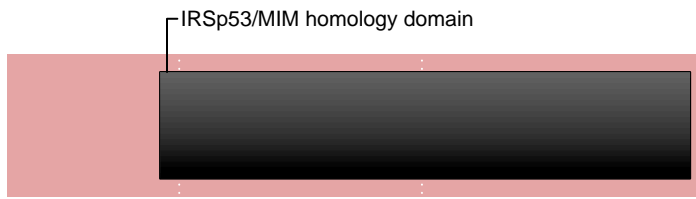

**SUPPORTING READ COUNT**

Split reads = 12  
Discordant mates = 0

- translocation
- duplication
- deletion
- inversion

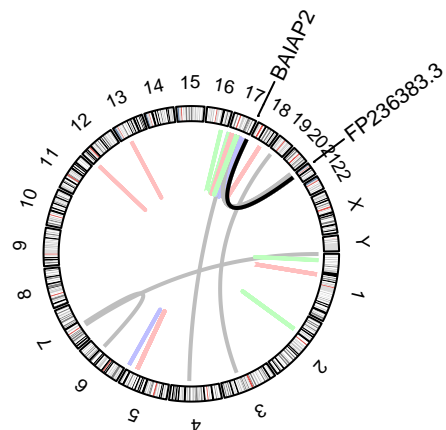
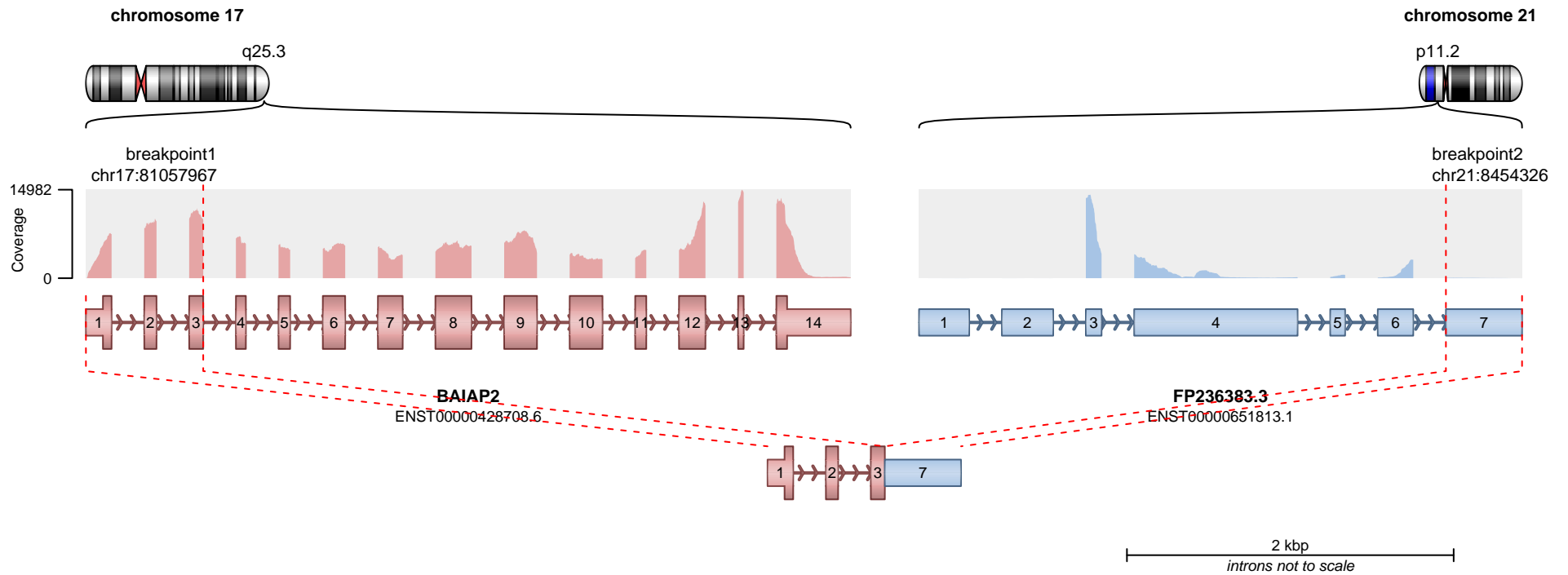

**RETAINED PROTEIN DOMAINS**  
reading frame unclear

IRSp53/MIM homology domain



**BAIAP2**

**SUPPORTING READ COUNT**

Split reads = 2  
Discordant mates = 0

- translocation
- duplication
- deletion
- inversion

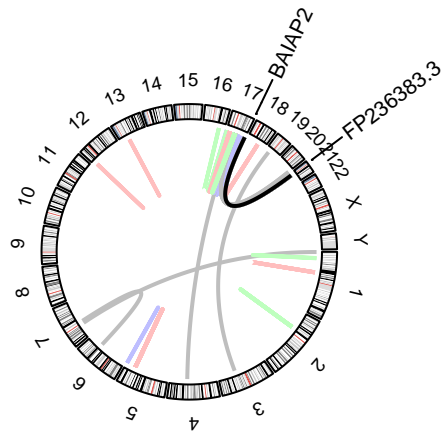
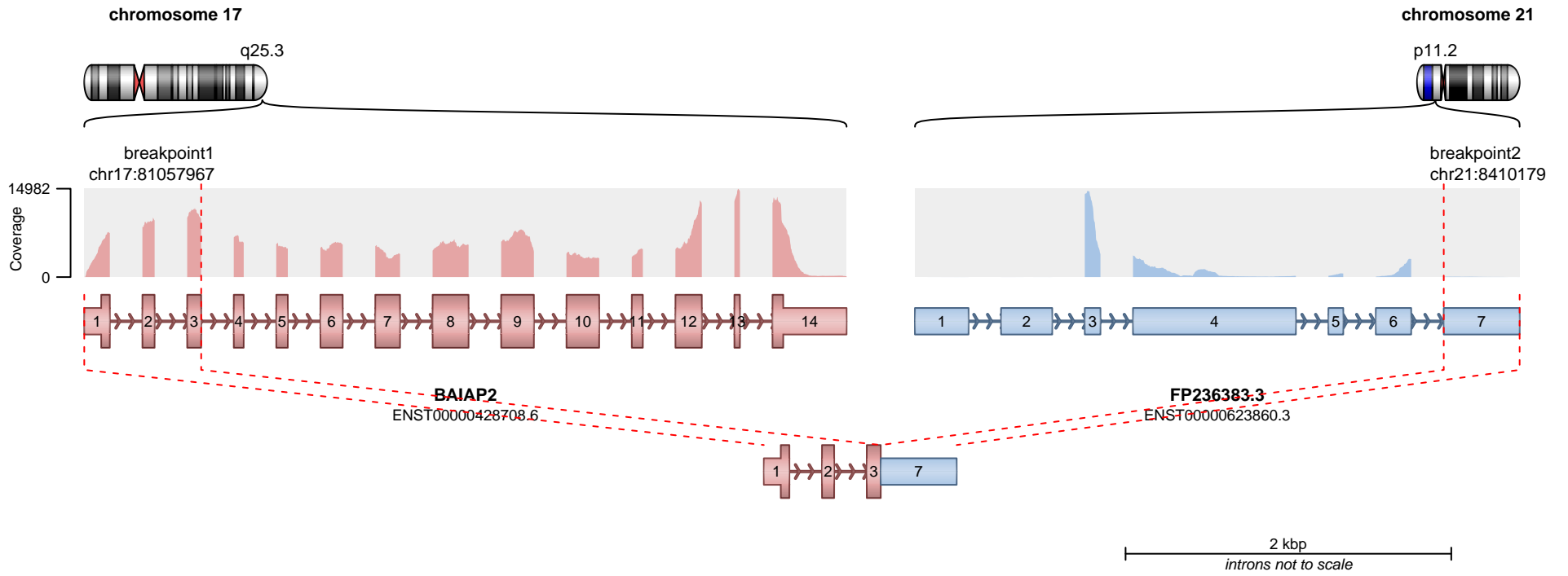

**RETAINED PROTEIN DOMAINS**  
reading frame unclear

IRSp53/MIM homology domain



**BAIAP2**

**SUPPORTING READ COUNT**

Split reads = 2  
Discordant mates = 0

- translocation
- duplication
- deletion
- inversion

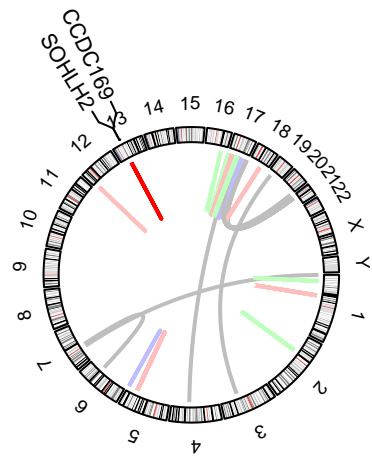
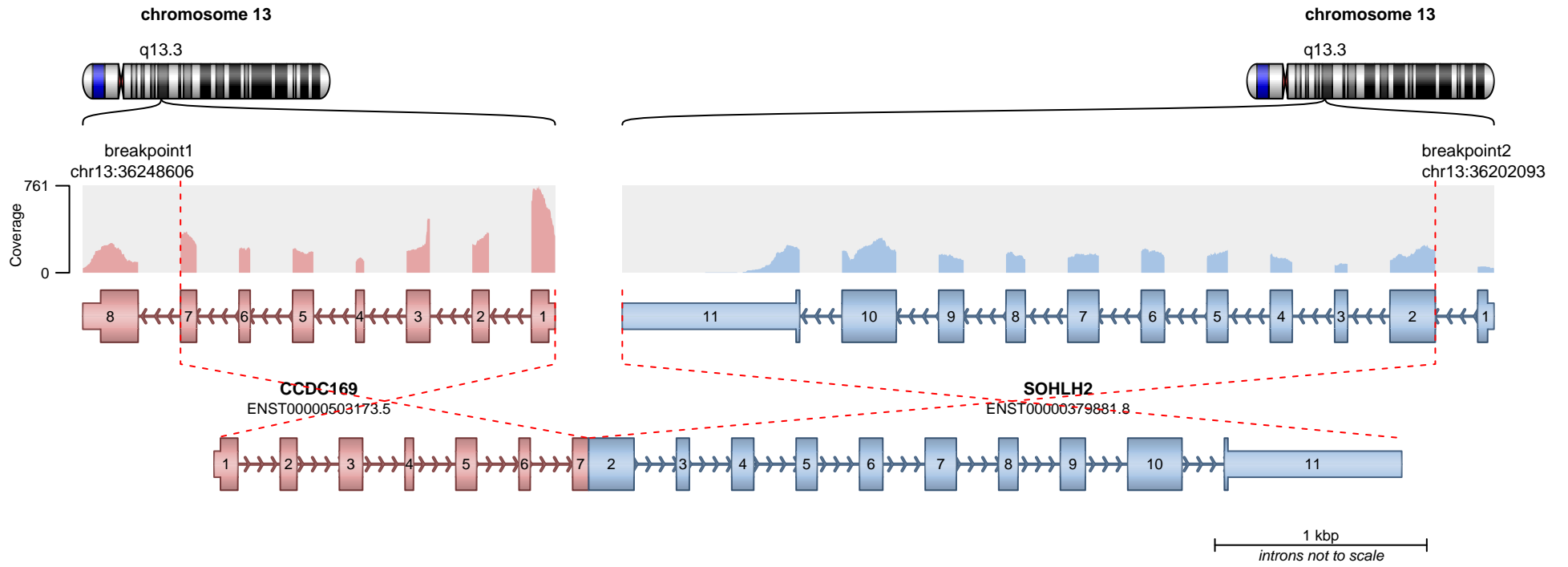

**RETAINED PROTEIN DOMAINS**  
reading frame unclear

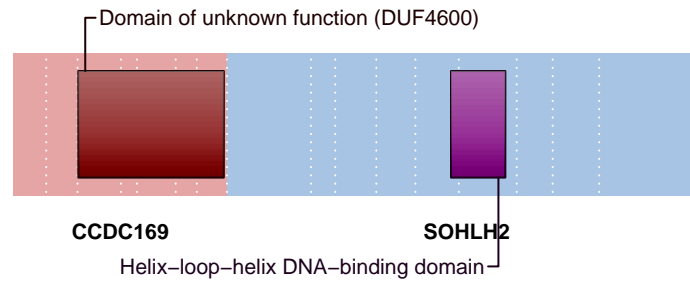

**SUPPORTING READ COUNT**

Split reads = 40  
Discordant mates = 1

— translocation    — deletion  
— duplication    — inversion

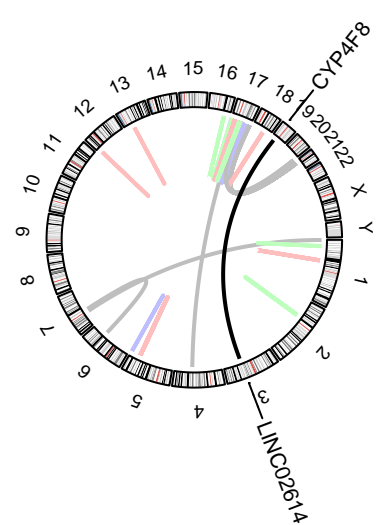
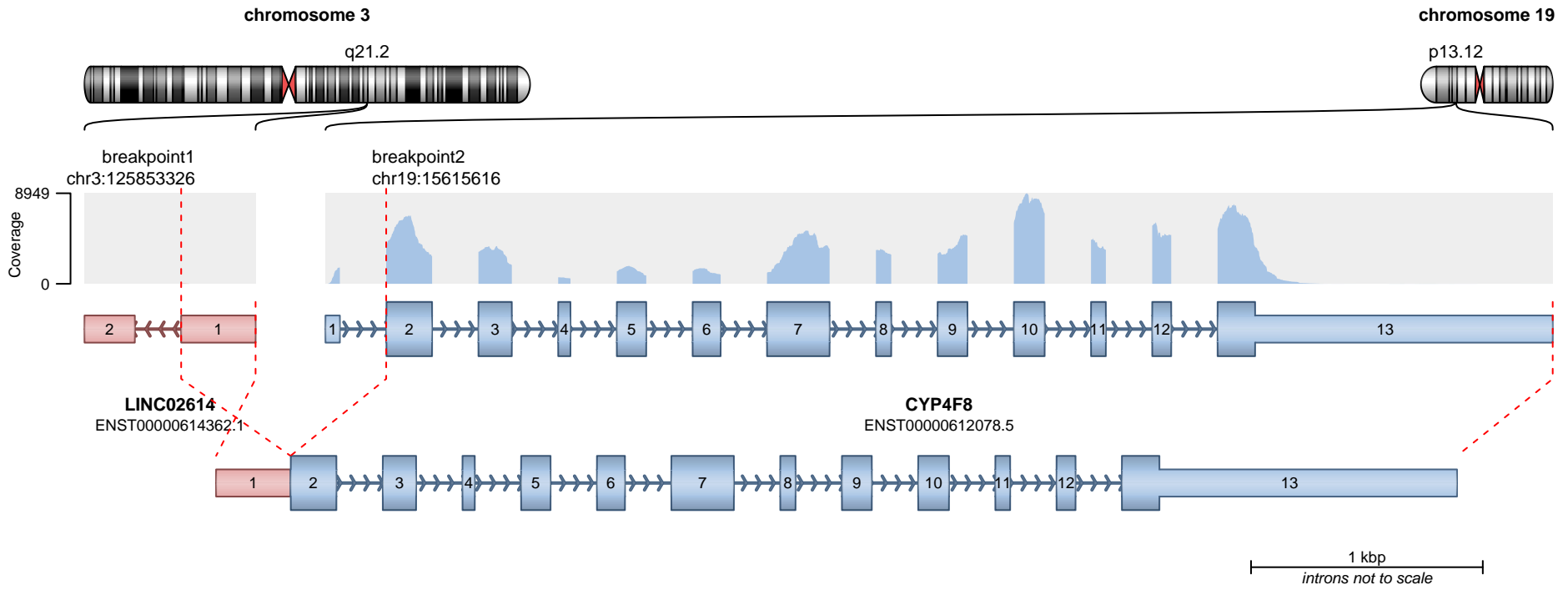

— translocation    — deletion  
— duplication    — inversion

**RETAINED PROTEIN DOMAINS**  
reading frame unclear

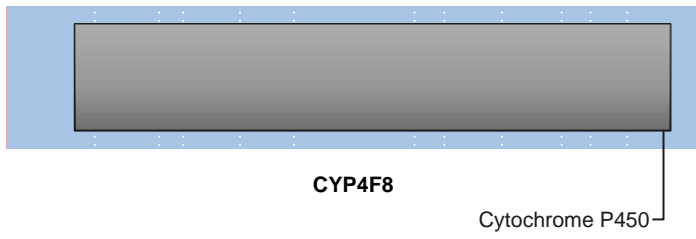

**SUPPORTING READ COUNT**

Split reads = 40  
Discordant mates = 0

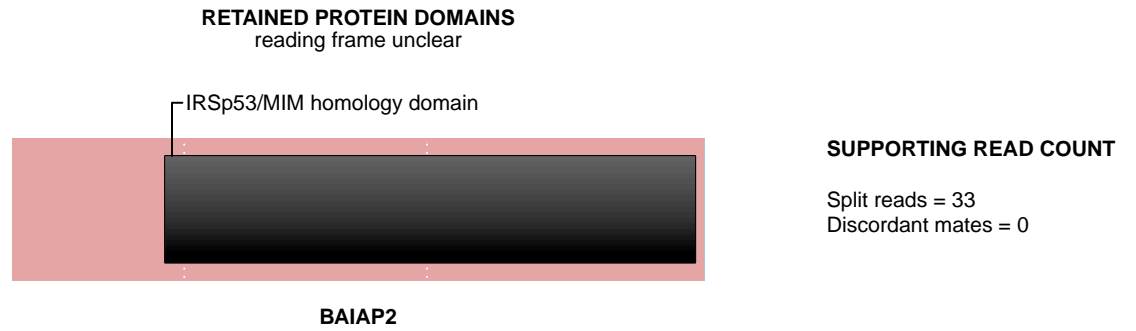
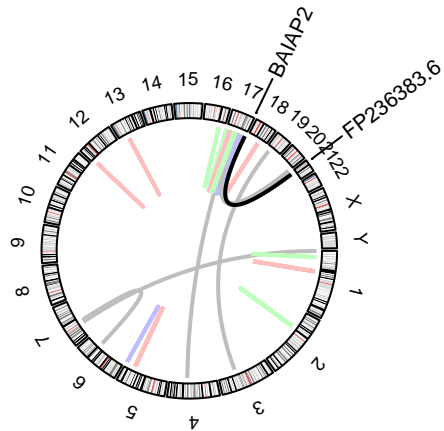
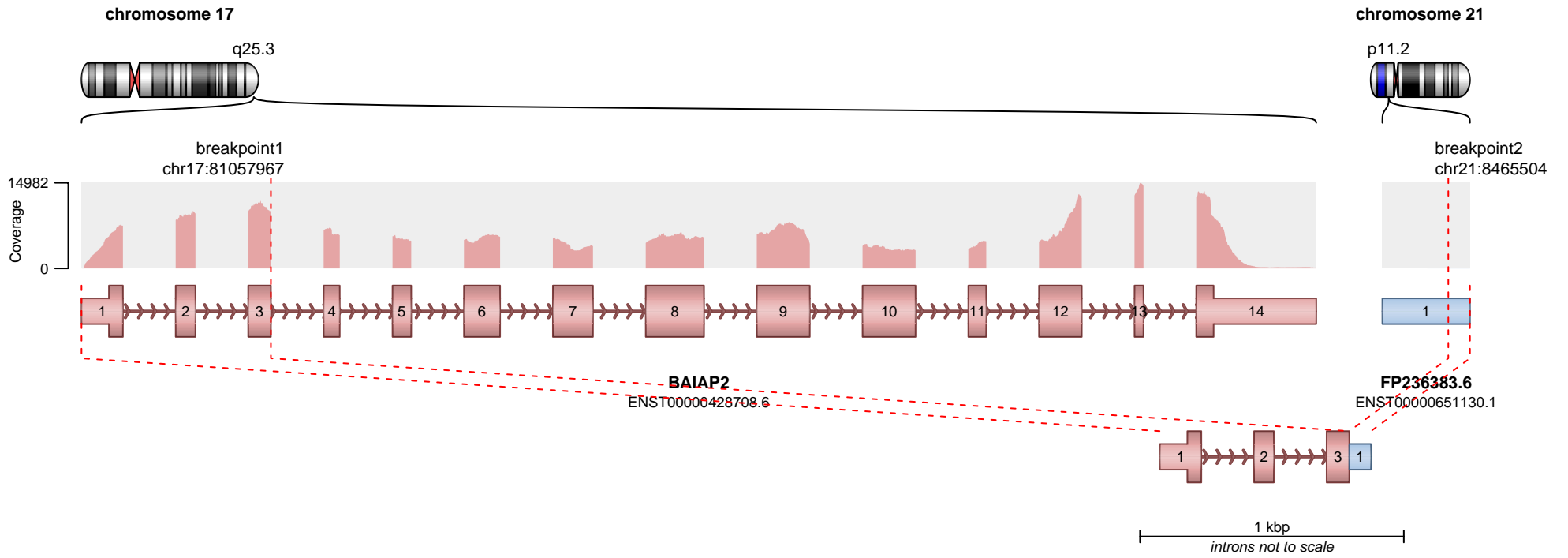

— translocation — deletion  
— duplication — inversion

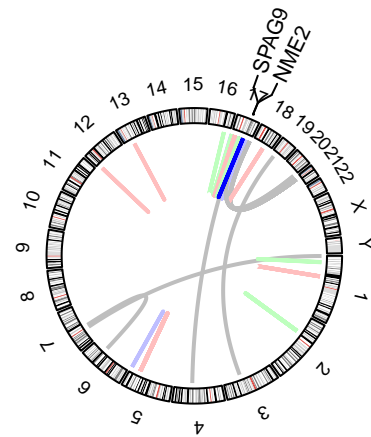
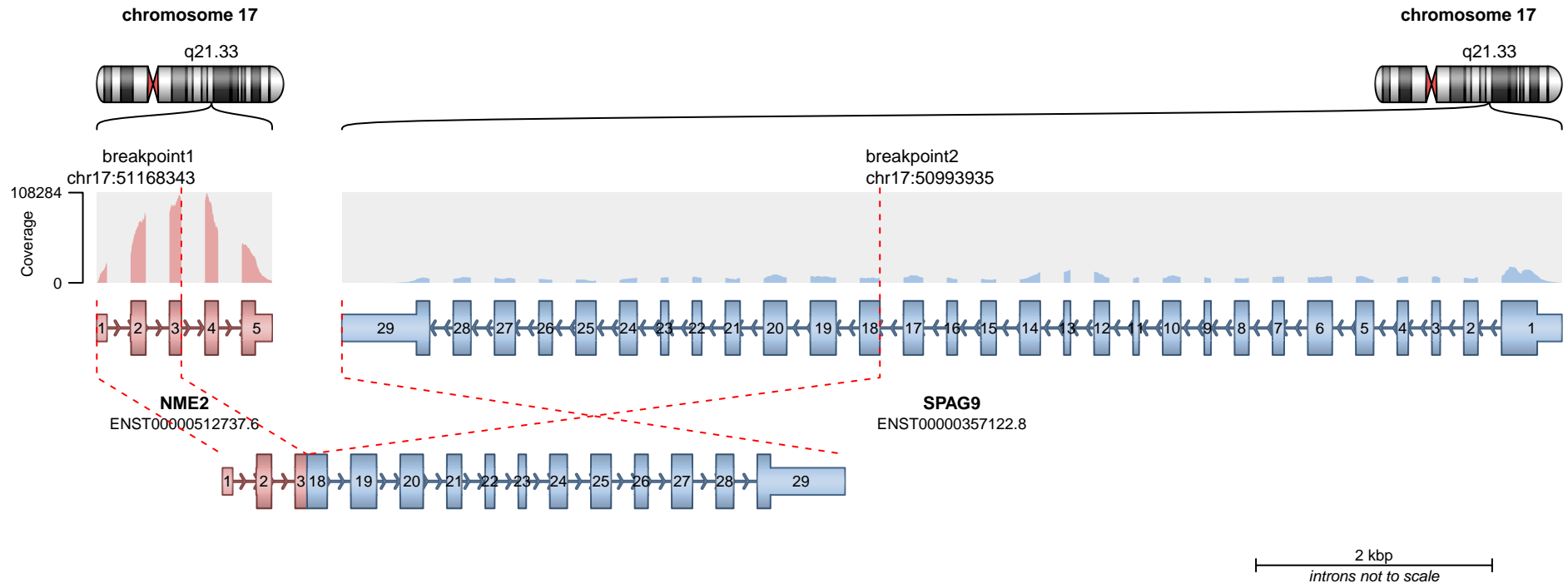

**RETAINED PROTEIN DOMAINS**  
reading frame unclear

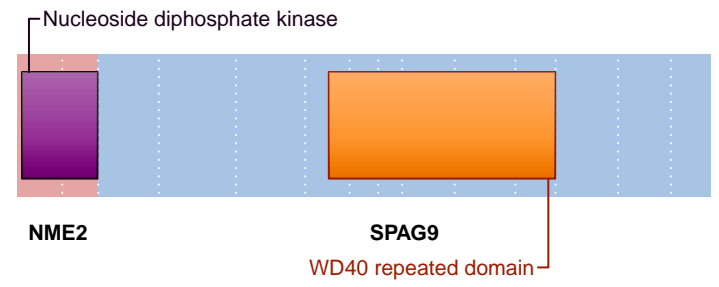

**SUPPORTING READ COUNT**

Split reads = 30  
Discordant mates = 1

- translocation
- duplication
- deletion
- inversion

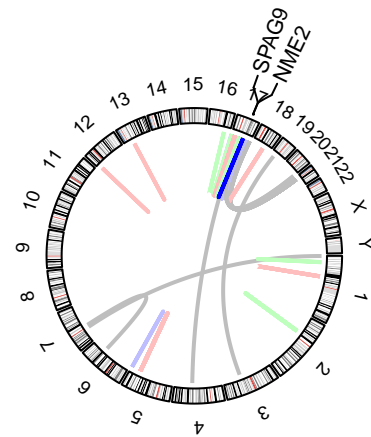
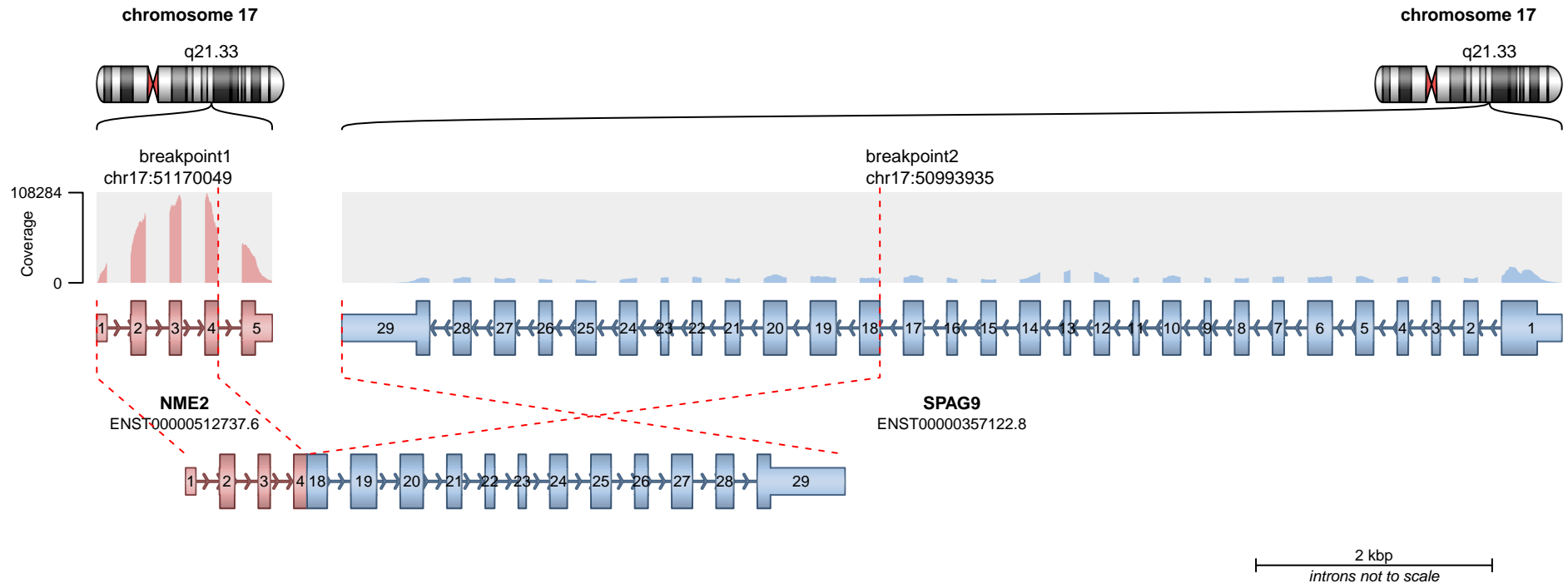

**RETAINED PROTEIN DOMAINS**  
reading frame unclear

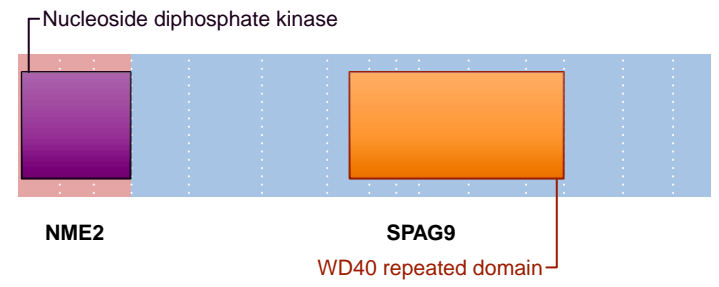

**SUPPORTING READ COUNT**

Split reads = 3  
Discordant mates = 1

- translocation
- duplication
- deletion
- inversion

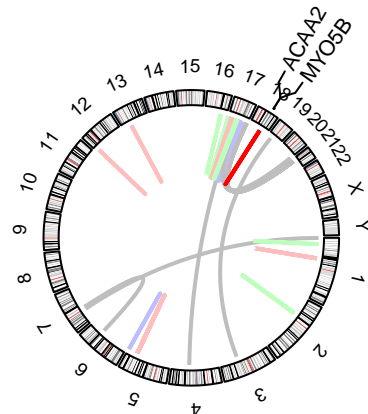
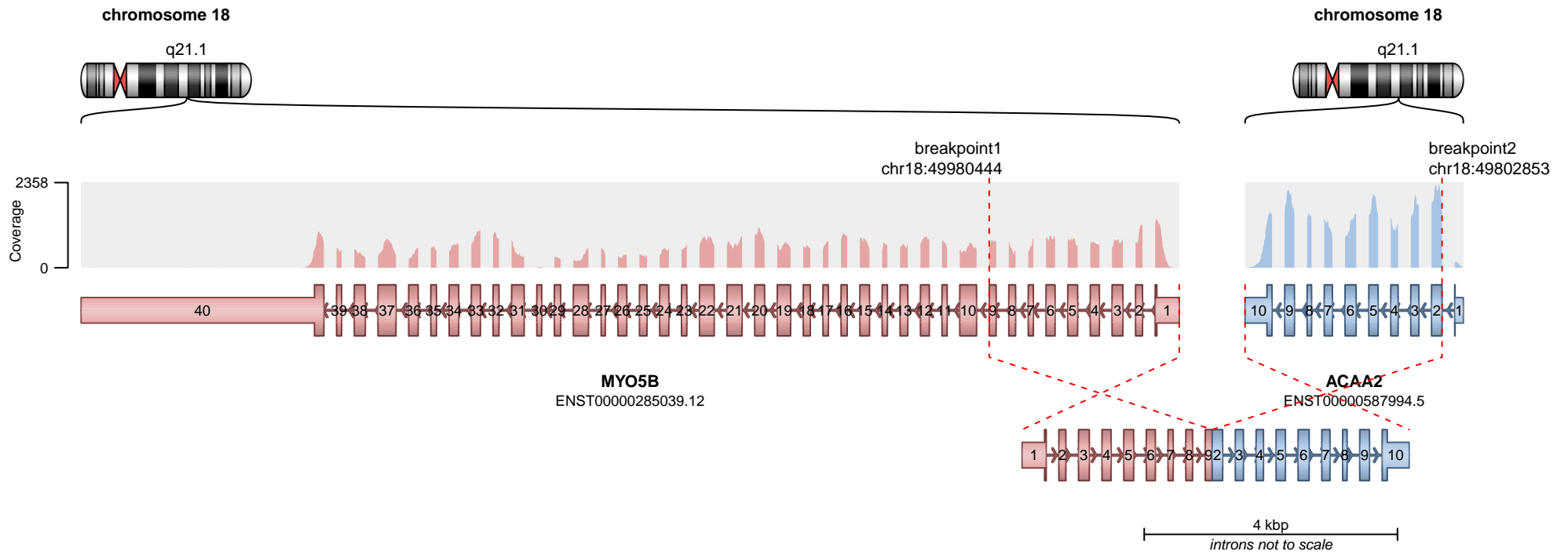

— translocation    — deletion  
— duplication    — inversion

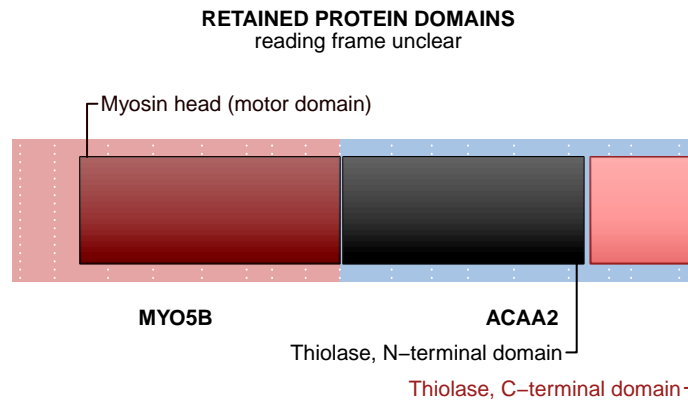

**SUPPORTING READ COUNT**

Split reads = 28  
Discordant mates = 2

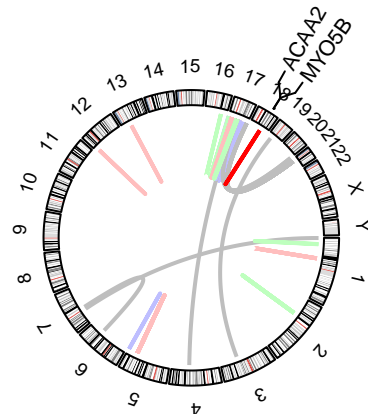
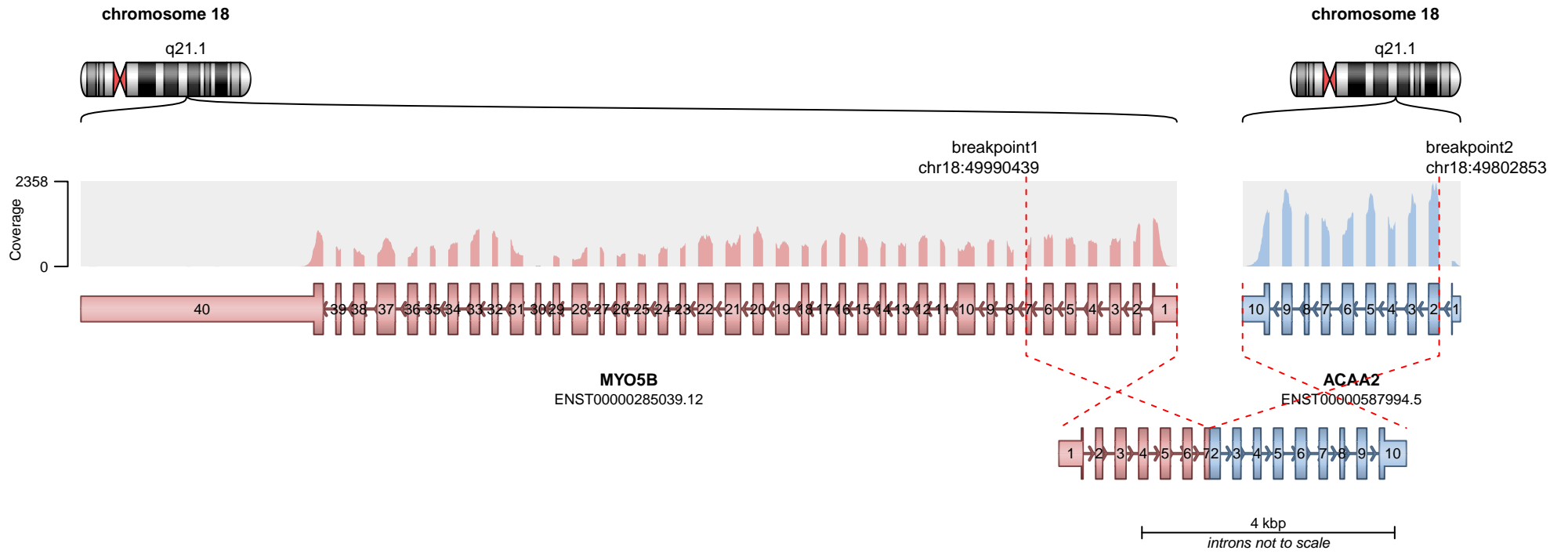

**RETAINED PROTEIN DOMAINS**  
reading frame unclear

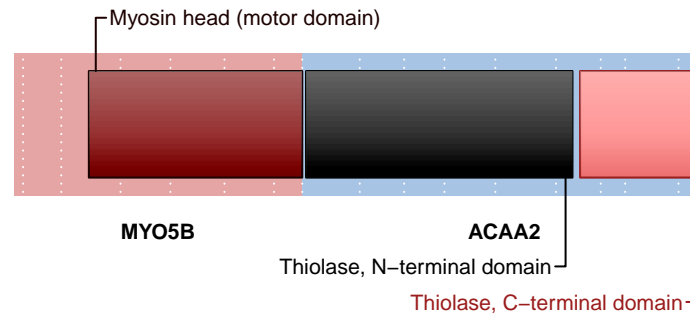

**SUPPORTING READ COUNT**

Split reads = 2  
Discordant mates = 0

- translocation
- duplication
- deletion
- inversion

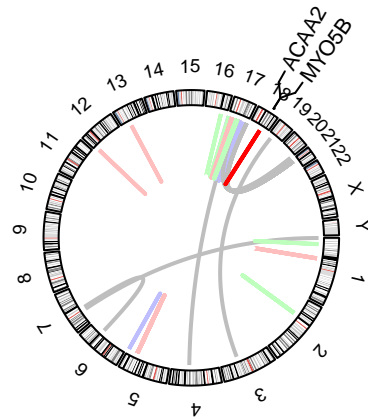
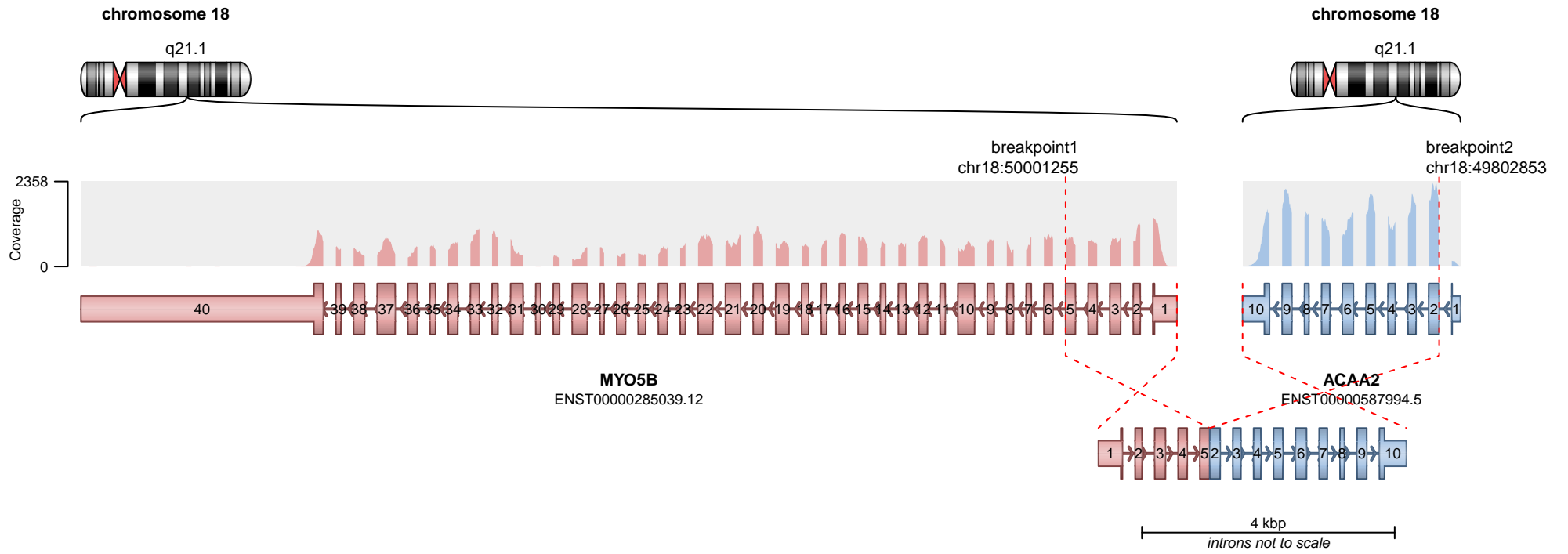

— translocation — deletion  
— duplication — inversion

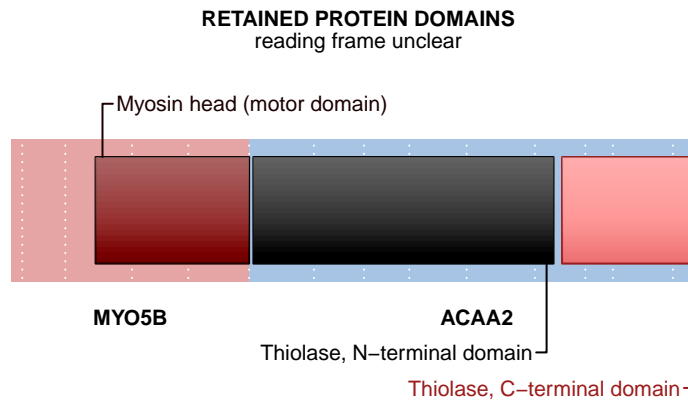

**SUPPORTING READ COUNT**

Split reads = 1  
Discordant mates = 0

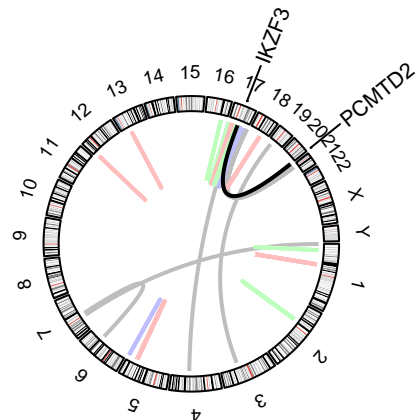
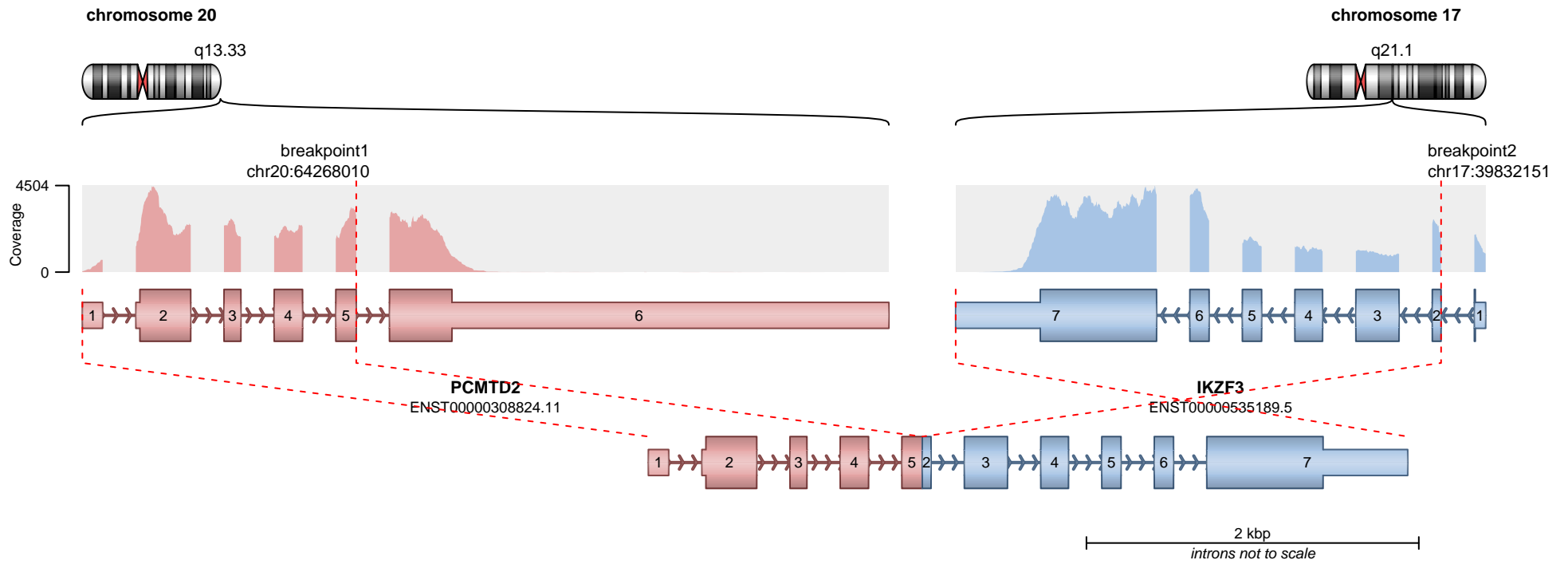

**RETAINED PROTEIN DOMAINS**  
reading frame unclear

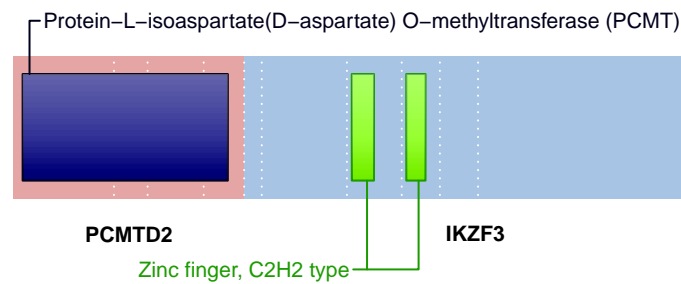

**SUPPORTING READ COUNT**

Split reads = 25  
Discordant mates = 1

- translocation
- duplication
- deletion
- inversion

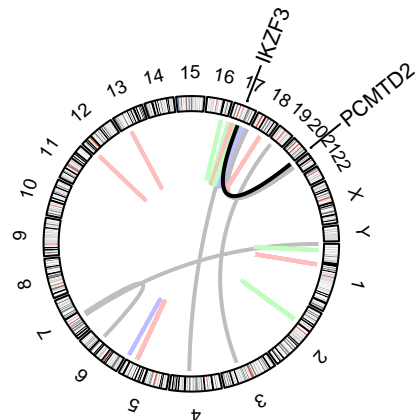
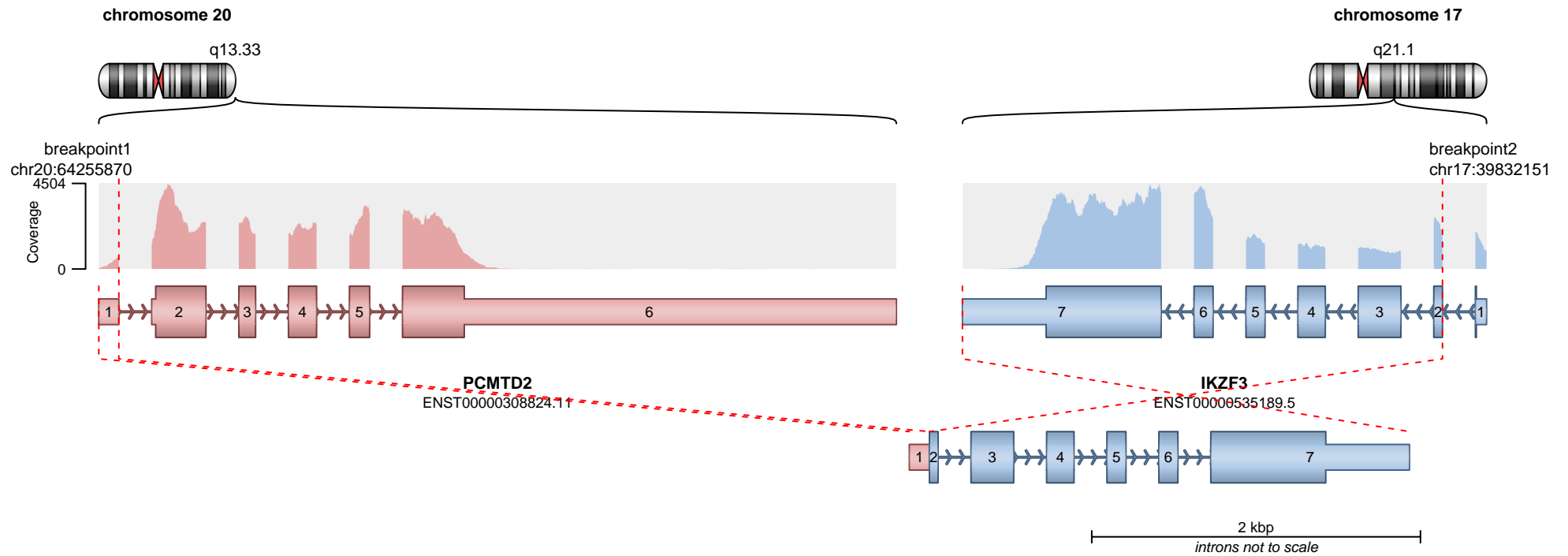

**RETAINED PROTEIN DOMAINS**  
reading frame unclear

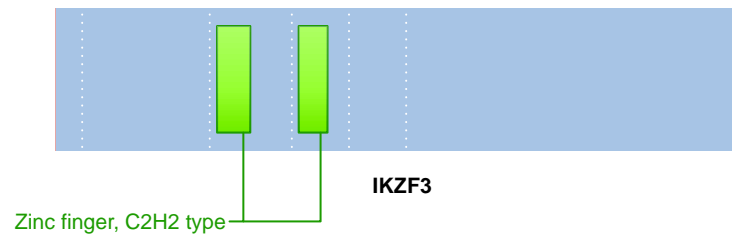

**SUPPORTING READ COUNT**

Split reads = 5  
Discordant mates = 0

- translocation
- duplication
- deletion
- inversion

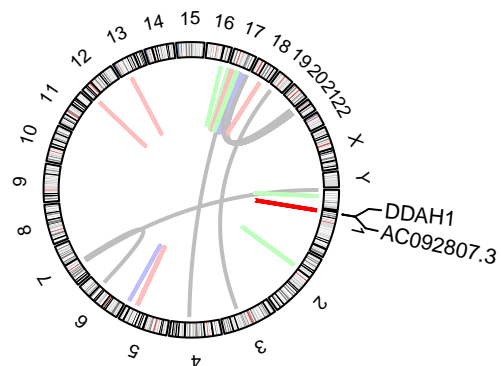
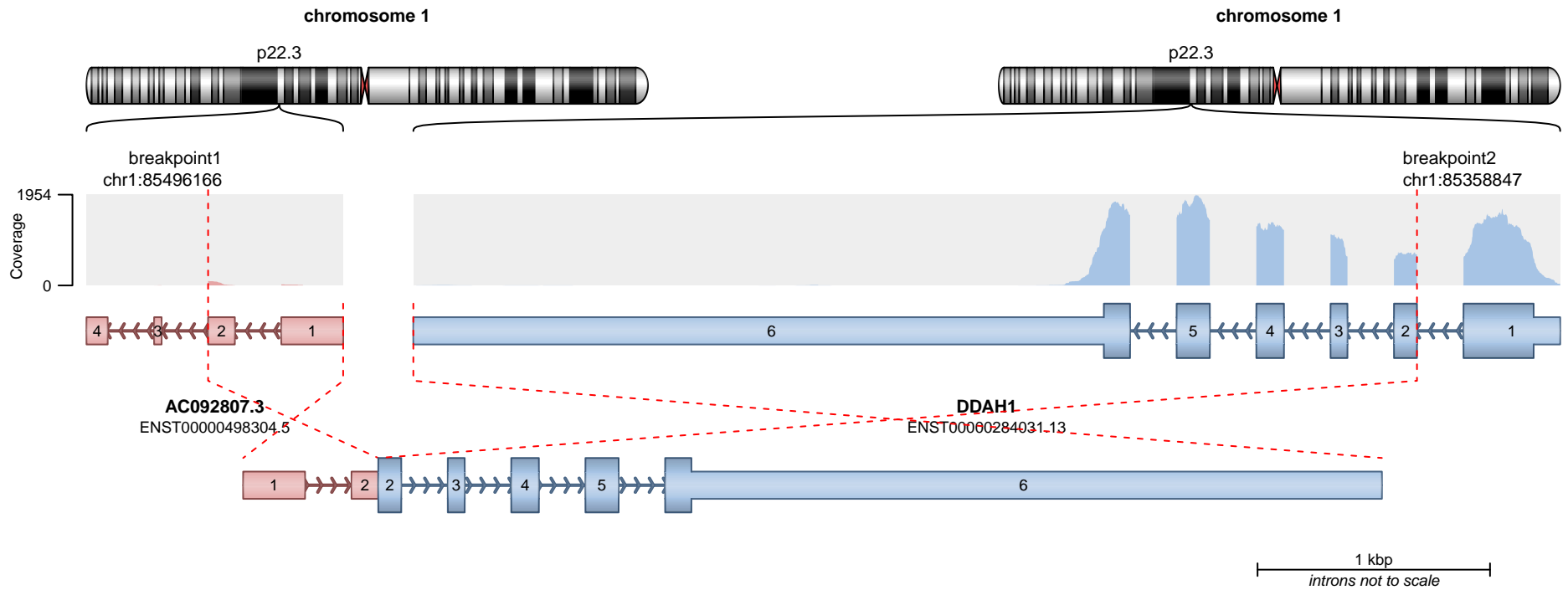

**RETAINED PROTEIN DOMAINS**  
reading frame unclear

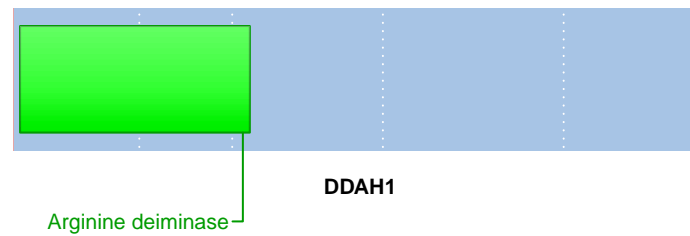

**SUPPORTING READ COUNT**

Split reads = 21  
Discordant mates = 0

- translocation
- duplication
- deletion
- inversion

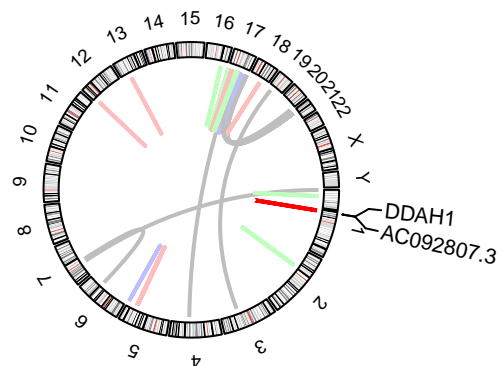
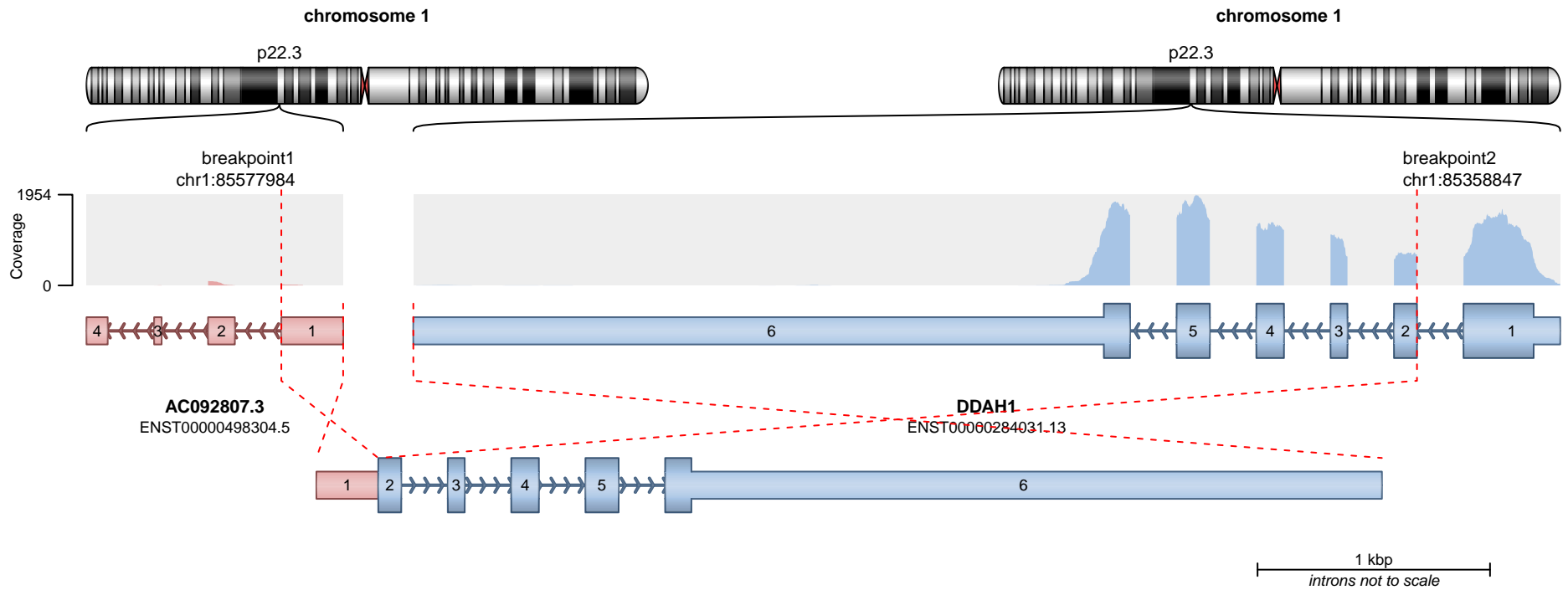

**RETAINED PROTEIN DOMAINS**  
reading frame unclear

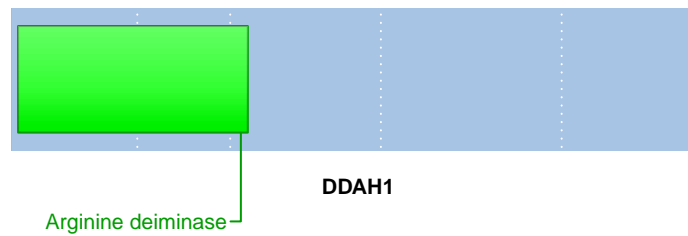

**SUPPORTING READ COUNT**

Split reads = 7  
Discordant mates = 0

- translocation
- duplication
- deletion
- inversion

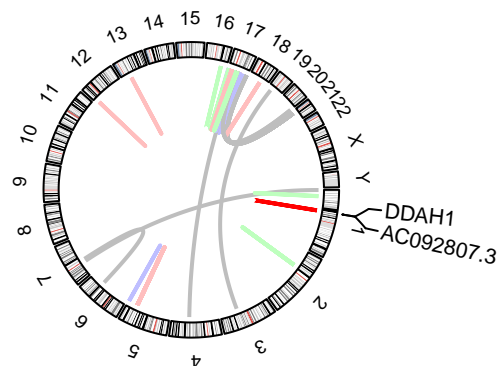
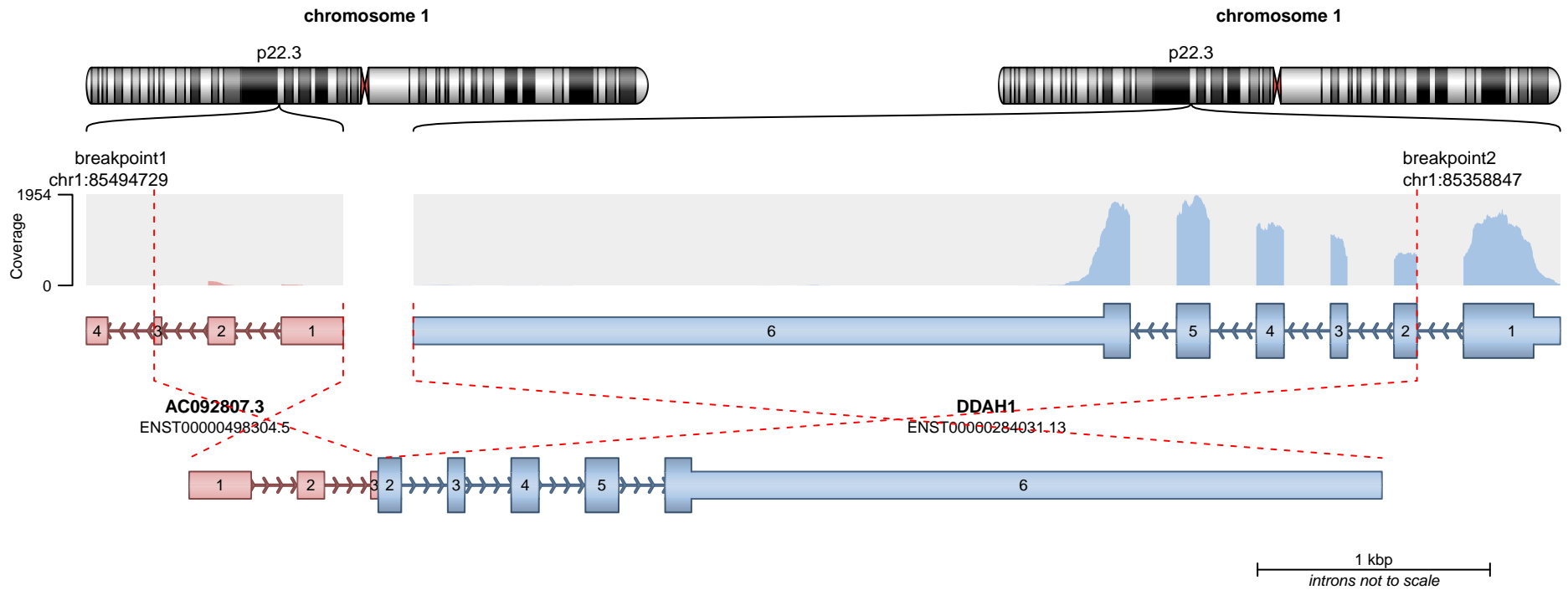

**RETAINED PROTEIN DOMAINS**  
reading frame unclear

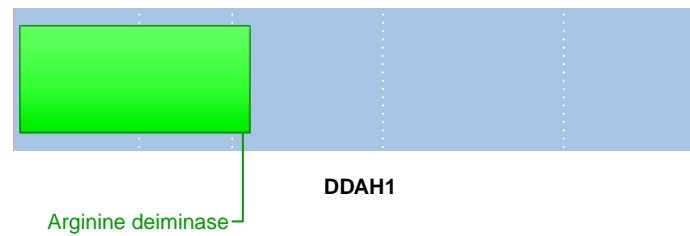

**SUPPORTING READ COUNT**

Split reads = 1  
Discordant mates = 0

- translocation
- duplication
- deletion
- inversion

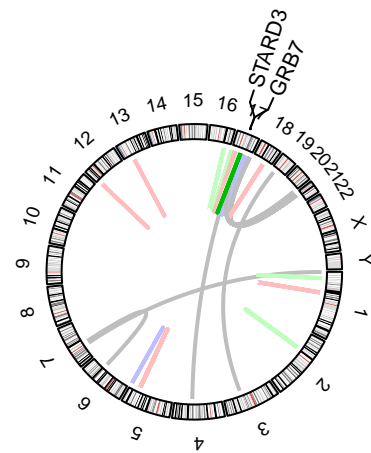
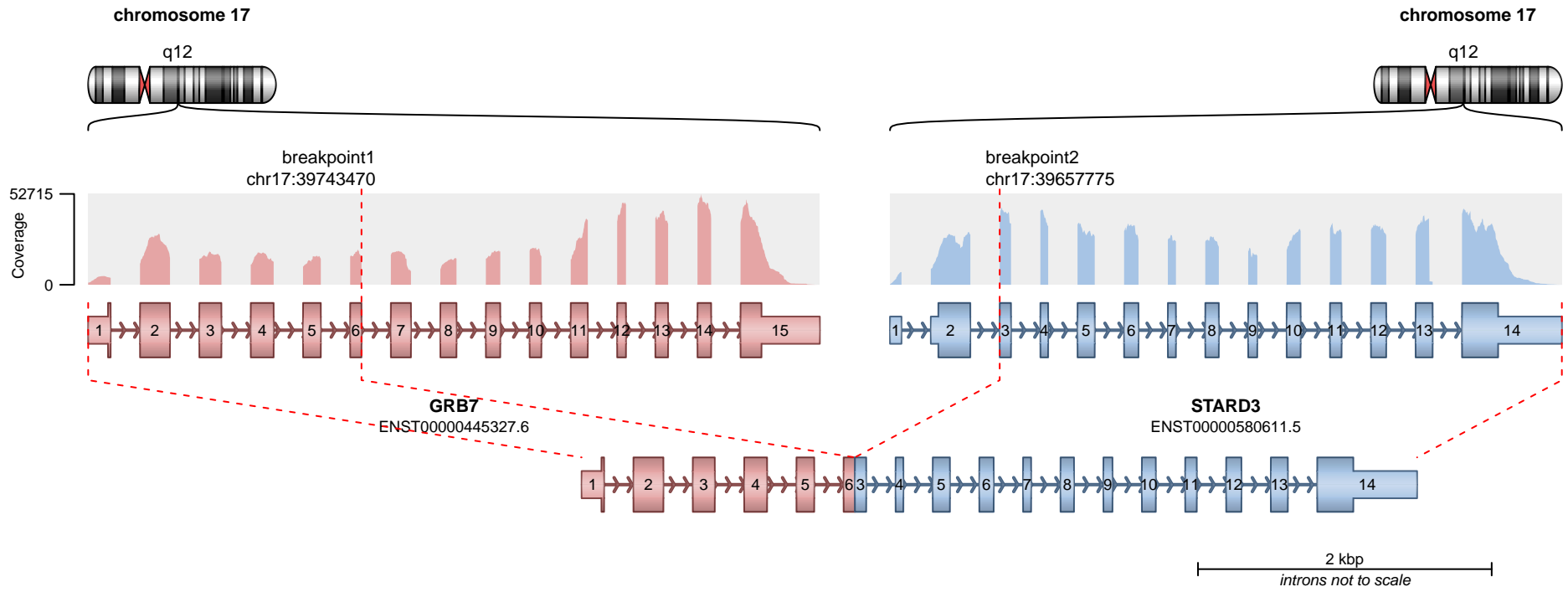

**RETAINED PROTEIN DOMAINS**  
reading frame unclear

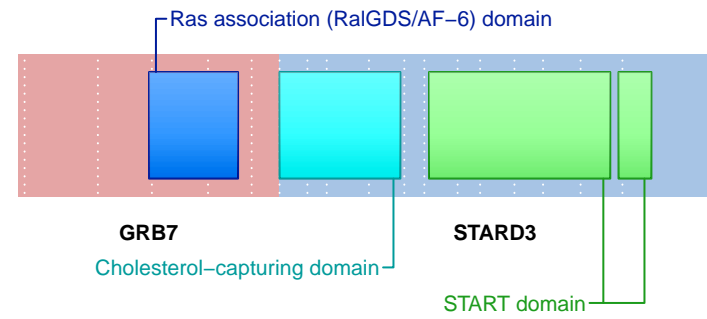

**SUPPORTING READ COUNT**

Split reads = 21  
Discordant mates = 0

- translocation
- duplication
- deletion
- inversion

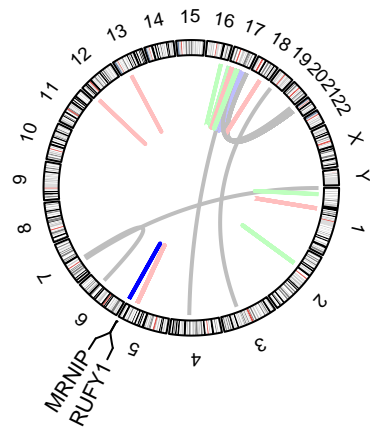
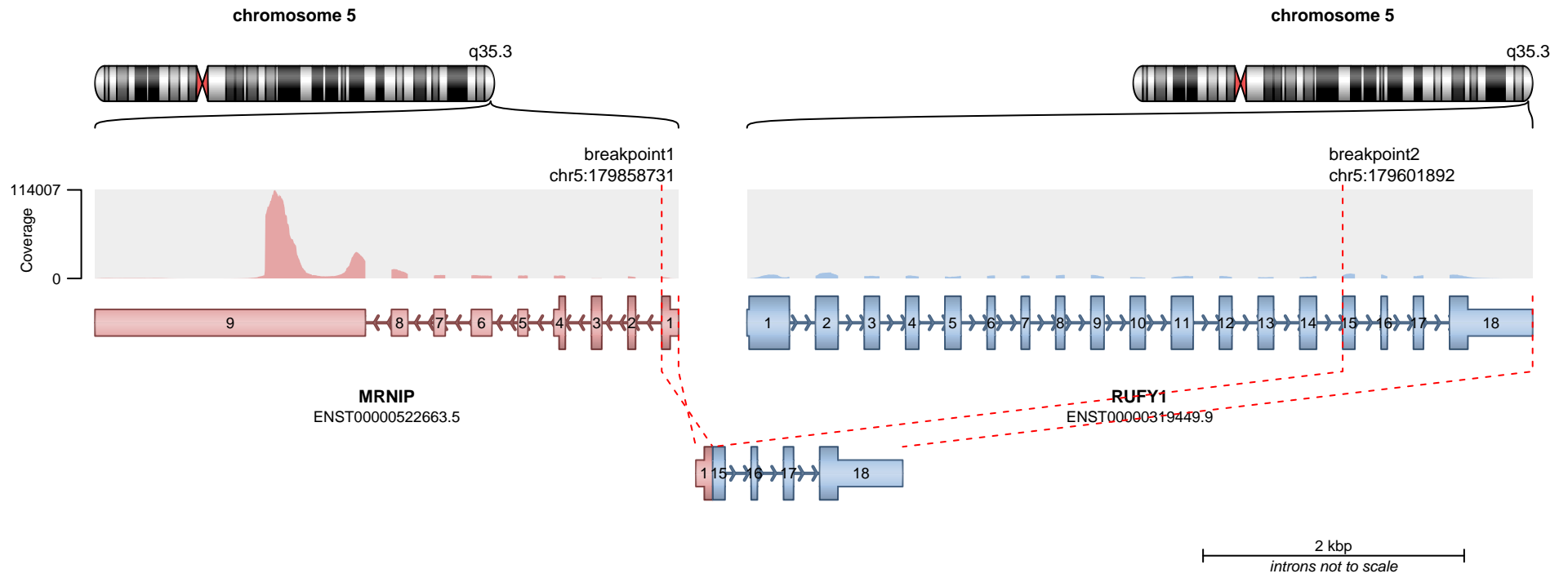

**RETAINED PROTEIN DOMAINS**  
reading frame unclear

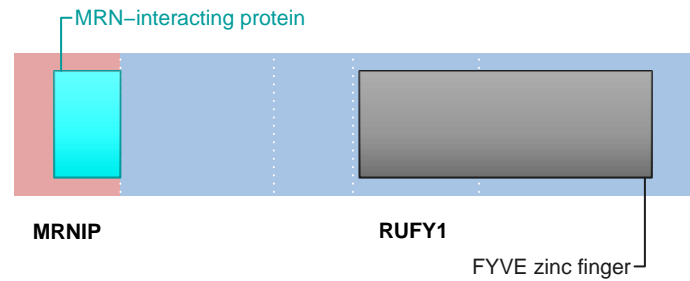

**SUPPORTING READ COUNT**

Split reads = 19  
Discordant mates = 0

— translocation    — deletion  
— duplication    — inversion

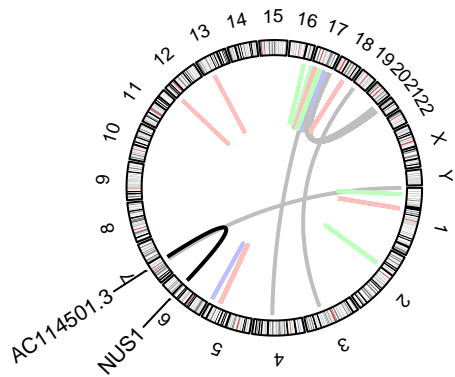
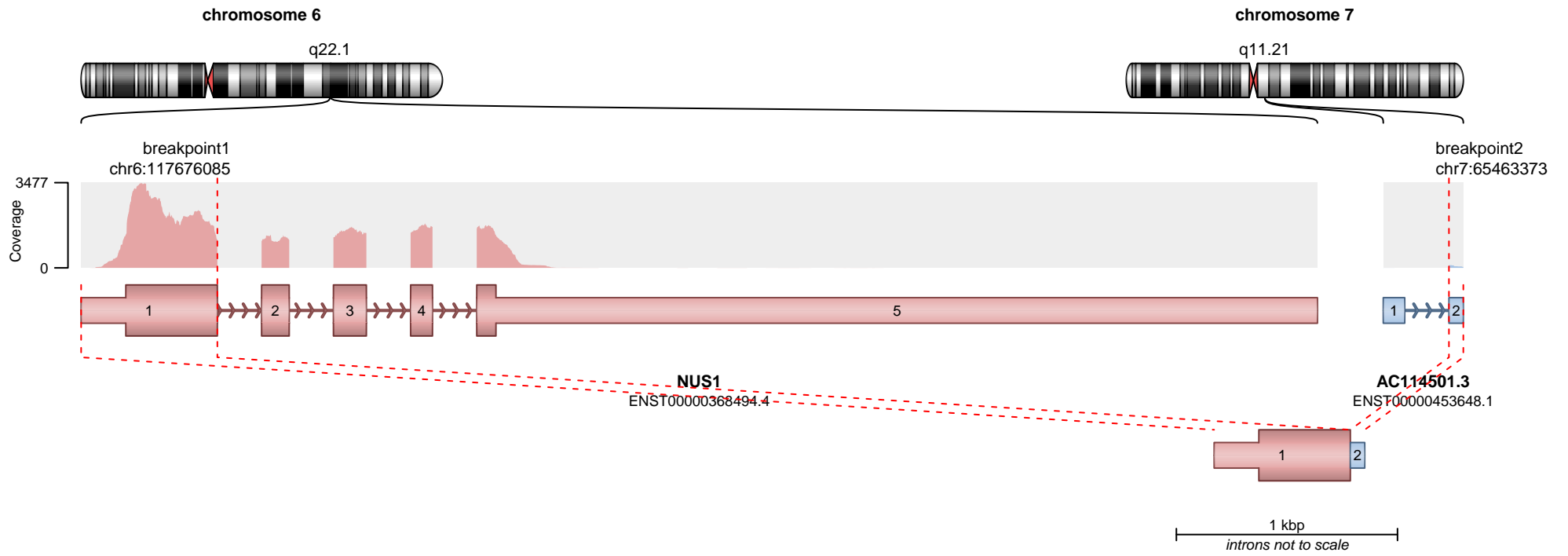

No protein domains retained in fusion.

**SUPPORTING READ COUNT**

Split reads = 19  
Discordant mates = 0

— translocation    — deletion  
— duplication    — inversion

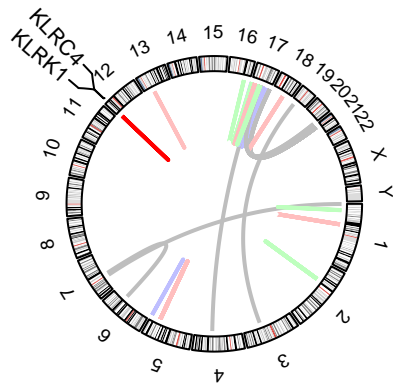
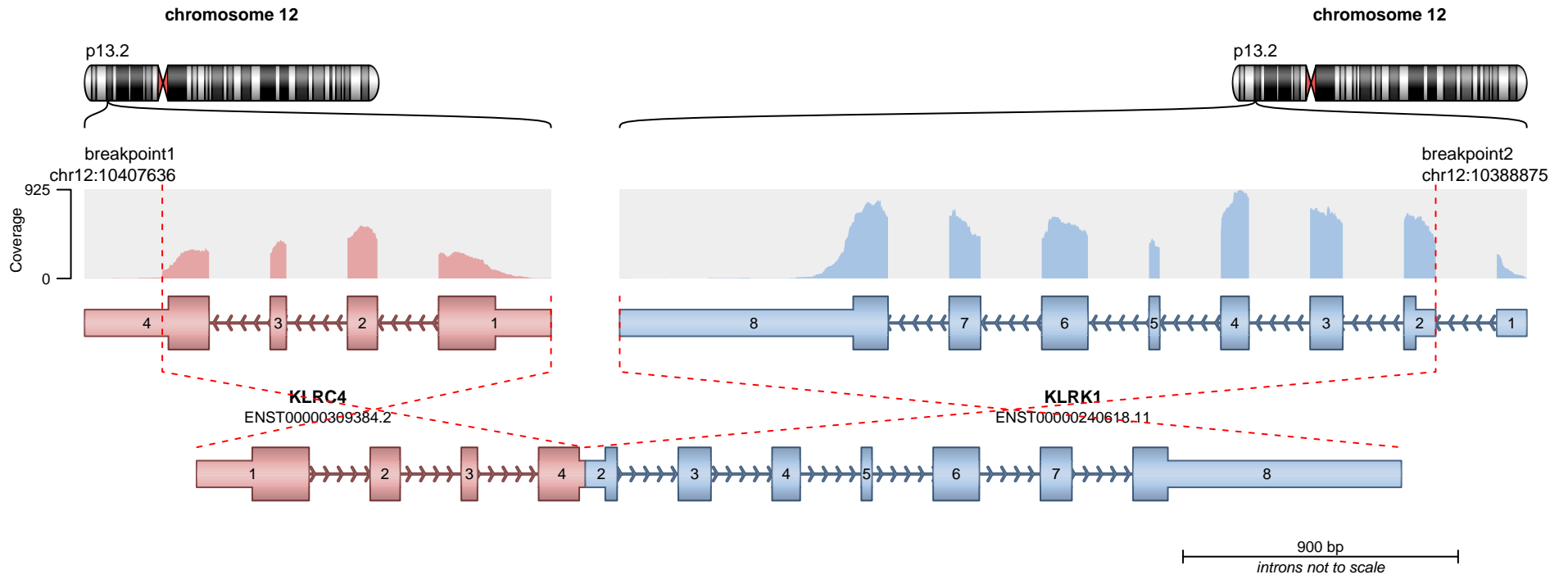

**RETAINED PROTEIN DOMAINS**  
reading frame unclear

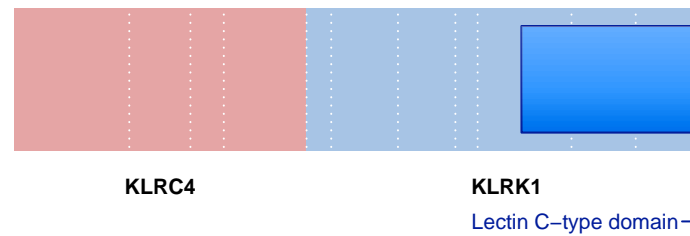

**SUPPORTING READ COUNT**

Split reads = 17  
Discordant mates = 1

— translocation — deletion  
— duplication — inversion

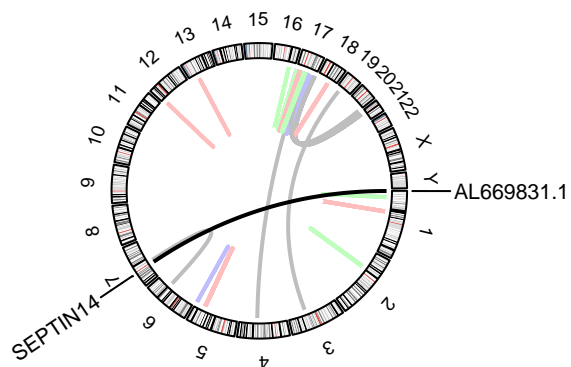
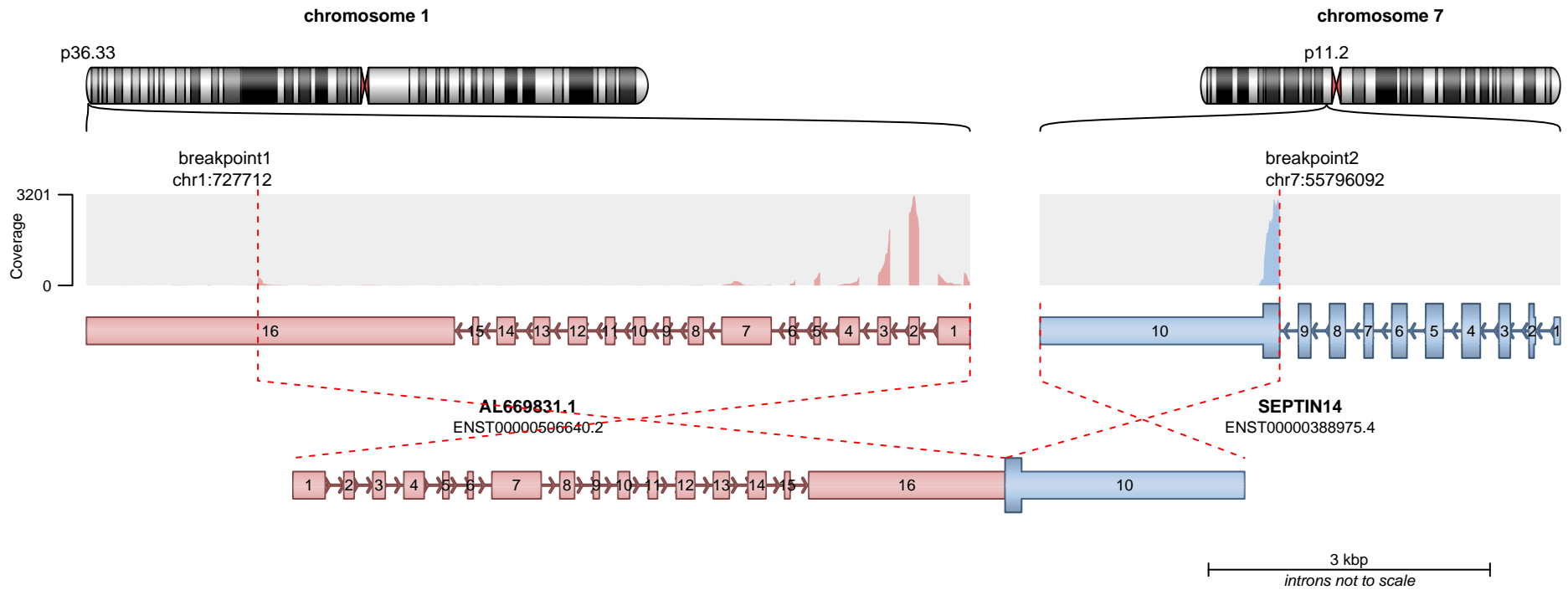

No protein domains retained in fusion.

**SUPPORTING READ COUNT**

Split reads = 15  
Discordant mates = 1

- translocation
- duplication
- deletion
- inversion

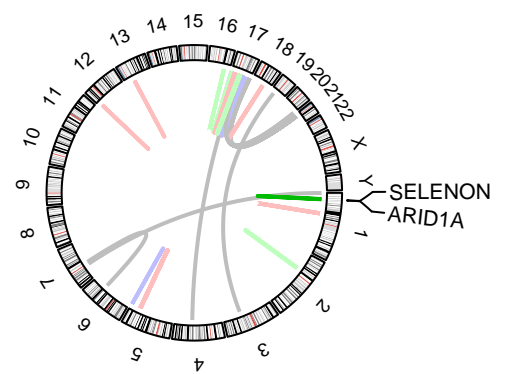
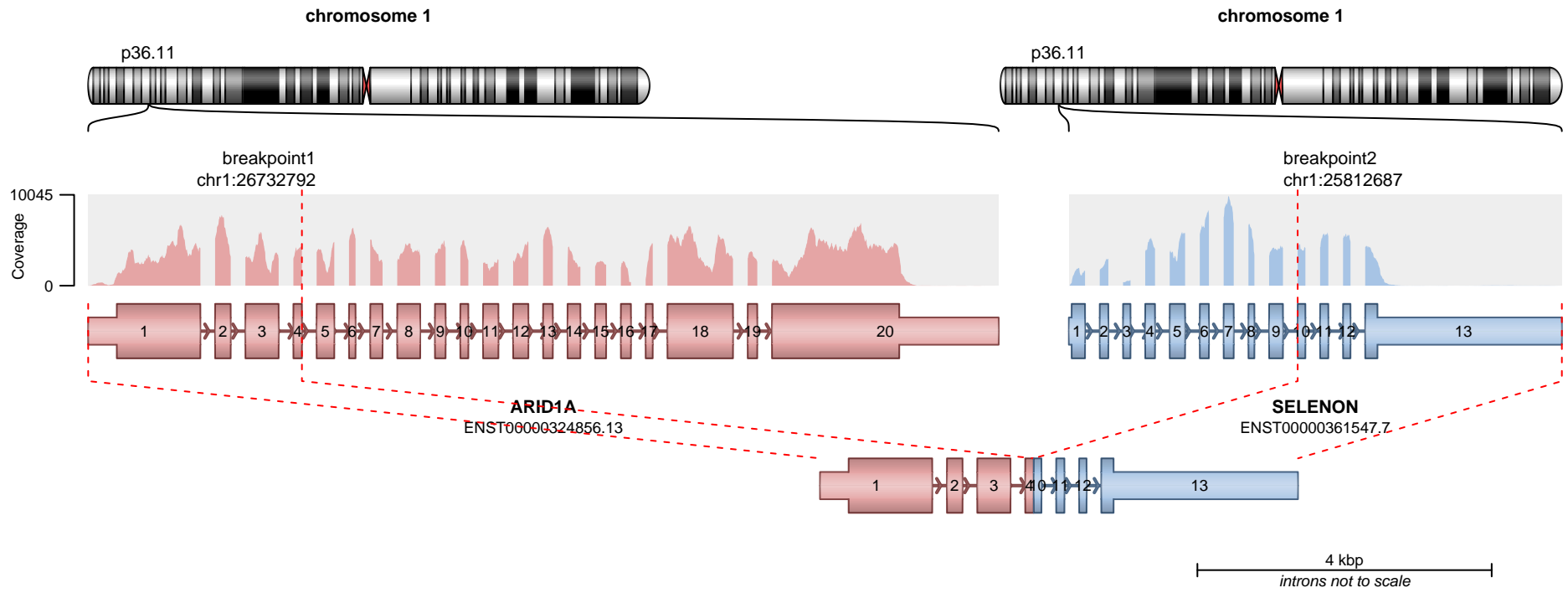

No protein domains retained in fusion.

**SUPPORTING READ COUNT**

Split reads = 14  
Discordant mates = 0

- translocation
- duplication
- deletion
- inversion

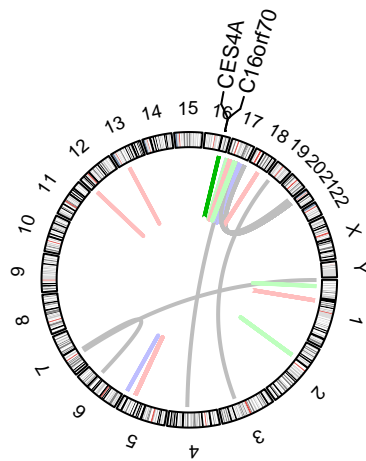
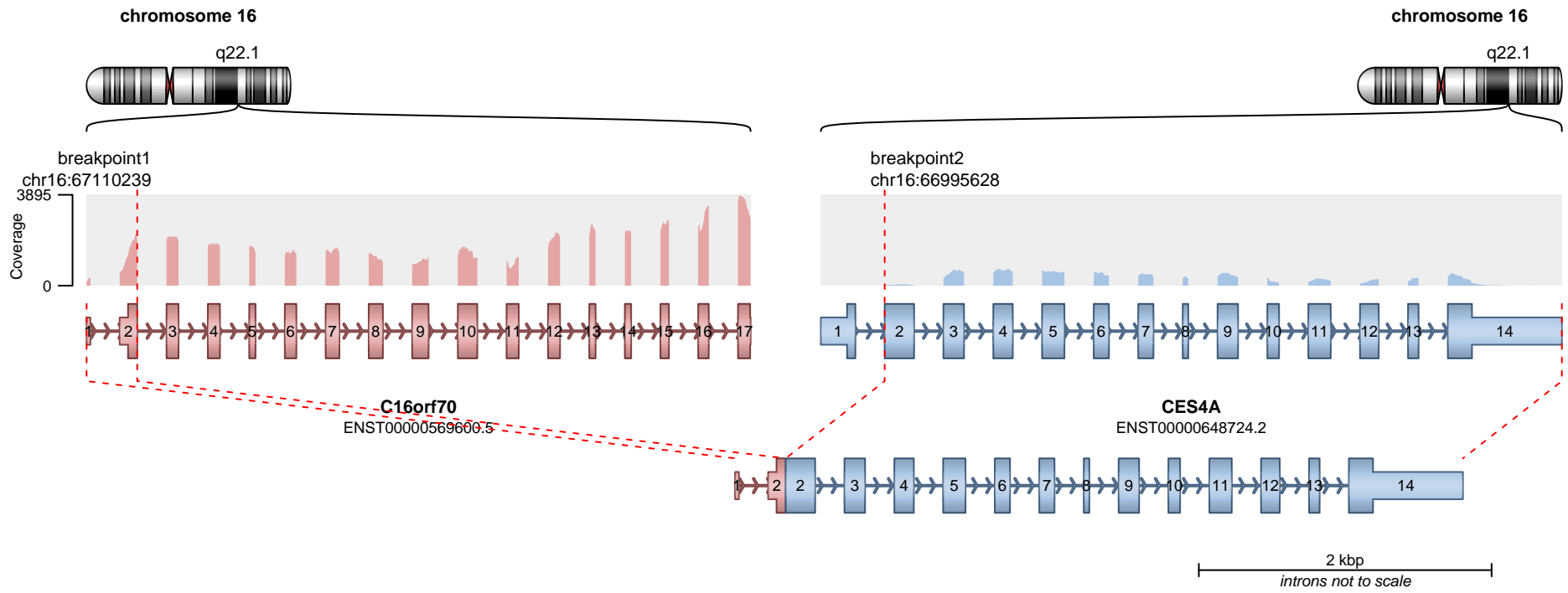

**RETAINED PROTEIN DOMAINS**  
reading frame unclear

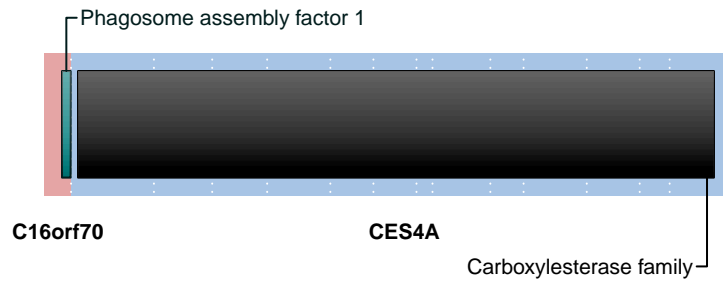

**SUPPORTING READ COUNT**

Split reads = 12  
Discordant mates = 0

- translocation
- duplication
- deletion
- inversion

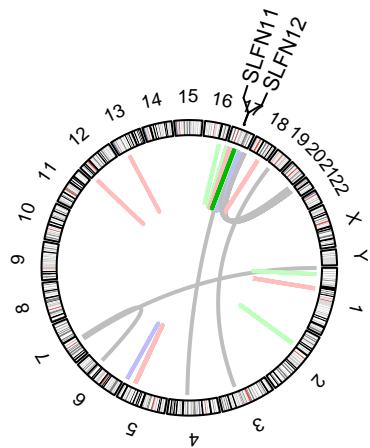
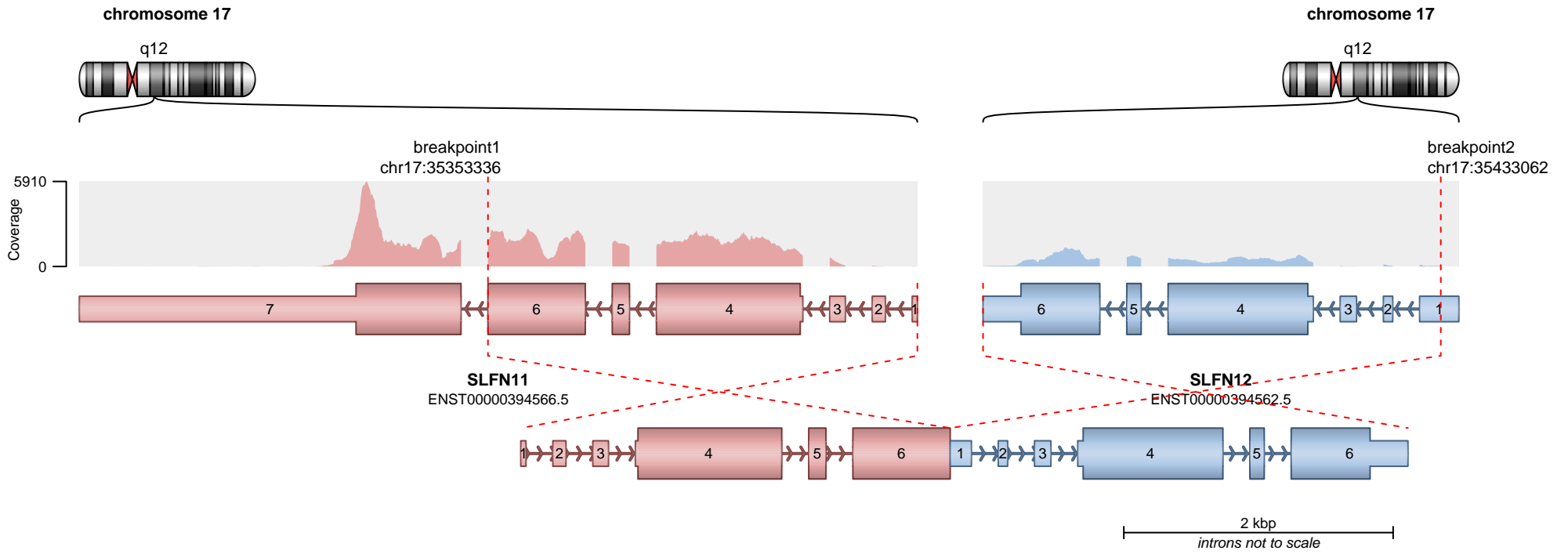

**RETAINED PROTEIN DOMAINS**  
reading frame unclear

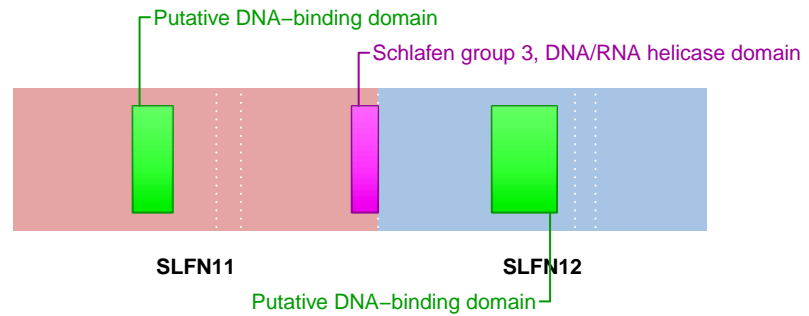

**SUPPORTING READ COUNT**

Split reads = 10  
Discordant mates = 0

— translocation    — deletion  
— duplication    — inversion