

**RETAINED PROTEIN DOMAINS**  
reading frame unclear

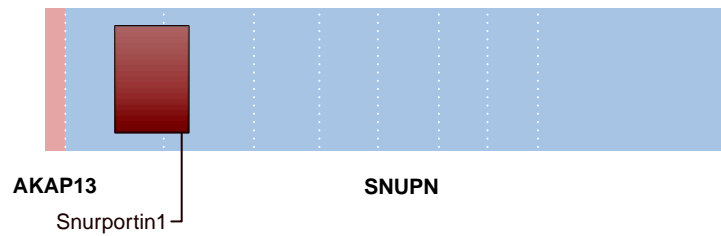

**SUPPORTING READ COUNT**

Split reads = 1039  
Discordant mates = 0

- translocation
- duplication
- deletion
- inversion

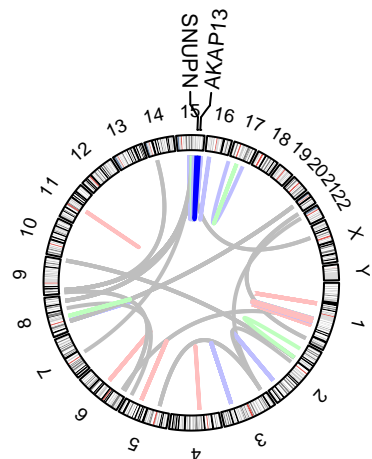
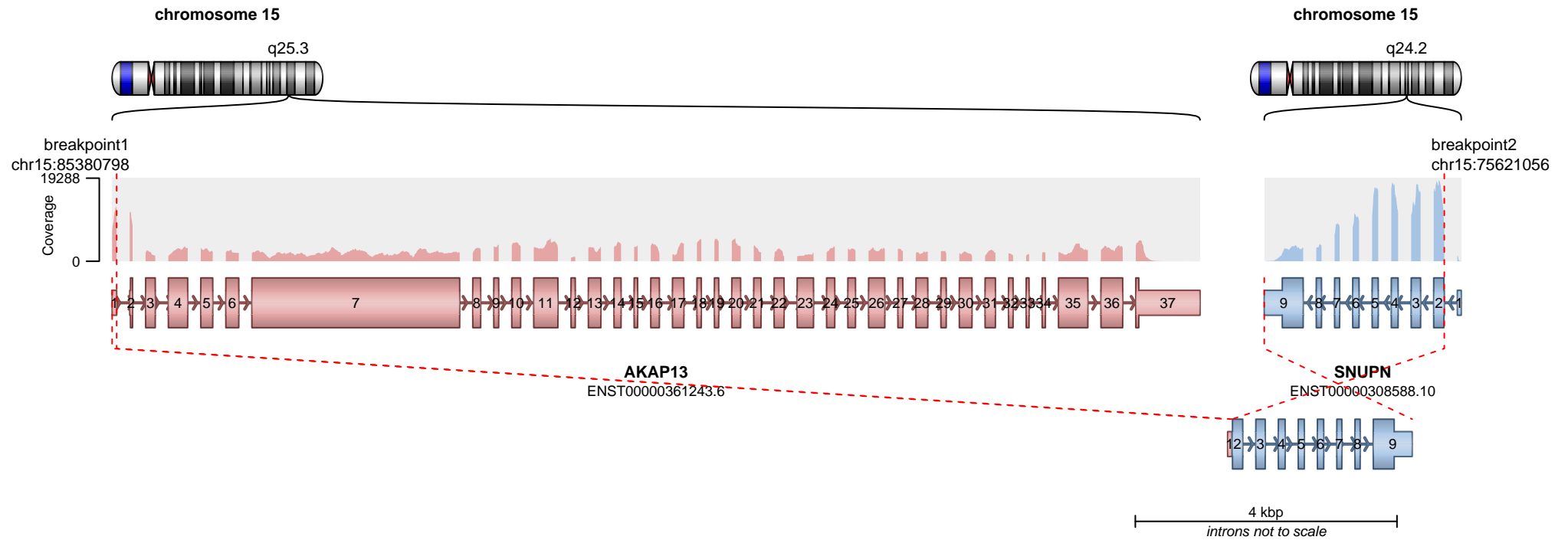

**RETAINED PROTEIN DOMAINS**  
reading frame unclear

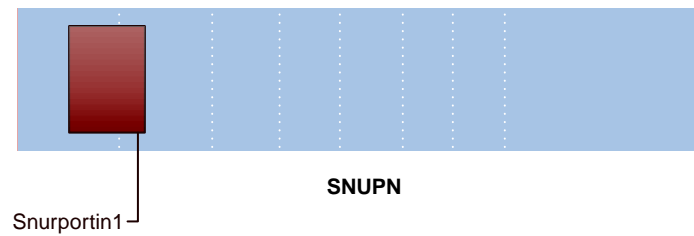

**SUPPORTING READ COUNT**

Split reads = 988  
Discordant mates = 0

— translocation — deletion  
— duplication — inversion

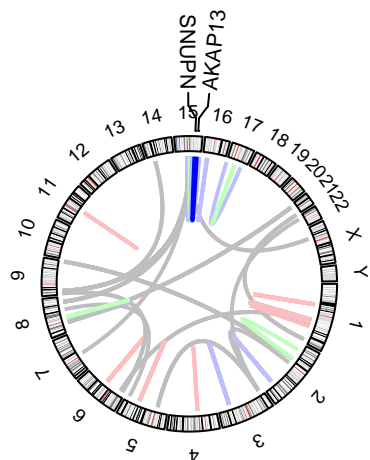
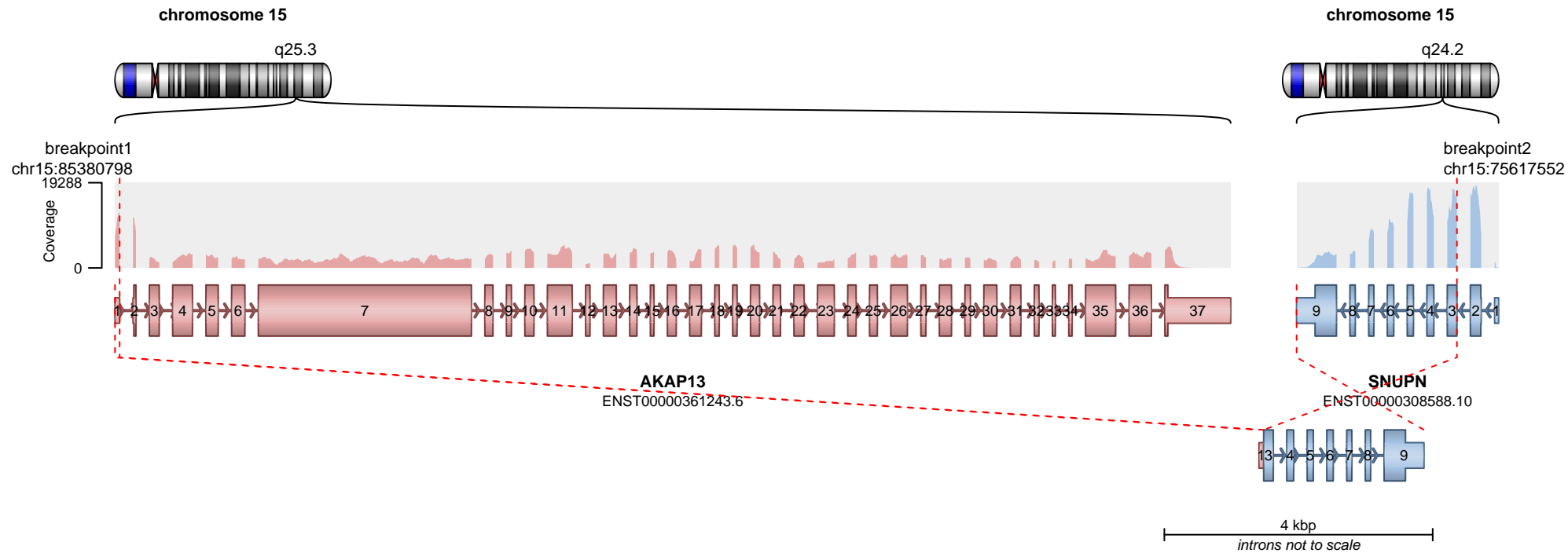

**RETAINED PROTEIN DOMAINS**  
reading frame unclear

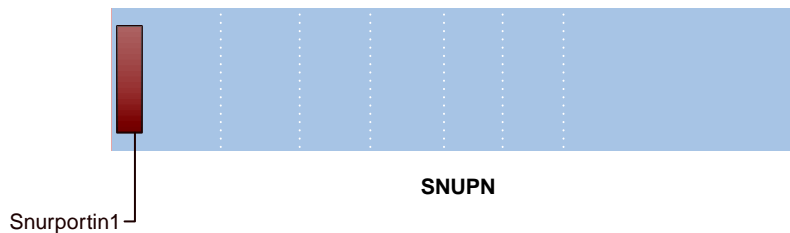

**SUPPORTING READ COUNT**

Split reads = 37  
Discordant mates = 0

— translocation — deletion  
— duplication — inversion

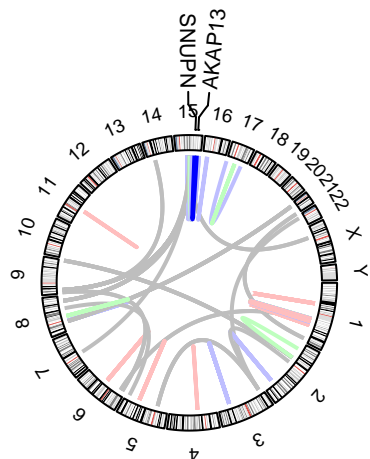
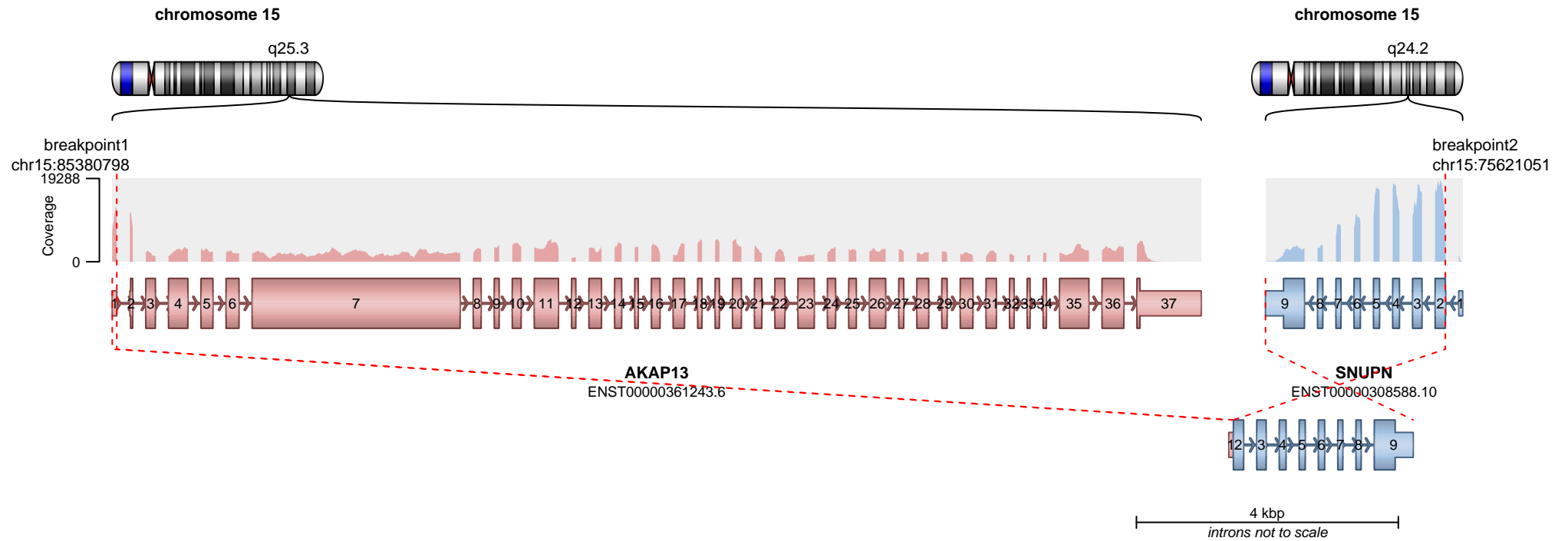

**RETAINED PROTEIN DOMAINS**  
reading frame unclear

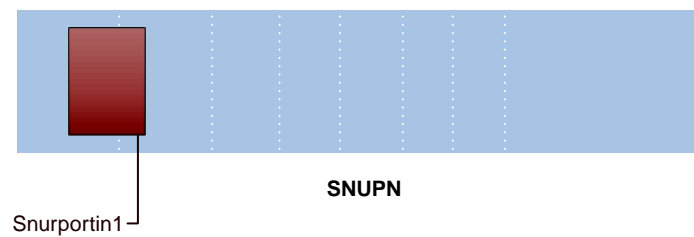

**SUPPORTING READ COUNT**

Split reads = 24  
Discordant mates = 0

— translocation — deletion  
— duplication — inversion

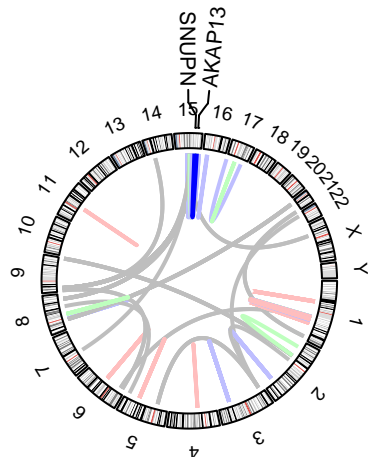
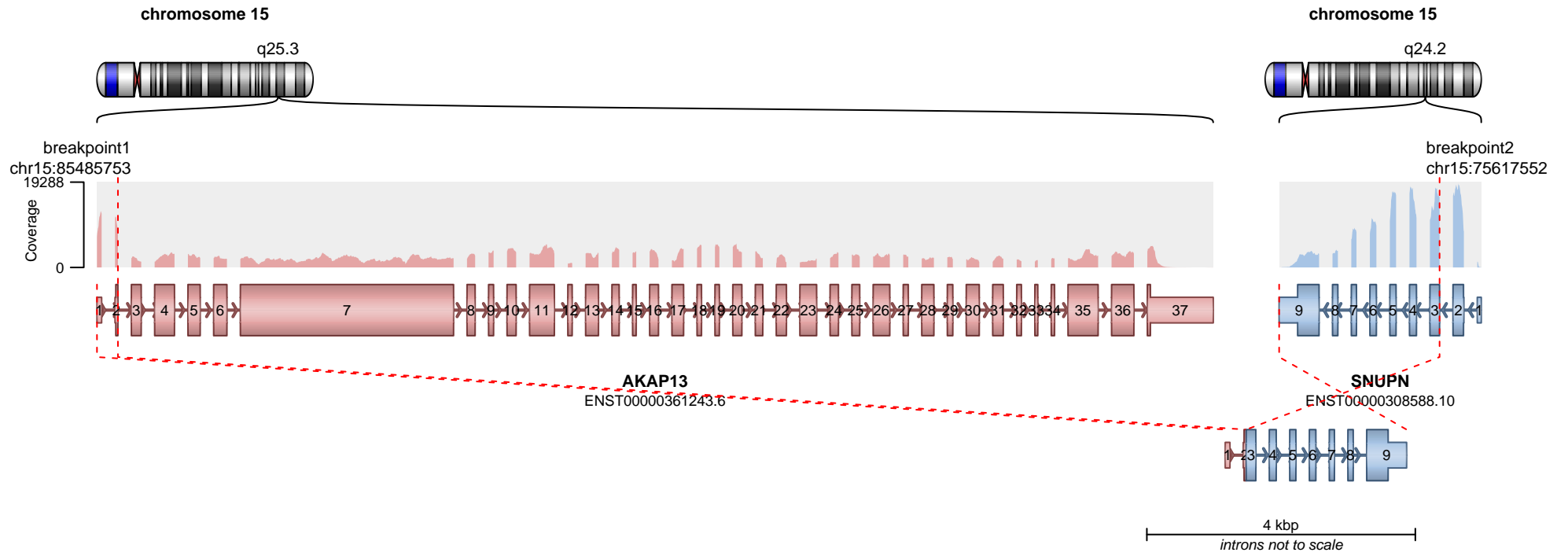

**RETAINED PROTEIN DOMAINS**  
reading frame unclear

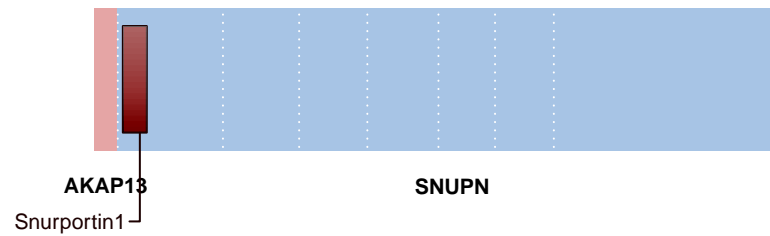

**SUPPORTING READ COUNT**

Split reads = 19  
Discordant mates = 0

— translocation — deletion  
— duplication — inversion

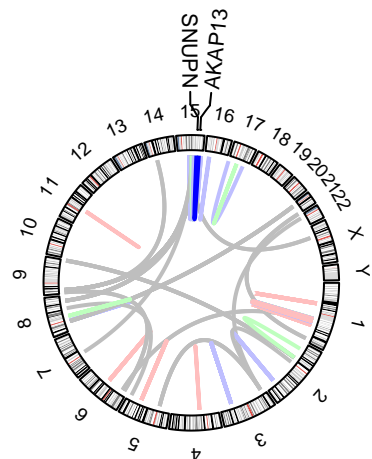
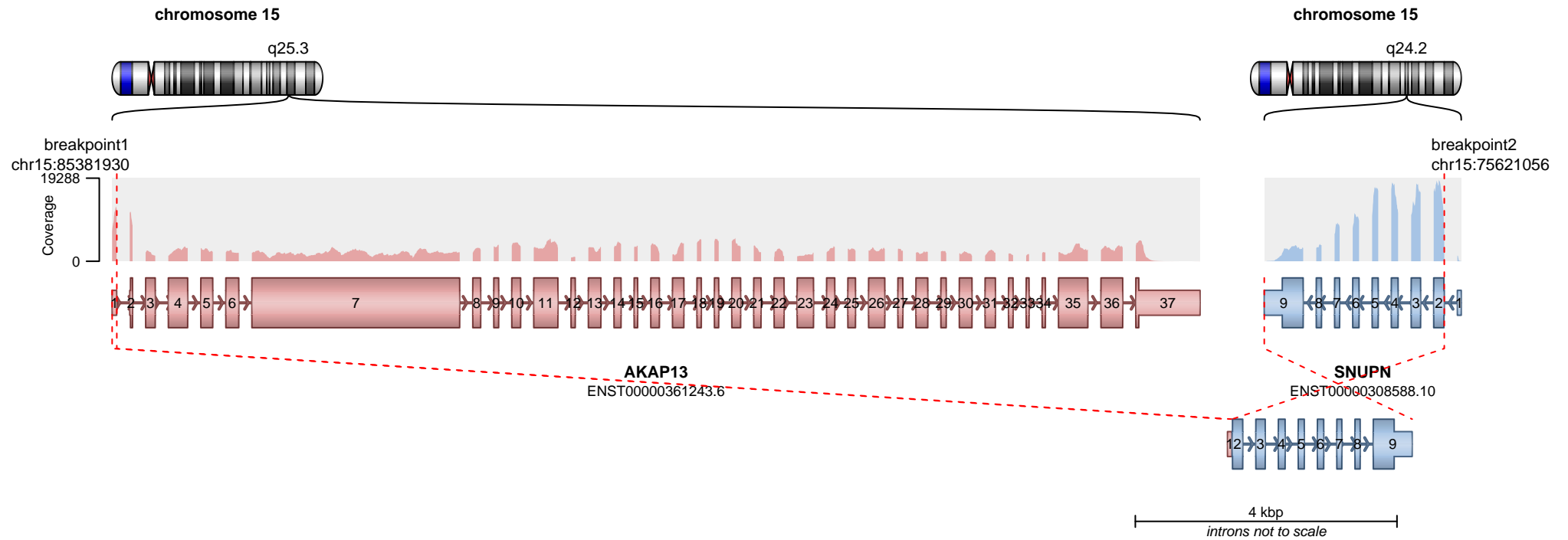

**RETAINED PROTEIN DOMAINS**  
reading frame unclear

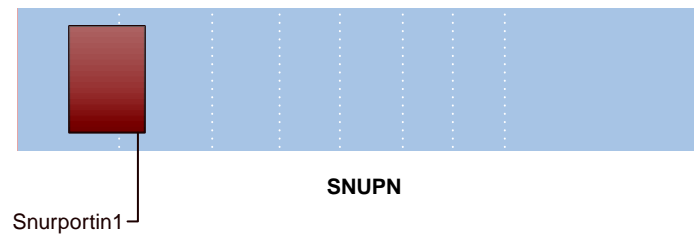

**SUPPORTING READ COUNT**

Split reads = 11  
Discordant mates = 0

— translocation — deletion  
— duplication — inversion

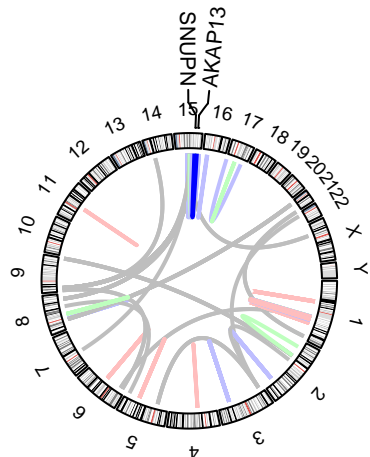
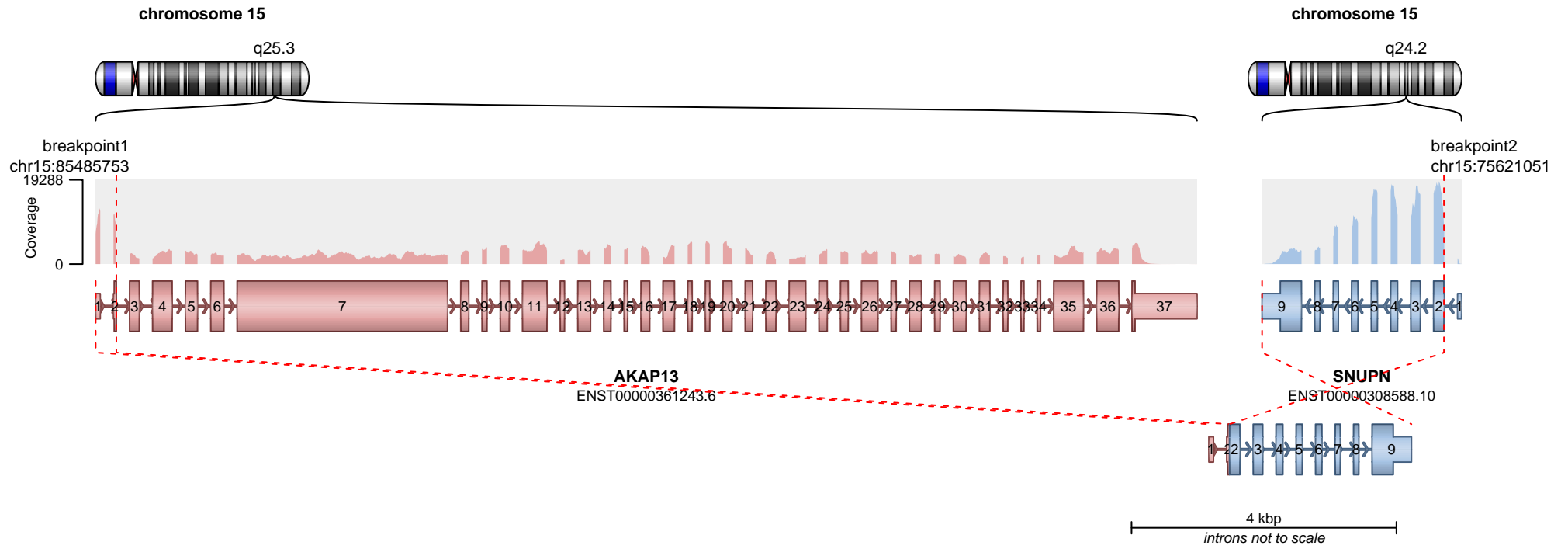

**RETAINED PROTEIN DOMAINS**  
reading frame unclear

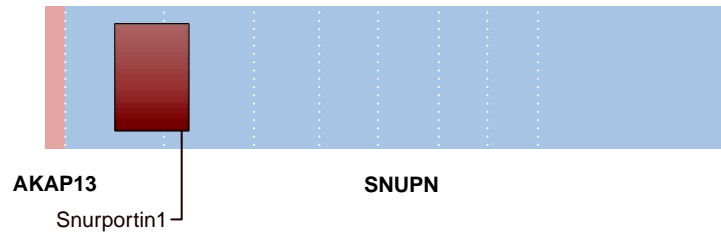

**SUPPORTING READ COUNT**

Split reads = 7  
Discordant mates = 0

- translocation
- duplication
- deletion
- inversion

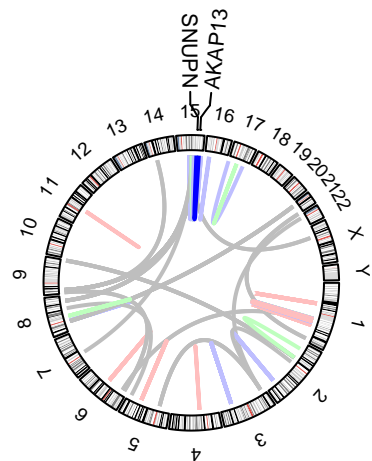
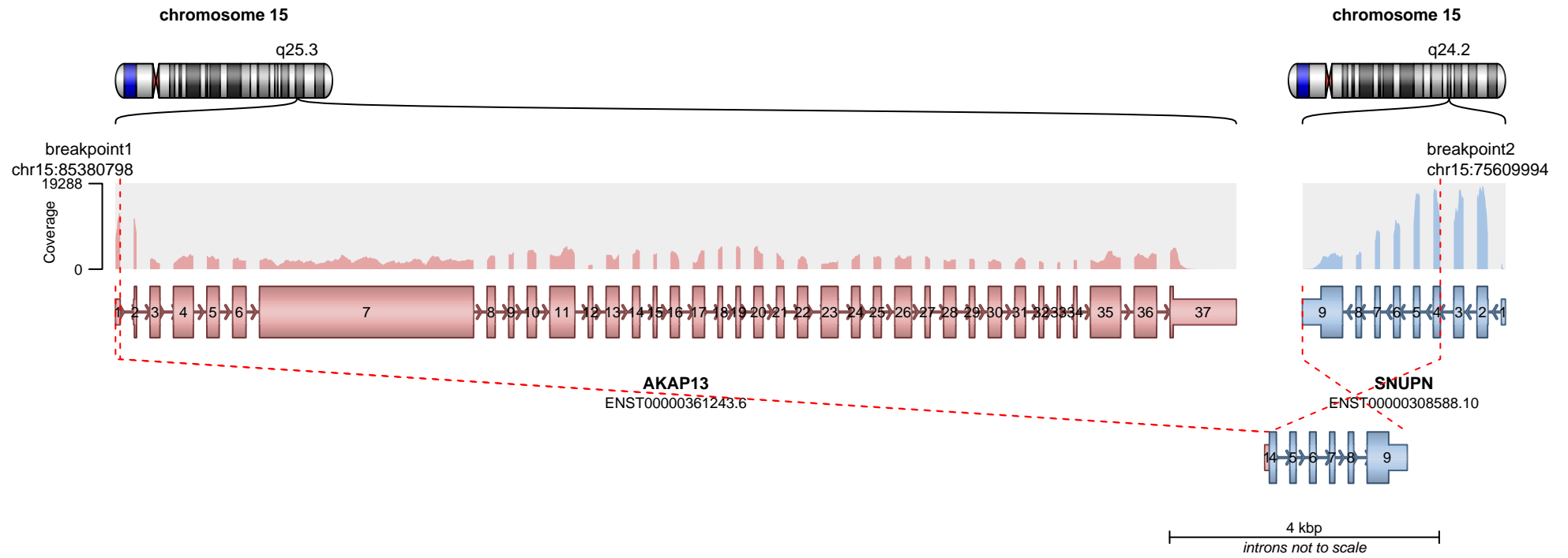

— translocation — deletion  
— duplication — inversion

No protein domains retained in fusion.

**SUPPORTING READ COUNT**

Split reads = 1  
Discordant mates = 0

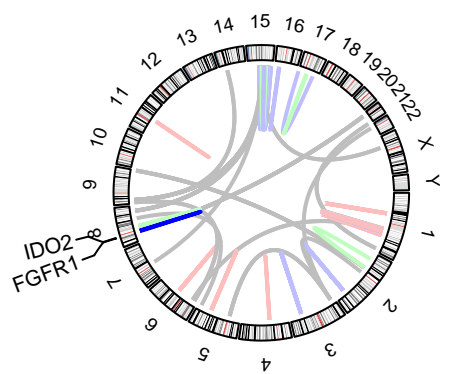
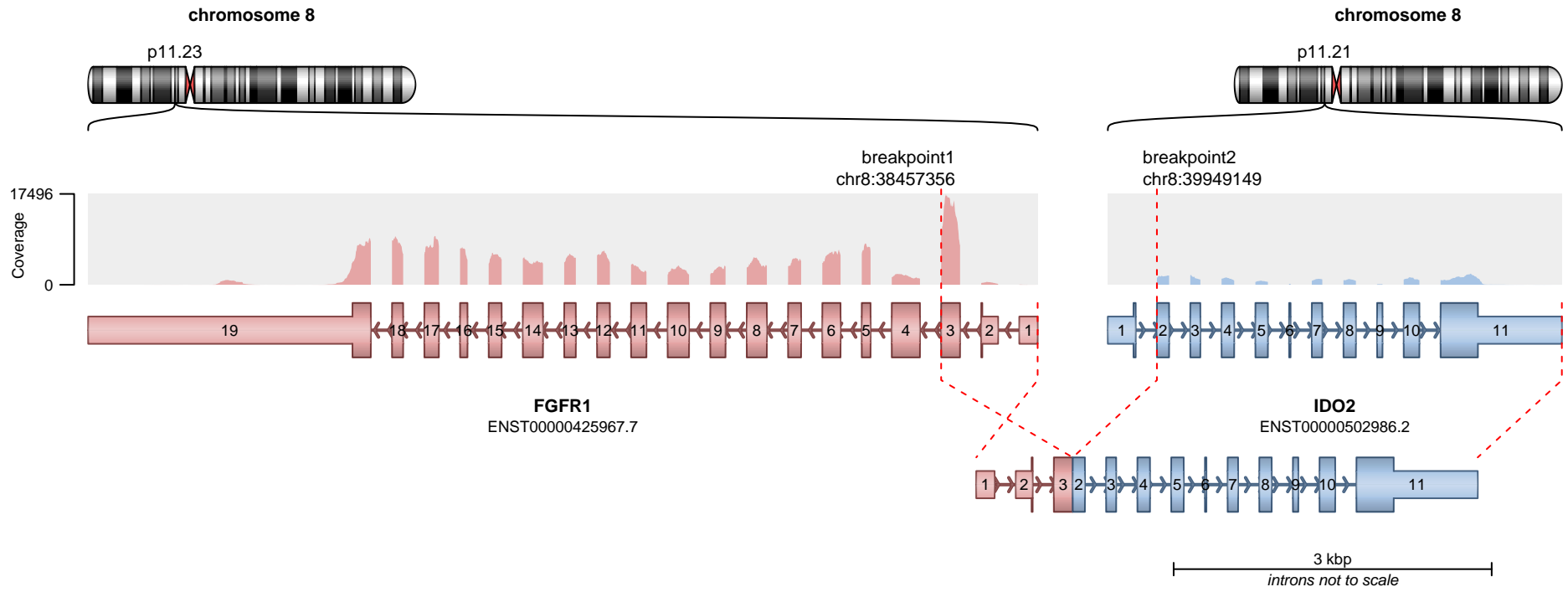

**RETAINED PROTEIN DOMAINS**  
reading frame unclear

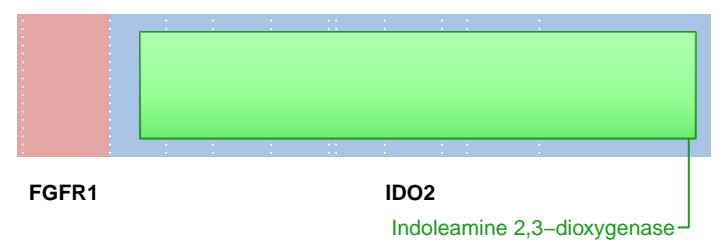

**SUPPORTING READ COUNT**

Split reads = 737  
Discordant mates = 4

- translocation
- duplication
- deletion
- inversion

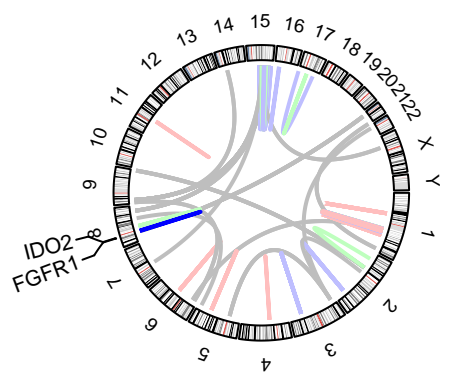
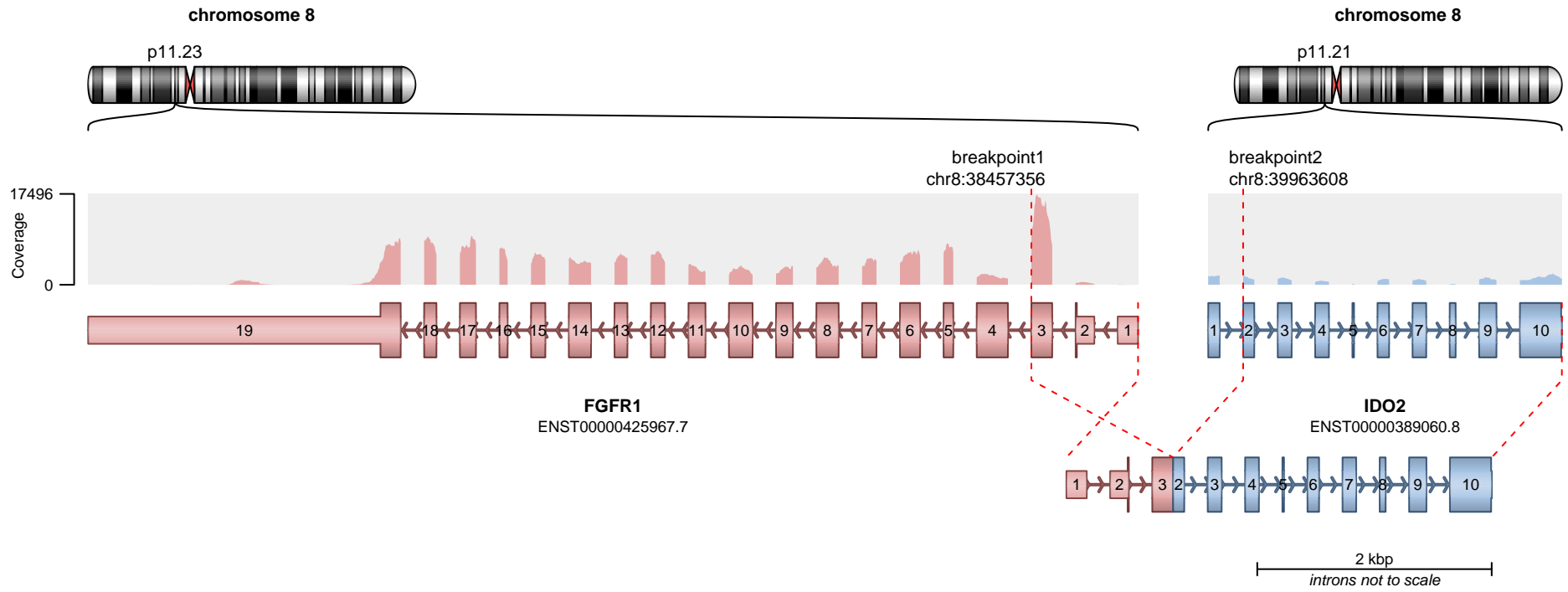

**RETAINED PROTEIN DOMAINS**  
reading frame unclear

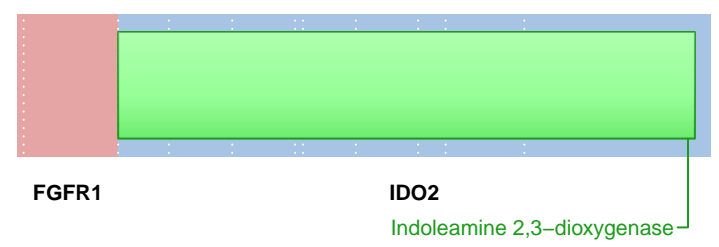

**SUPPORTING READ COUNT**

Split reads = 169  
Discordant mates = 0

- translocation
- duplication
- deletion
- inversion

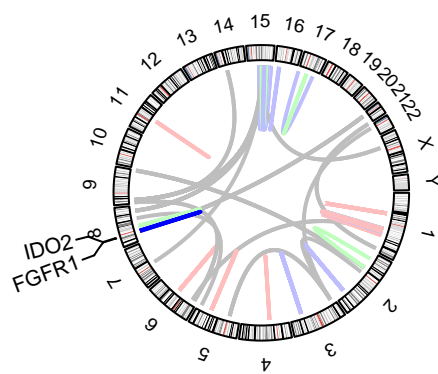
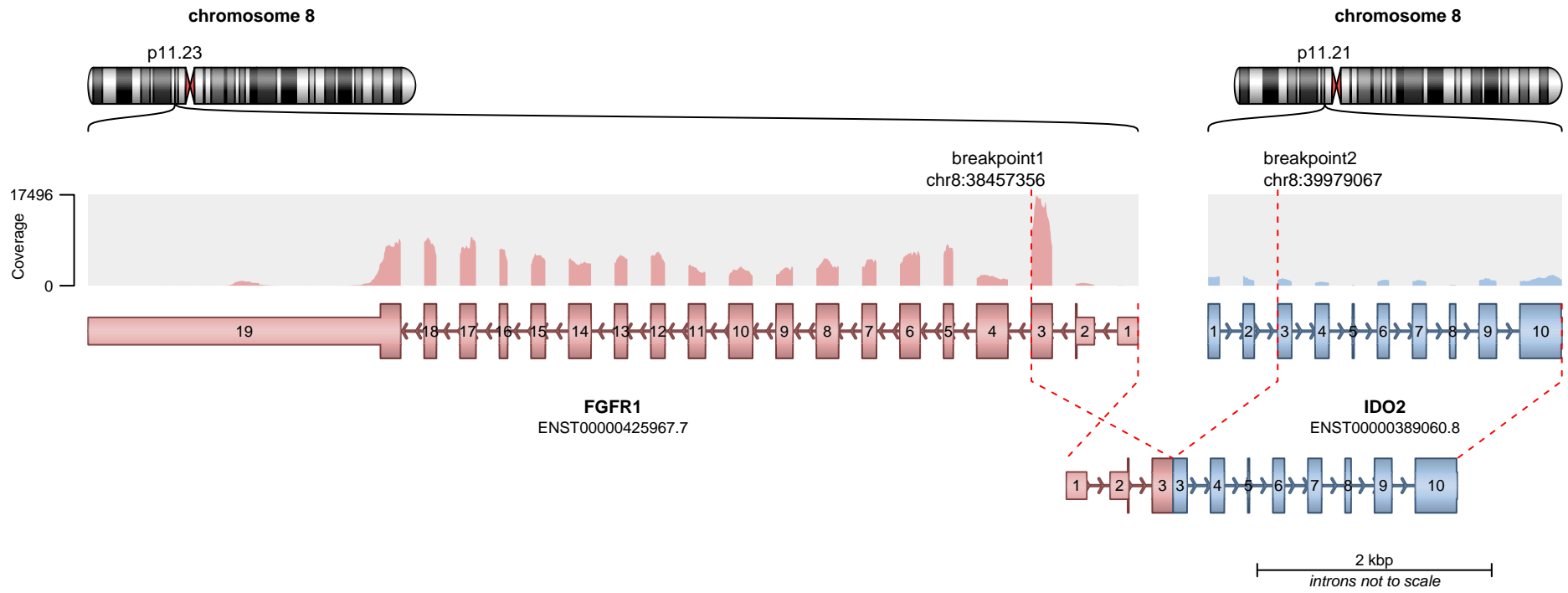

**RETAINED PROTEIN DOMAINS**  
reading frame unclear

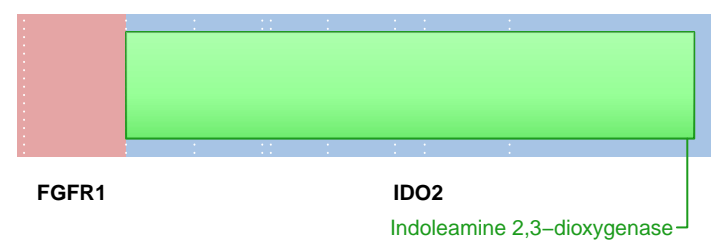

**SUPPORTING READ COUNT**

Split reads = 5  
Discordant mates = 0

- translocation
- duplication
- deletion
- inversion

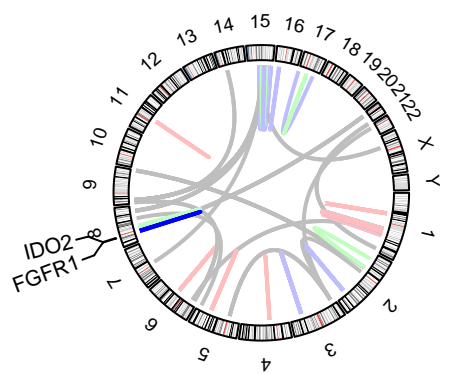
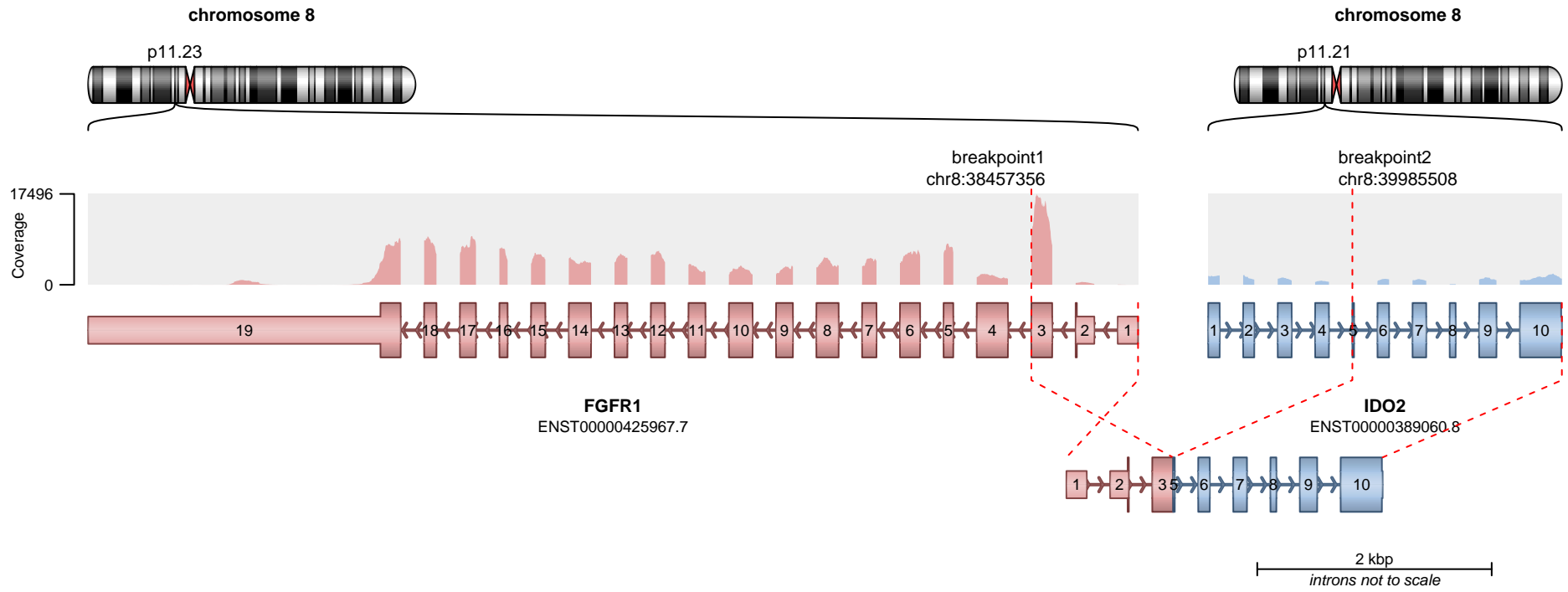

**RETAINED PROTEIN DOMAINS**  
reading frame unclear

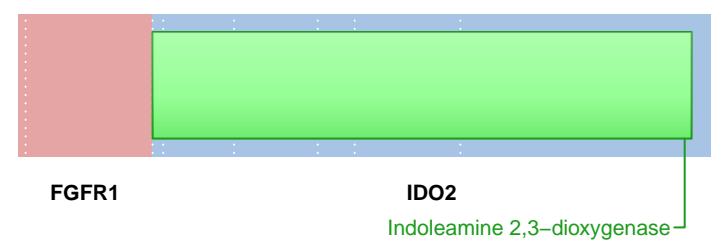

**SUPPORTING READ COUNT**

Split reads = 4  
Discordant mates = 0

— translocation    — deletion  
— duplication    — inversion

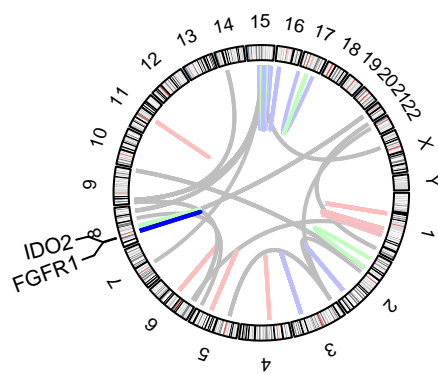
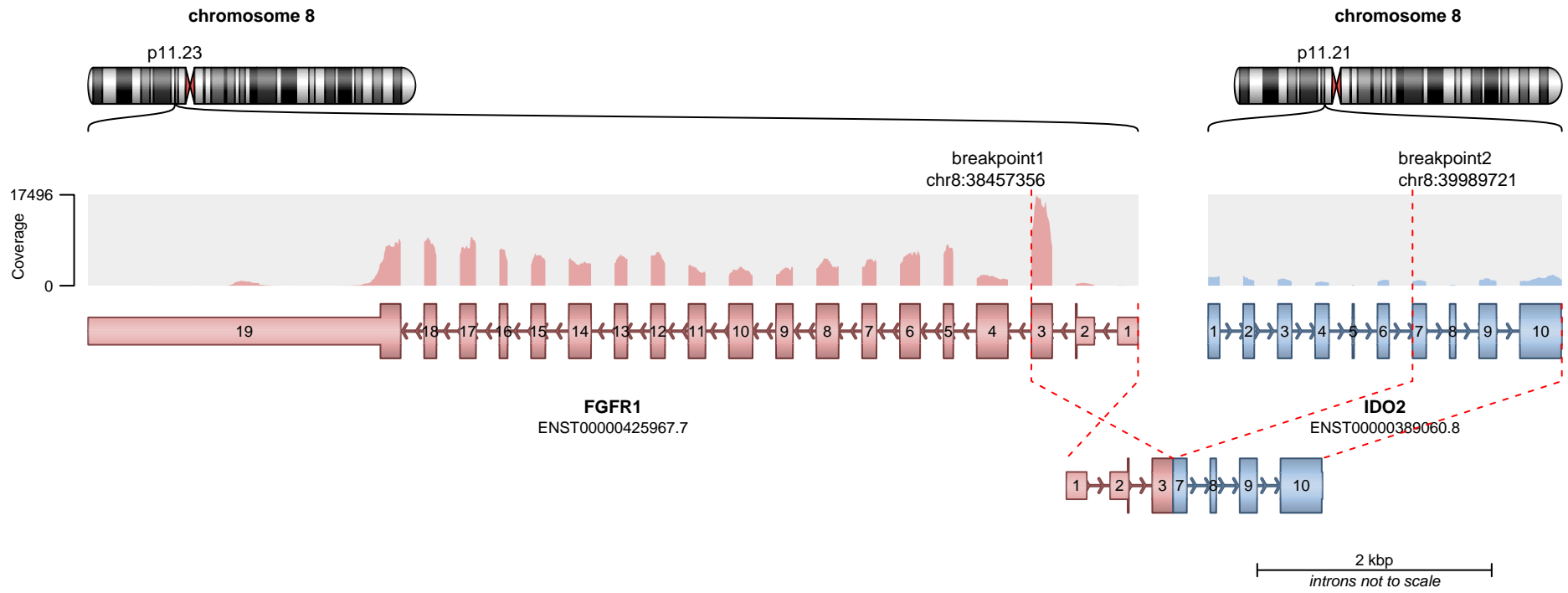

**RETAINED PROTEIN DOMAINS**  
reading frame unclear

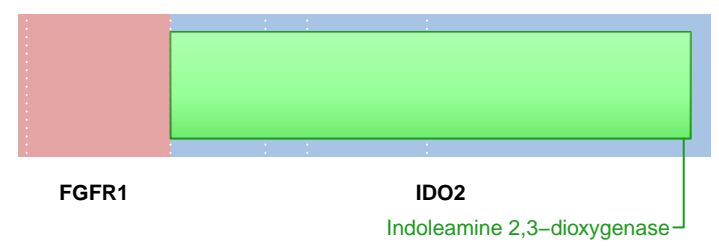

**SUPPORTING READ COUNT**

Split reads = 1  
Discordant mates = 0

- translocation
- duplication
- deletion
- inversion

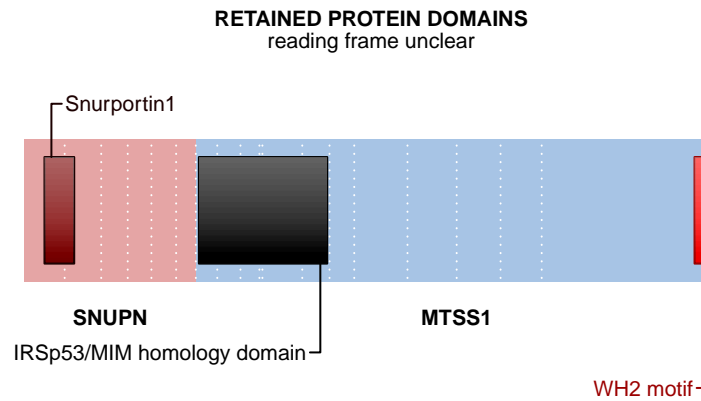
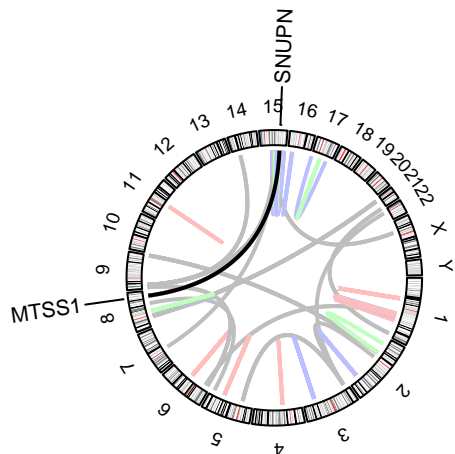
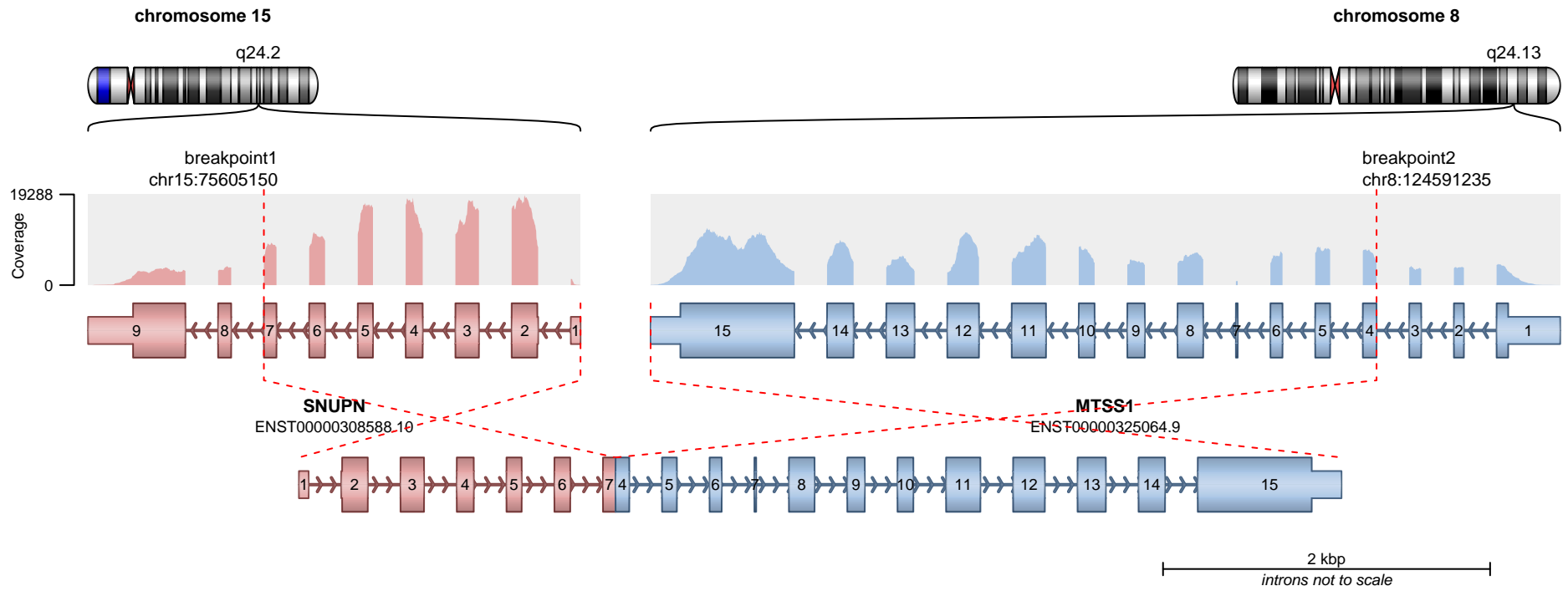

**SUPPORTING READ COUNT**

Split reads = 621  
Discordant mates = 8

- translocation
- duplication
- deletion
- inversion

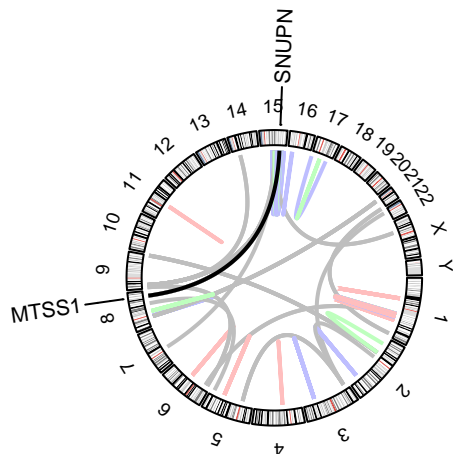
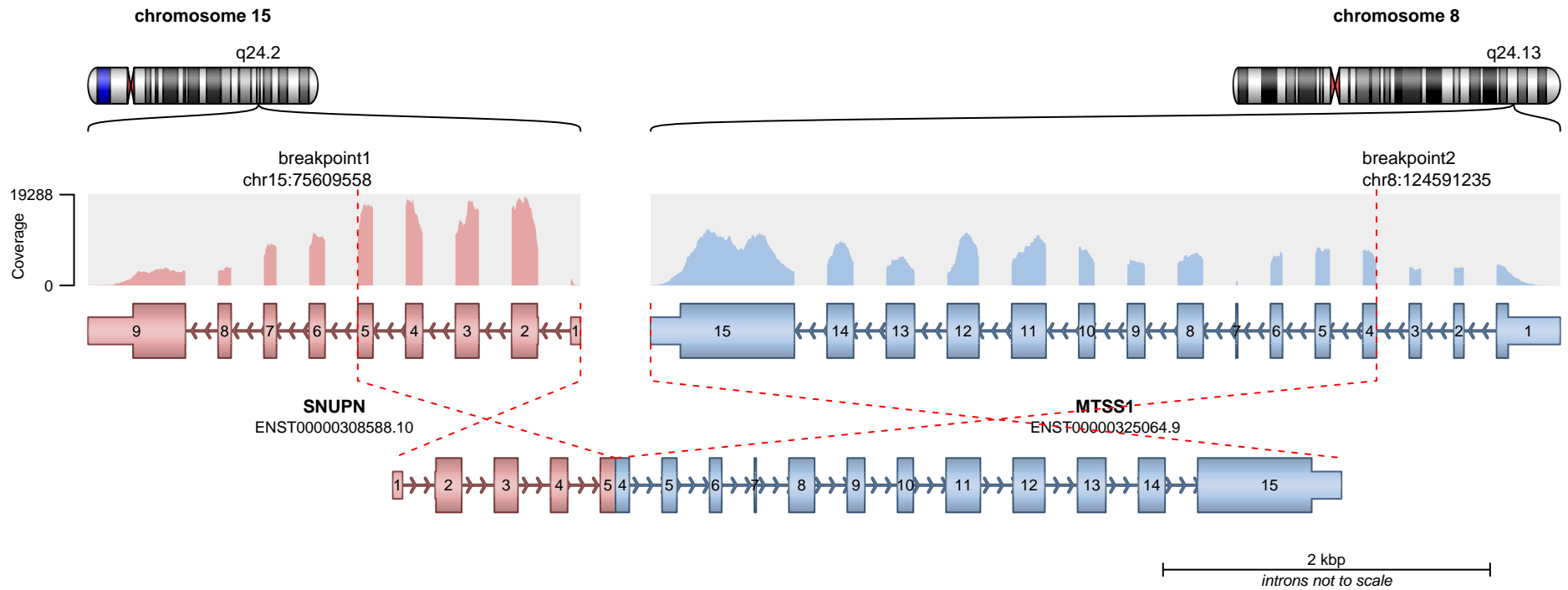

**RETAINED PROTEIN DOMAINS**  
reading frame unclear

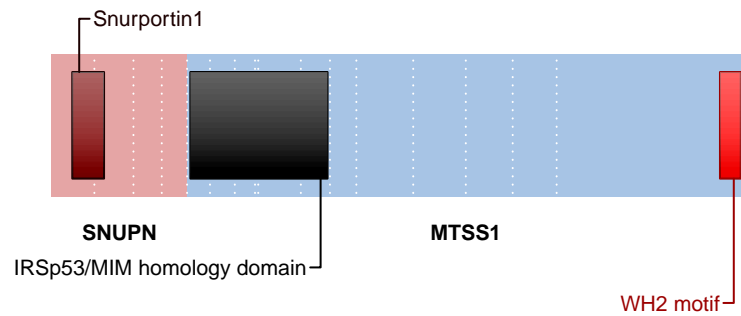

**SUPPORTING READ COUNT**

Split reads = 62  
Discordant mates = 3

- translocation
- duplication
- deletion
- inversion

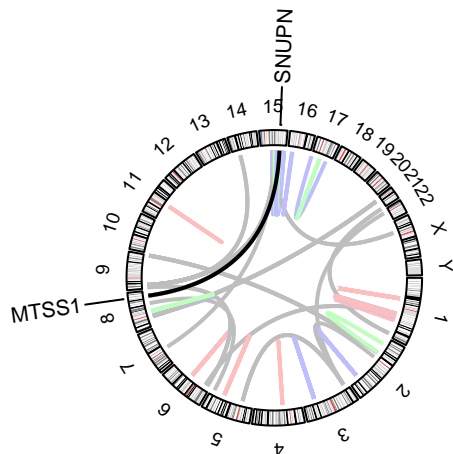
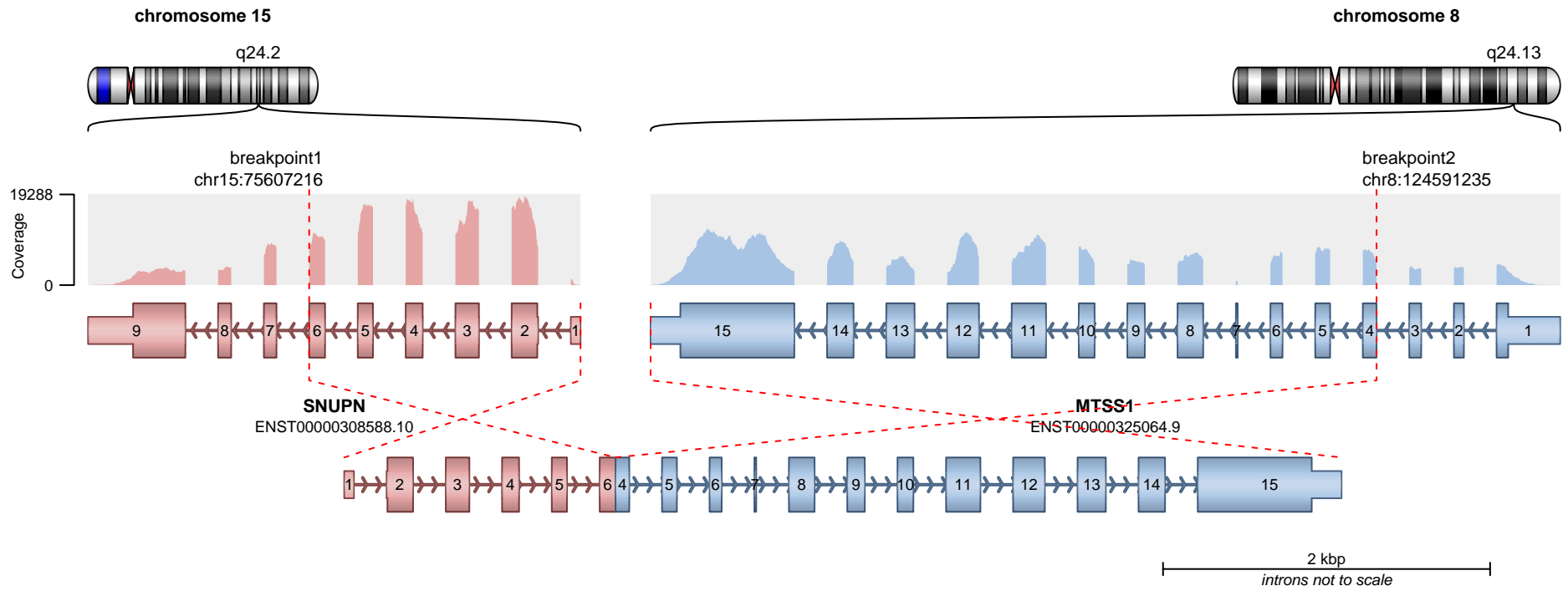

**RETAINED PROTEIN DOMAINS**  
reading frame unclear

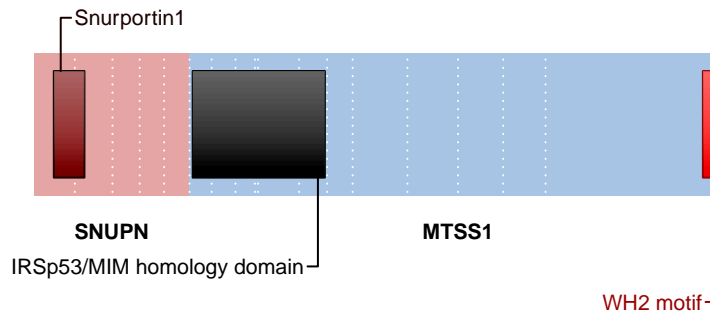

**SUPPORTING READ COUNT**

Split reads = 1  
Discordant mates = 6

— translocation    — deletion  
— duplication    — inversion

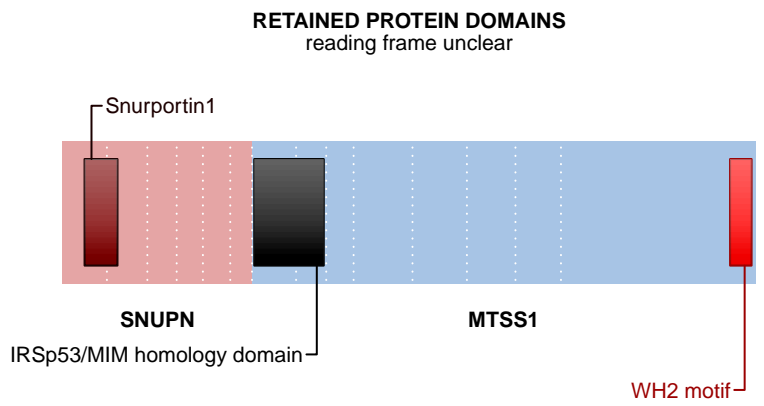
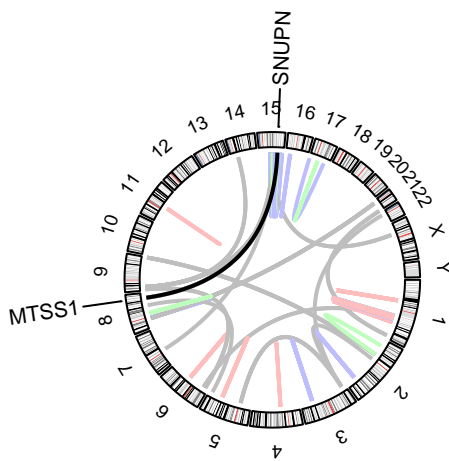
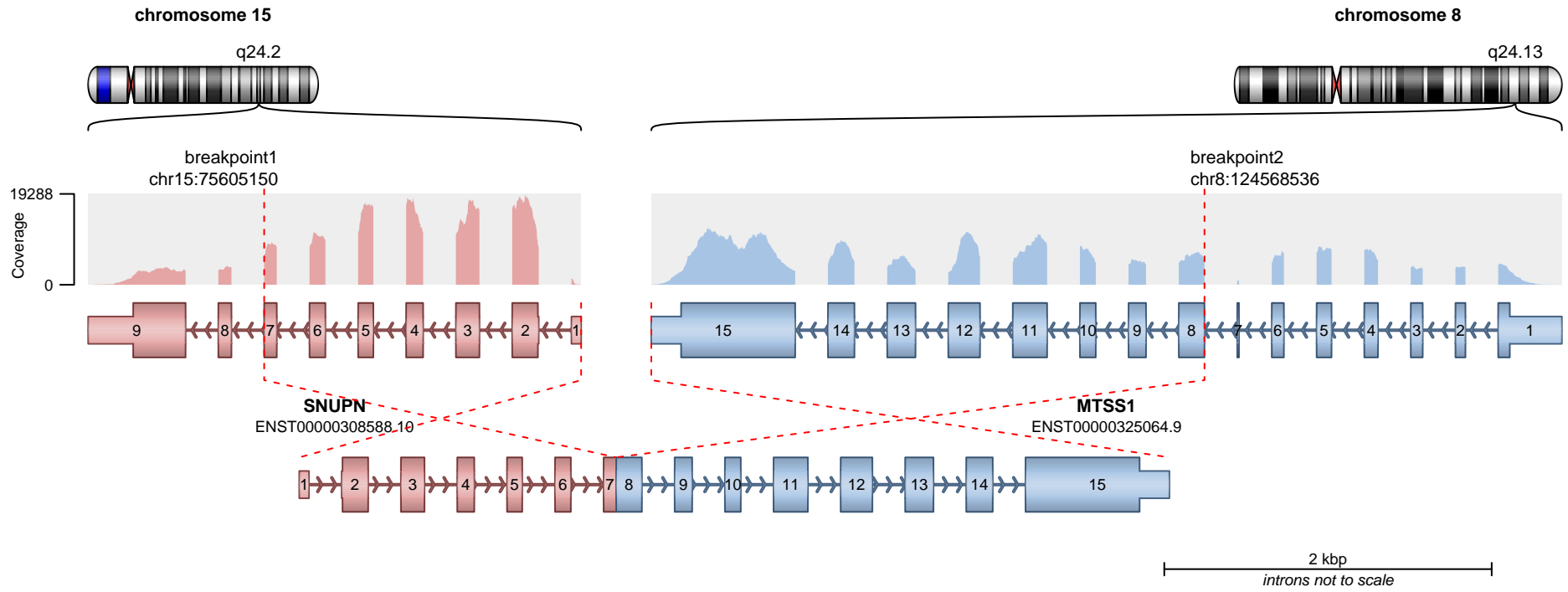

**SUPPORTING READ COUNT**

Split reads = 1  
Discordant mates = 0

— translocation    — deletion  
— duplication    — inversion

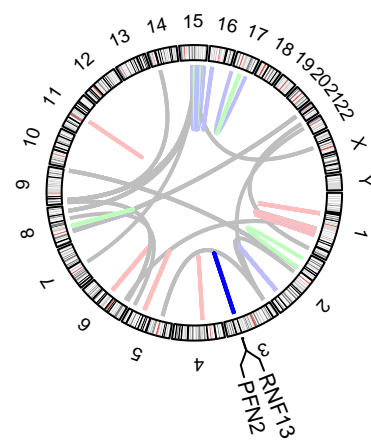
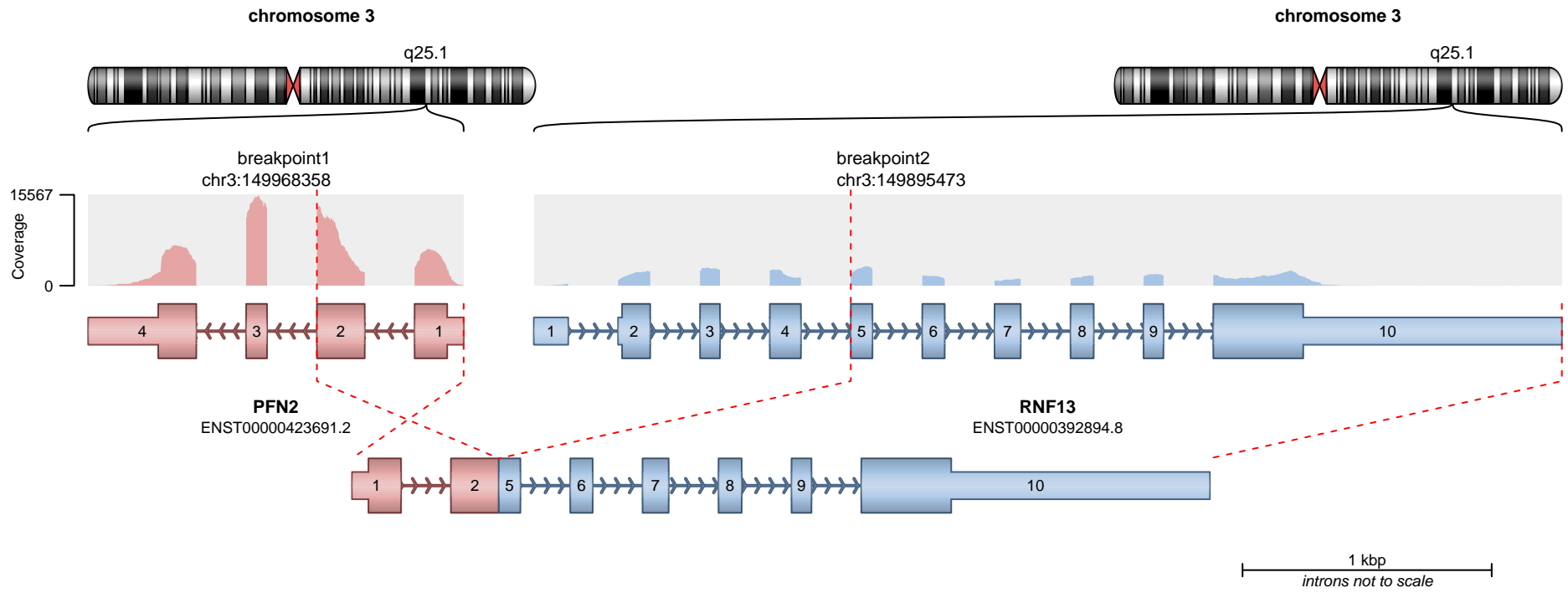

**RETAINED PROTEIN DOMAINS**  
reading frame unclear

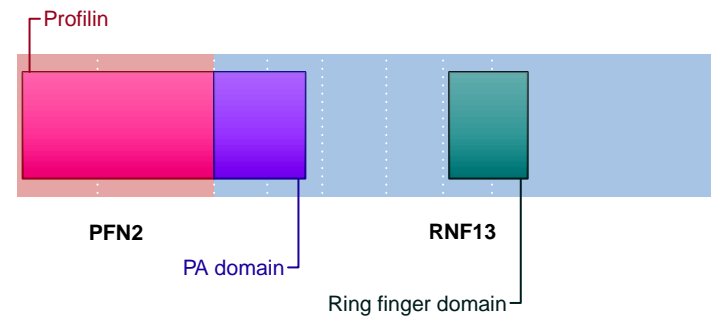

**SUPPORTING READ COUNT**

Split reads = 406  
Discordant mates = 0

- translocation
- duplication
- deletion
- inversion

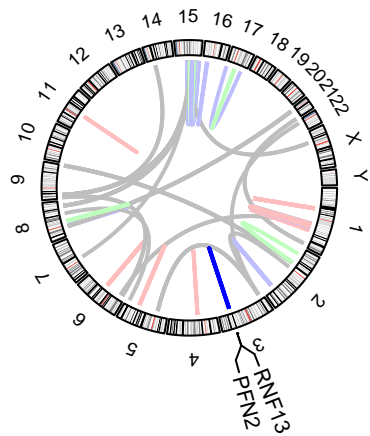
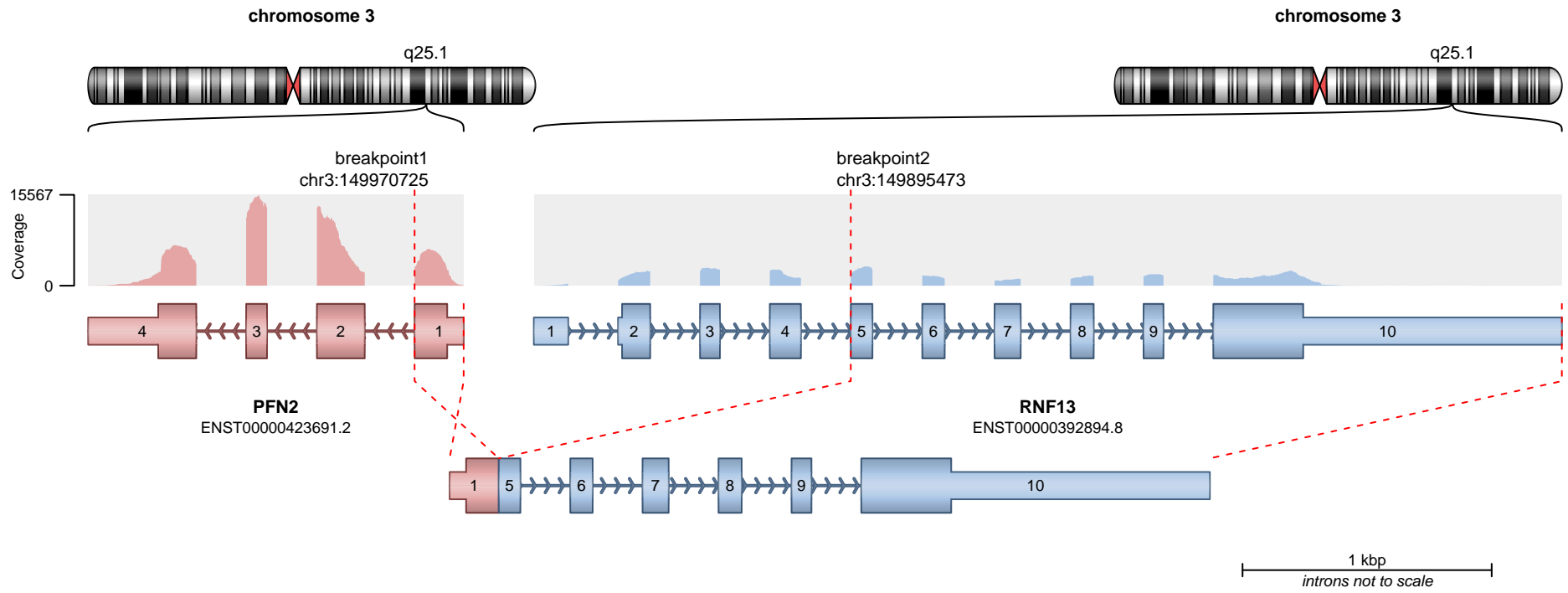

**RETAINED PROTEIN DOMAINS**  
reading frame unclear

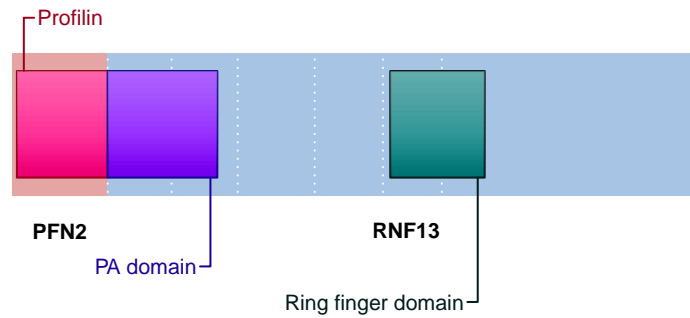

**SUPPORTING READ COUNT**

Split reads = 11  
Discordant mates = 0

- translocation
- duplication
- deletion
- inversion

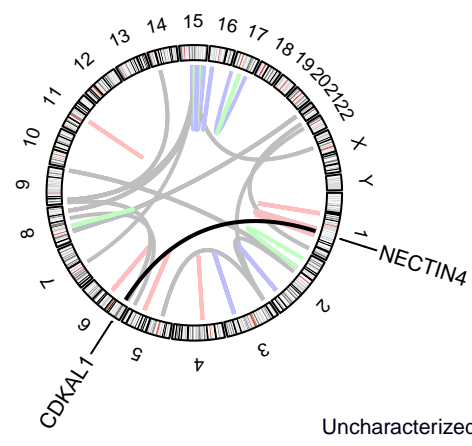
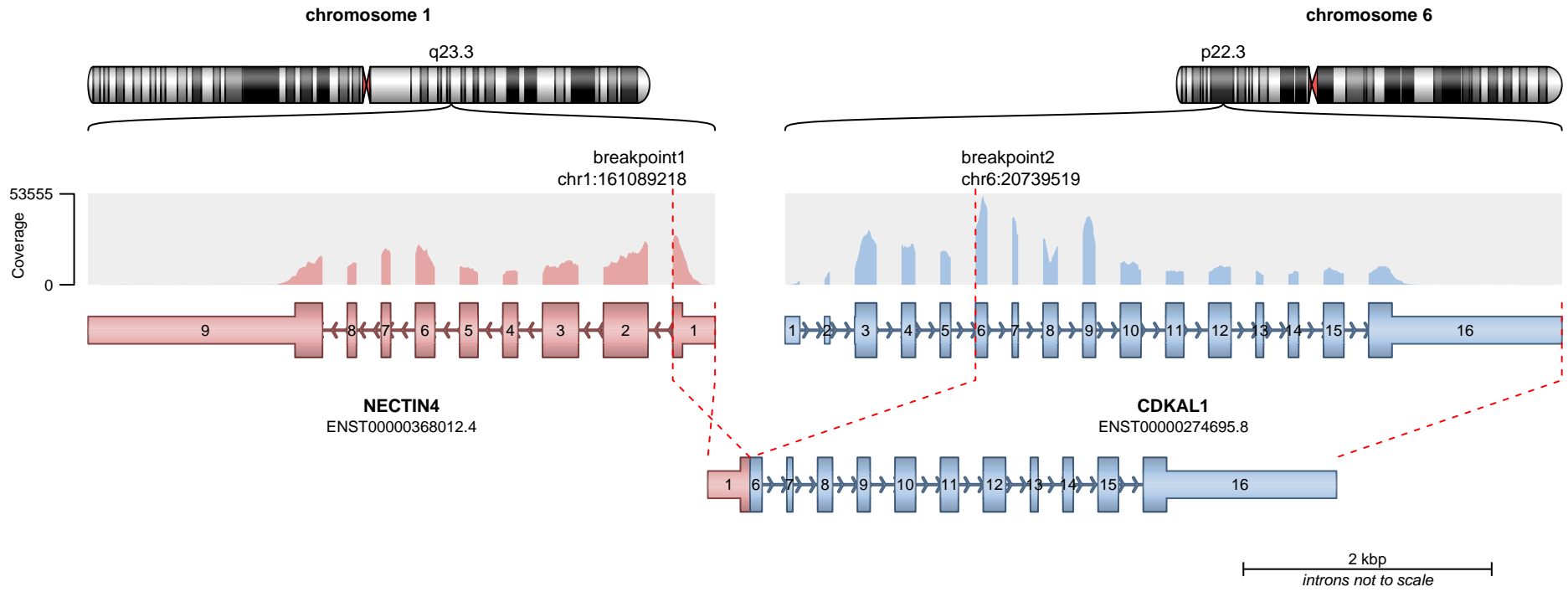

**RETAINED PROTEIN DOMAINS**  
reading frame unclear

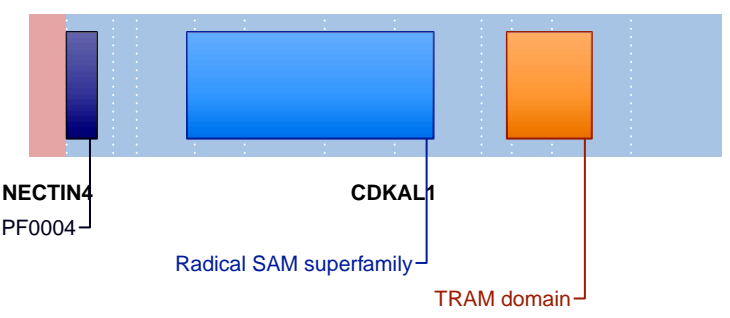

**SUPPORTING READ COUNT**

Split reads = 333  
Discordant mates = 2

- translocation
- duplication
- deletion
- inversion

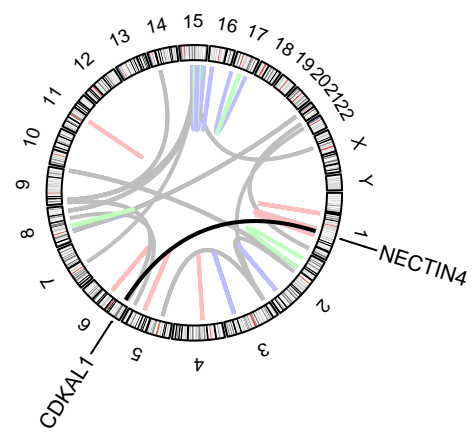
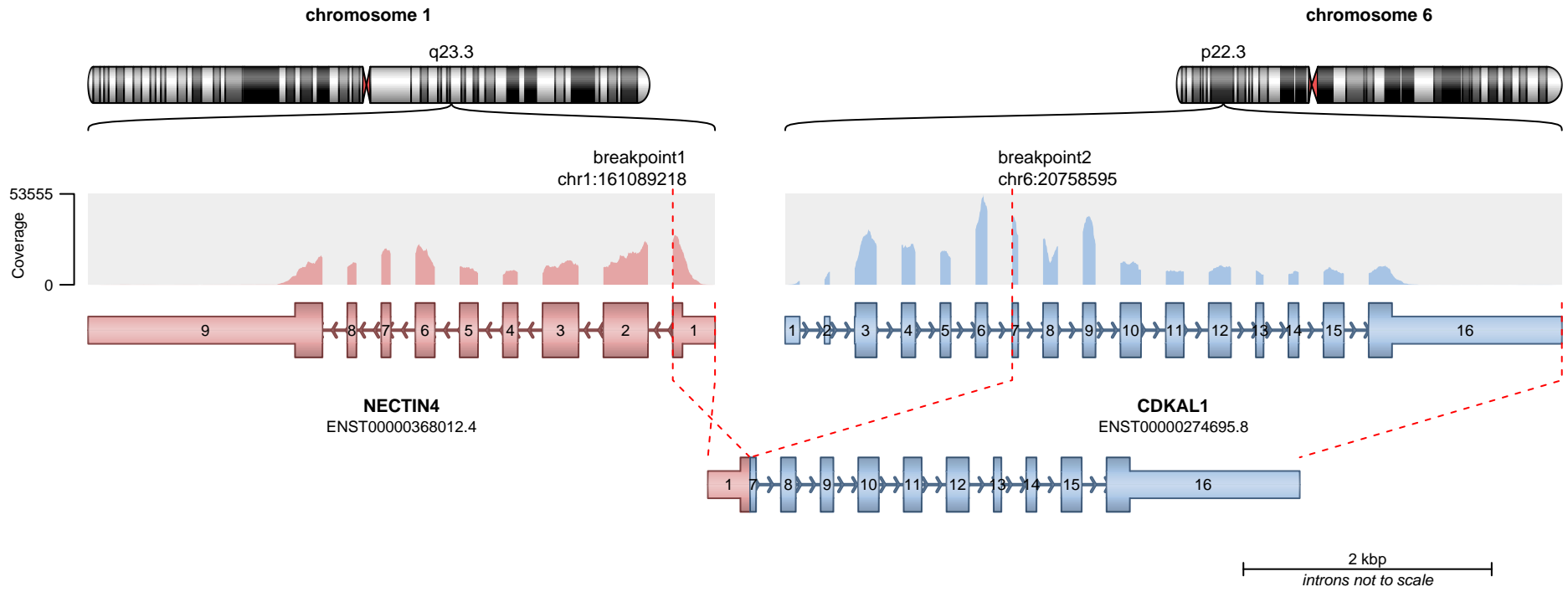

**RETAINED PROTEIN DOMAINS**  
reading frame unclear

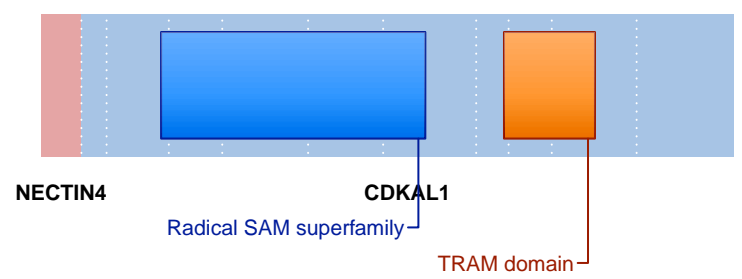

**SUPPORTING READ COUNT**

Split reads = 3  
Discordant mates = 0

- translocation
- duplication
- deletion
- inversion

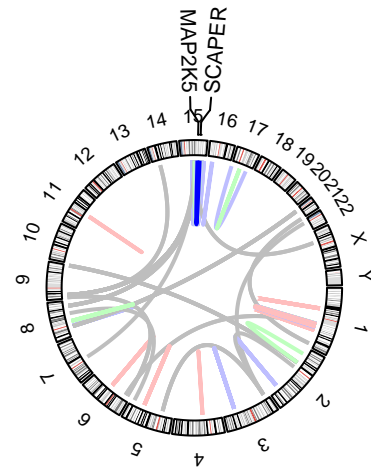
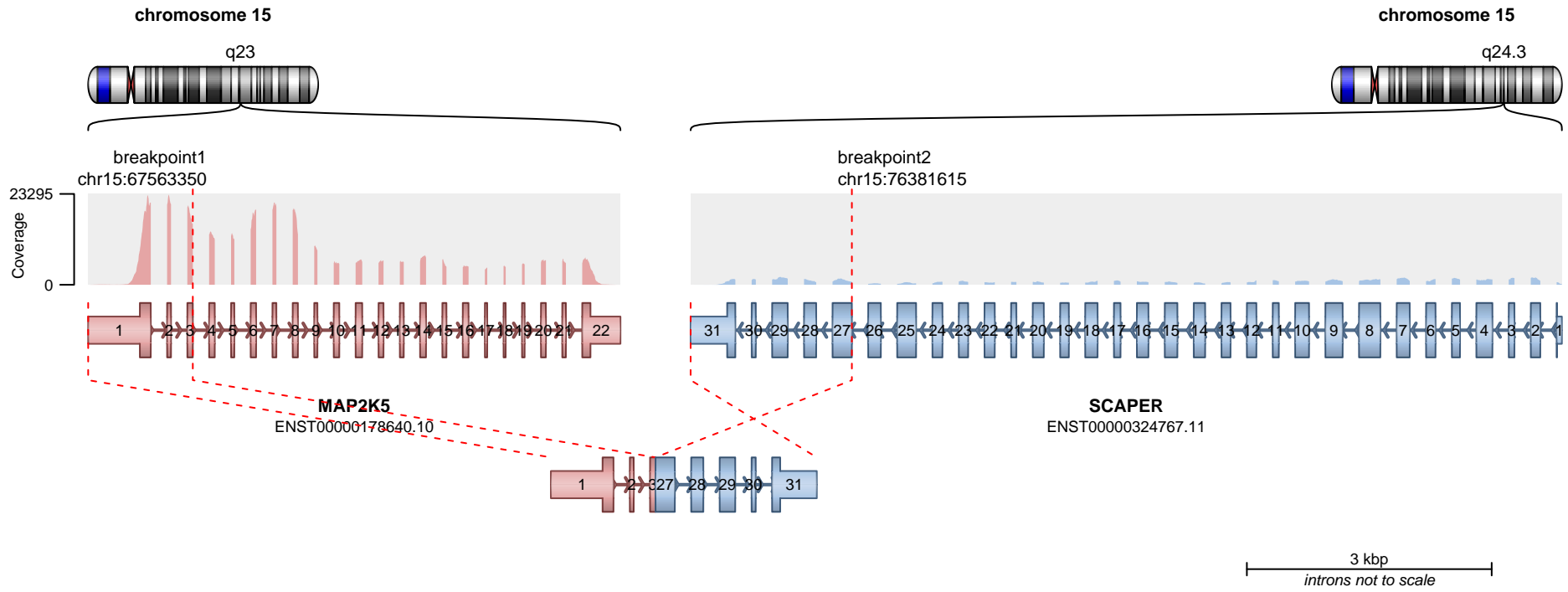

**RETAINED PROTEIN DOMAINS**  
reading frame unclear

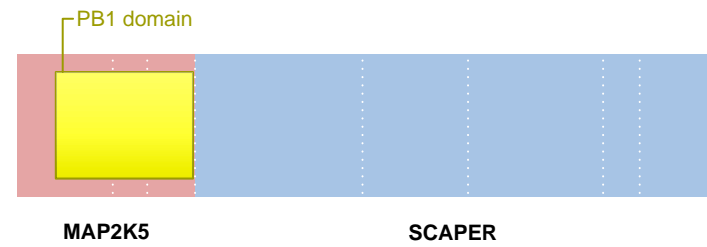

**SUPPORTING READ COUNT**

Split reads = 303  
Discordant mates = 11

- translocation
- duplication
- deletion
- inversion

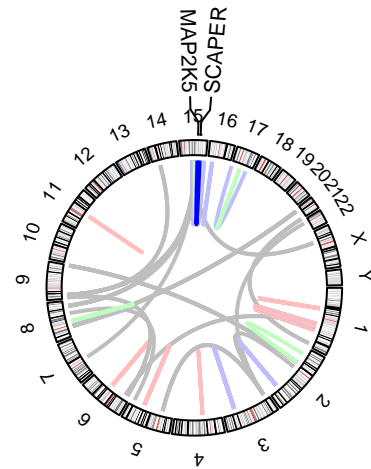
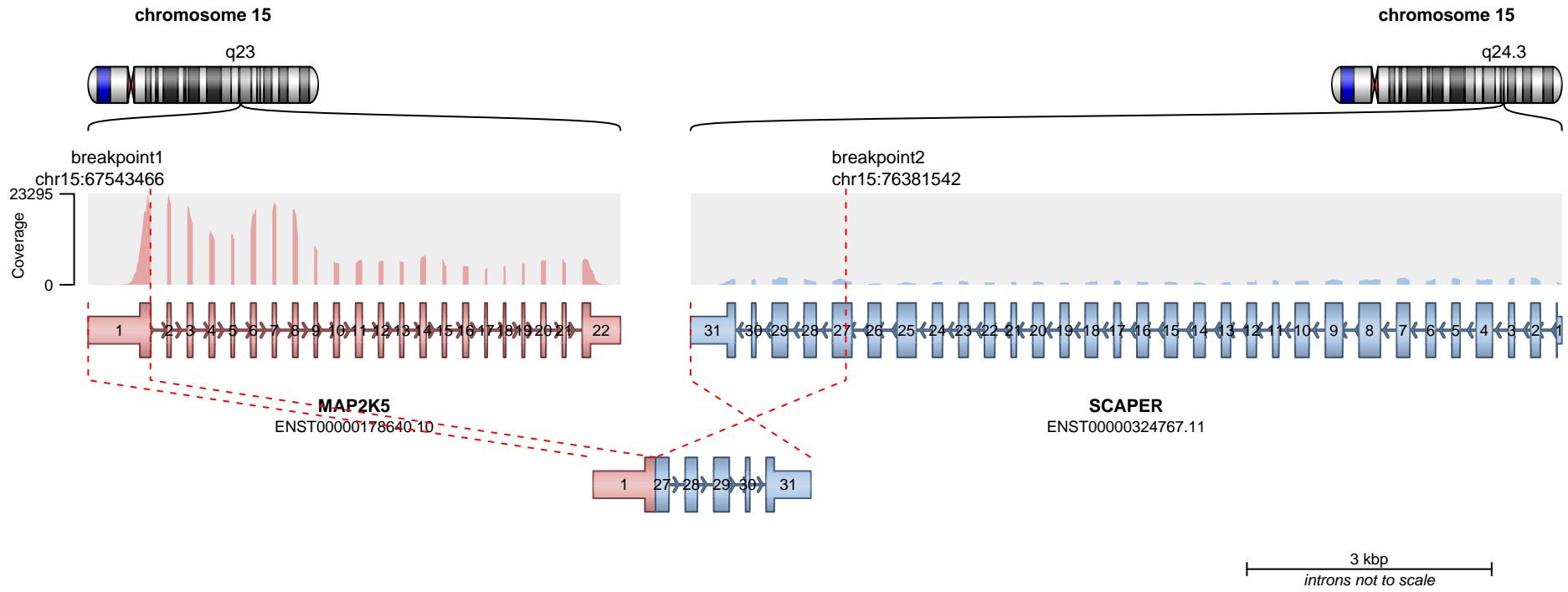

**RETAINED PROTEIN DOMAINS**  
reading frame unclear

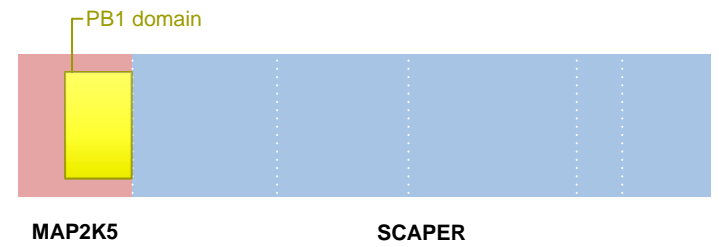

**SUPPORTING READ COUNT**

Split reads = 5  
Discordant mates = 0

— translocation — deletion  
— duplication — inversion

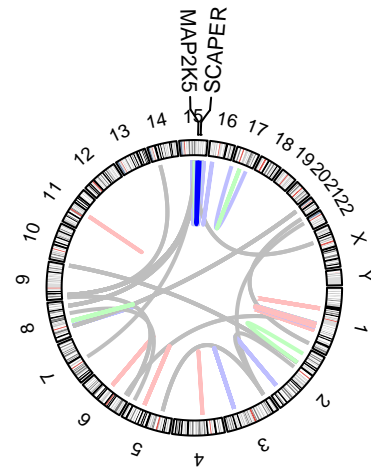
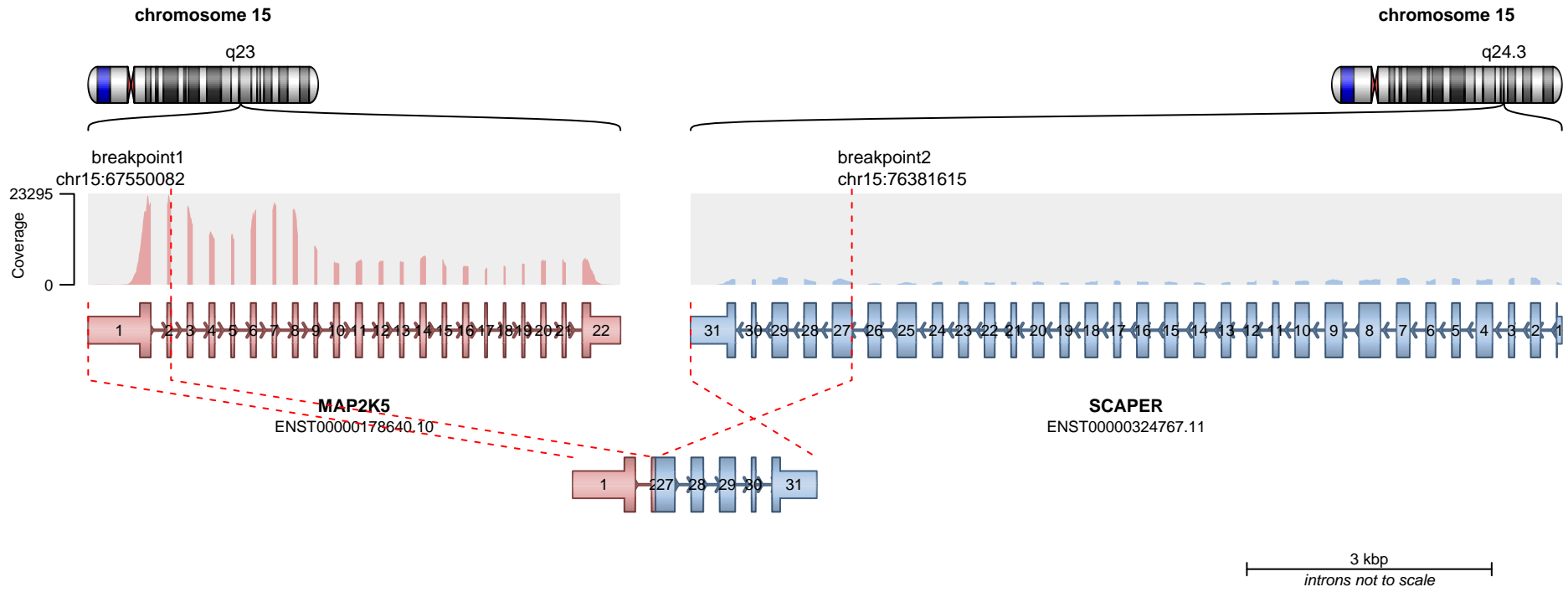

**RETAINED PROTEIN DOMAINS**  
reading frame unclear

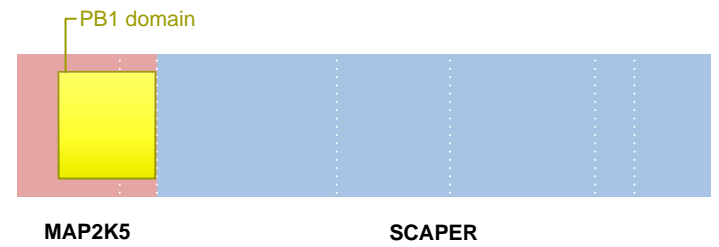

**SUPPORTING READ COUNT**

Split reads = 4  
Discordant mates = 4

- translocation
- duplication
- deletion
- inversion

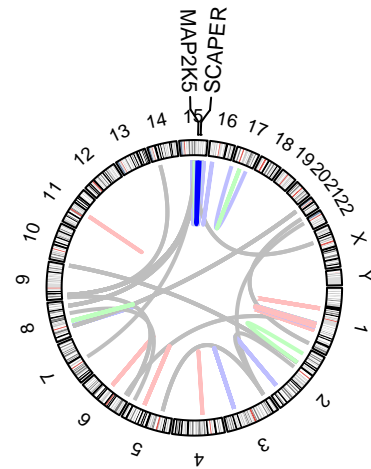
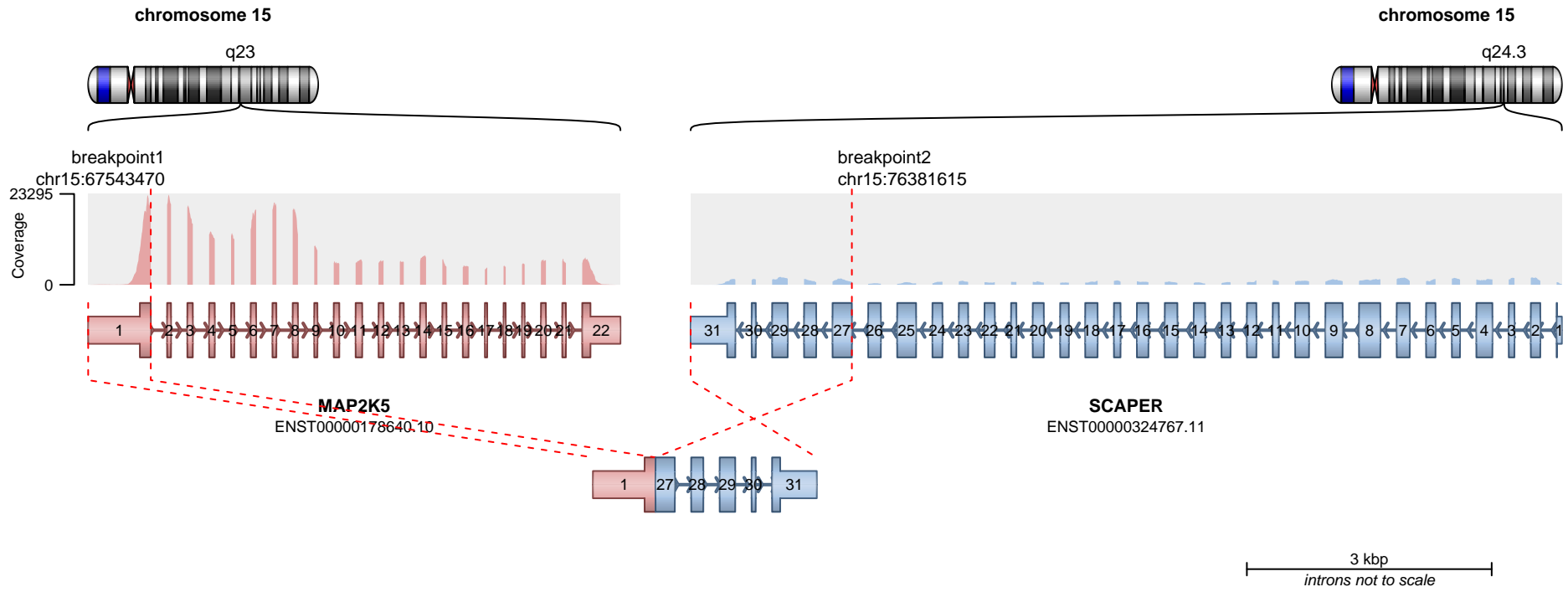

**RETAINED PROTEIN DOMAINS**  
reading frame unclear

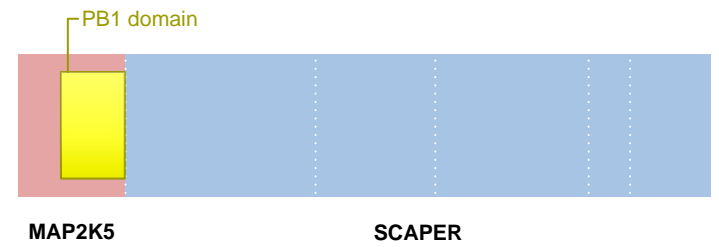

**SUPPORTING READ COUNT**

Split reads = 1  
Discordant mates = 1

— translocation — deletion  
— duplication — inversion

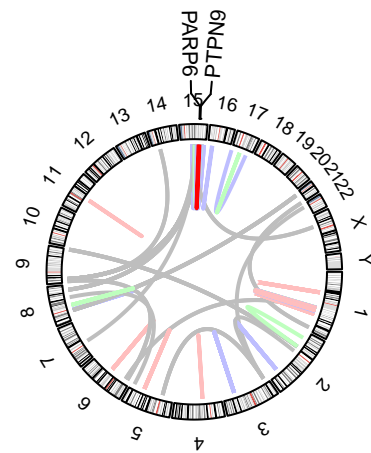
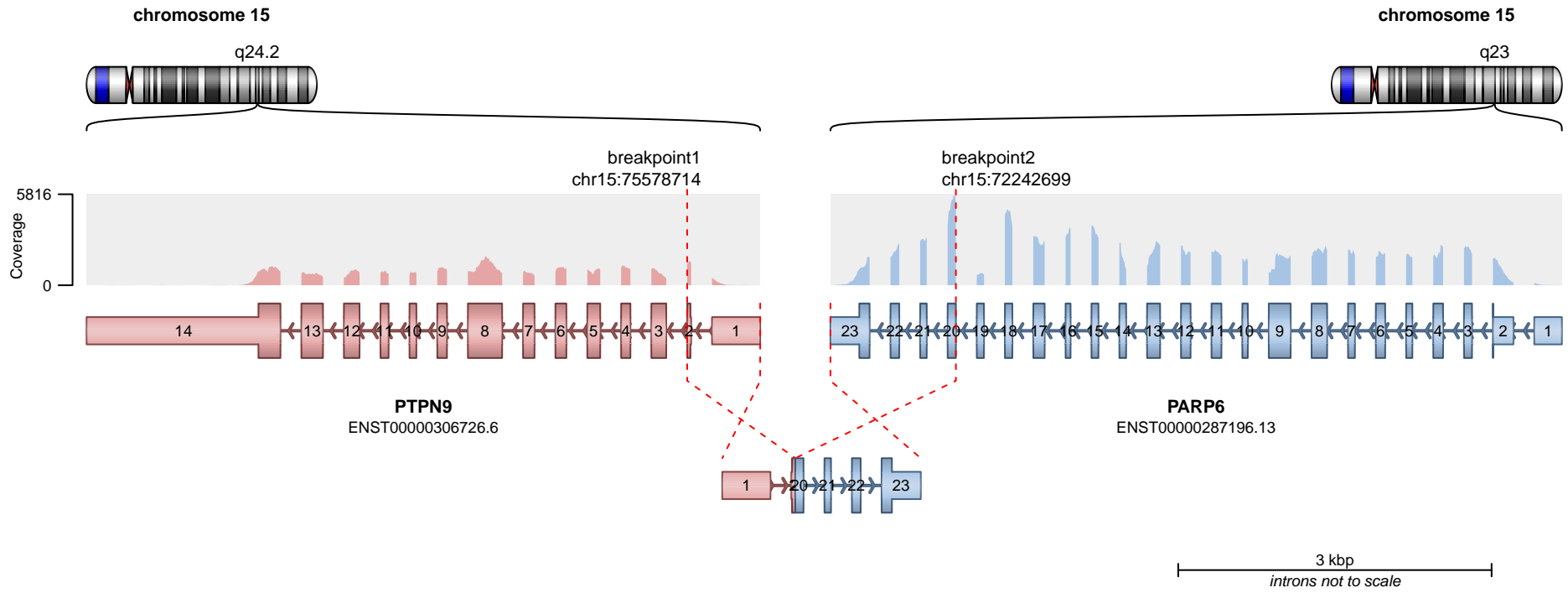

**RETAINED PROTEIN DOMAINS**  
reading frame unclear

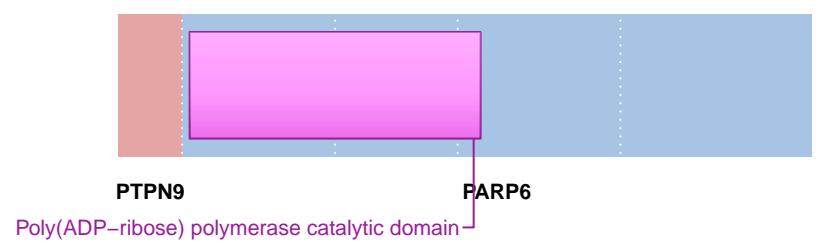

**SUPPORTING READ COUNT**

Split reads = 301  
Discordant mates = 0

- translocation
- duplication
- deletion
- inversion

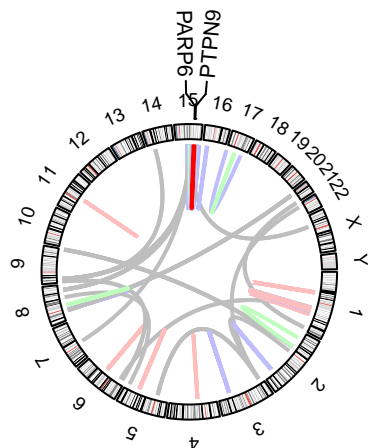
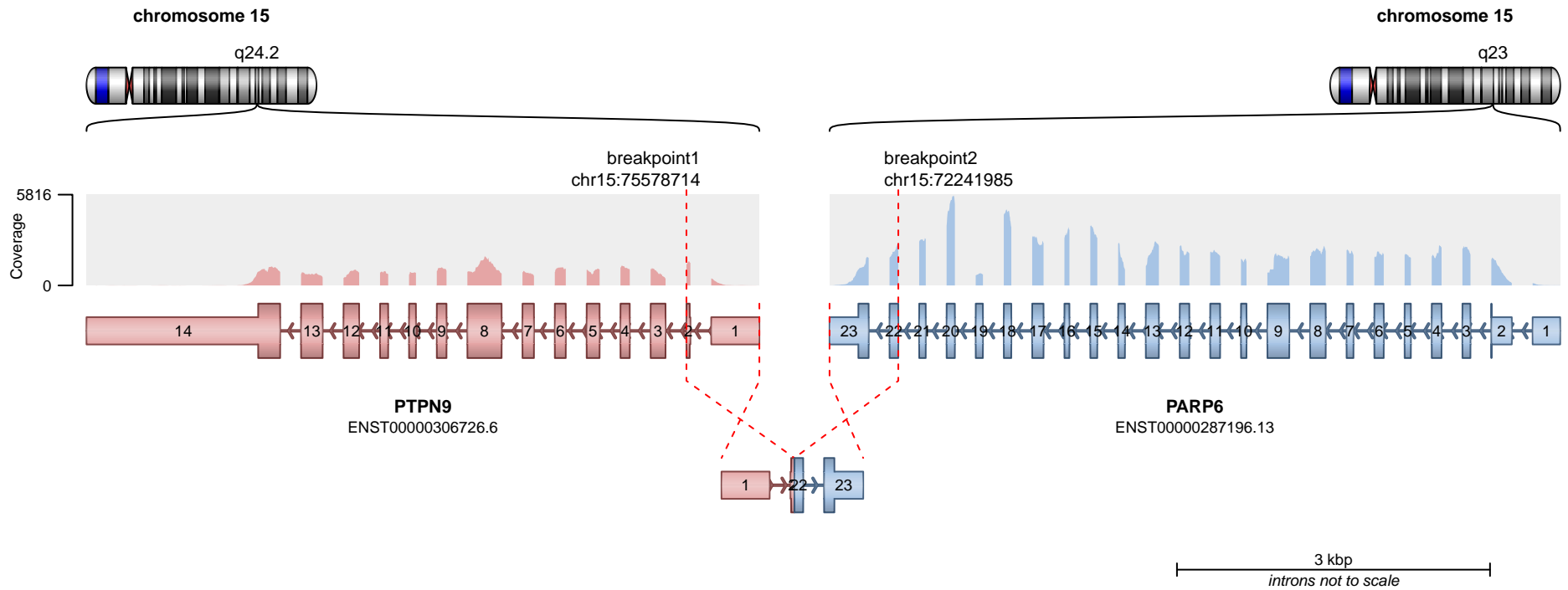

**RETAINED PROTEIN DOMAINS**  
reading frame unclear

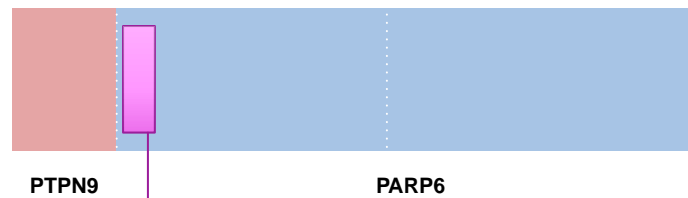

**SUPPORTING READ COUNT**

Split reads = 1  
Discordant mates = 0

— translocation — deletion  
— duplication — inversion

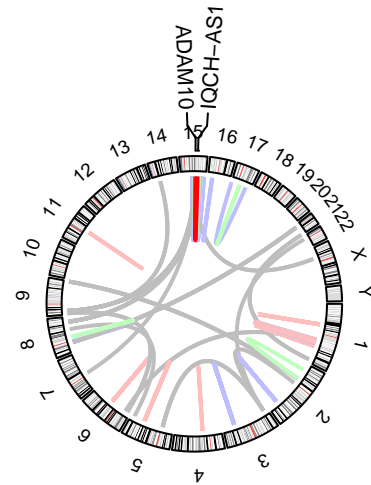
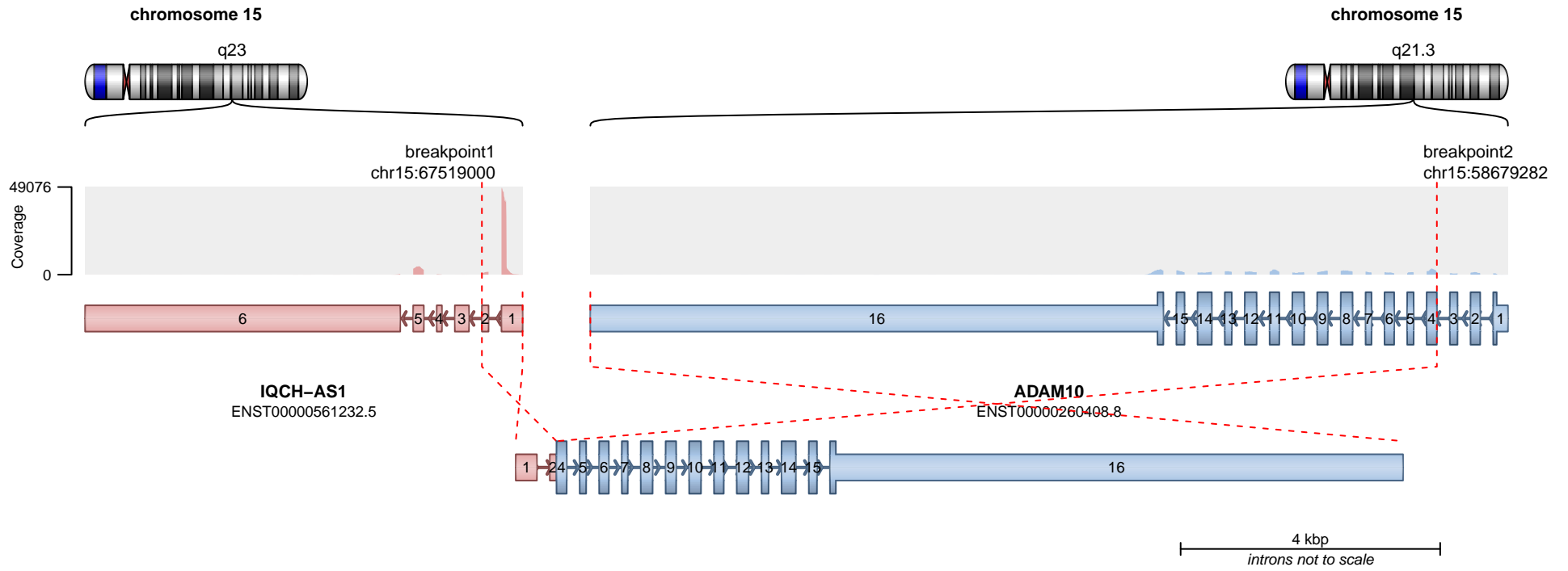

— translocation    — deletion  
— duplication    — inversion

**RETAINED PROTEIN DOMAINS**  
reading frame unclear

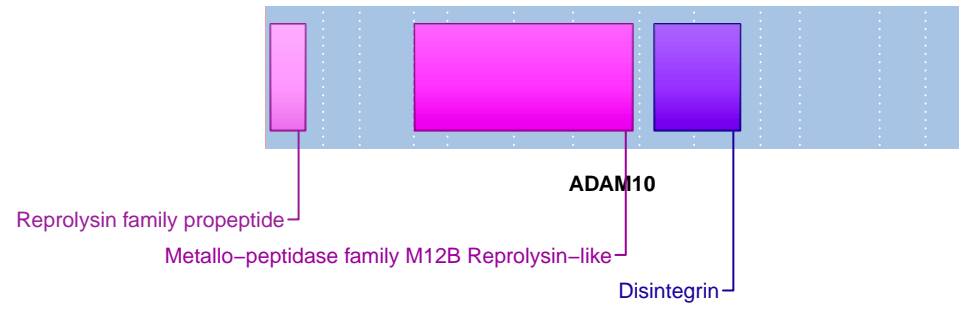

**SUPPORTING READ COUNT**

Split reads = 233  
Discordant mates = 2

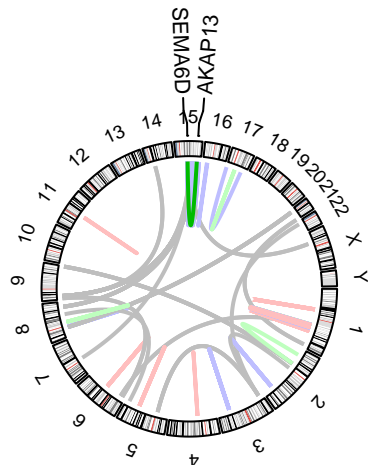
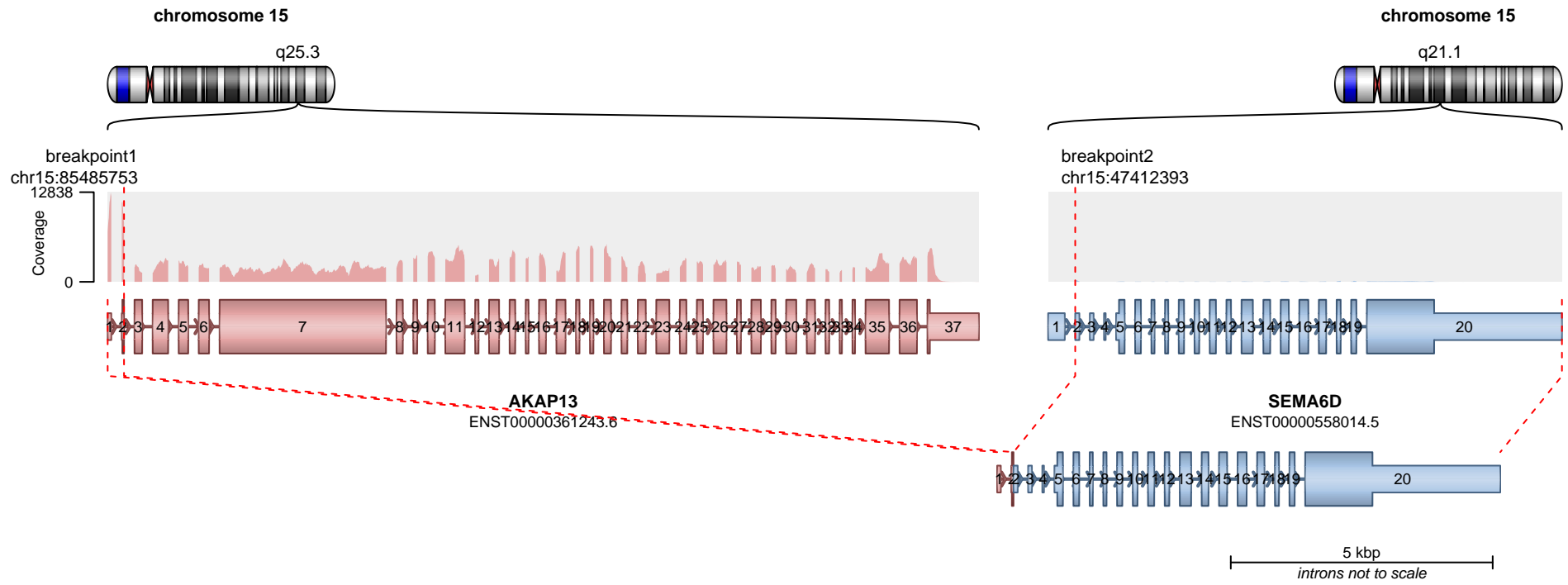

**RETAINED PROTEIN DOMAINS**  
reading frame unclear

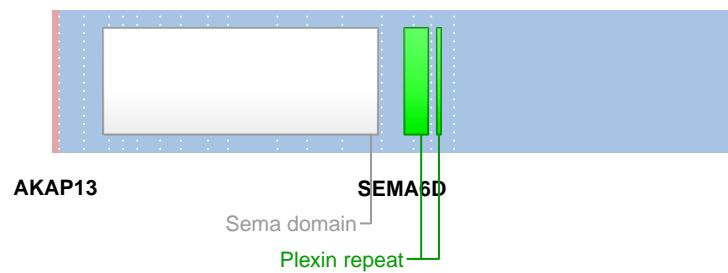

**SUPPORTING READ COUNT**

Split reads = 222  
Discordant mates = 1

- translocation
- duplication
- deletion
- inversion

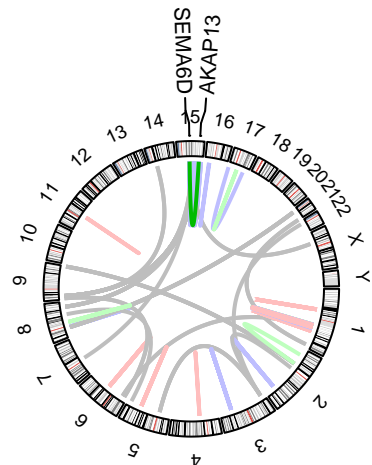
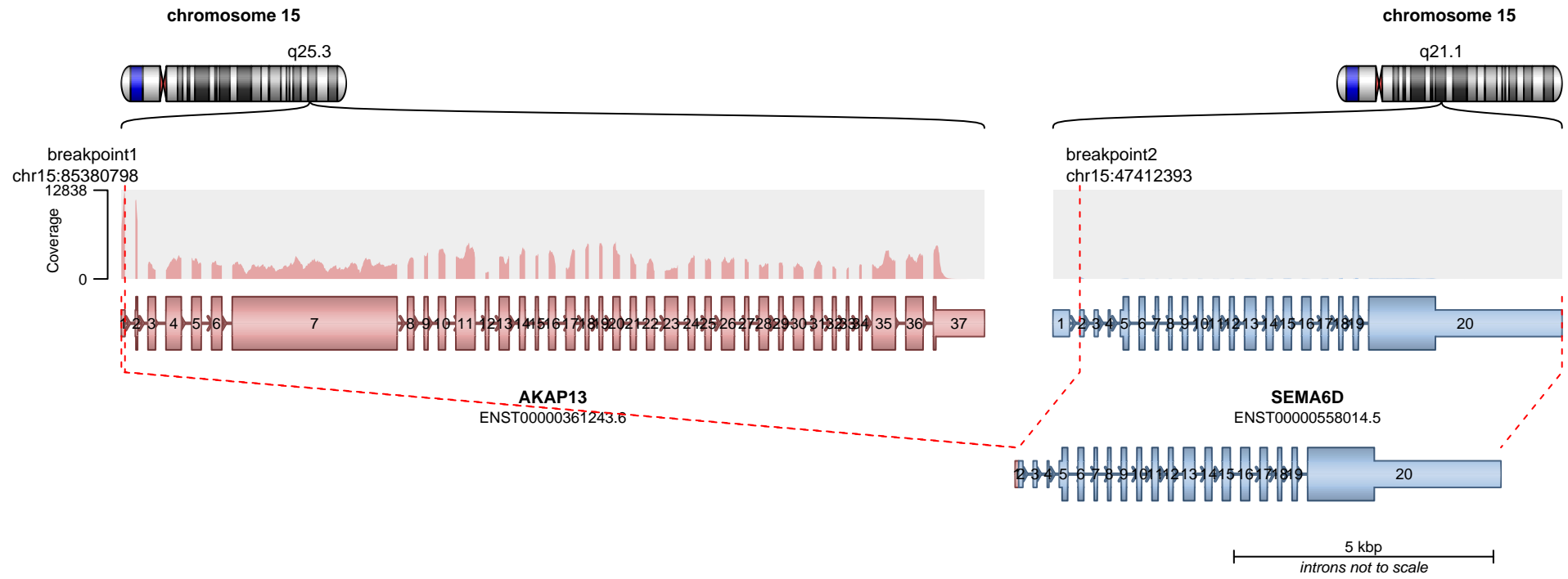

**RETAINED PROTEIN DOMAINS**  
reading frame unclear

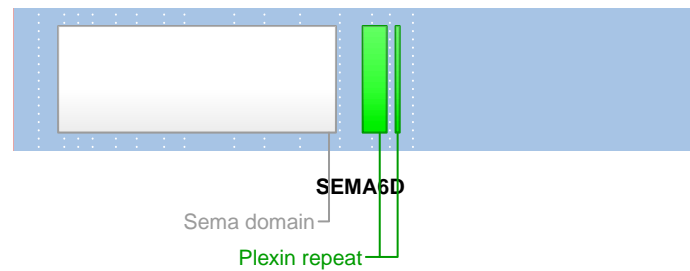

**SUPPORTING READ COUNT**

Split reads = 1  
Discordant mates = 1

— translocation    — deletion  
— duplication    — inversion

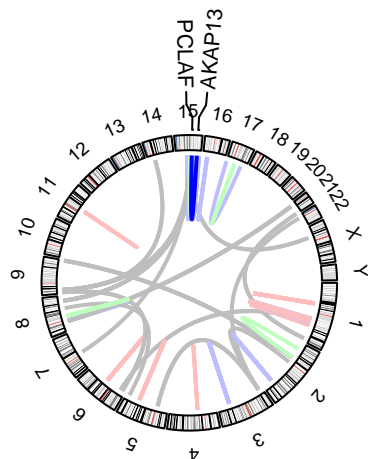
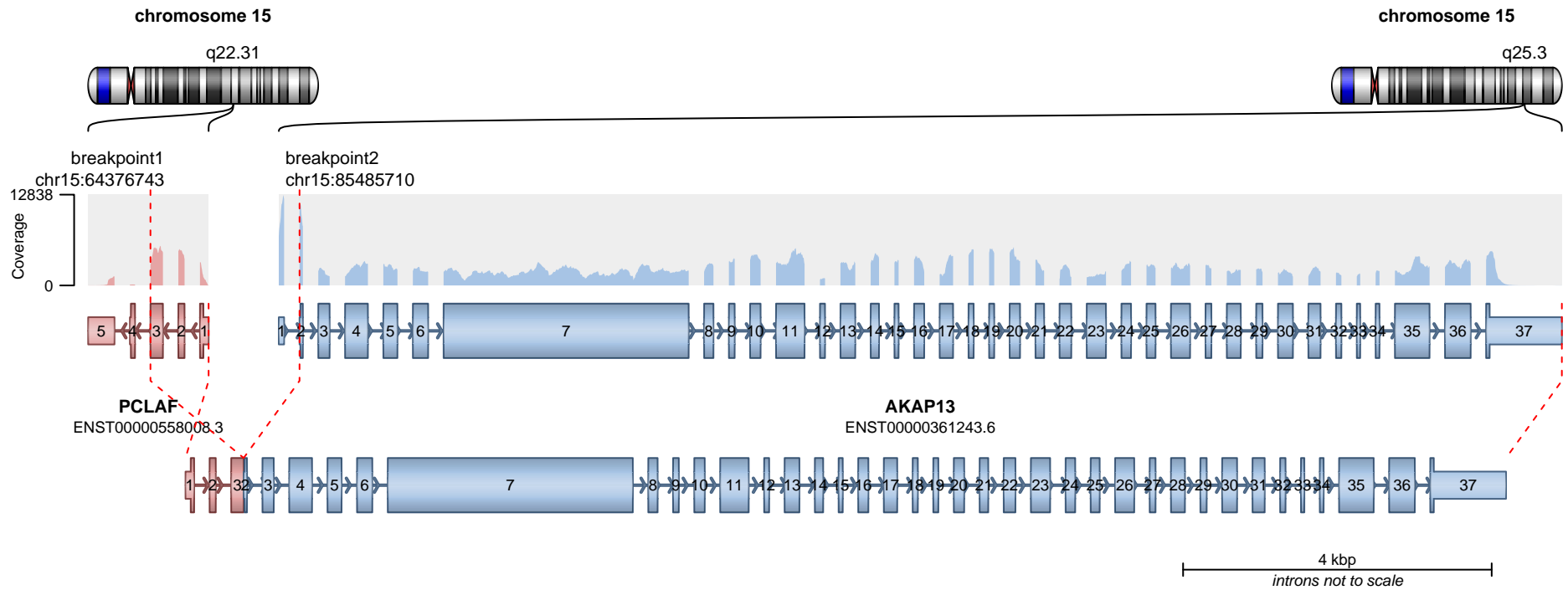

**RETAINED PROTEIN DOMAINS**  
 reading frame unclear

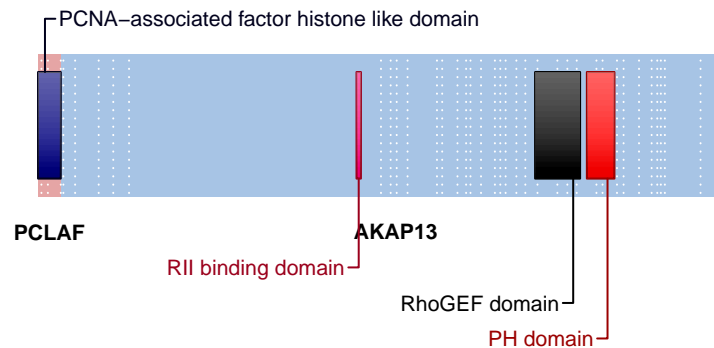

**SUPPORTING READ COUNT**

Split reads = 184  
 Discordant mates = 1

- translocation
- duplication
- deletion
- inversion

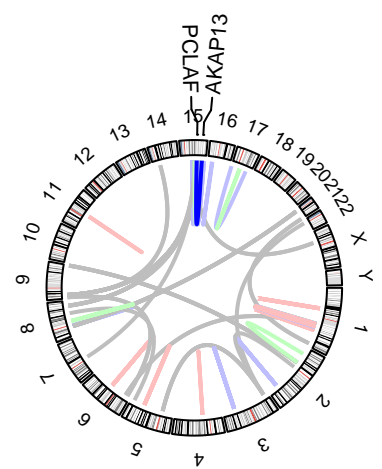
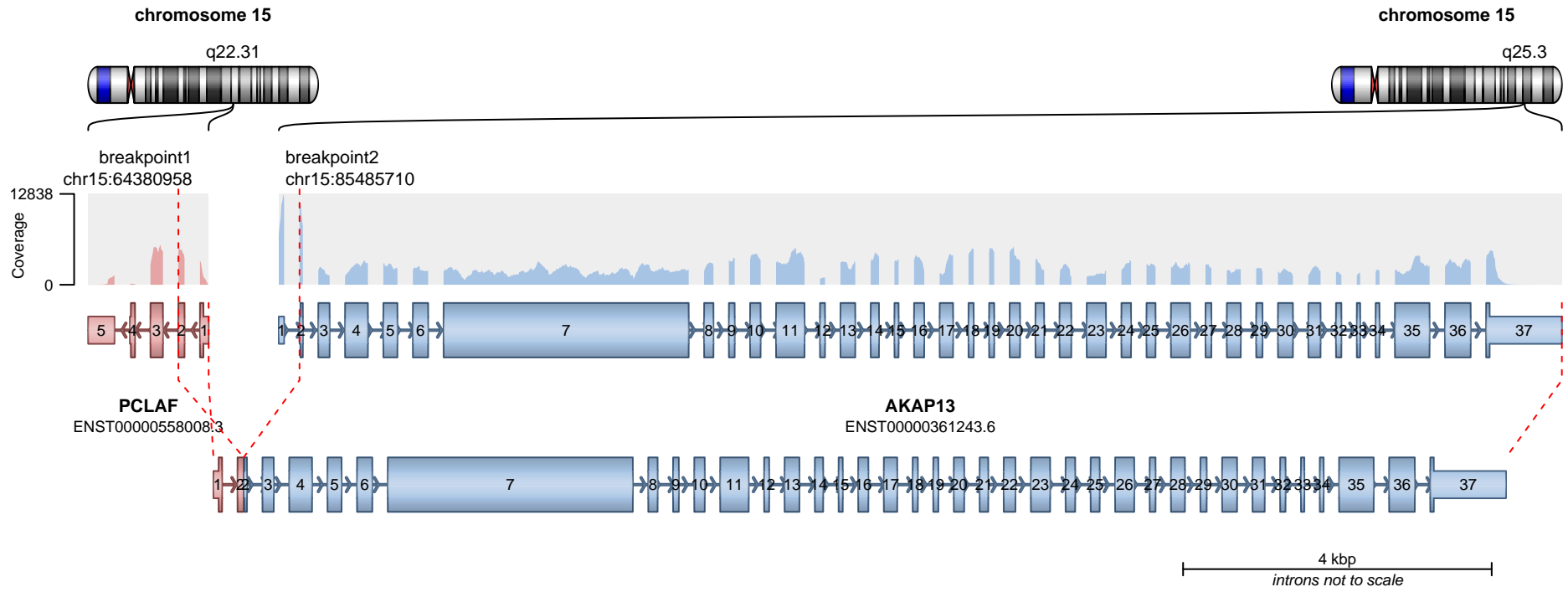

— translocation — deletion  
 — duplication — inversion

**RETAINED PROTEIN DOMAINS**  
 reading frame unclear

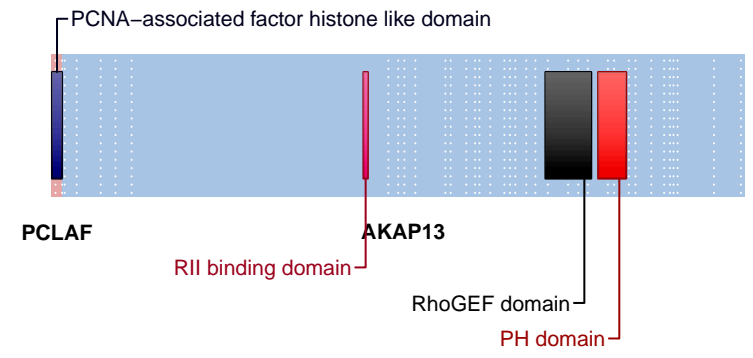

**SUPPORTING READ COUNT**

Split reads = 1  
 Discordant mates = 0

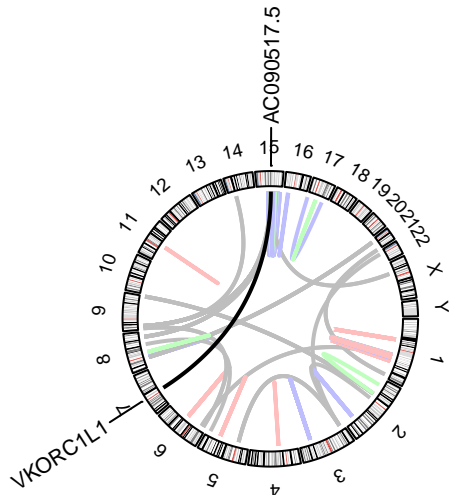
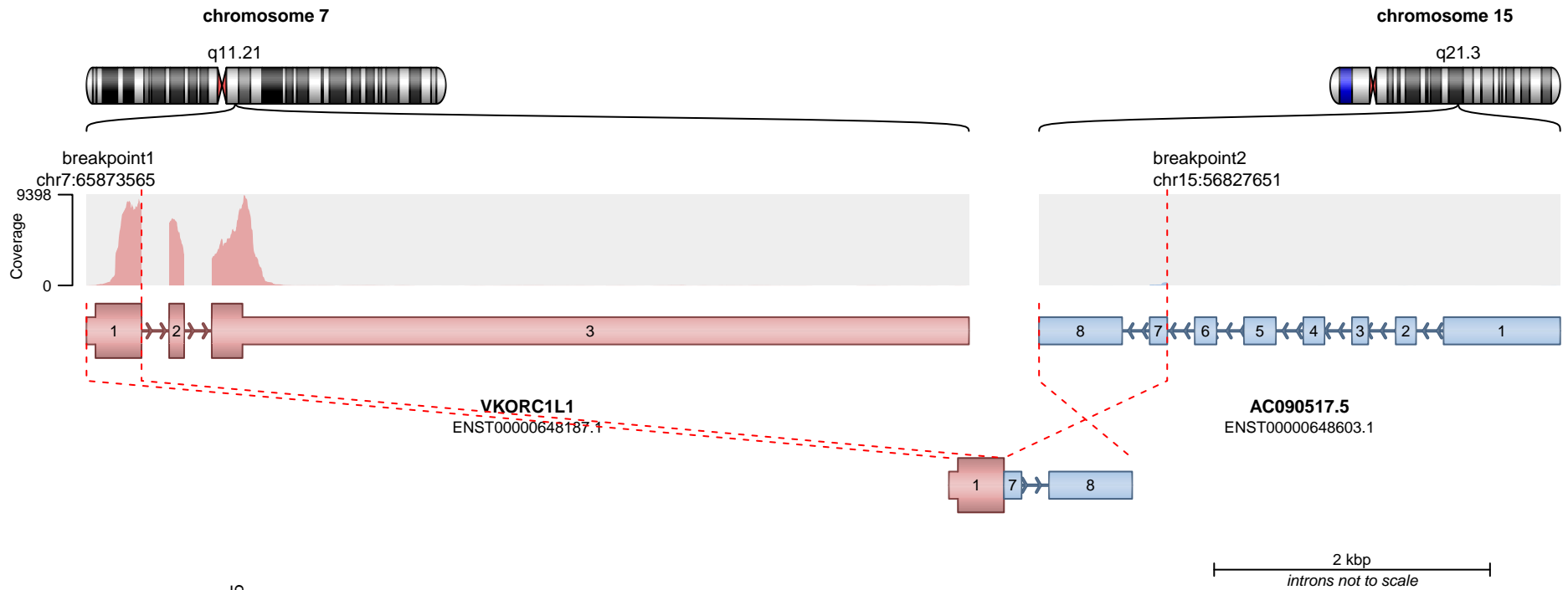

**RETAINED PROTEIN DOMAINS**  
reading frame unclear

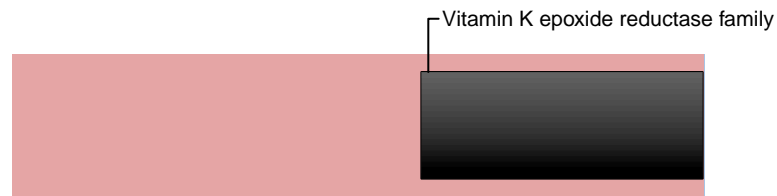

**VKORC1L1**

**SUPPORTING READ COUNT**

Split reads = 178  
Discordant mates = 4

— translocation    — deletion  
— duplication    — inversion

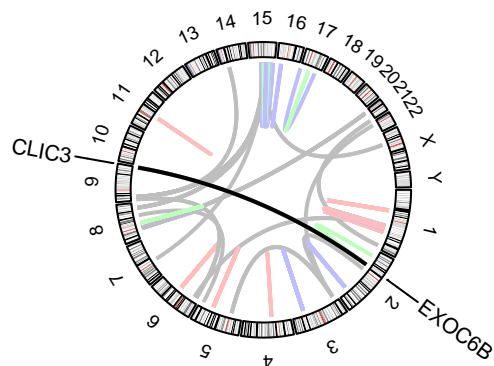
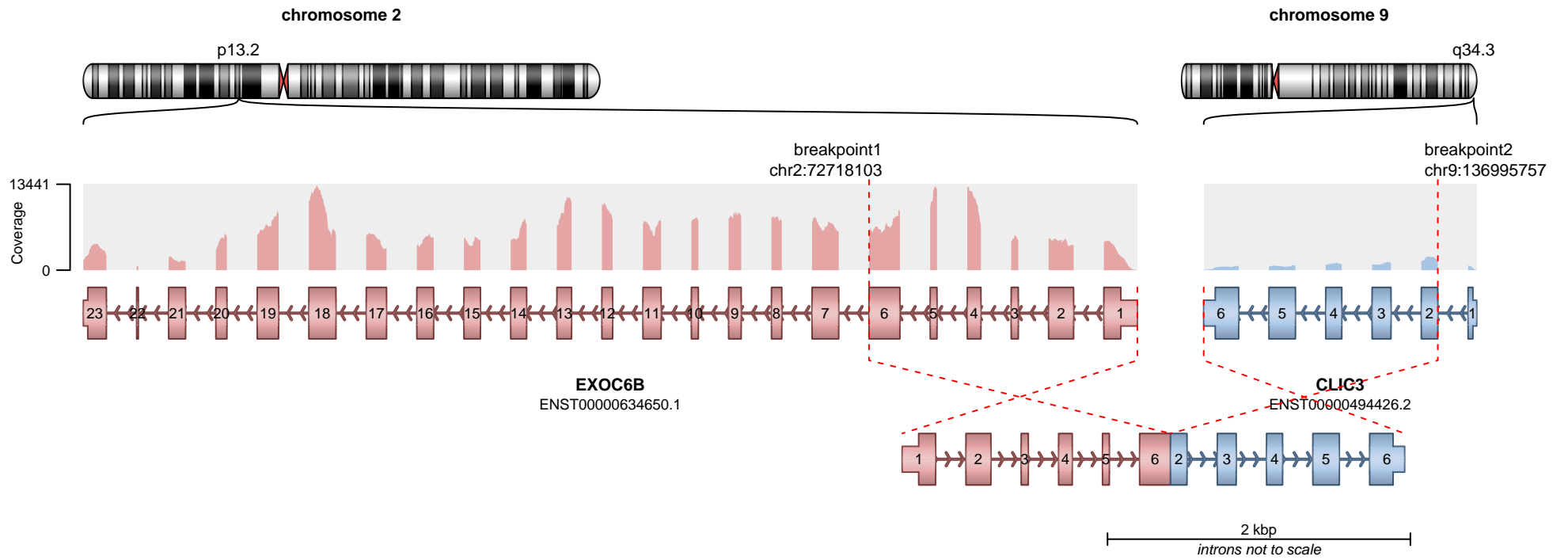

**RETAINED PROTEIN DOMAINS**  
reading frame unclear

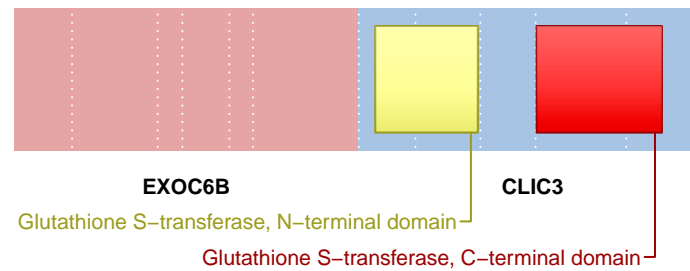

**SUPPORTING READ COUNT**

Split reads = 177  
Discordant mates = 3

- translocation
- duplication
- deletion
- inversion

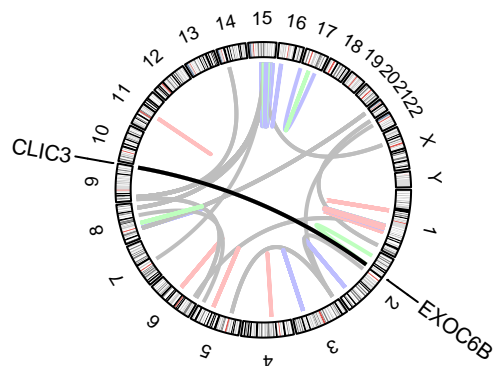
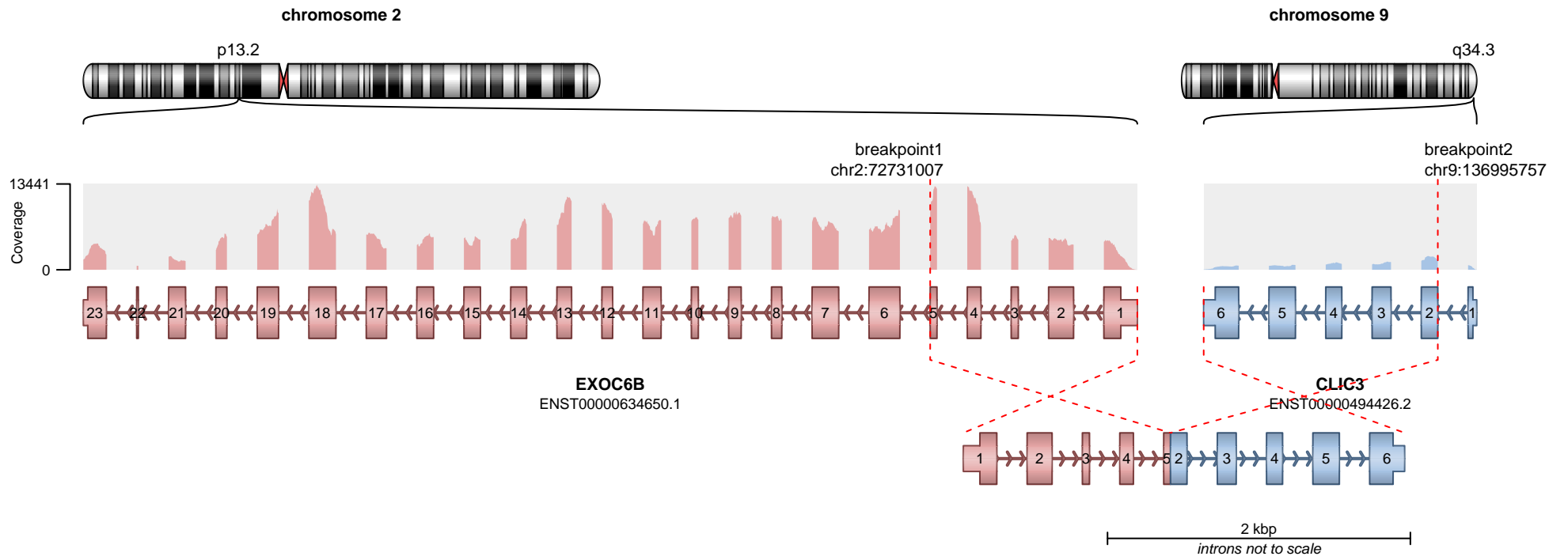

**RETAINED PROTEIN DOMAINS**  
reading frame unclear

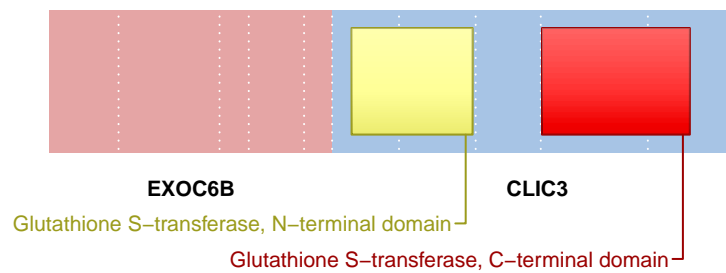

**SUPPORTING READ COUNT**

Split reads = 4  
Discordant mates = 0

- translocation
- duplication
- deletion
- inversion

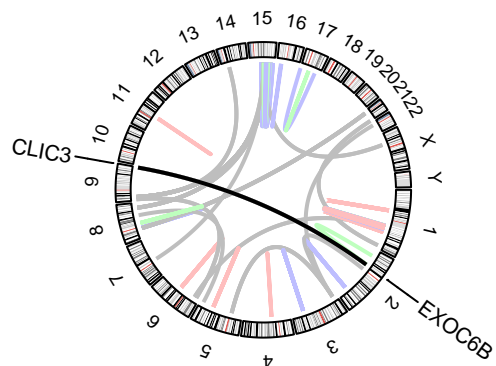
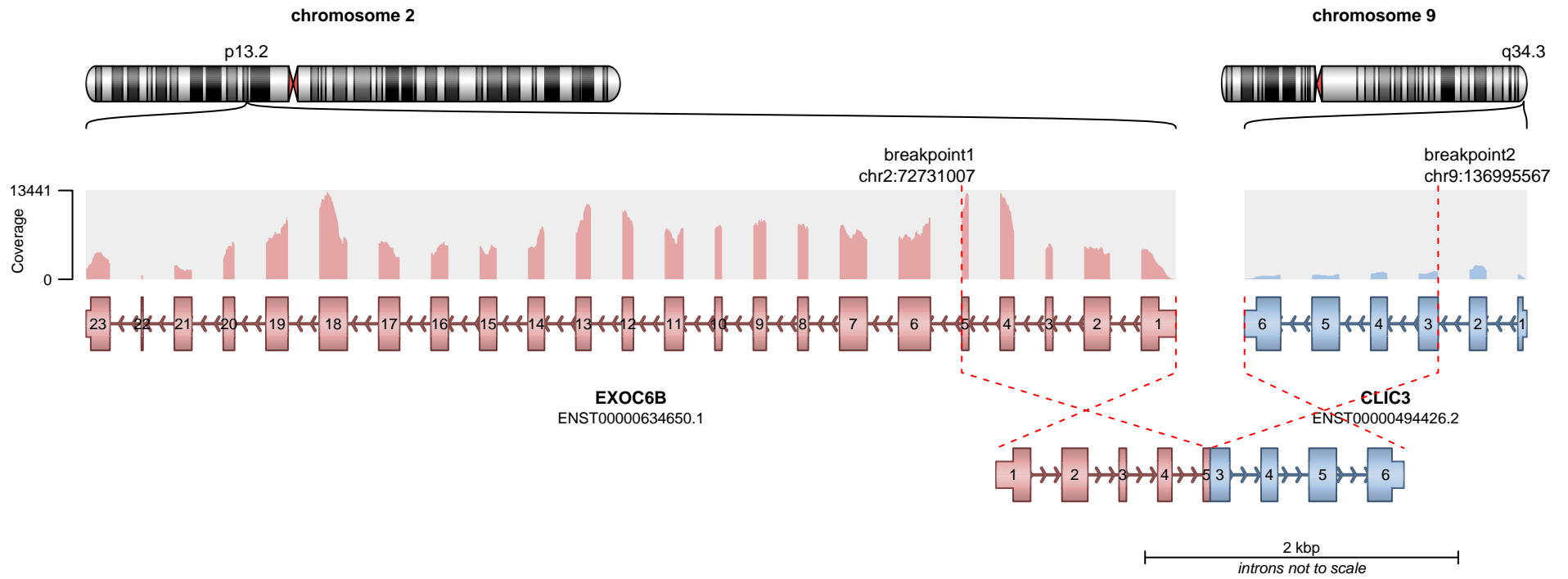

**RETAINED PROTEIN DOMAINS**  
reading frame unclear

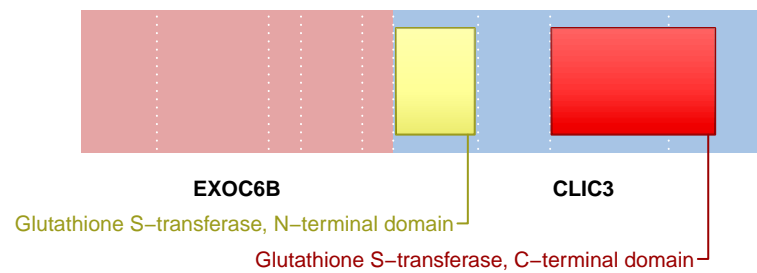

**SUPPORTING READ COUNT**

Split reads = 1  
Discordant mates = 0

- translocation
- duplication
- deletion
- inversion

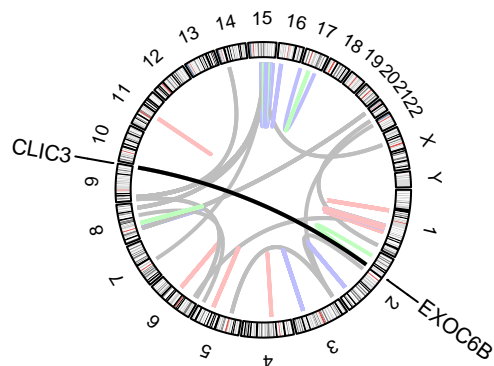
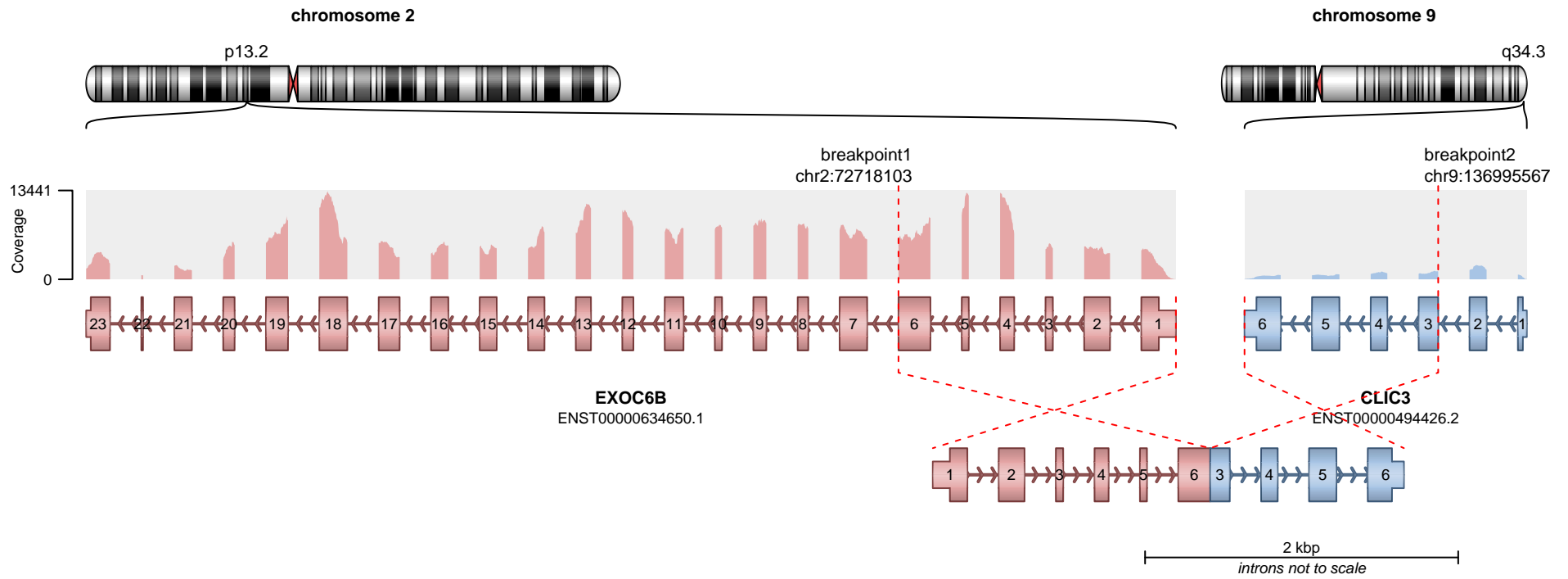

**RETAINED PROTEIN DOMAINS**  
reading frame unclear

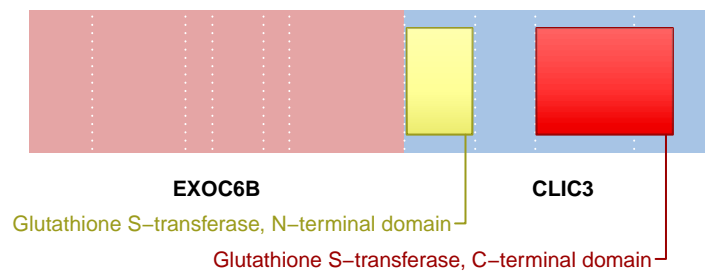

**SUPPORTING READ COUNT**

Split reads = 1  
Discordant mates = 0

- translocation
- duplication
- deletion
- inversion

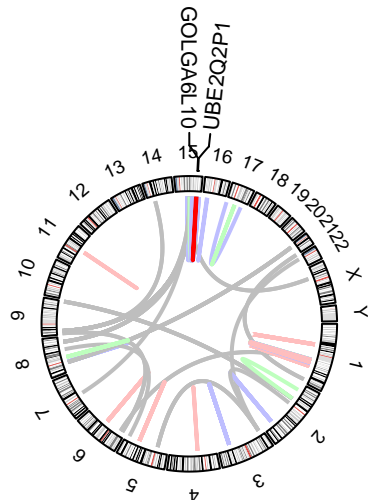
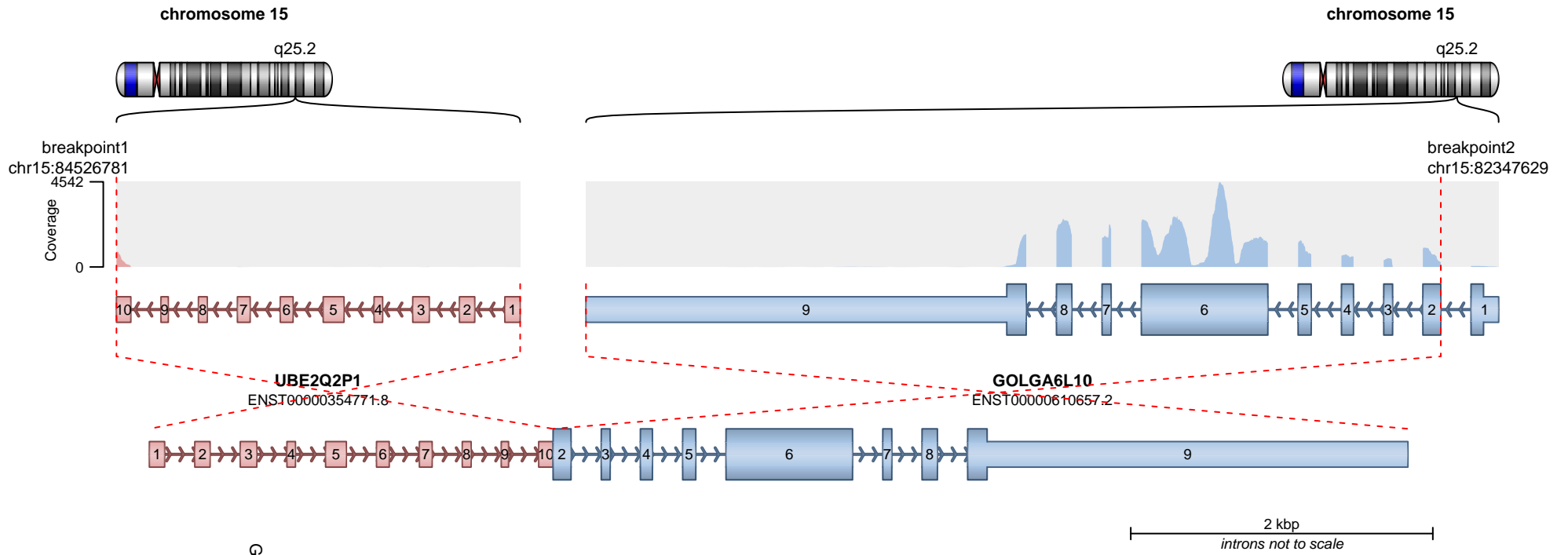

**RETAINED PROTEIN DOMAINS**  
reading frame unclear

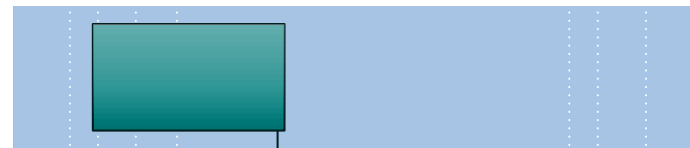

**SUPPORTING READ COUNT**

Split reads = 158  
Discordant mates = 0

Putative golgin subfamily A member 2-like protein 5

— translocation — deletion  
— duplication — inversion

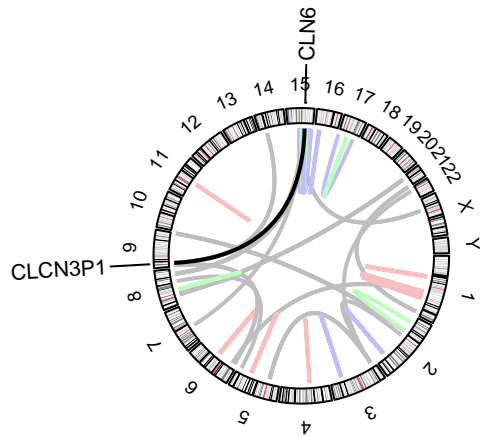
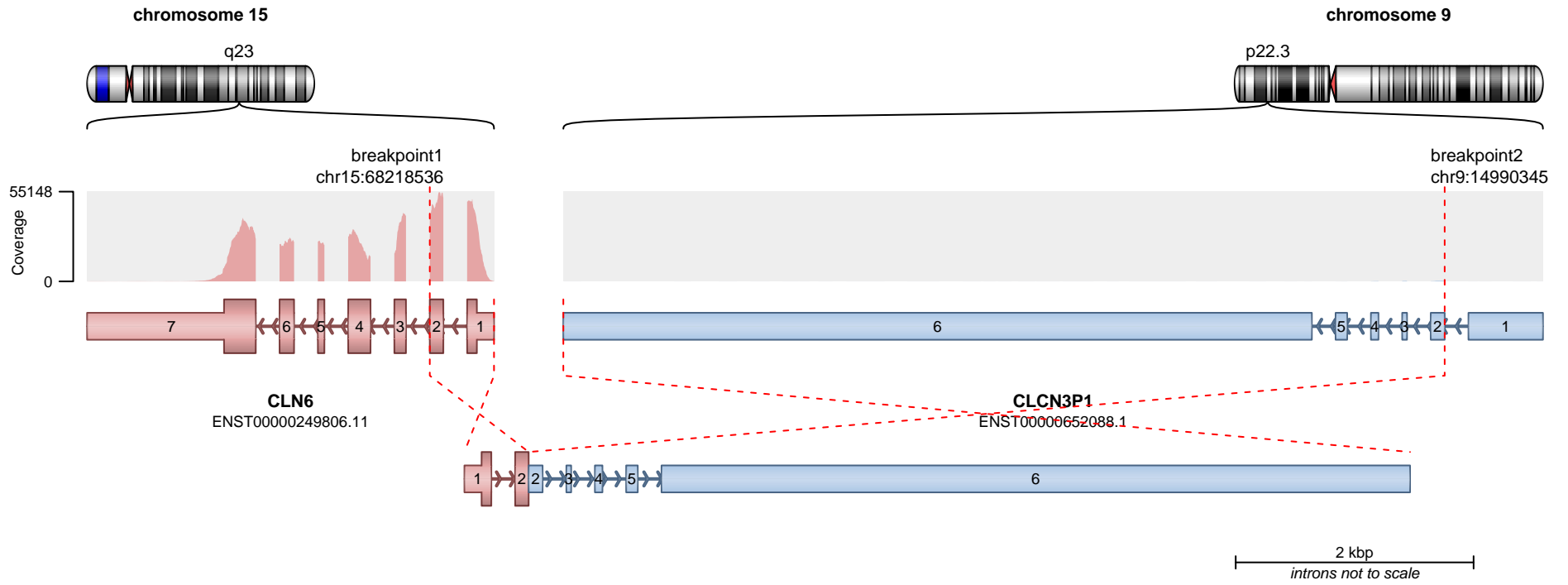

**RETAINED PROTEIN DOMAINS**  
reading frame unclear

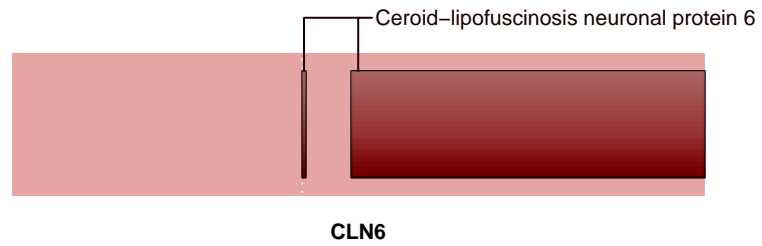

**SUPPORTING READ COUNT**

Split reads = 142  
Discordant mates = 17

— translocation    — deletion  
— duplication    — inversion

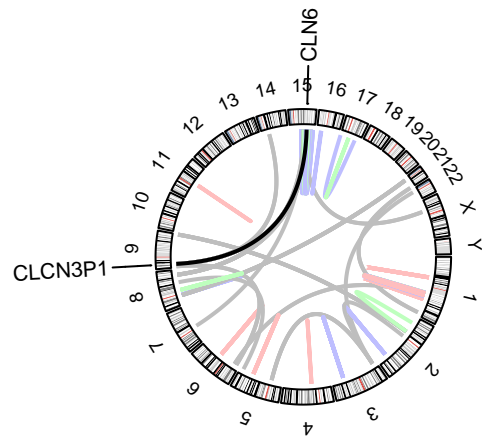
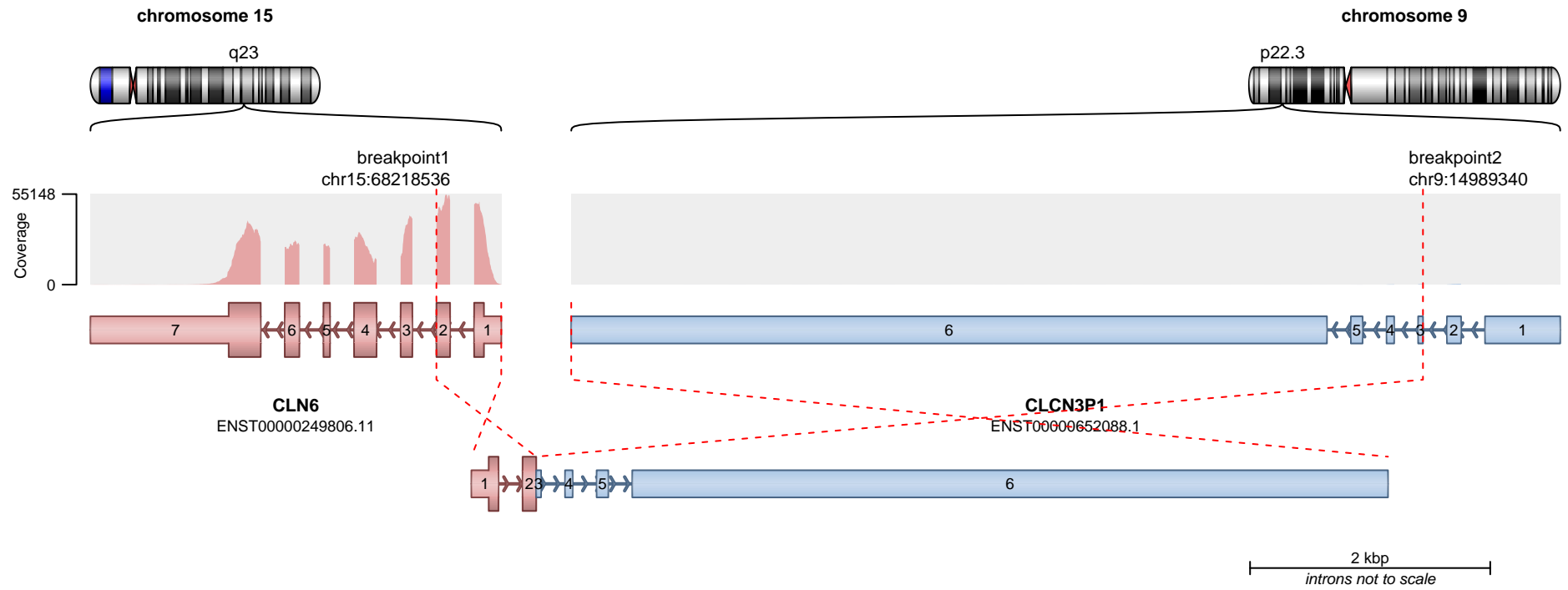

**RETAINED PROTEIN DOMAINS**  
reading frame unclear

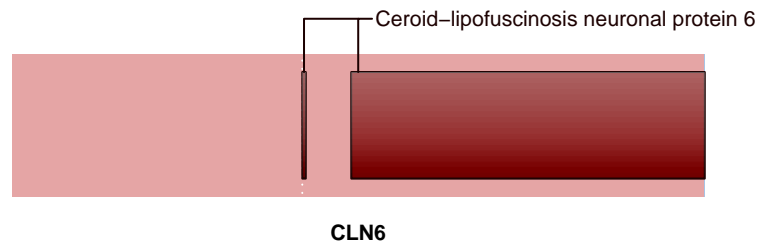

**SUPPORTING READ COUNT**

Split reads = 101  
Discordant mates = 2

— translocation    — deletion  
— duplication    — inversion

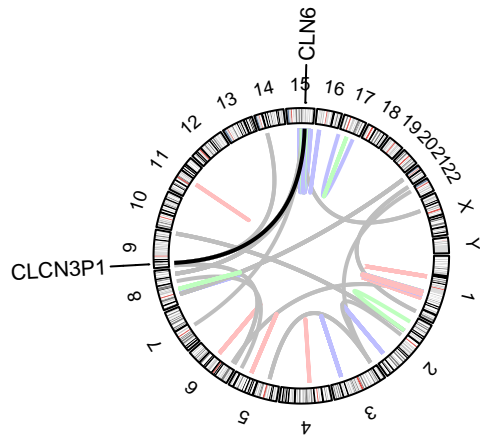
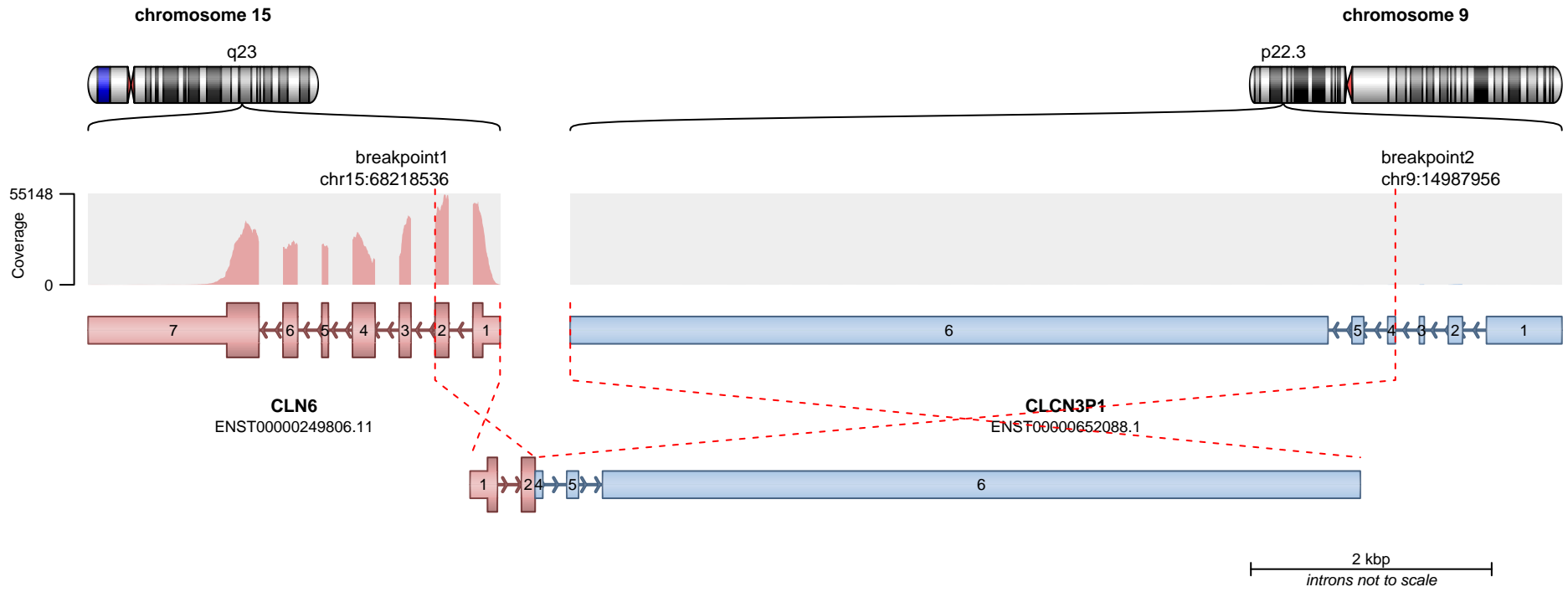

— translocation    — deletion  
— duplication      — inversion

**RETAINED PROTEIN DOMAINS**  
reading frame unclear

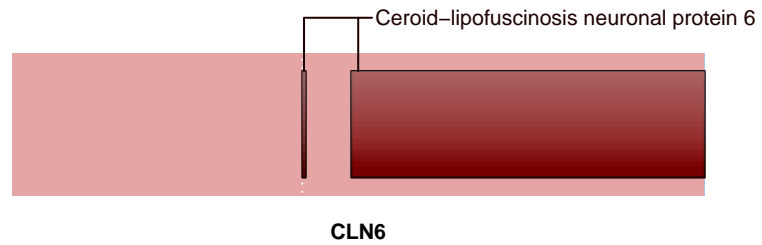

**SUPPORTING READ COUNT**

Split reads = 57  
Discordant mates = 1

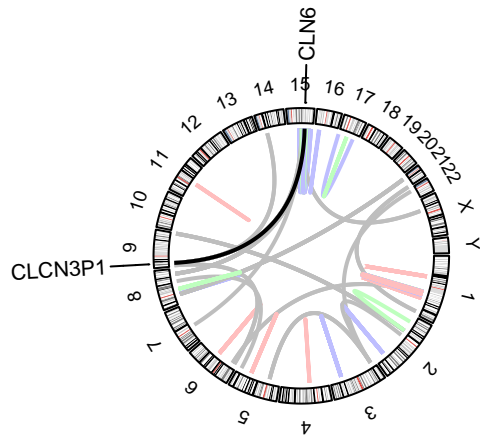
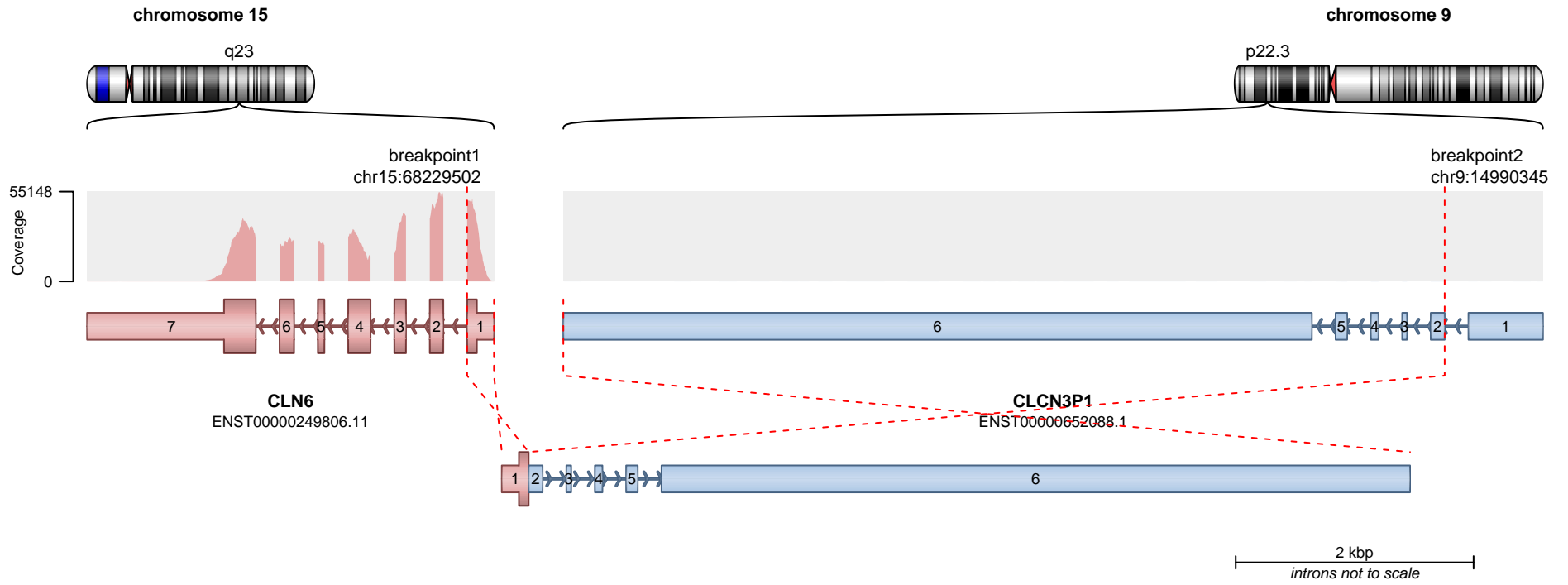

— translocation — deletion  
— duplication — inversion

**RETAINED PROTEIN DOMAINS**  
reading frame unclear



Ceroid-lipofuscinosis neuronal protein 6

**SUPPORTING READ COUNT**

Split reads = 44  
Discordant mates = 1

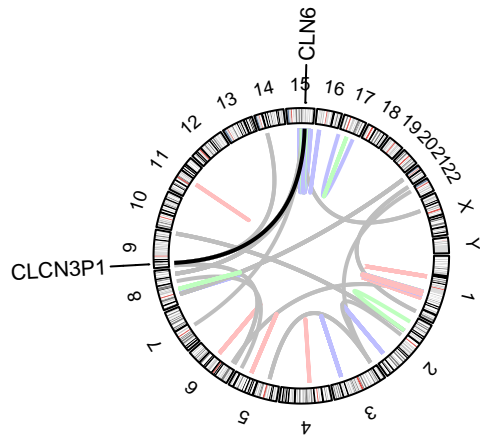
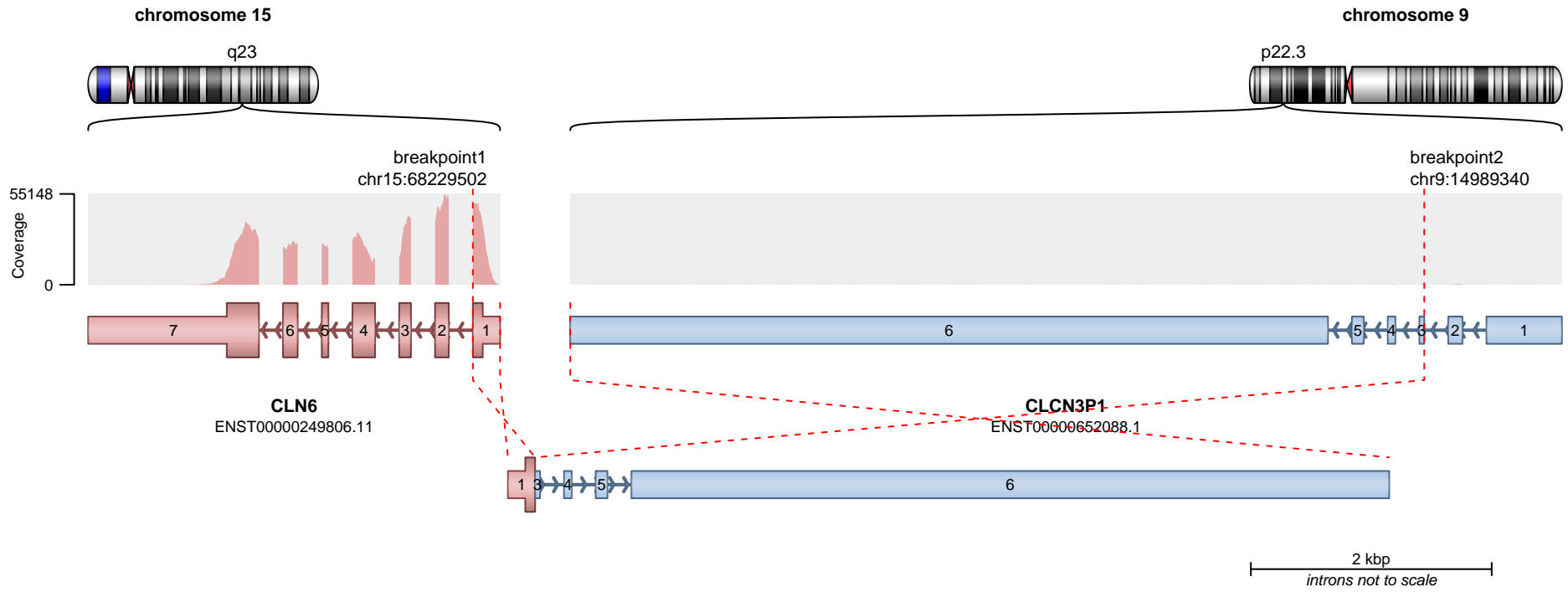

**RETAINED PROTEIN DOMAINS**  
reading frame unclear



Ceroid-lipofuscinosis neuronal protein 6

**SUPPORTING READ COUNT**

Split reads = 31  
Discordant mates = 0

— translocation — deletion  
— duplication — inversion

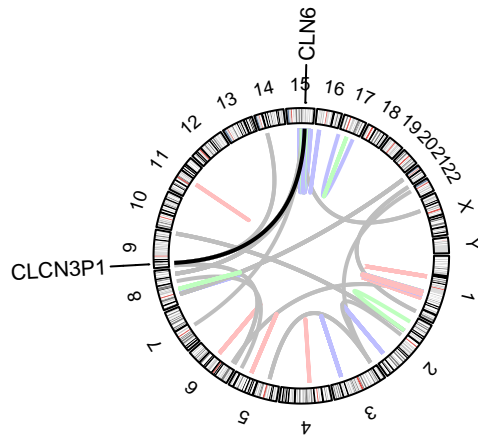
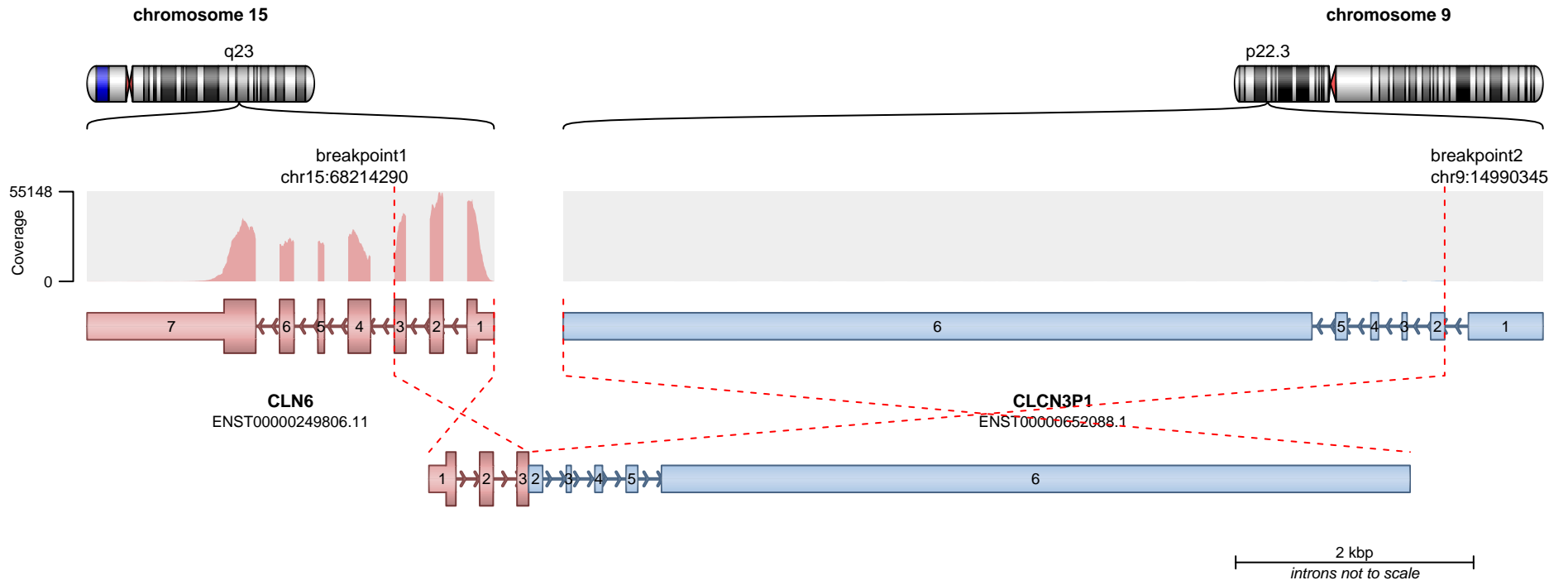

— translocation    — deletion  
— duplication      — inversion

**RETAINED PROTEIN DOMAINS**  
reading frame unclear

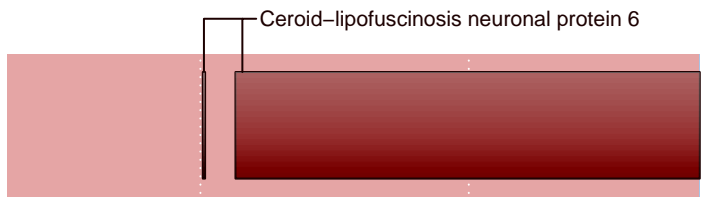

**SUPPORTING READ COUNT**

Split reads = 2  
Discordant mates = 17

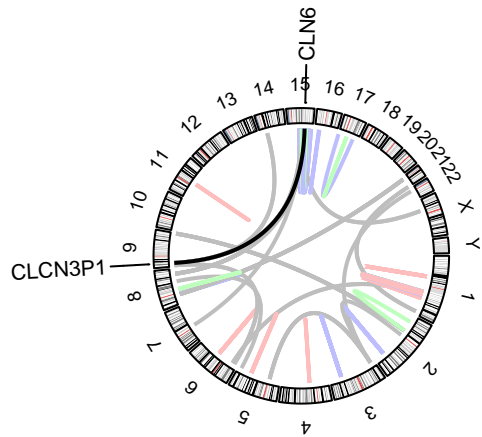
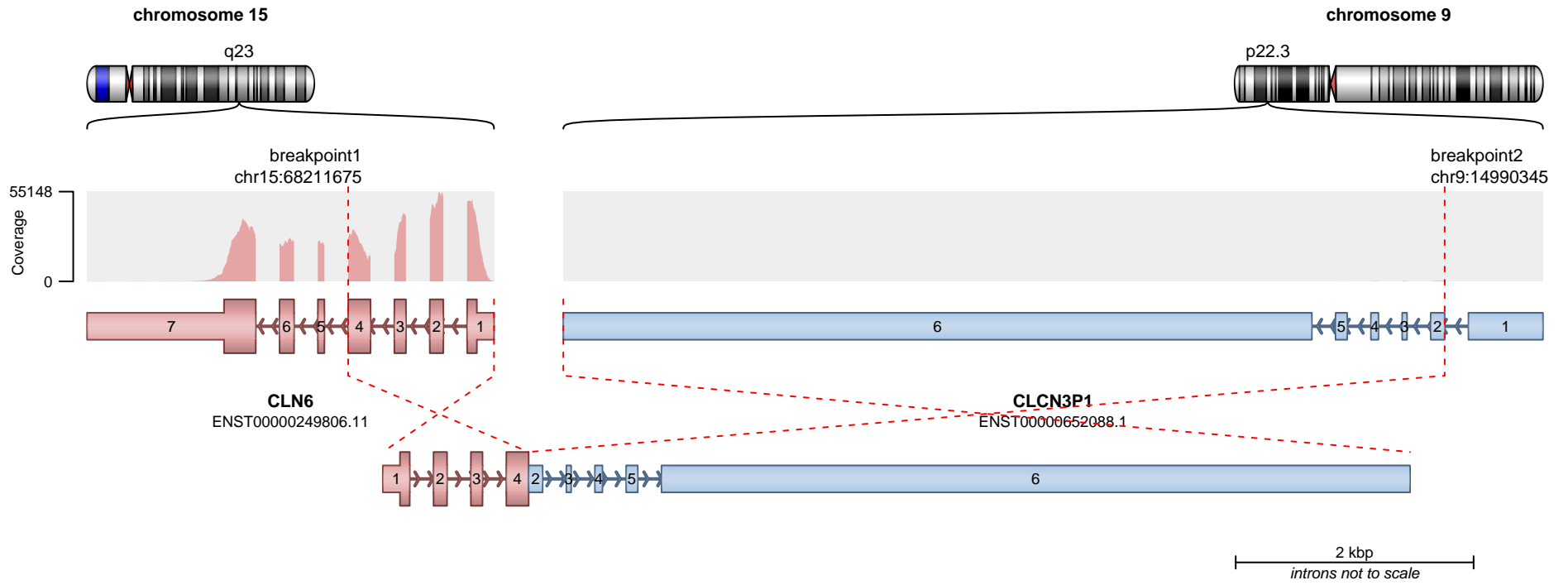

**RETAINED PROTEIN DOMAINS**  
reading frame unclear

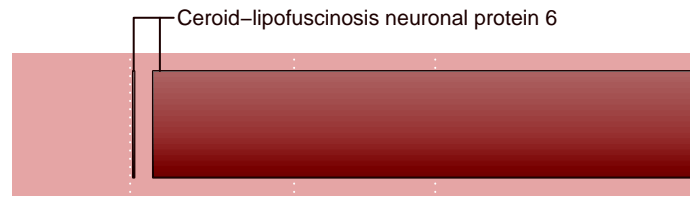

**SUPPORTING READ COUNT**

Split reads = 1  
Discordant mates = 17

- translocation
- duplication
- deletion
- inversion

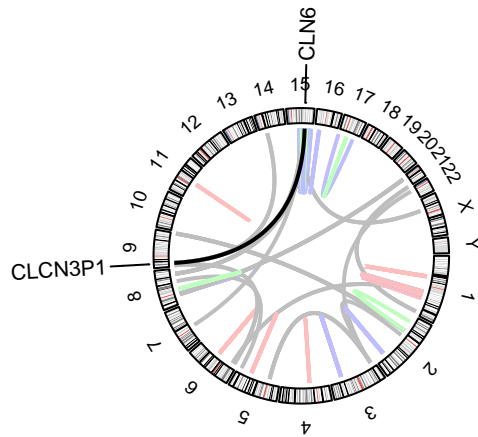
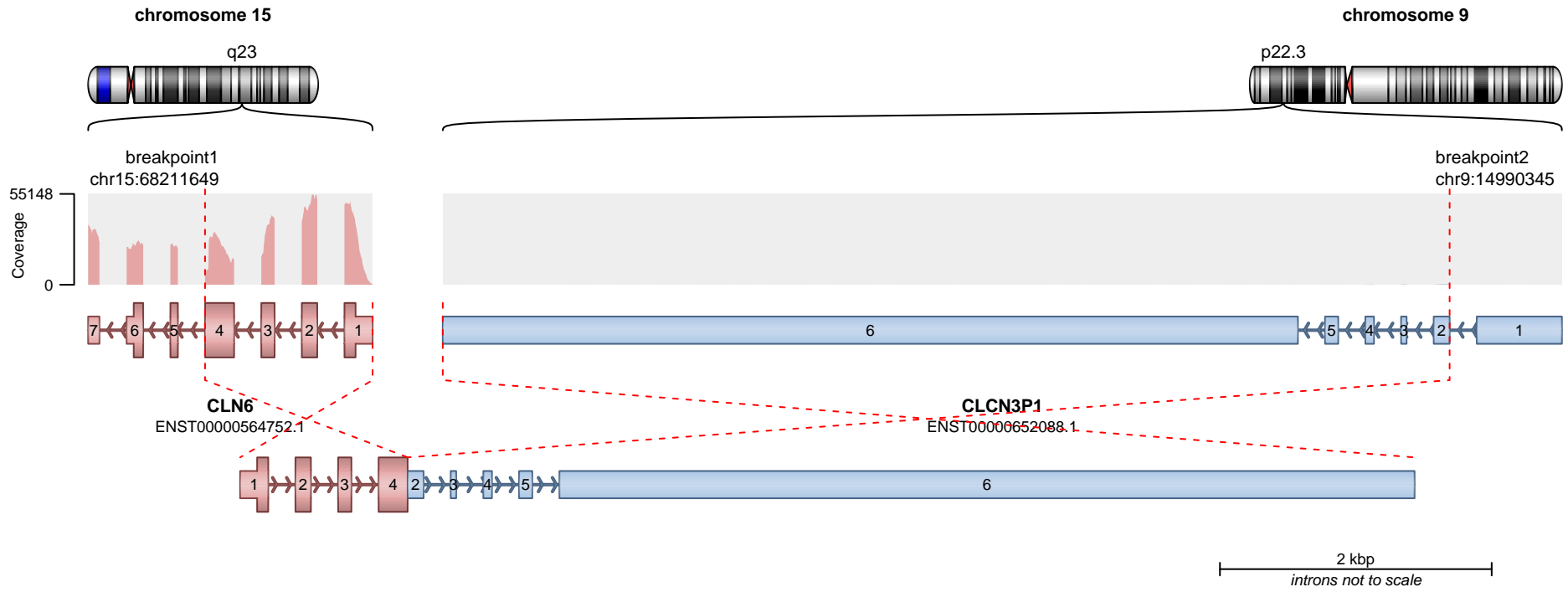

— translocation    — deletion  
— duplication    — inversion

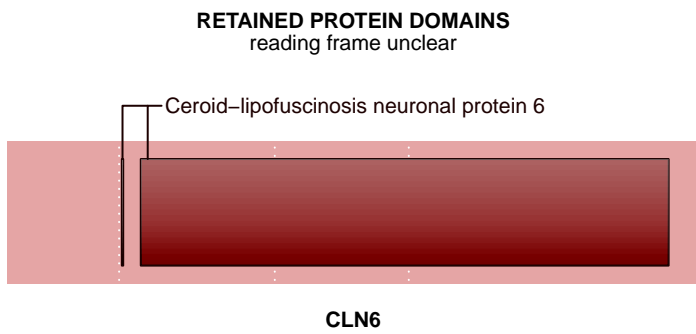

**SUPPORTING READ COUNT**

Split reads = 1  
Discordant mates = 17

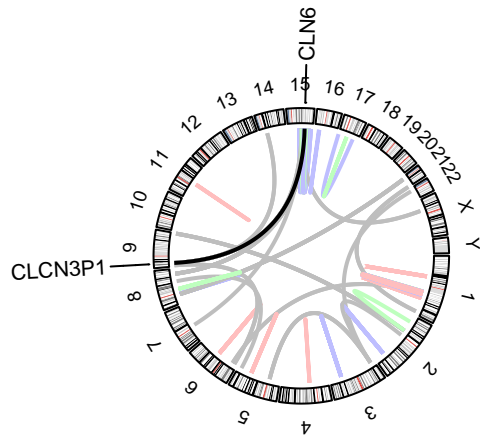
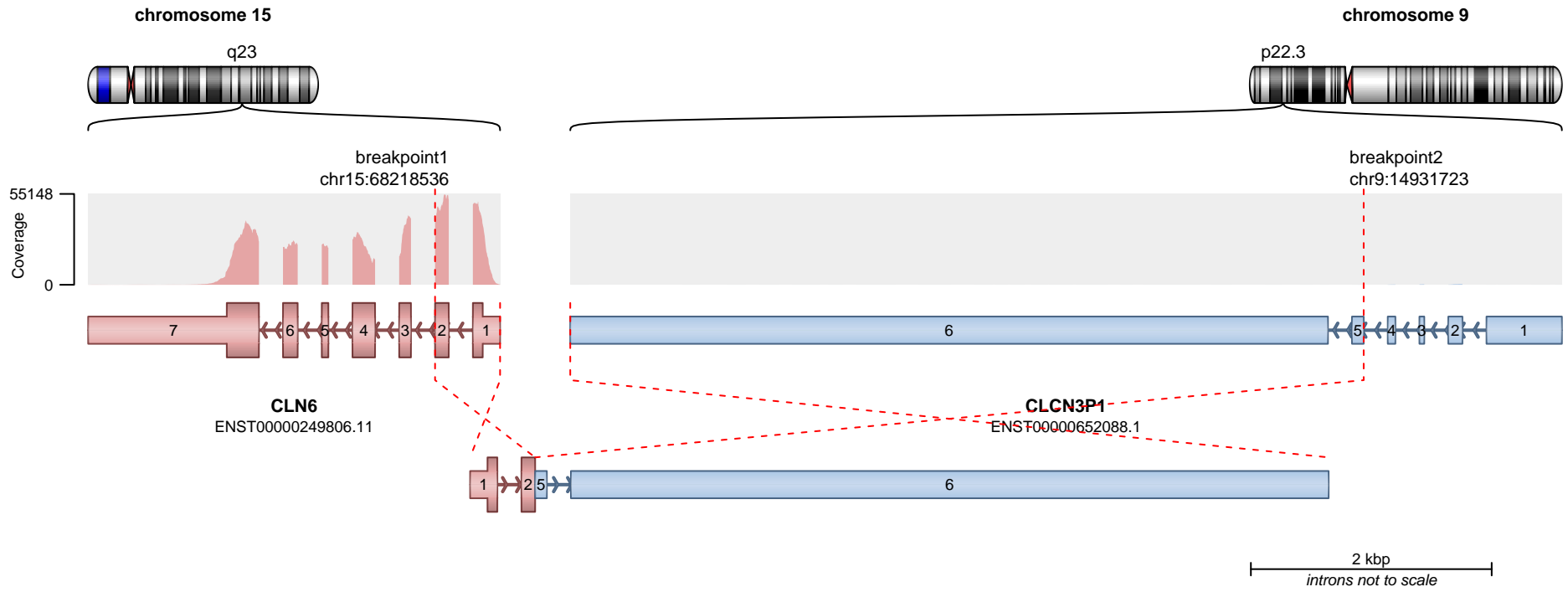

**RETAINED PROTEIN DOMAINS**  
reading frame unclear

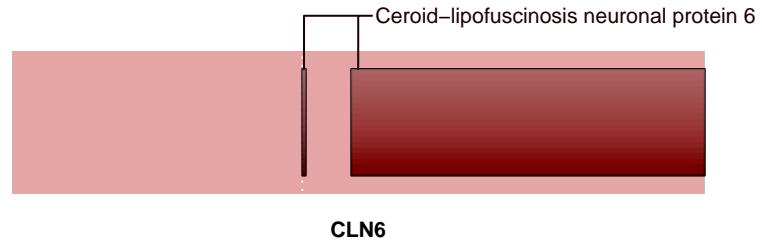

**SUPPORTING READ COUNT**

Split reads = 3  
Discordant mates = 0

— translocation    — deletion  
— duplication    — inversion

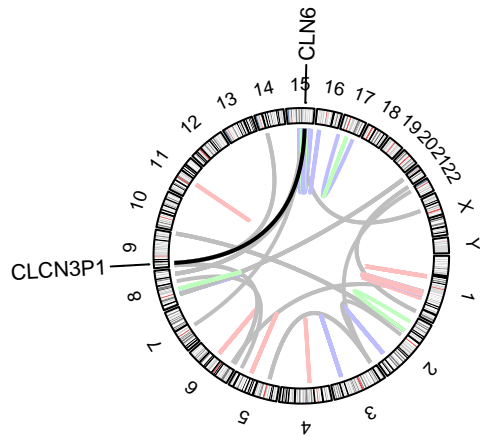
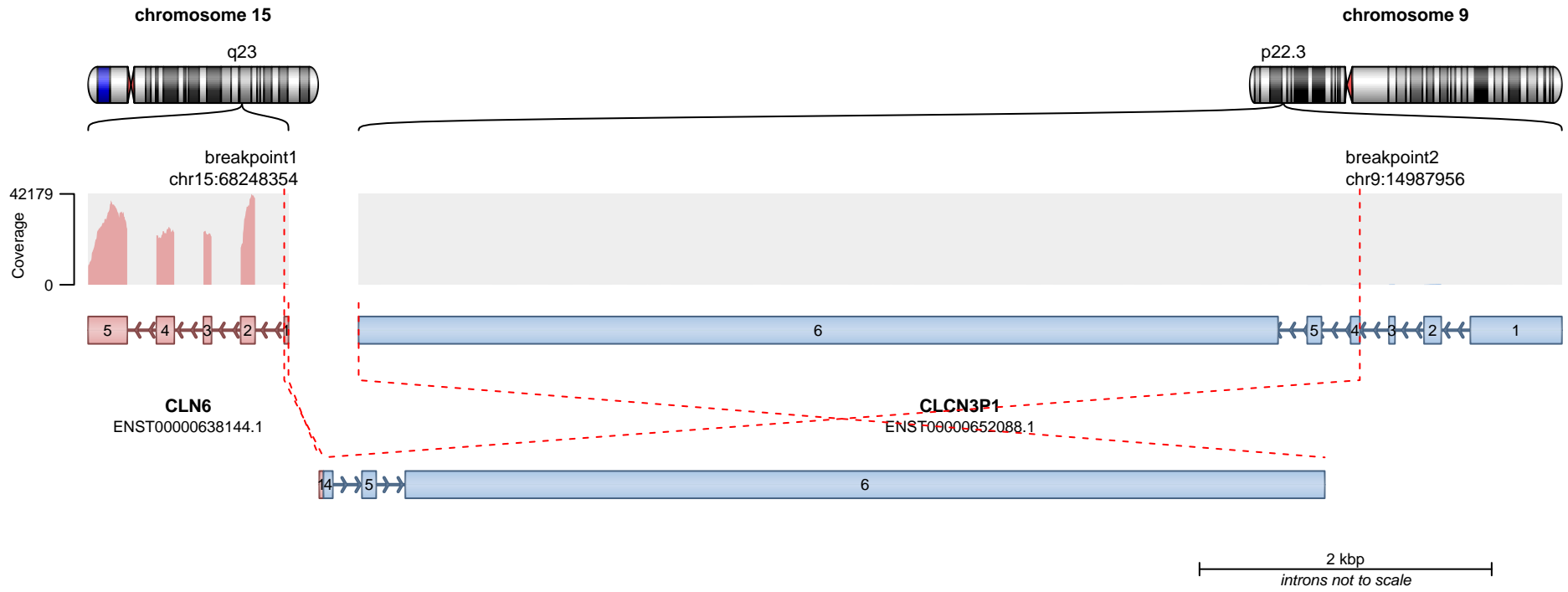

— translocation    — deletion  
— duplication    — inversion

Genes are not protein-coding.

**SUPPORTING READ COUNT**

Split reads = 1  
Discordant mates = 0

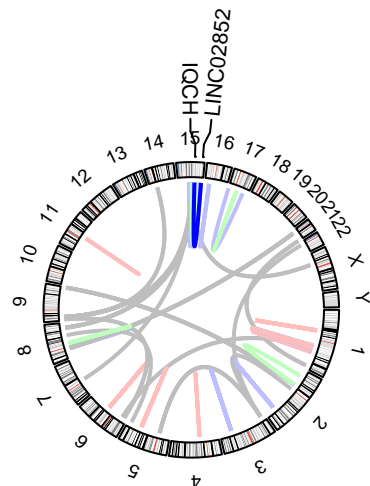
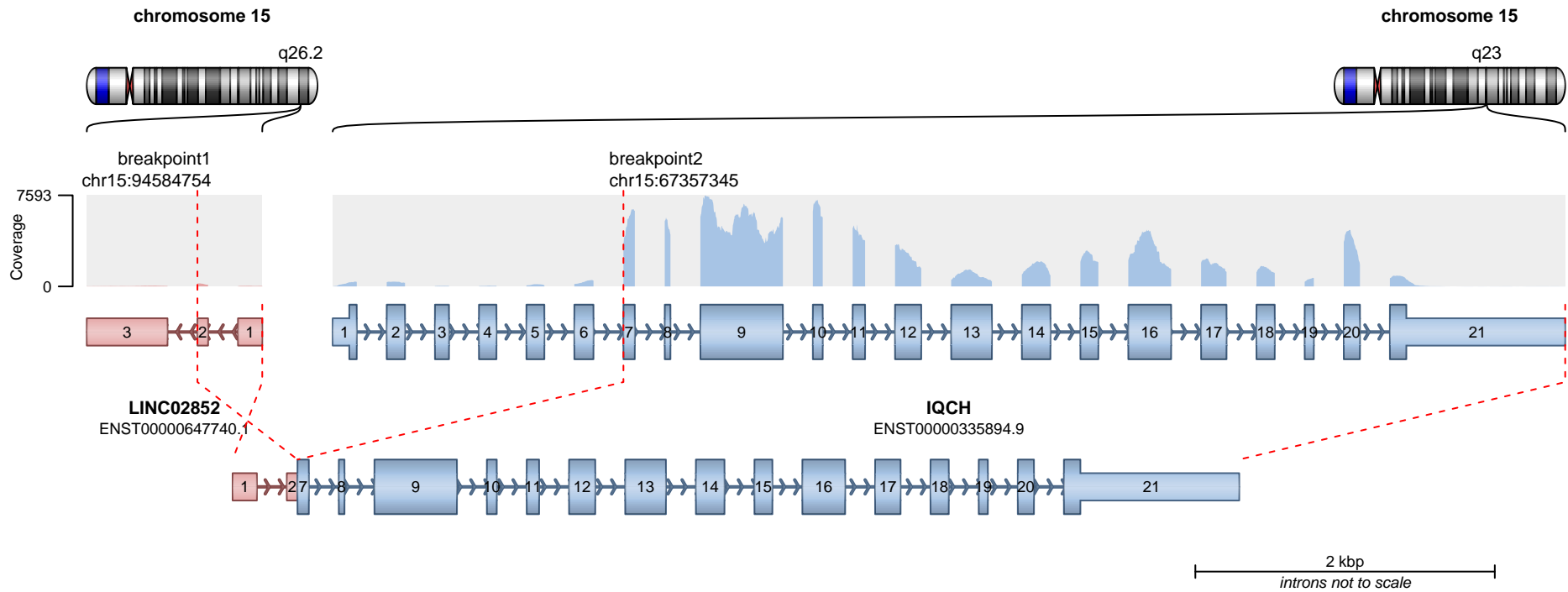

— translocation    — deletion  
— duplication    — inversion

No protein domains retained in fusion.

**SUPPORTING READ COUNT**

Split reads = 144  
Discordant mates = 0

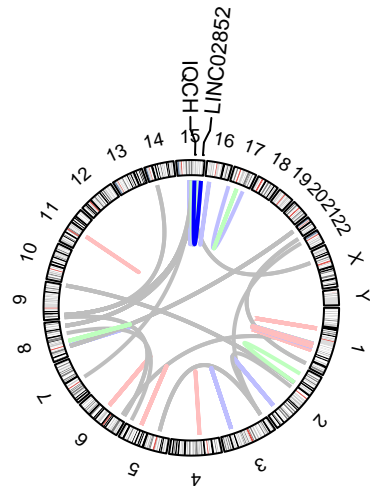
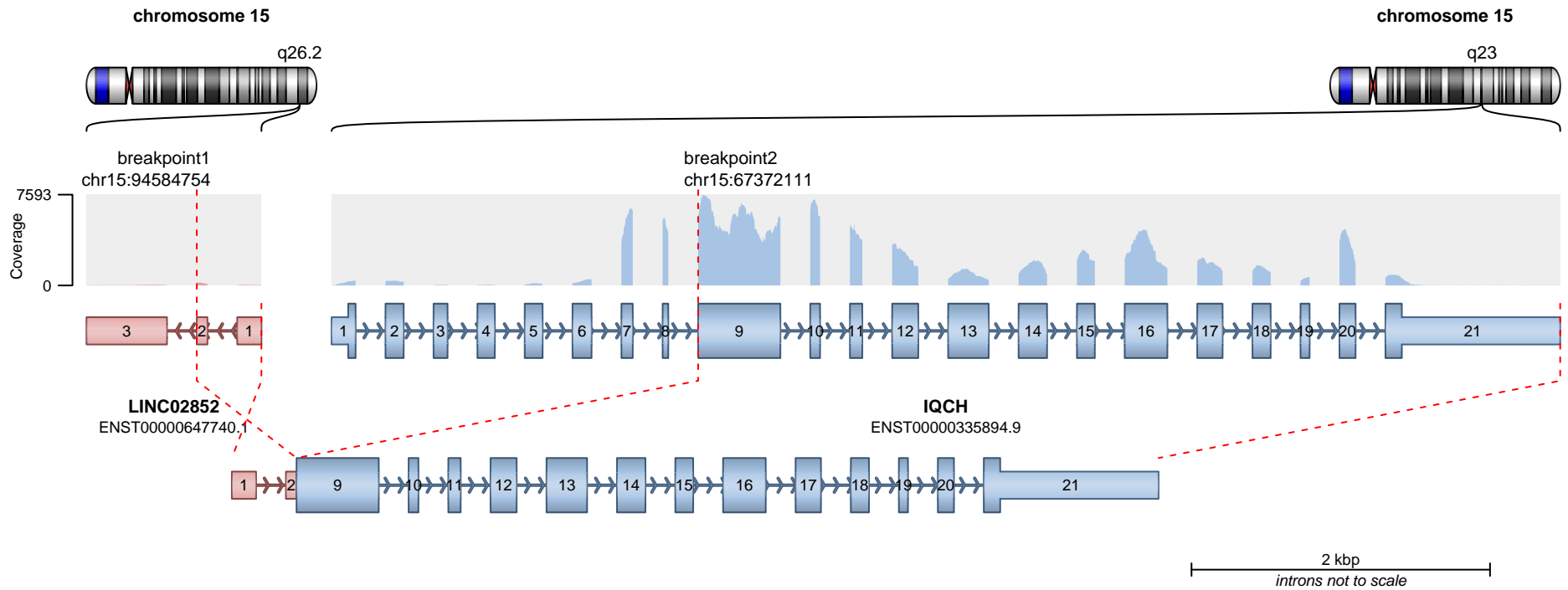

No protein domains retained in fusion.

**SUPPORTING READ COUNT**

Split reads = 8  
Discordant mates = 0

— translocation    — deletion  
— duplication    — inversion

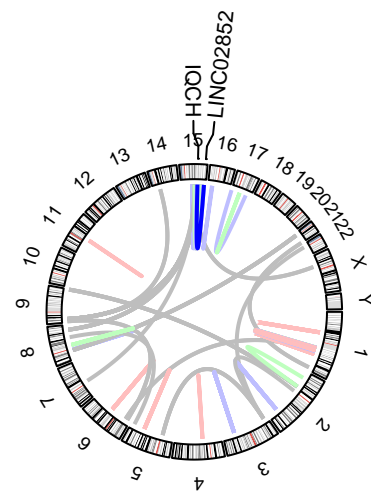
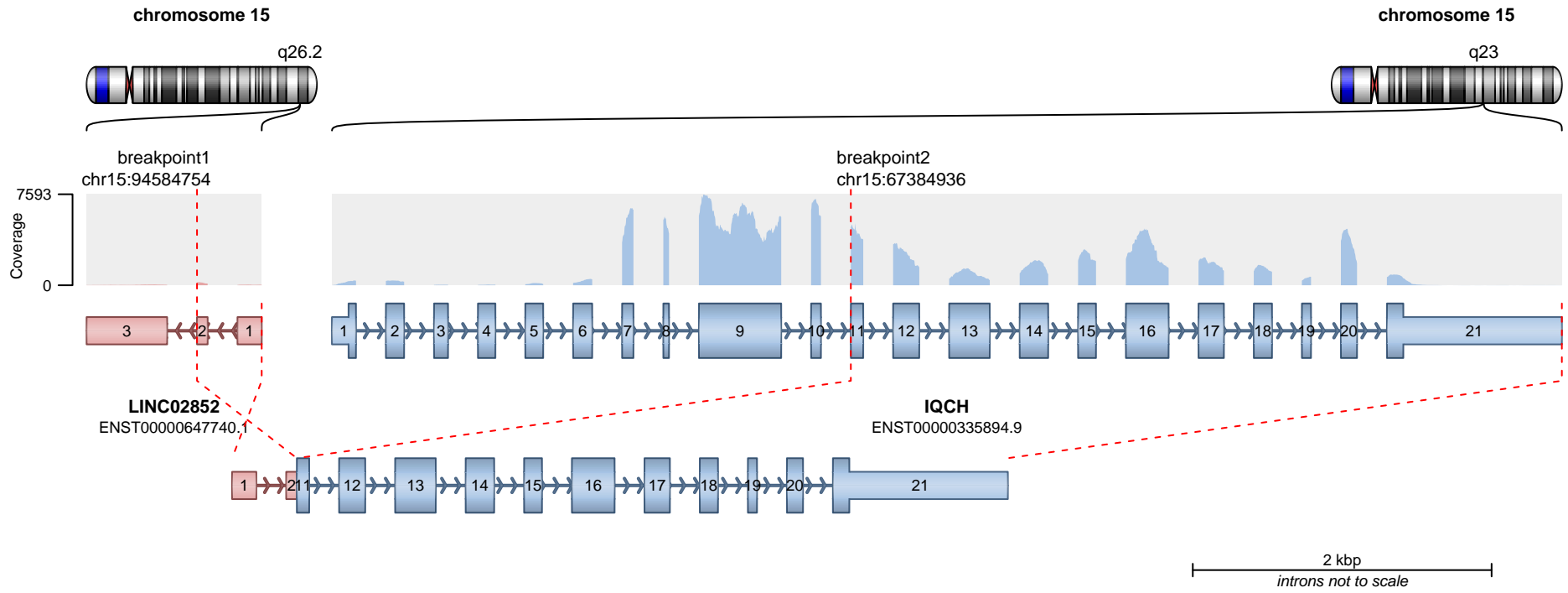

No protein domains retained in fusion.

**SUPPORTING READ COUNT**

Split reads = 1  
Discordant mates = 0

— translocation    — deletion  
— duplication    — inversion

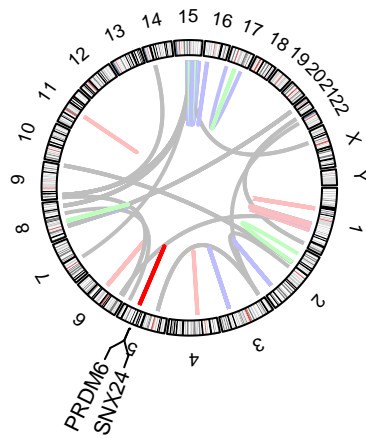
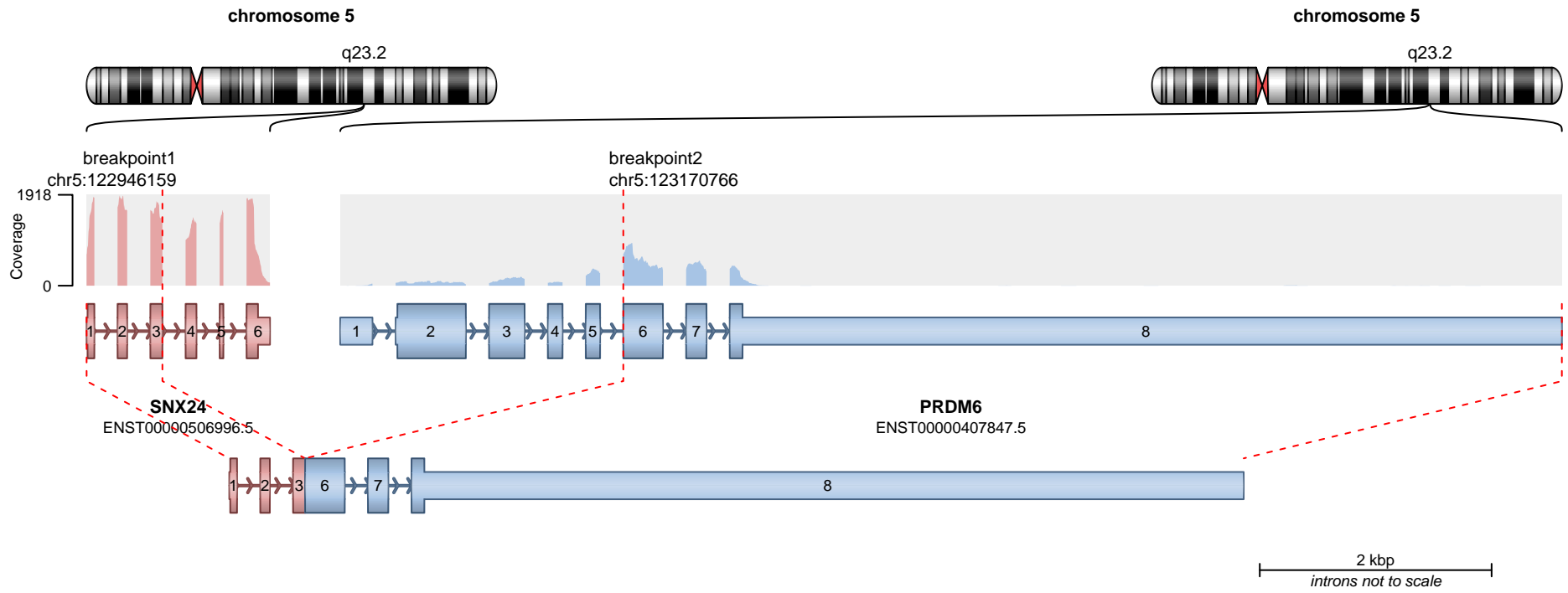

**RETAINED PROTEIN DOMAINS**  
reading frame unclear

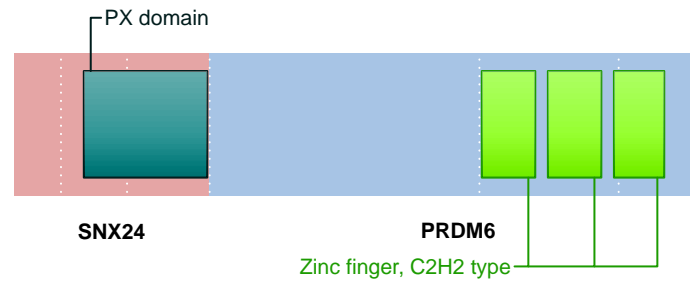

**SUPPORTING READ COUNT**

Split reads = 143  
Discordant mates = 1

— translocation — deletion  
— duplication — inversion

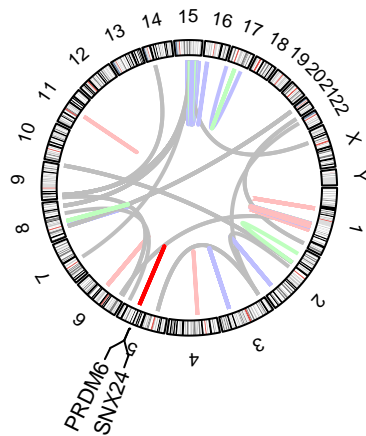
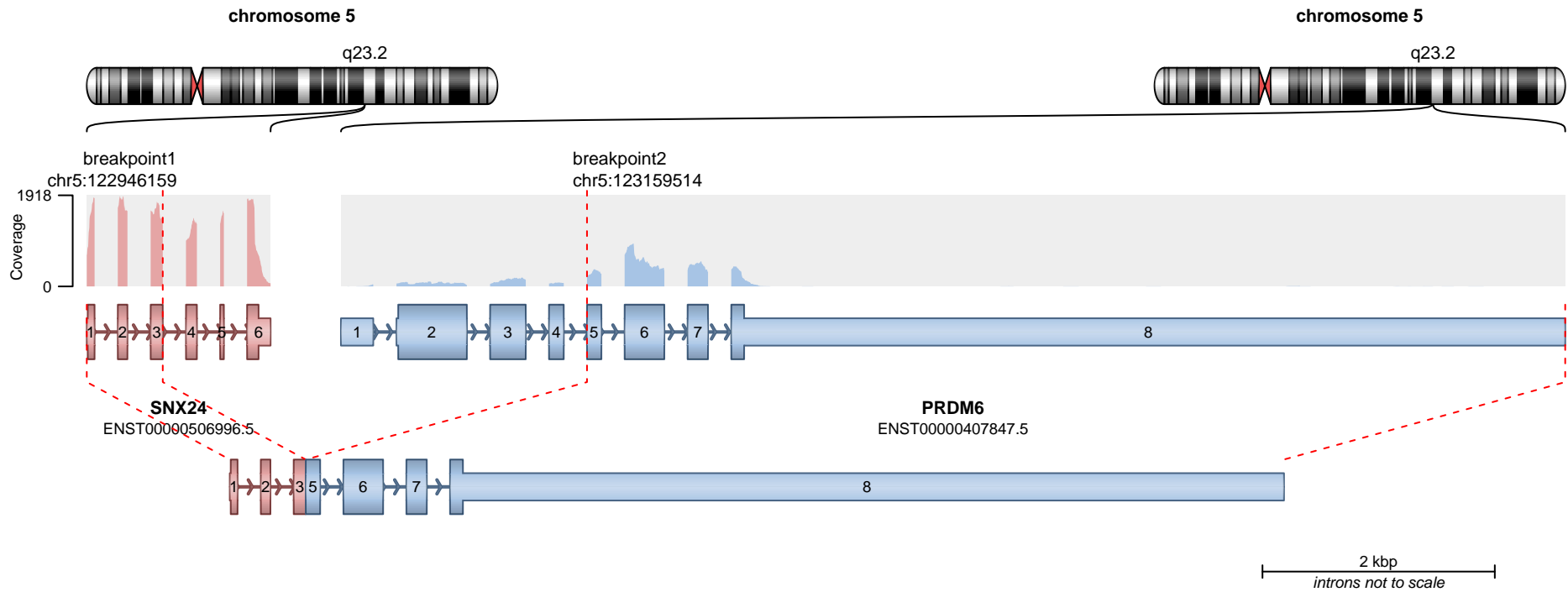

— translocation — deletion  
— duplication — inversion

**RETAINED PROTEIN DOMAINS**  
reading frame unclear

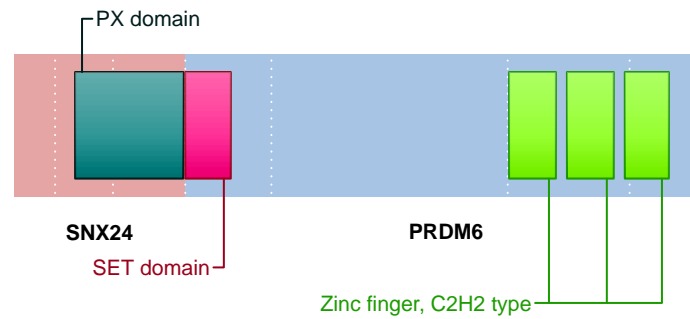

**SUPPORTING READ COUNT**

Split reads = 55  
Discordant mates = 1

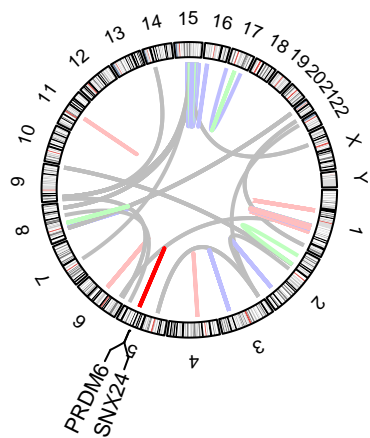
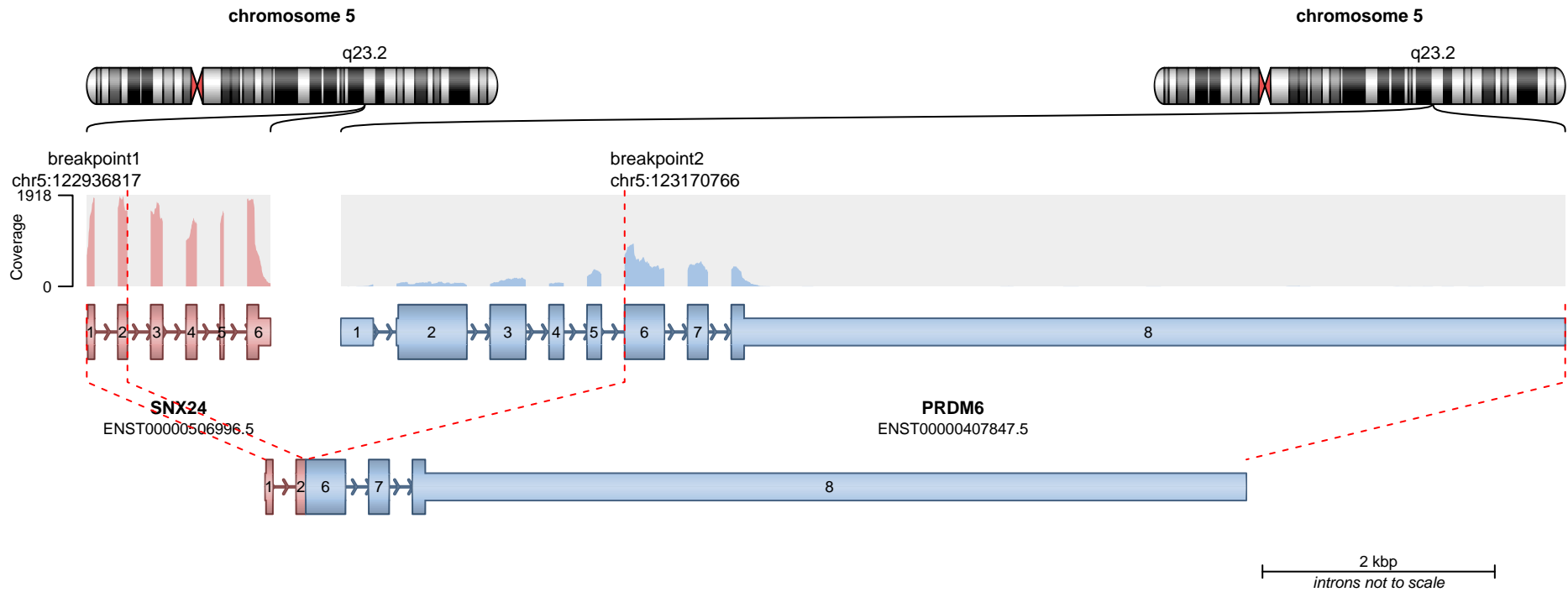

**RETAINED PROTEIN DOMAINS**  
reading frame unclear

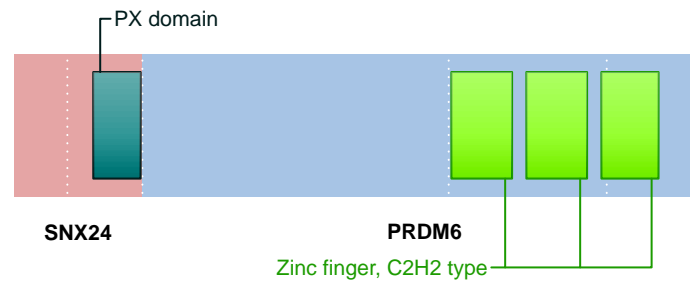

**SUPPORTING READ COUNT**

Split reads = 2  
Discordant mates = 0

- translocation
- duplication
- deletion
- inversion

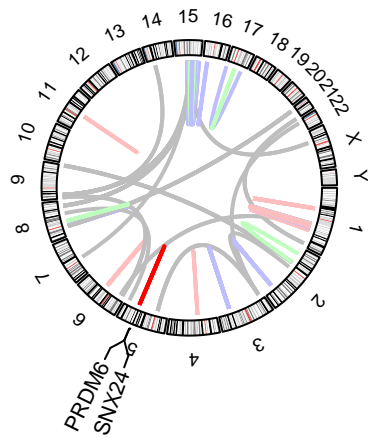
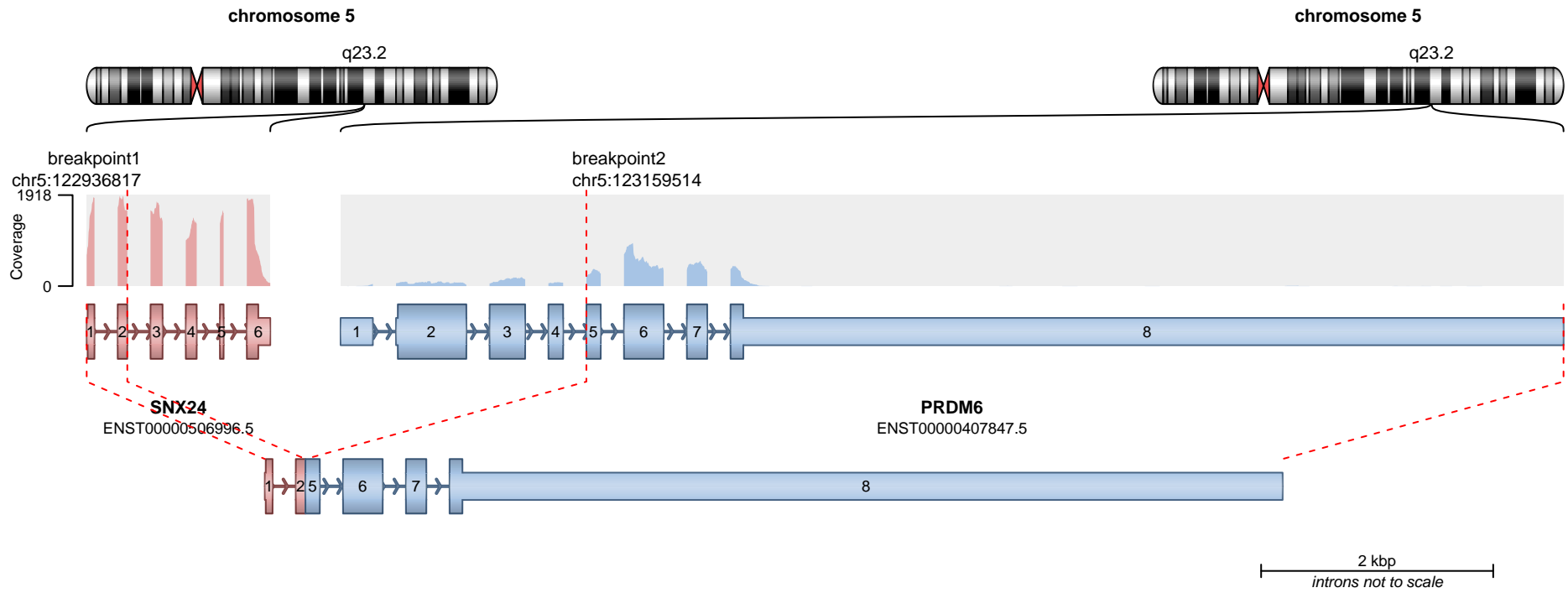

— translocation — deletion  
— duplication — inversion

**RETAINED PROTEIN DOMAINS**  
reading frame unclear

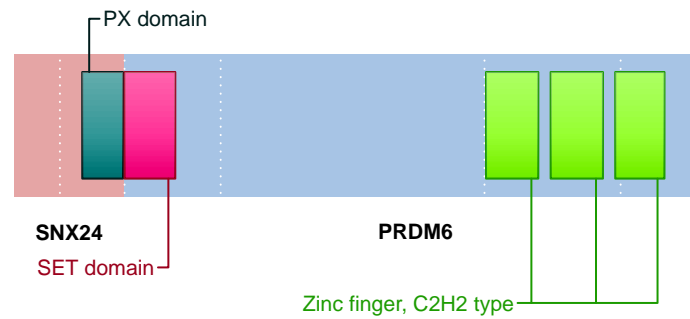

**SUPPORTING READ COUNT**

Split reads = 1  
Discordant mates = 0

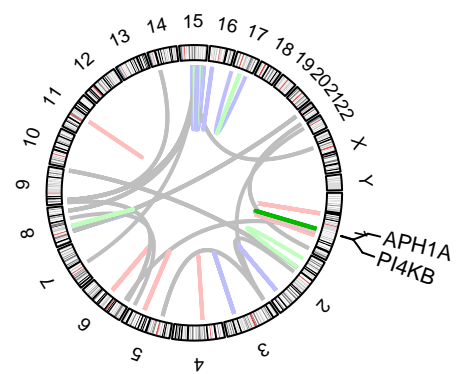
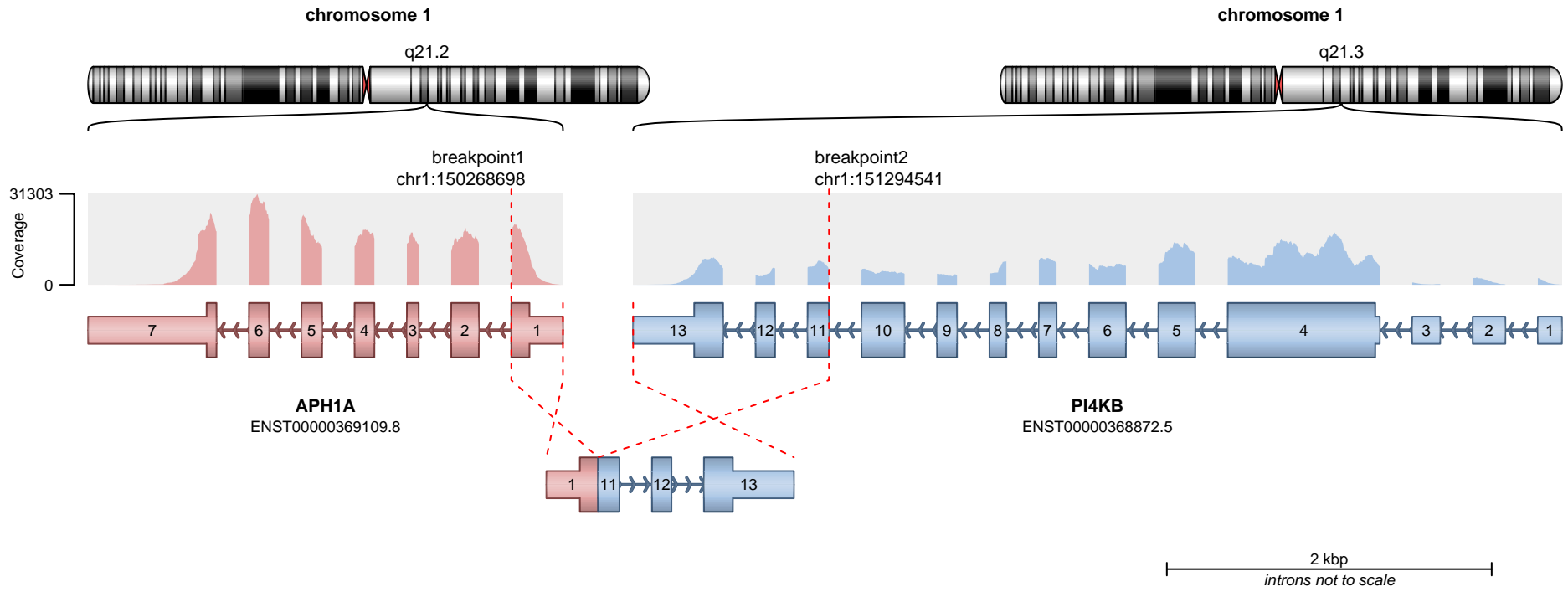

**RETAINED PROTEIN DOMAINS**  
reading frame unclear

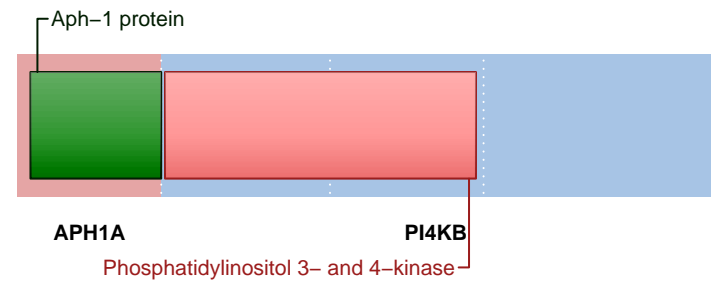

**SUPPORTING READ COUNT**

Split reads = 125  
Discordant mates = 0

- translocation
- duplication
- deletion
- inversion

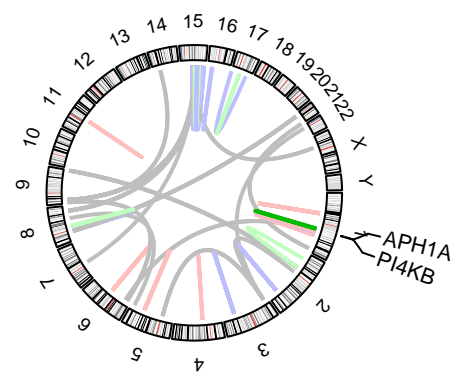
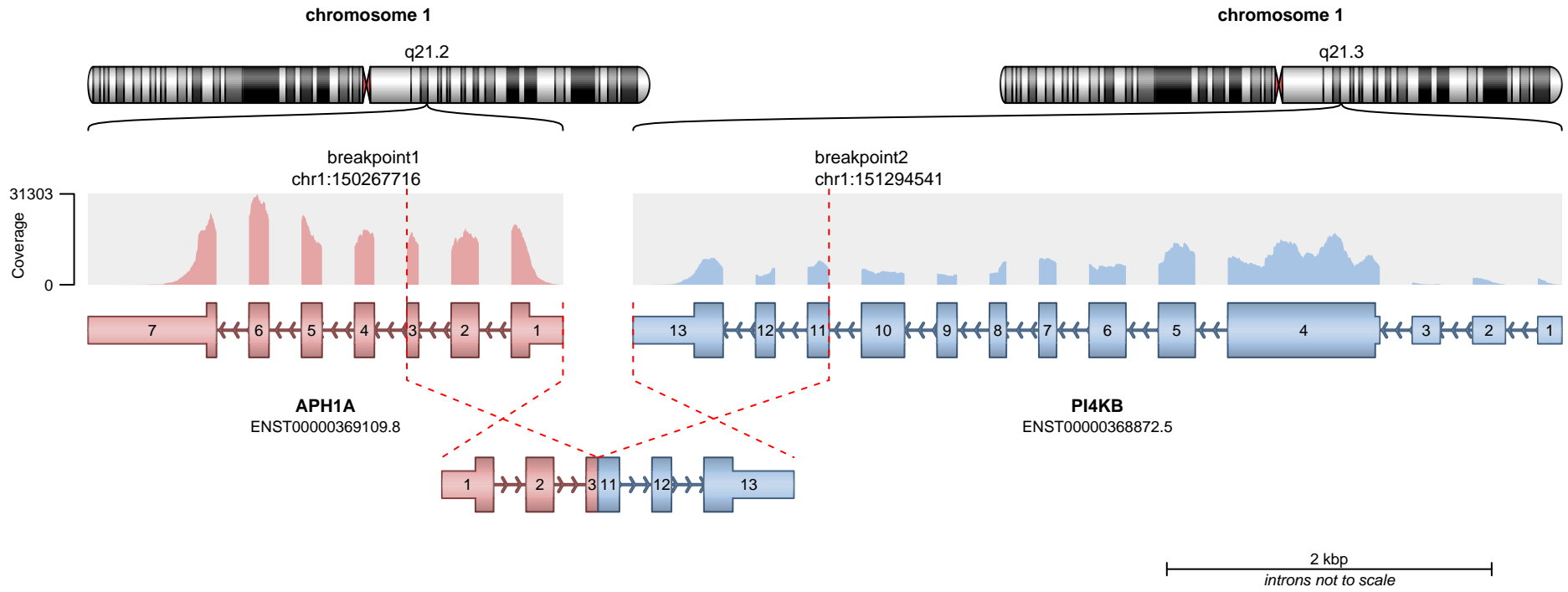

**RETAINED PROTEIN DOMAINS**  
reading frame unclear

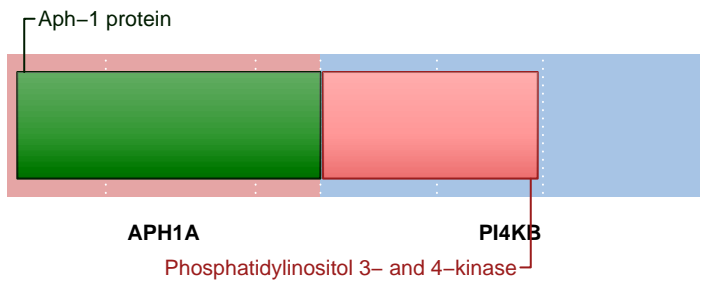

**SUPPORTING READ COUNT**

Split reads = 18  
Discordant mates = 1

- translocation
- duplication
- deletion
- inversion

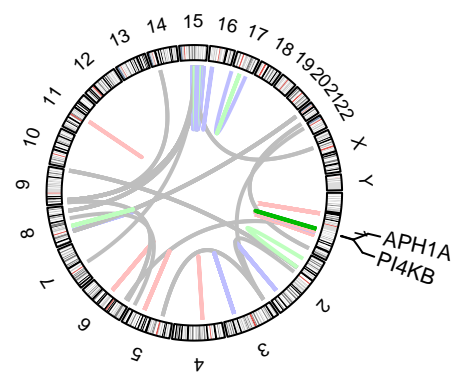
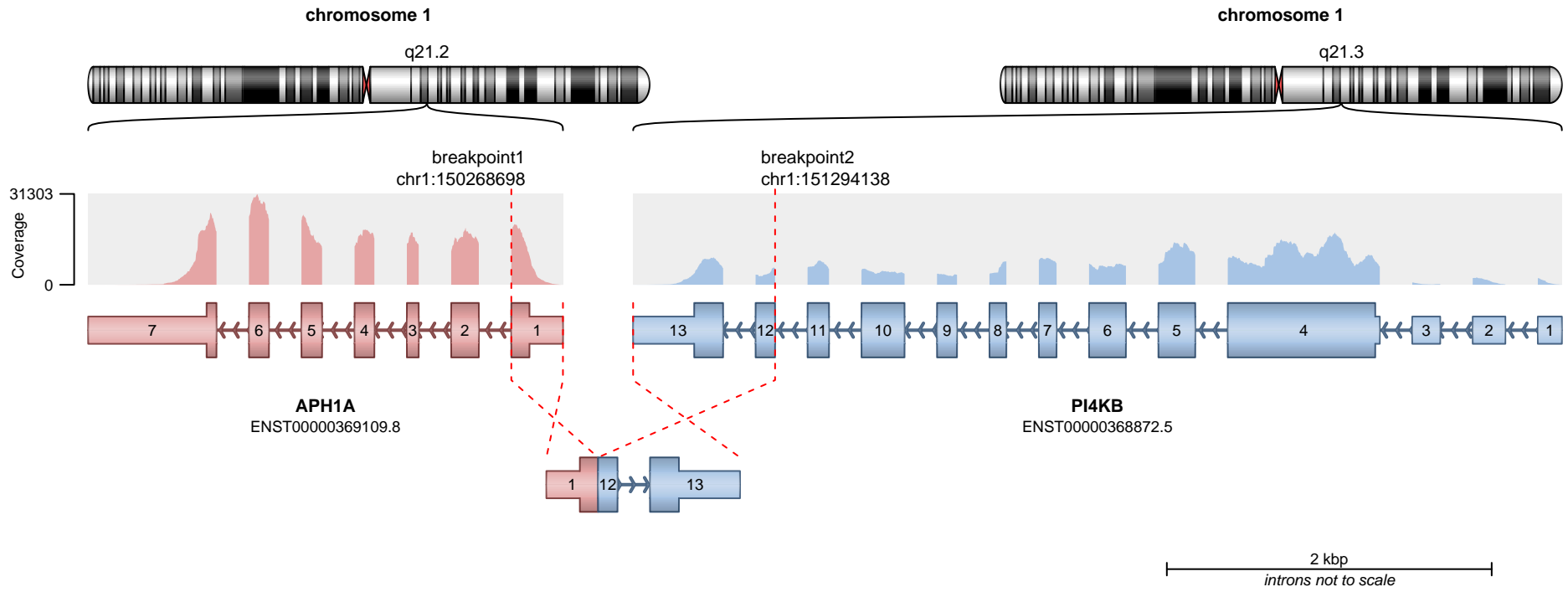

**RETAINED PROTEIN DOMAINS**  
reading frame unclear

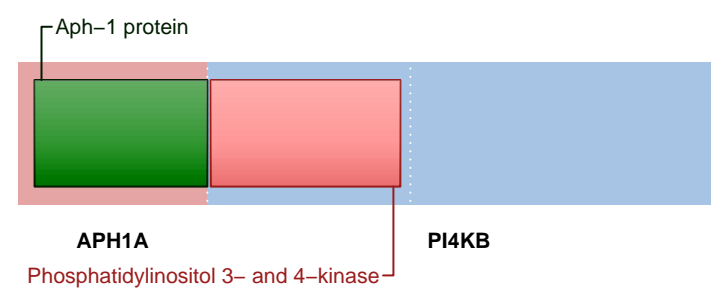

**SUPPORTING READ COUNT**

Split reads = 11  
Discordant mates = 0

- translocation
- duplication
- deletion
- inversion

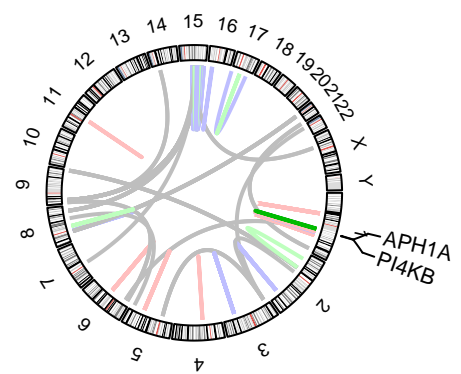
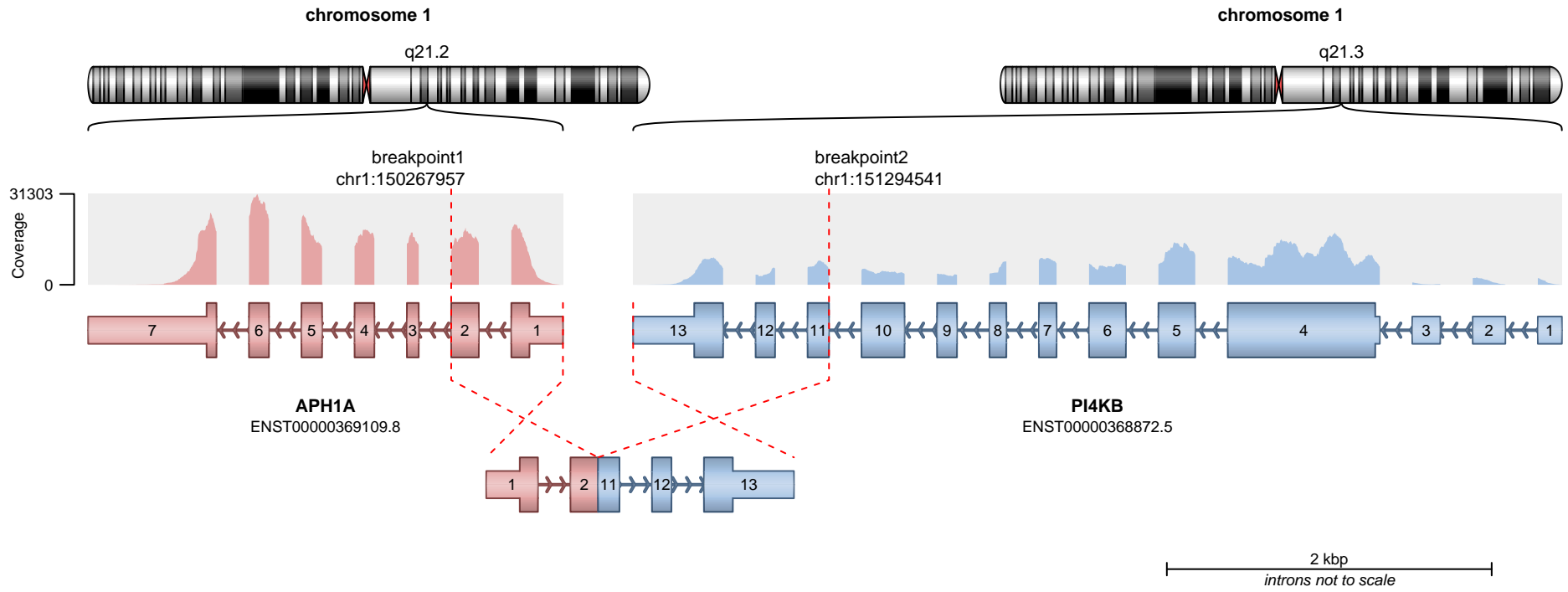

**RETAINED PROTEIN DOMAINS**  
reading frame unclear

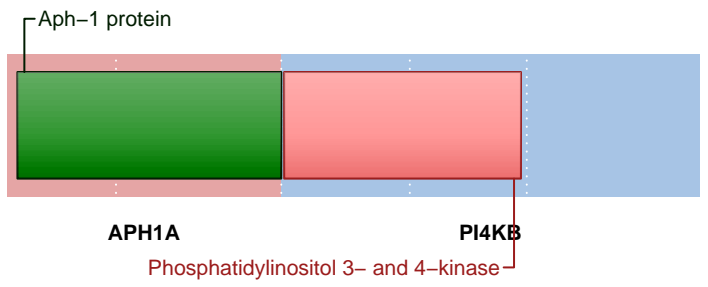

**SUPPORTING READ COUNT**

Split reads = 2  
Discordant mates = 1

- translocation
- duplication
- deletion
- inversion

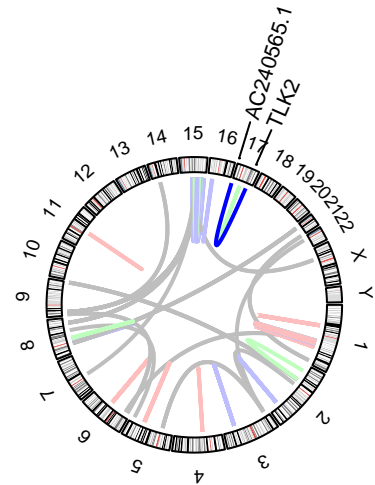
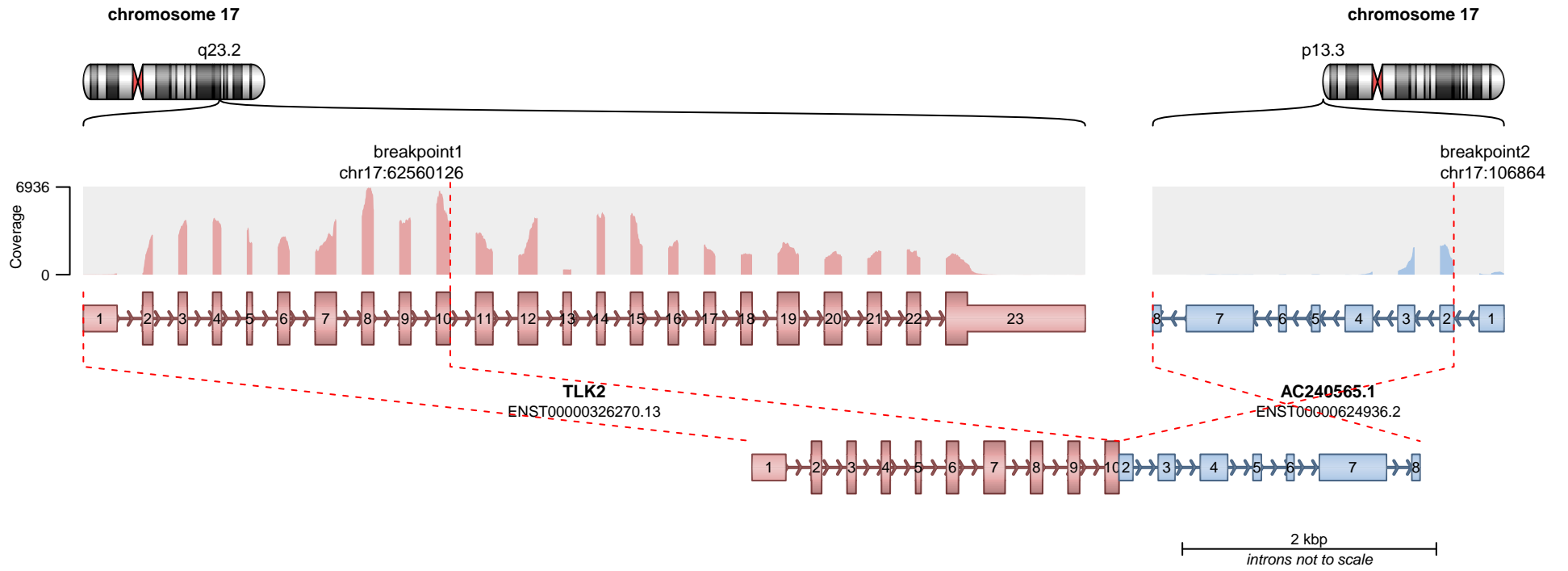

No protein domains retained in fusion.

**SUPPORTING READ COUNT**

Split reads = 124  
Discordant mates = 0

— translocation    — deletion  
— duplication    — inversion

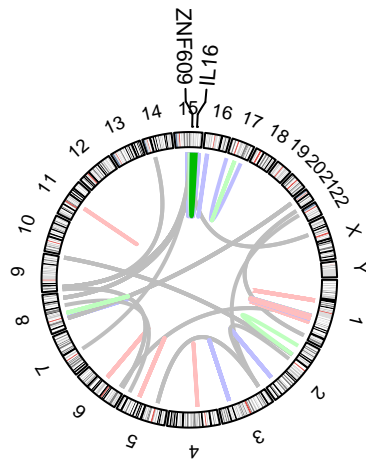
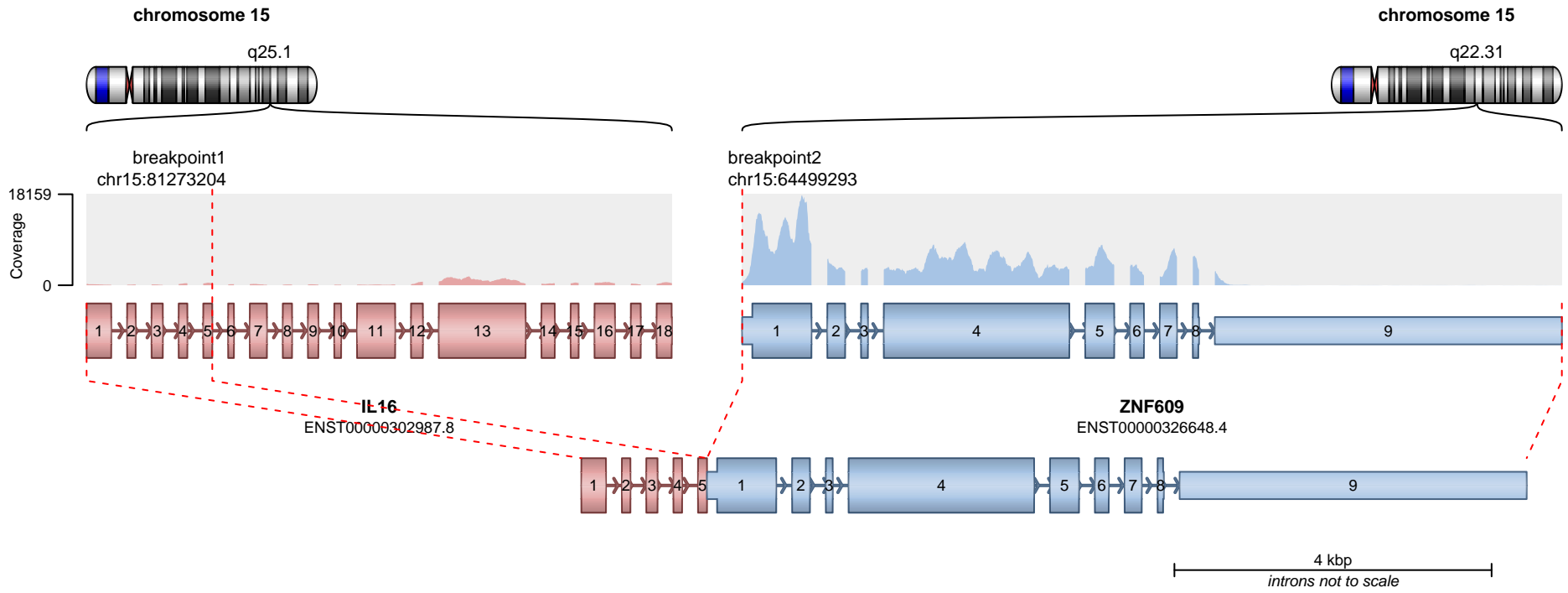

**RETAINED PROTEIN DOMAINS**  
reading frame unclear

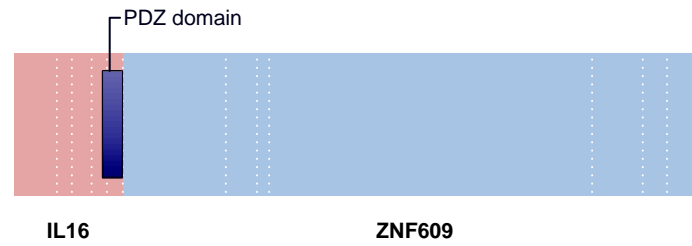

**SUPPORTING READ COUNT**

Split reads = 109  
Discordant mates = 1

- translocation
- duplication
- deletion
- inversion

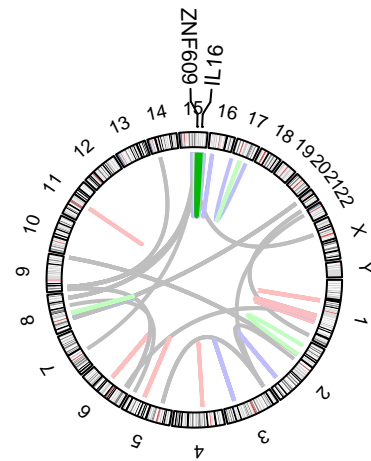
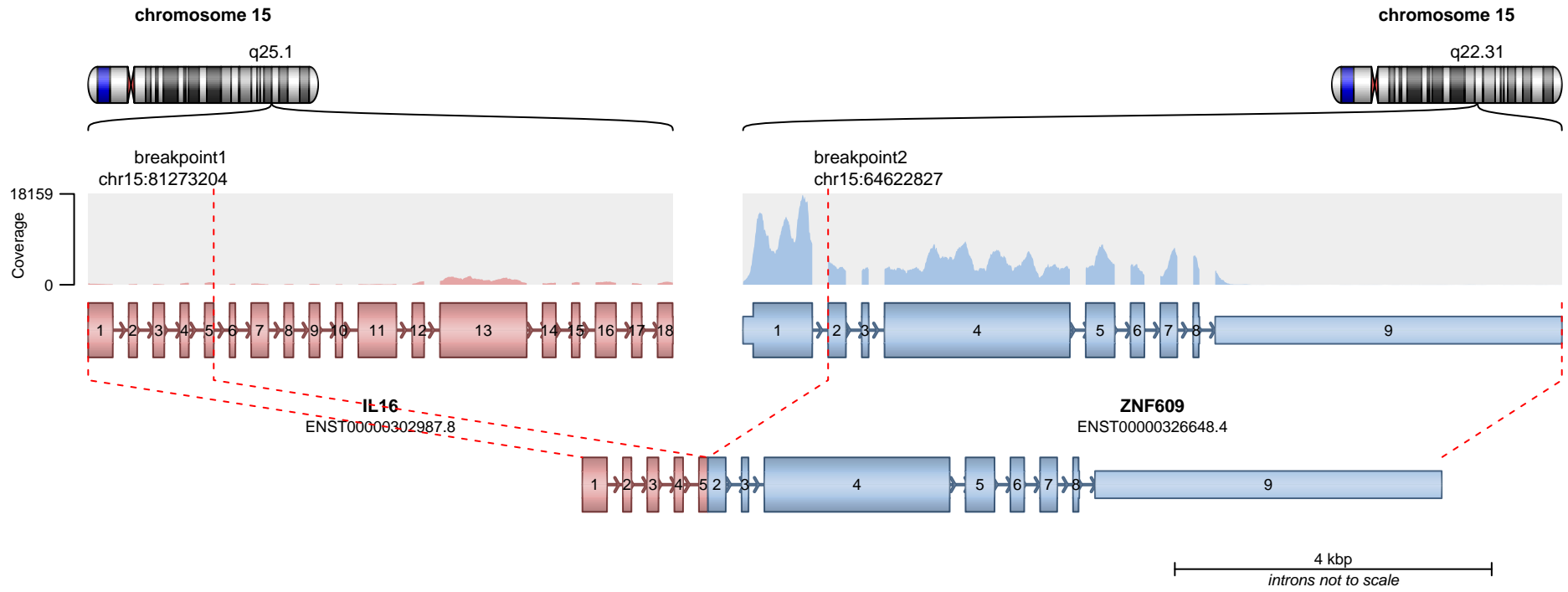

**RETAINED PROTEIN DOMAINS**  
reading frame unclear

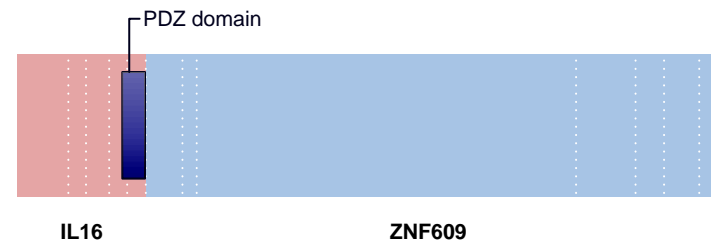

**SUPPORTING READ COUNT**

Split reads = 2  
Discordant mates = 0

- translocation
- duplication
- deletion
- inversion

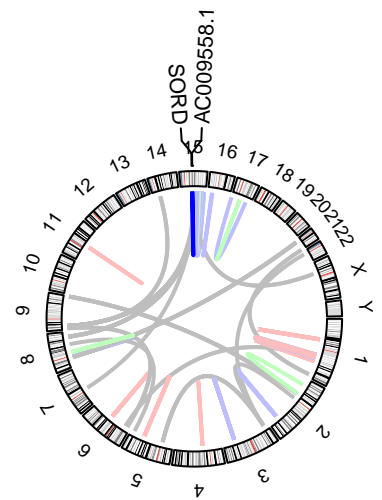
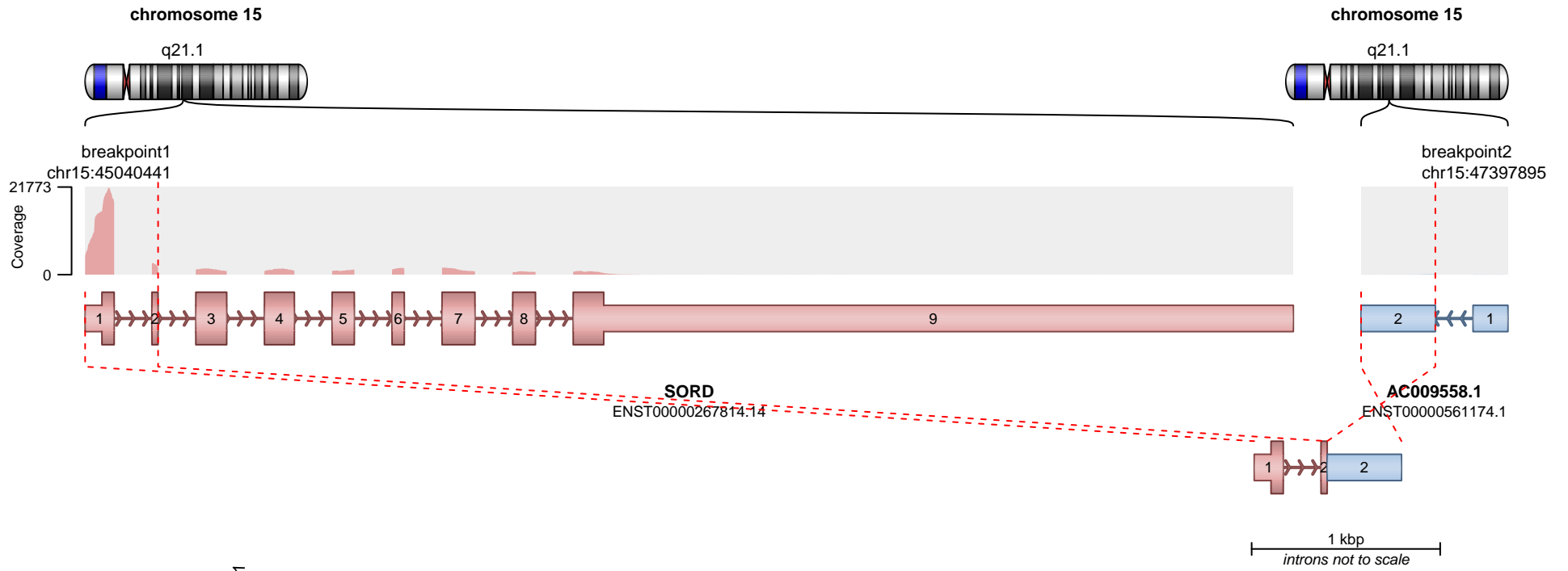

**RETAINED PROTEIN DOMAINS**  
reading frame unclear



**SUPPORTING READ COUNT**

Split reads = 96  
Discordant mates = 1

**SORD**

- translocation
- duplication
- deletion
- inversion

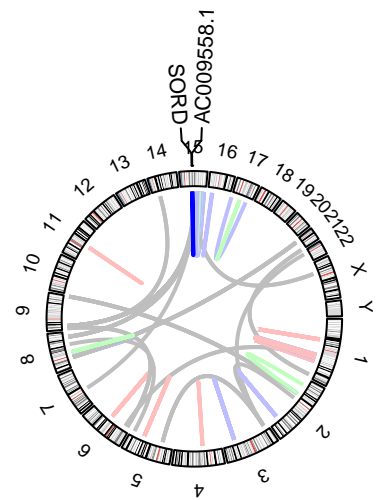
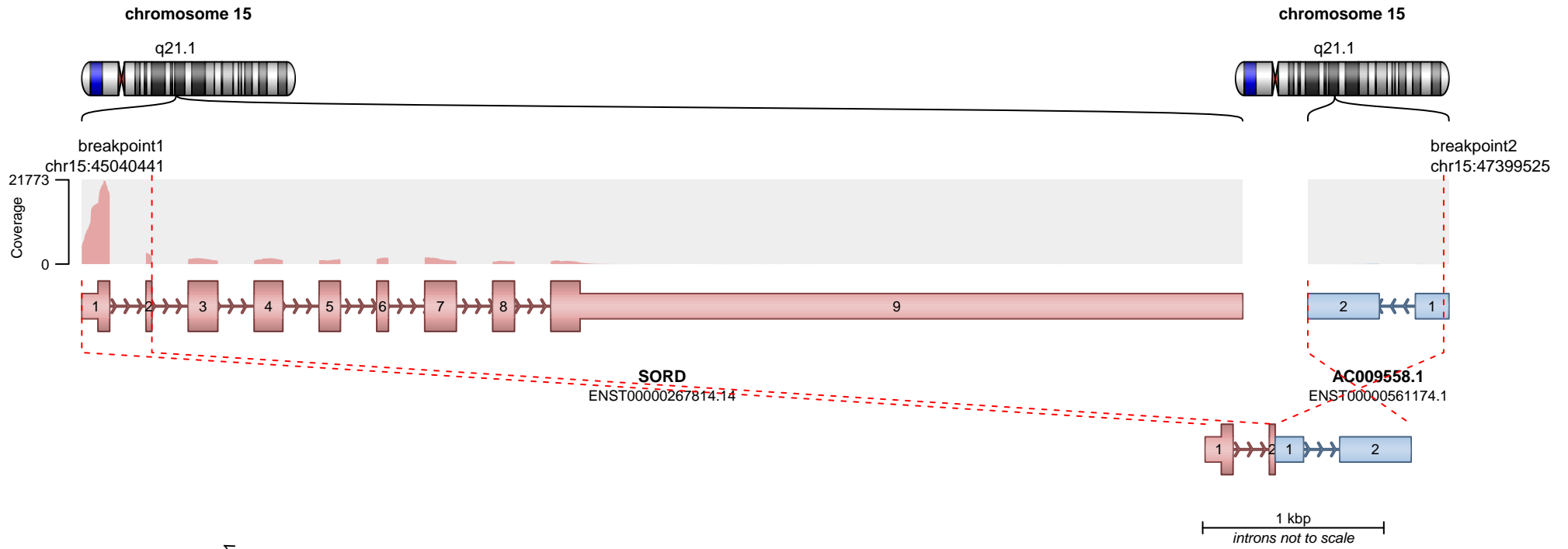

**RETAINED PROTEIN DOMAINS**  
reading frame unclear



**SUPPORTING READ COUNT**

Split reads = 8  
Discordant mates = 2

— translocation    — deletion  
— duplication    — inversion

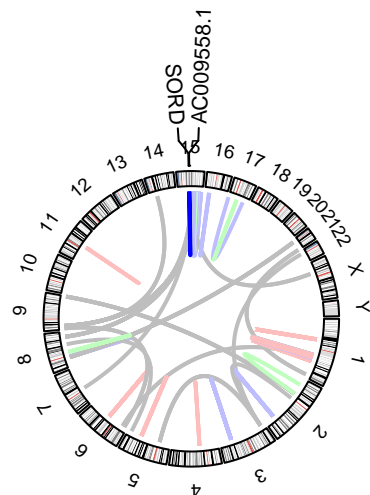
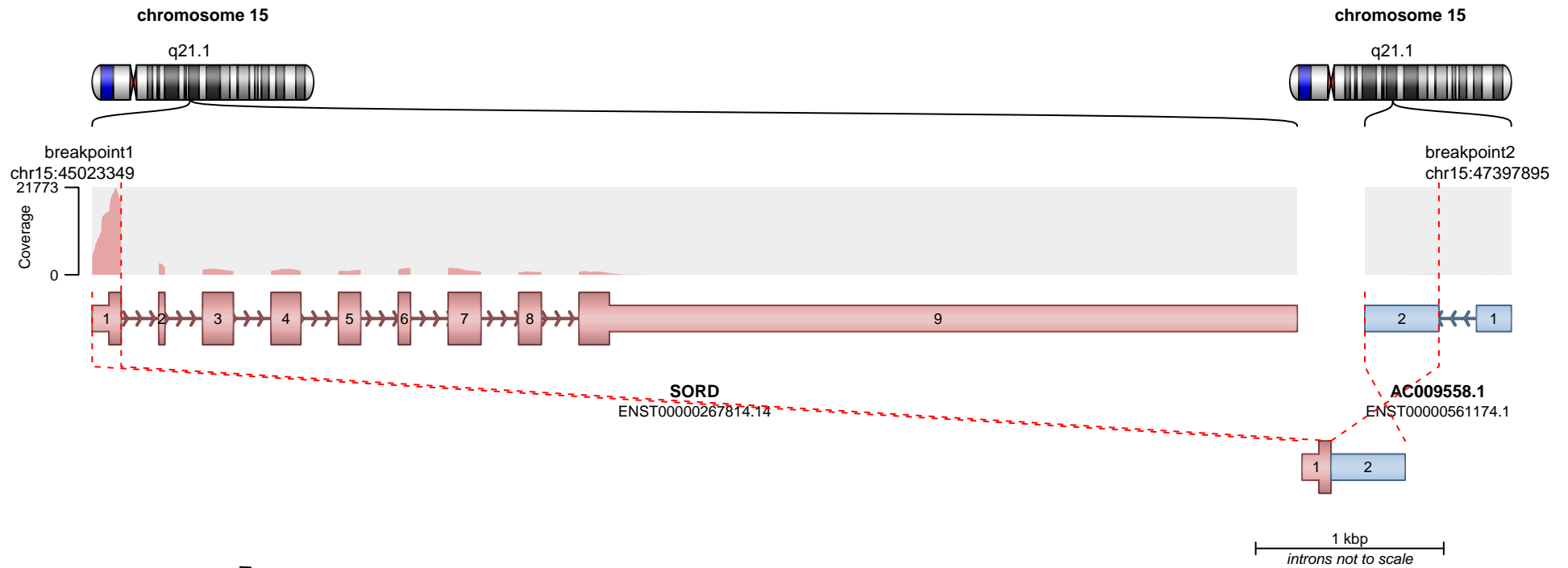

— translocation    — deletion  
— duplication    — inversion

No protein domains retained in fusion.

**SUPPORTING READ COUNT**

Split reads = 1  
Discordant mates = 1

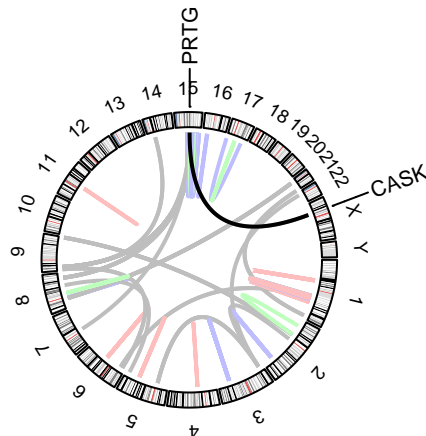
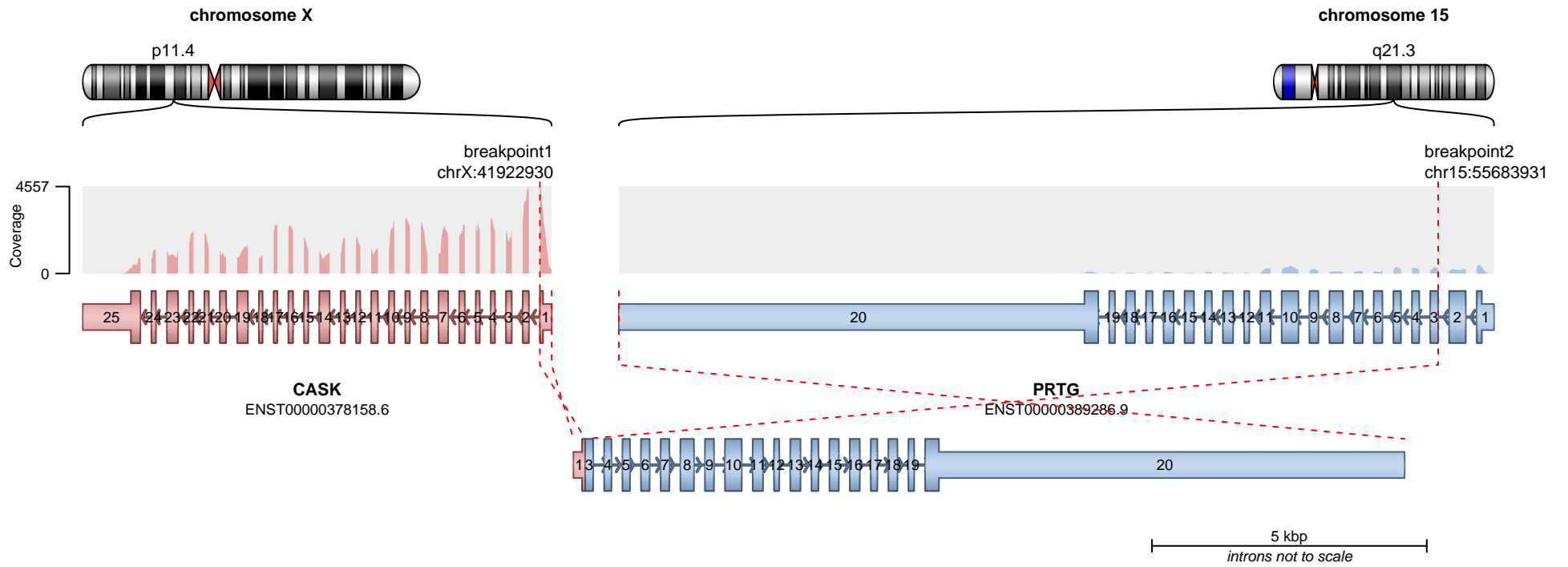

**RETAINED PROTEIN DOMAINS**  
reading frame unclear

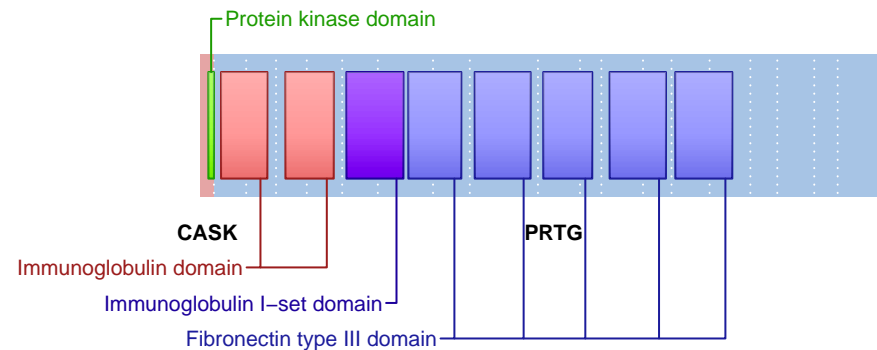

**SUPPORTING READ COUNT**

Split reads = 94  
Discordant mates = 3

- translocation
- duplication
- deletion
- inversion

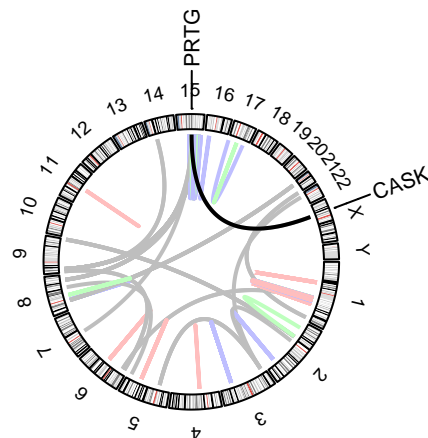
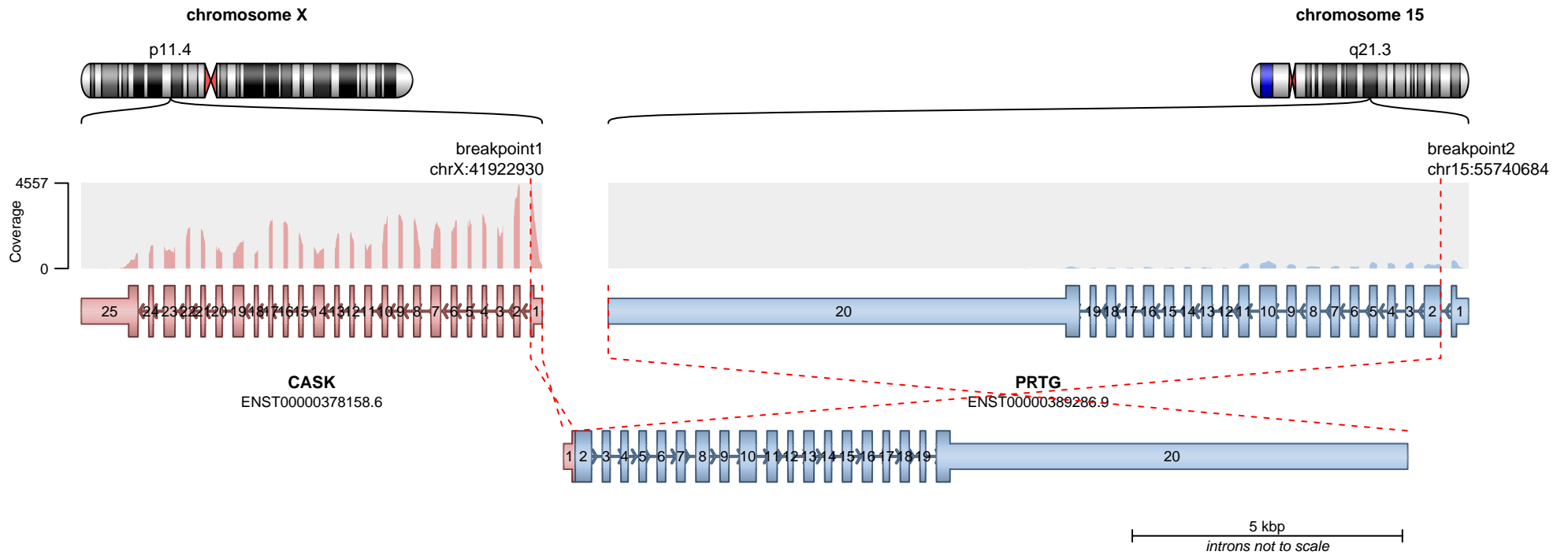

— translocation — deletion  
— duplication — inversion

**RETAINED PROTEIN DOMAINS**  
reading frame unclear

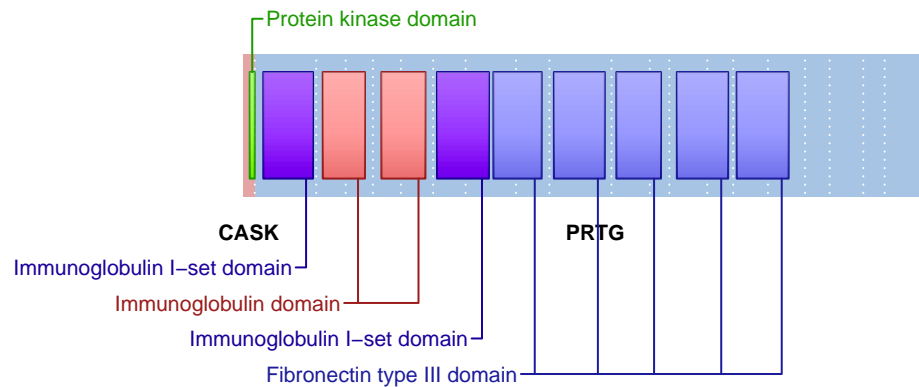

**SUPPORTING READ COUNT**

Split reads = 15  
Discordant mates = 3

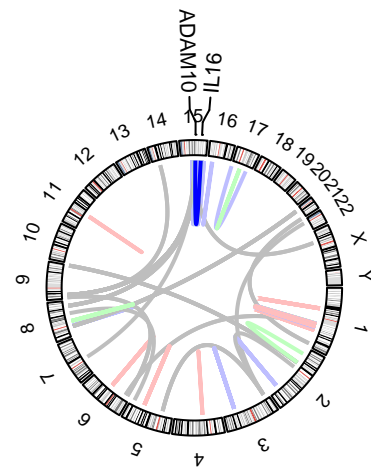
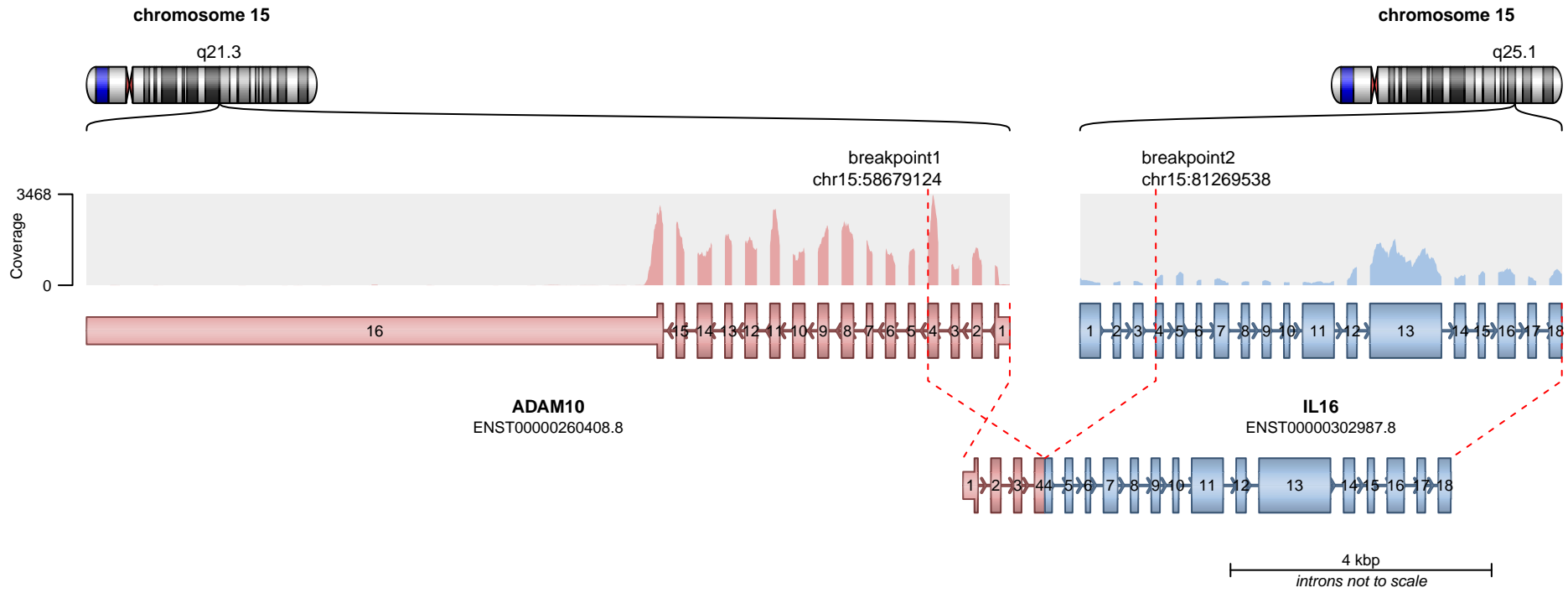

**RETAINED PROTEIN DOMAINS**  
reading frame unclear

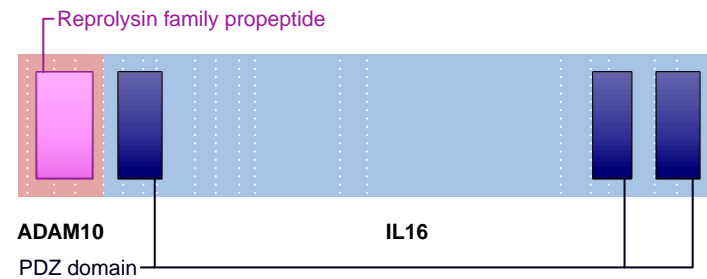

**SUPPORTING READ COUNT**

Split reads = 87  
Discordant mates = 0

- translocation
- duplication
- deletion
- inversion

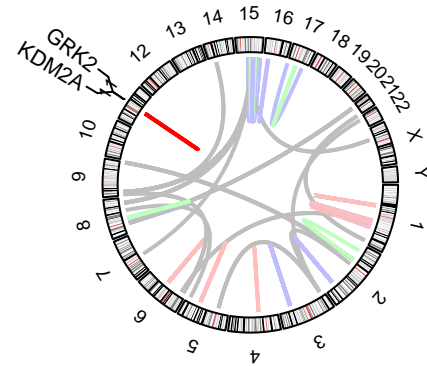
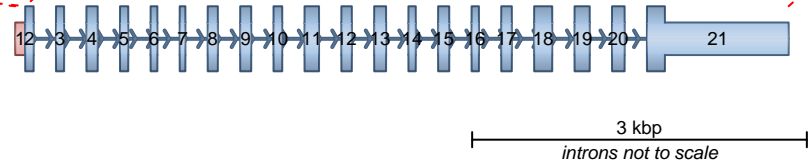
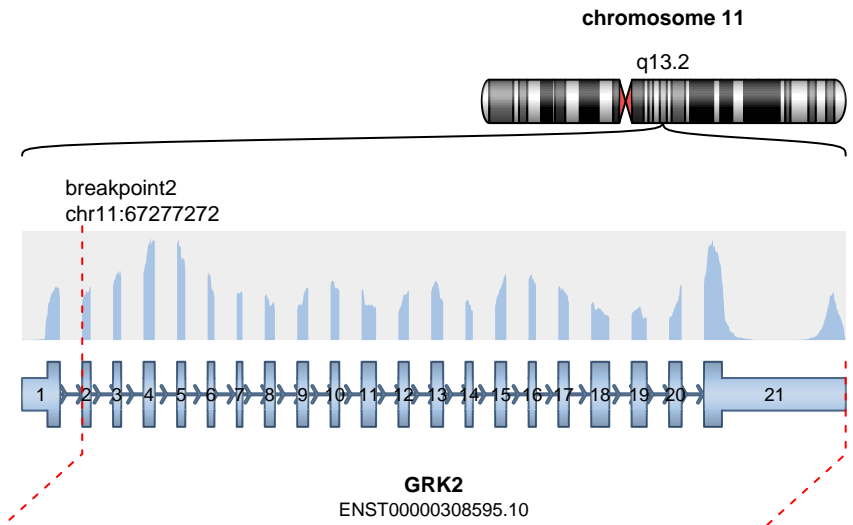
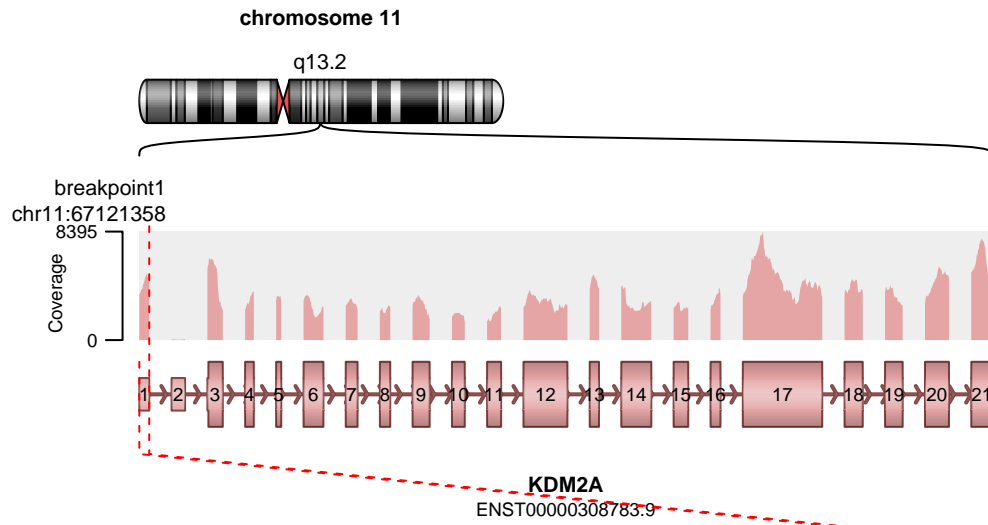

— translocation — deletion  
— duplication — inversion

**RETAINED PROTEIN DOMAINS**  
reading frame unclear

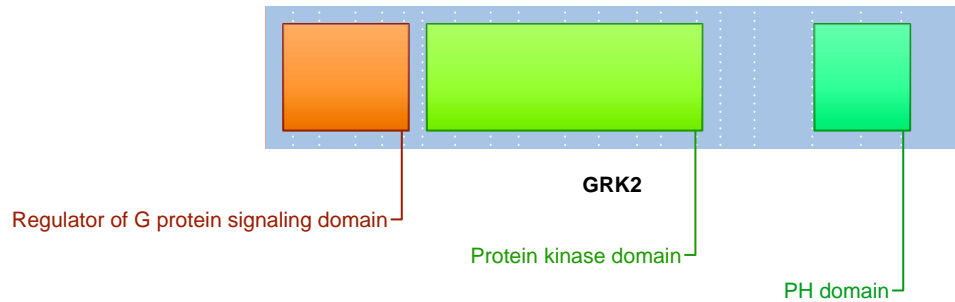

**SUPPORTING READ COUNT**

Split reads = 86  
Discordant mates = 3

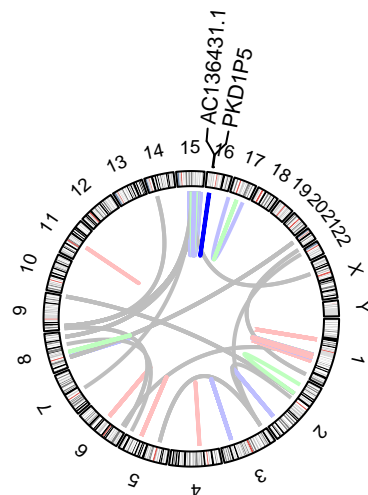
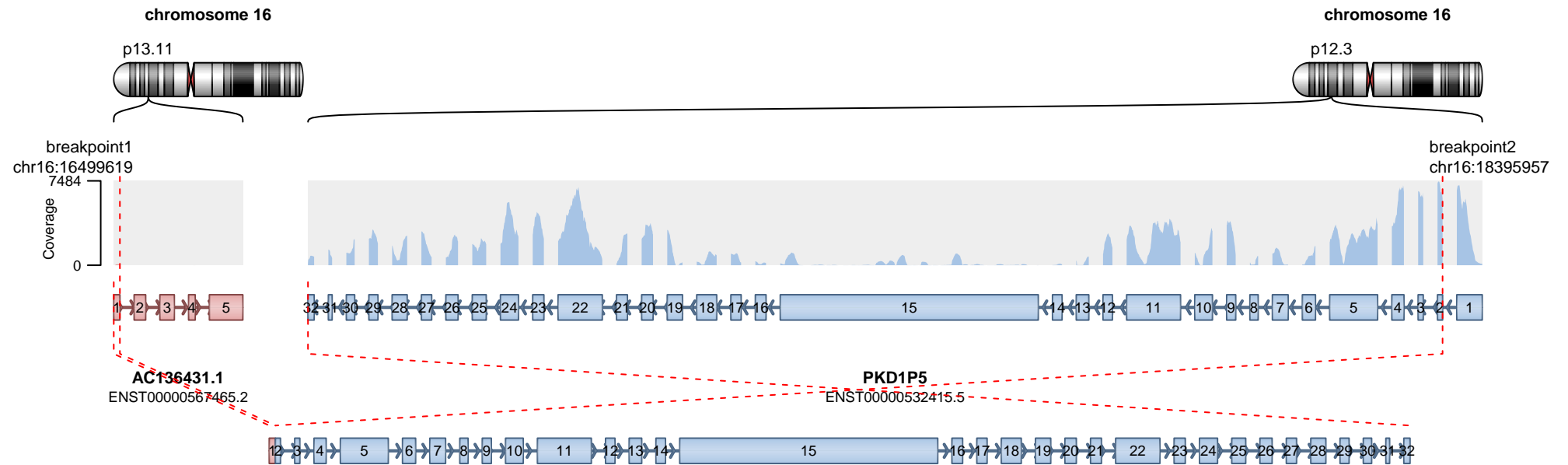

Genes are not protein-coding.

**SUPPORTING READ COUNT**

Split reads = 84  
Discordant mates = 0

— translocation — deletion  
— duplication — inversion

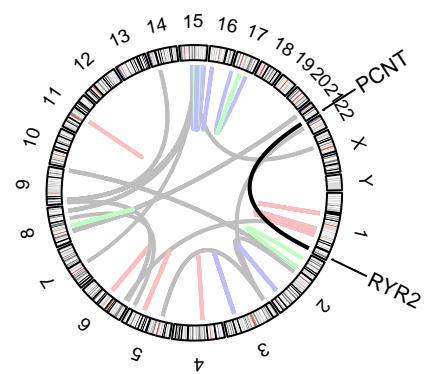
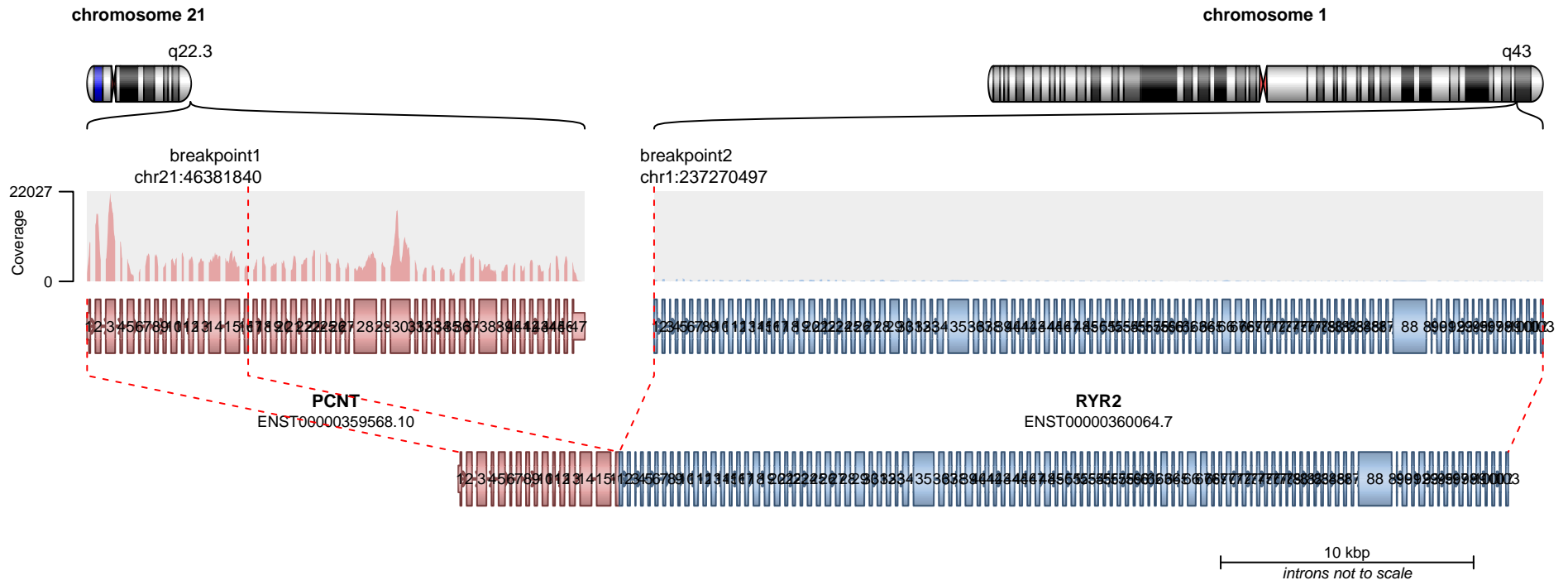

— translocation    — deletion  
 — duplication    — inversion

**RETAINED PROTEIN DOMAINS**  
reading frame unclear

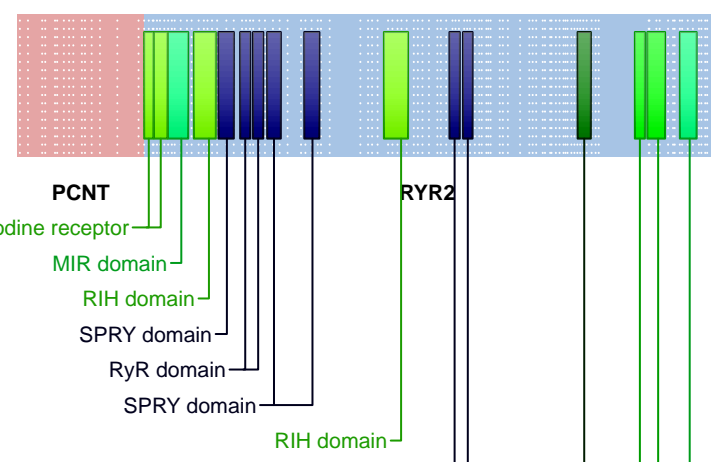

**SUPPORTING READ COUNT**

Split reads = 73  
 Discordant mates = 2

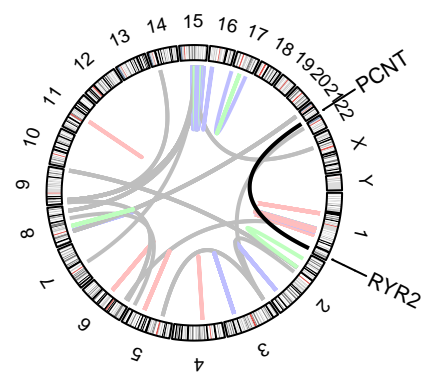
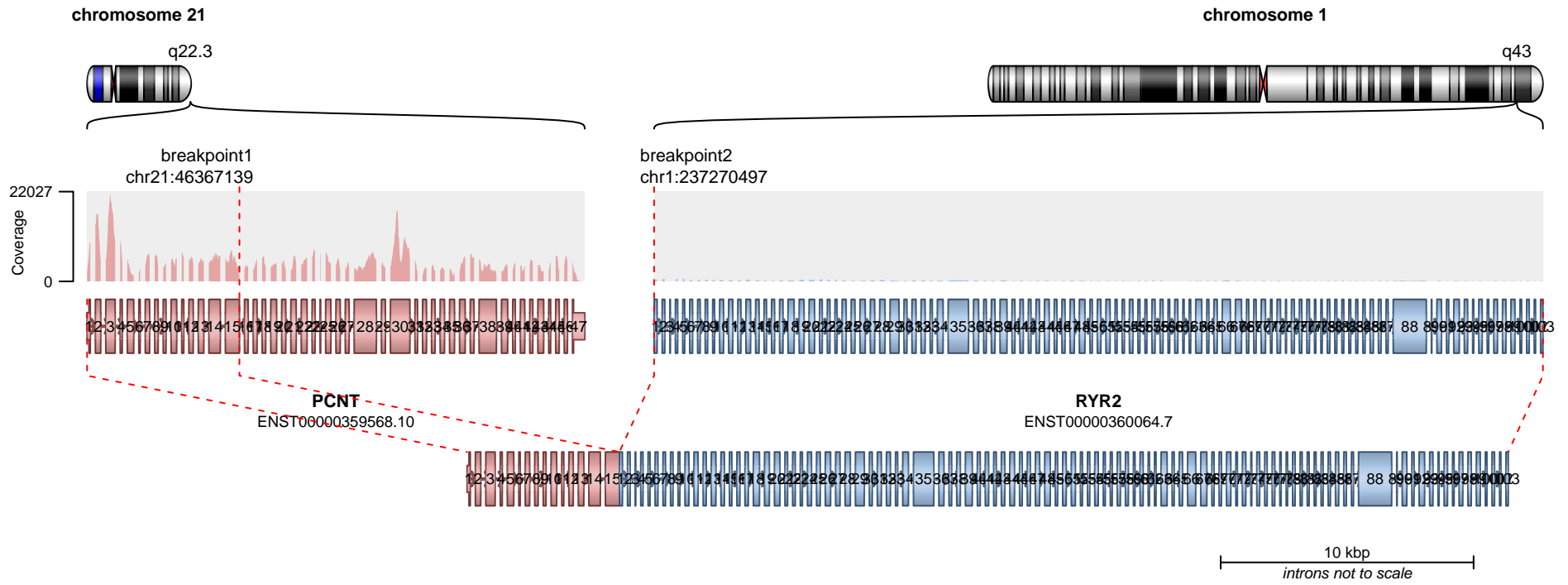

— translocation    — deletion  
— duplication    — inversion

**RETAINED PROTEIN DOMAINS**  
reading frame unclear

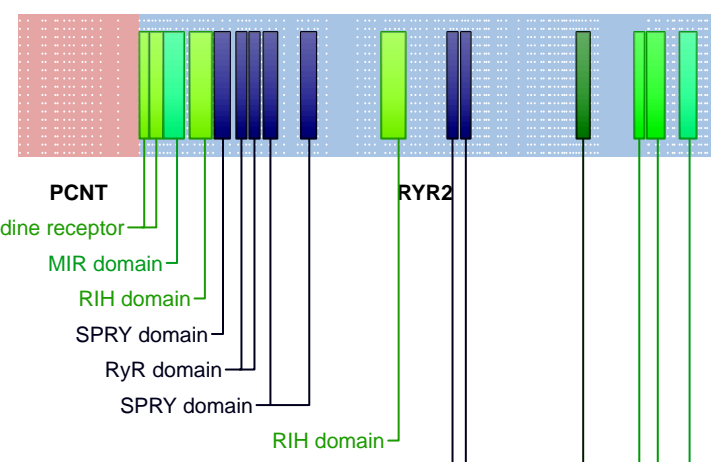

**SUPPORTING READ COUNT**

Split reads = 34  
Discordant mates = 0

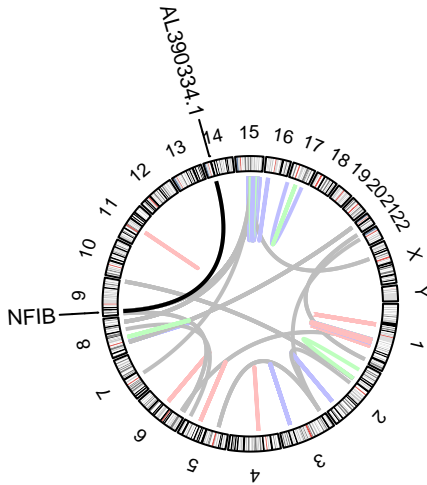
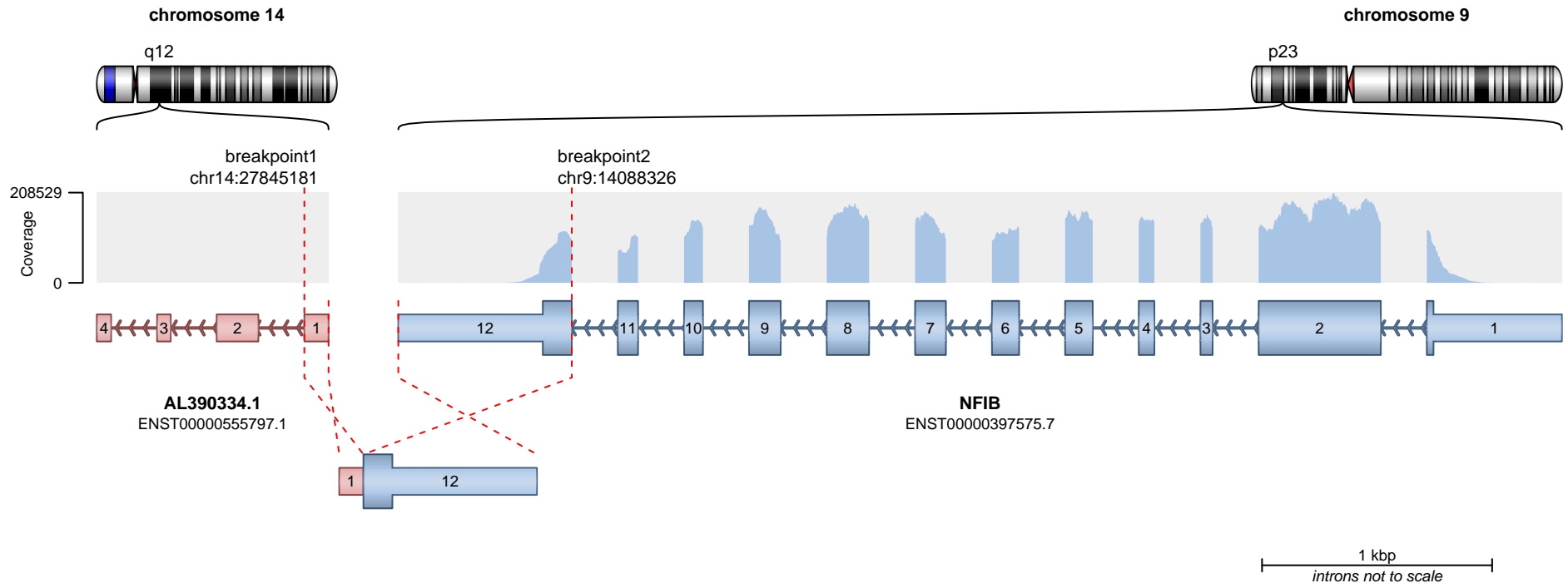

CTF/NF-I family transcription modulation region

**RETAINED PROTEIN DOMAINS**  
reading frame unclear



**SUPPORTING READ COUNT**

Split reads = 65  
Discordant mates = 0

- translocation
- duplication
- deletion
- inversion

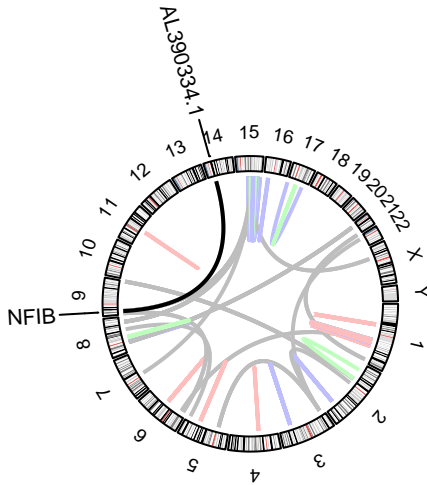
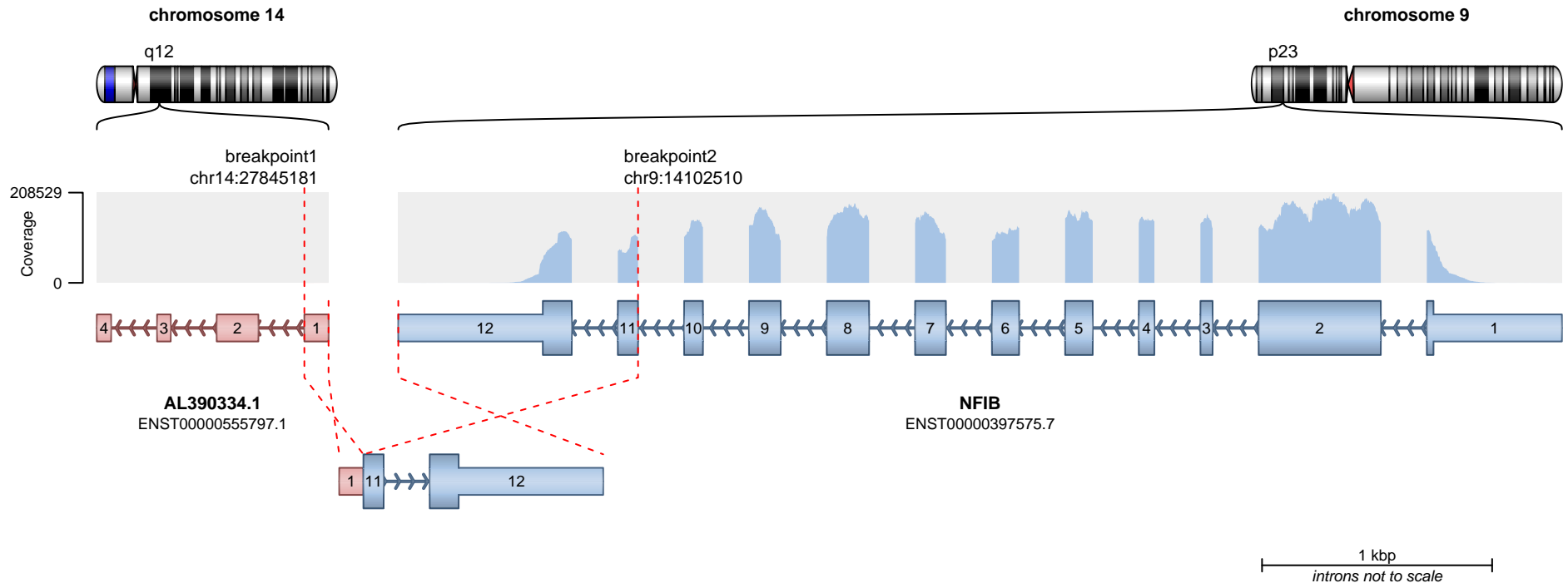

CTF/NF-I family transcription modulation region

**RETAINED PROTEIN DOMAINS**  
reading frame unclear

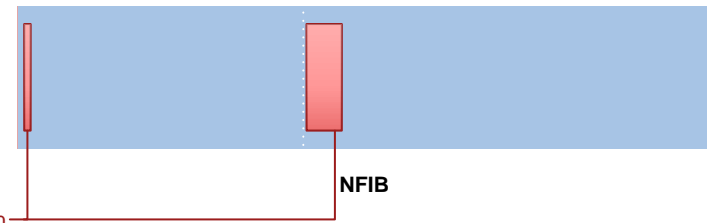

**SUPPORTING READ COUNT**

Split reads = 11  
Discordant mates = 0

- translocation
- duplication
- deletion
- inversion

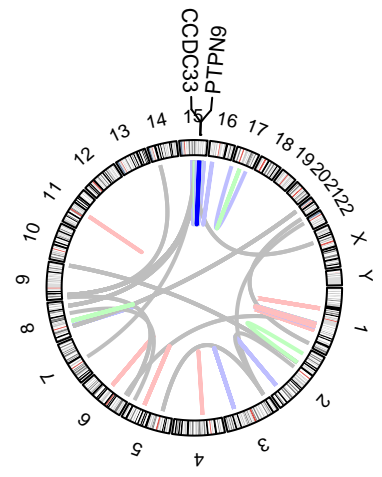
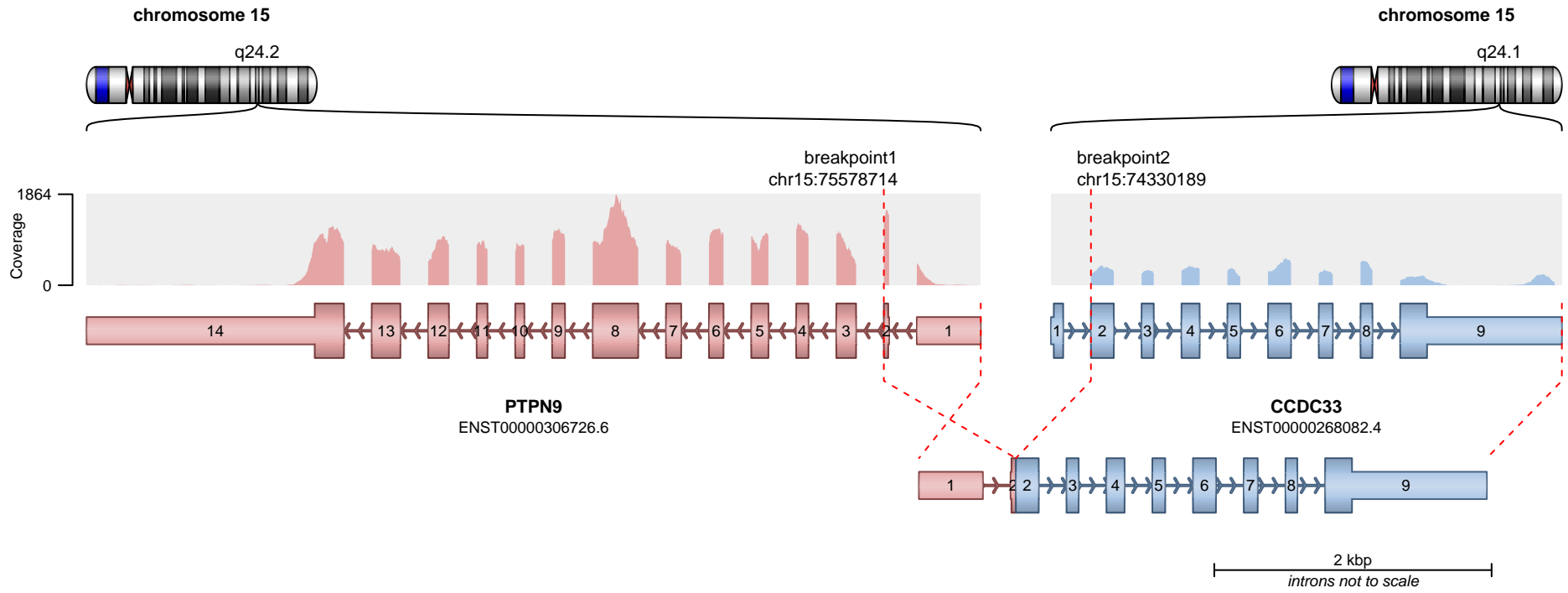

— translocation    — deletion  
— duplication    — inversion

No protein domains retained in fusion.

**SUPPORTING READ COUNT**

Split reads = 62  
Discordant mates = 0

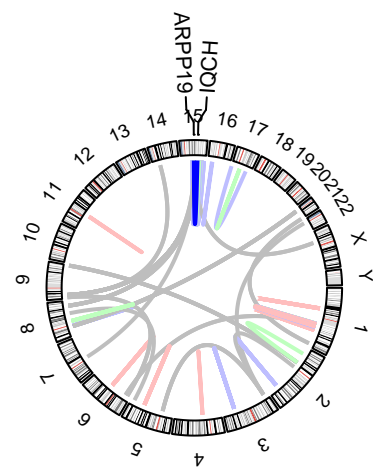
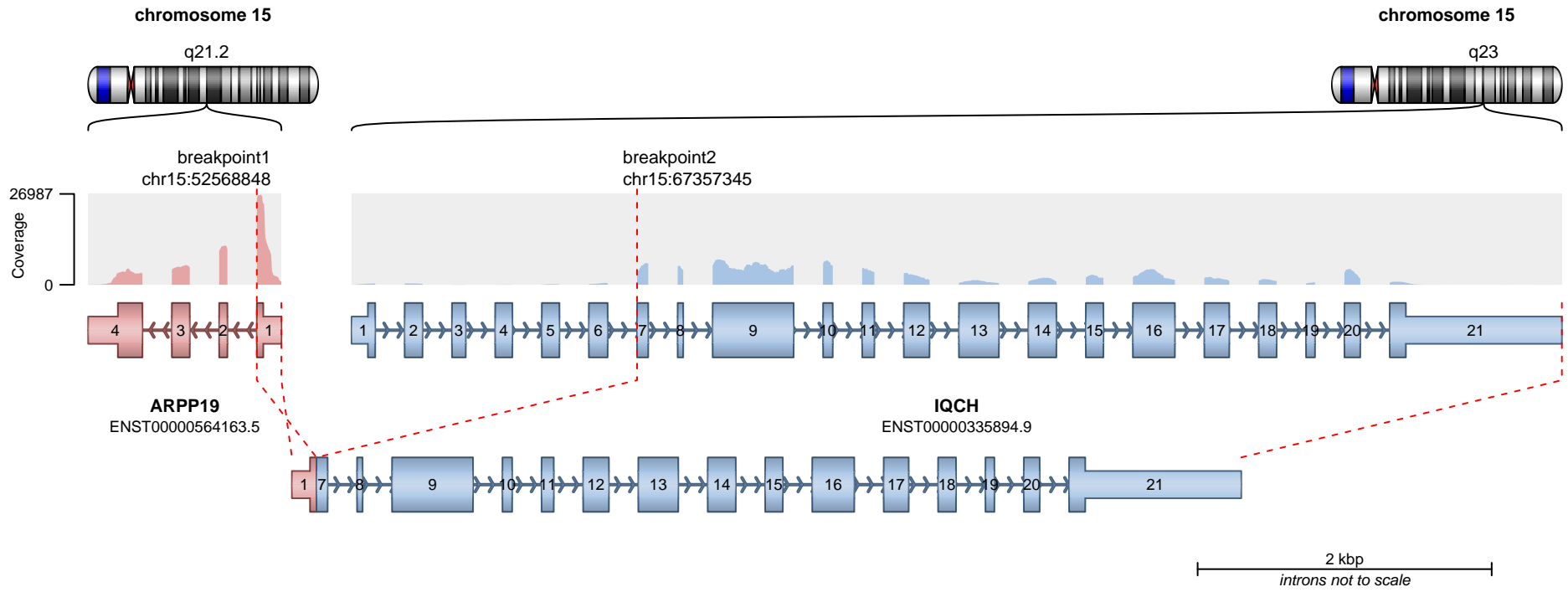

**RETAINED PROTEIN DOMAINS**  
reading frame unclear



**SUPPORTING READ COUNT**

Split reads = 54  
Discordant mates = 0

- translocation
- duplication
- deletion
- inversion

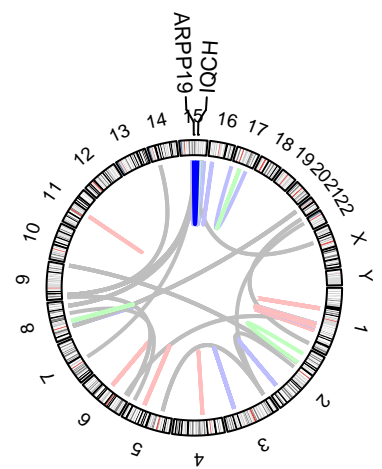
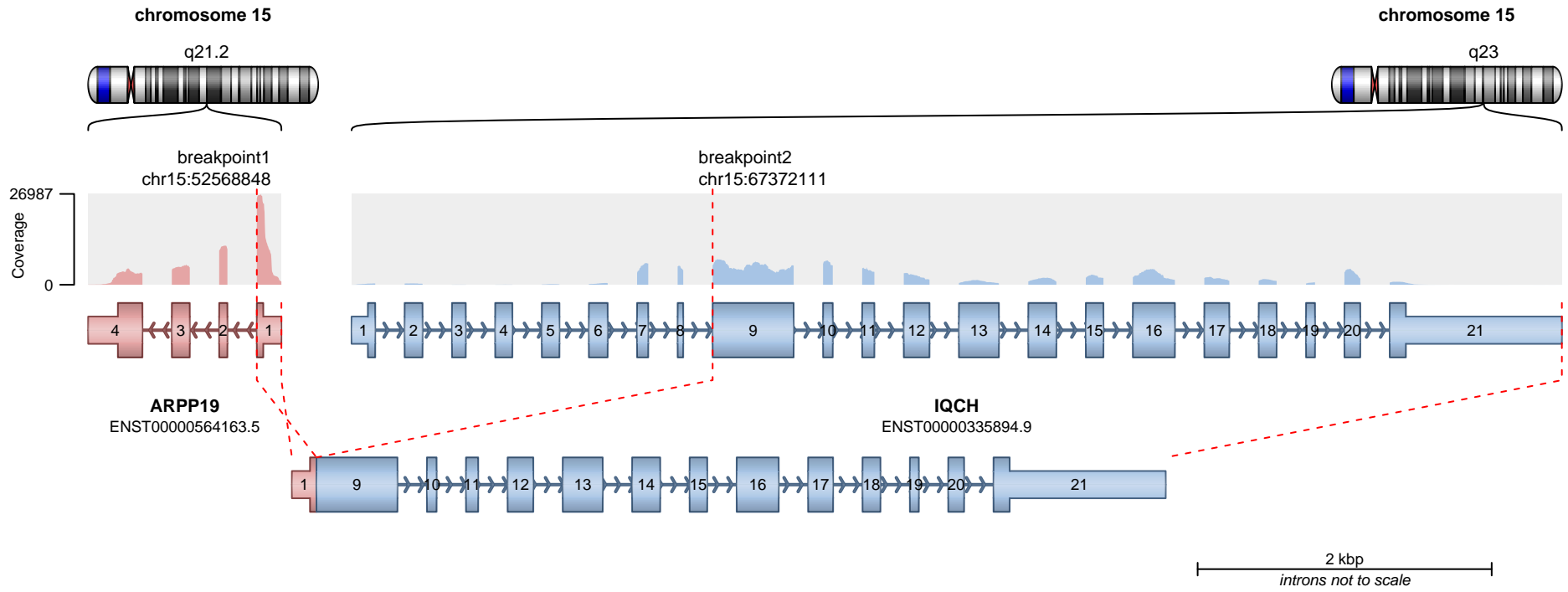

**RETAINED PROTEIN DOMAINS**  
reading frame unclear



**SUPPORTING READ COUNT**

Split reads = 7  
Discordant mates = 0

- translocation
- duplication
- deletion
- inversion

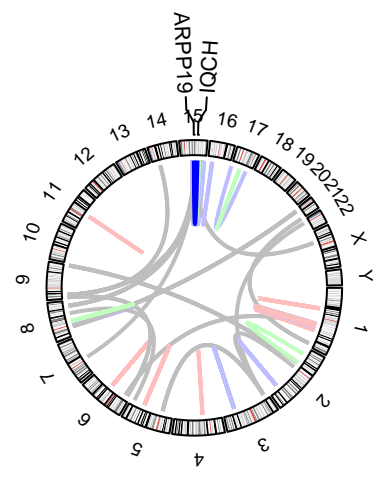
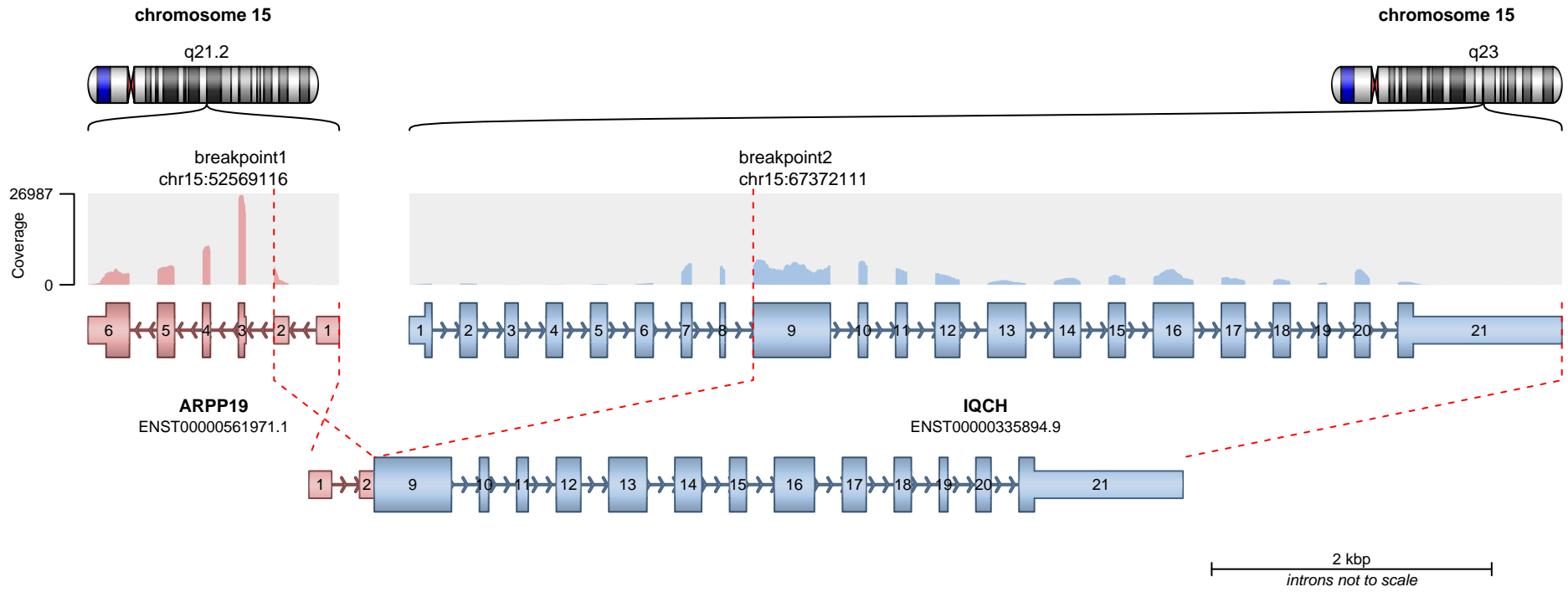

— translocation    — deletion  
— duplication    — inversion

No protein domains retained in fusion.

**SUPPORTING READ COUNT**

Split reads = 1  
Discordant mates = 0

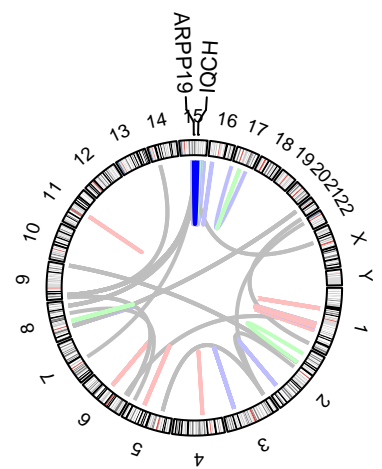
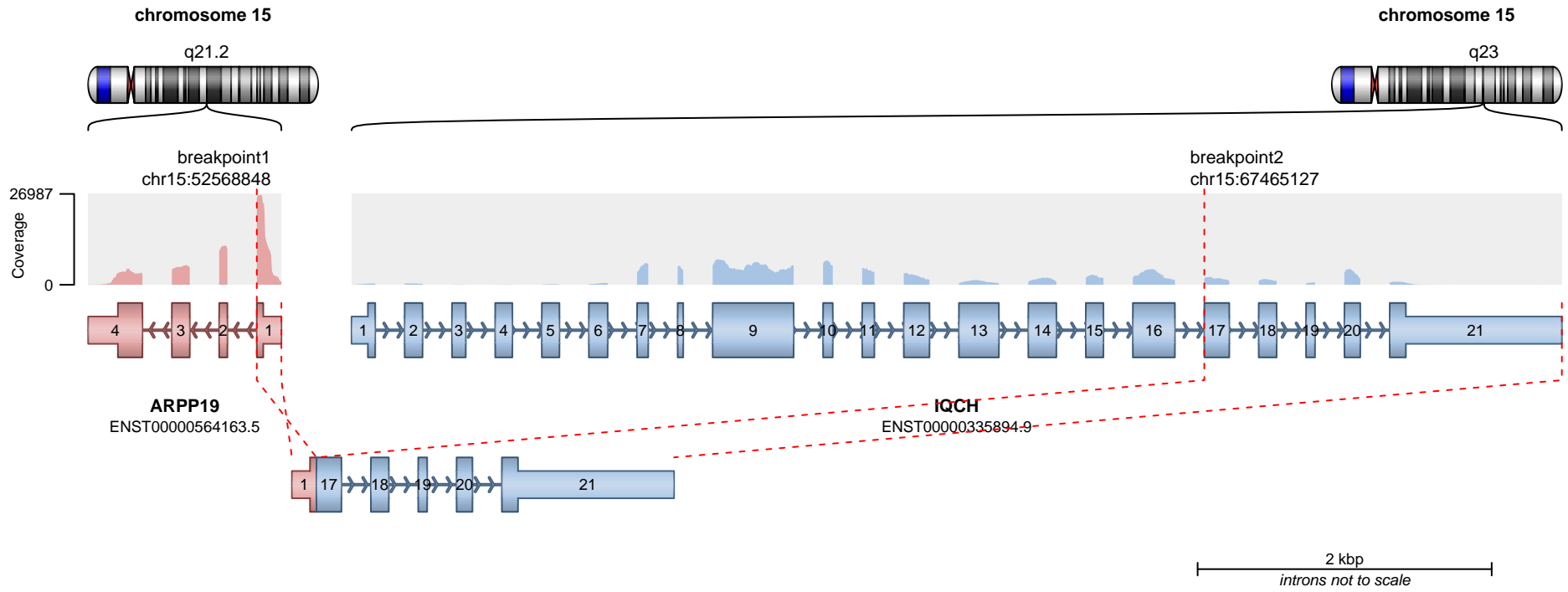

**RETAINED PROTEIN DOMAINS**  
reading frame unclear

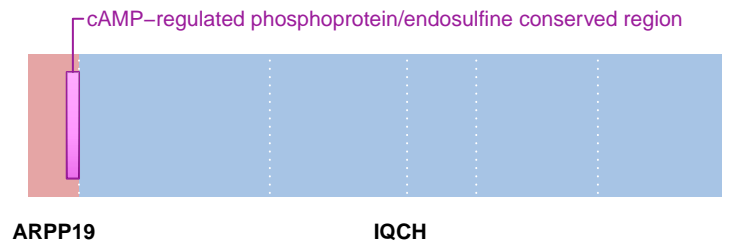

**SUPPORTING READ COUNT**

Split reads = 1  
Discordant mates = 0

- translocation
- duplication
- deletion
- inversion

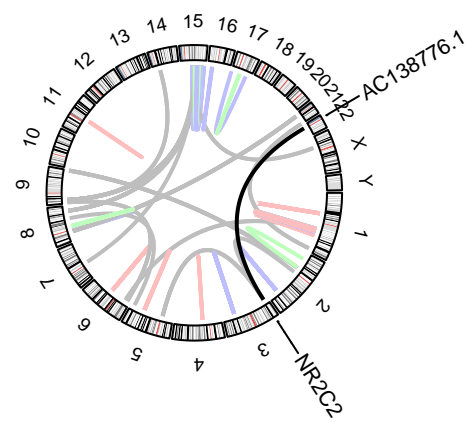
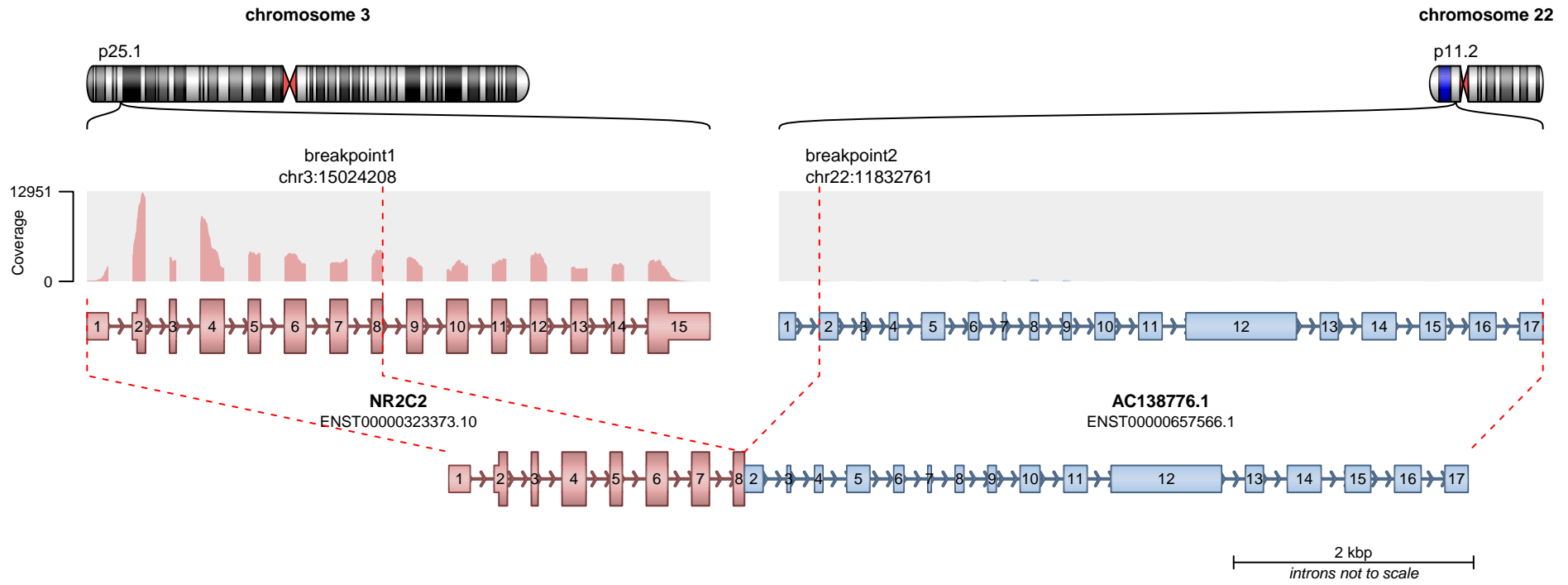

**RETAINED PROTEIN DOMAINS**  
reading frame unclear

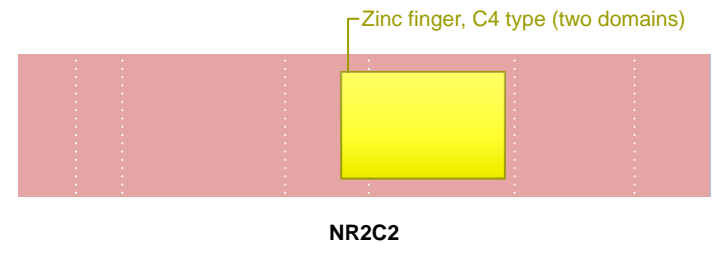

**SUPPORTING READ COUNT**

Split reads = 52  
Discordant mates = 1

- translocation
- duplication
- deletion
- inversion

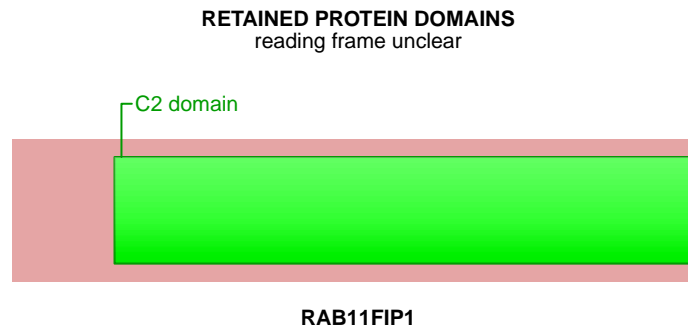
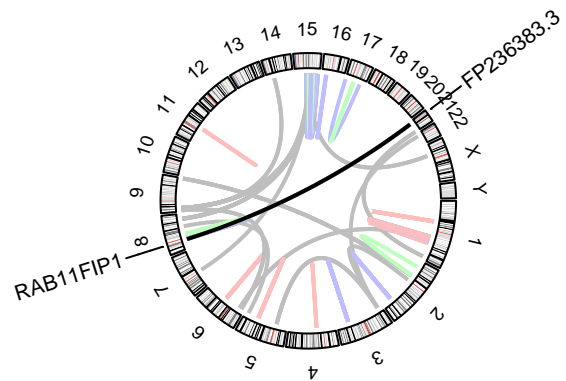
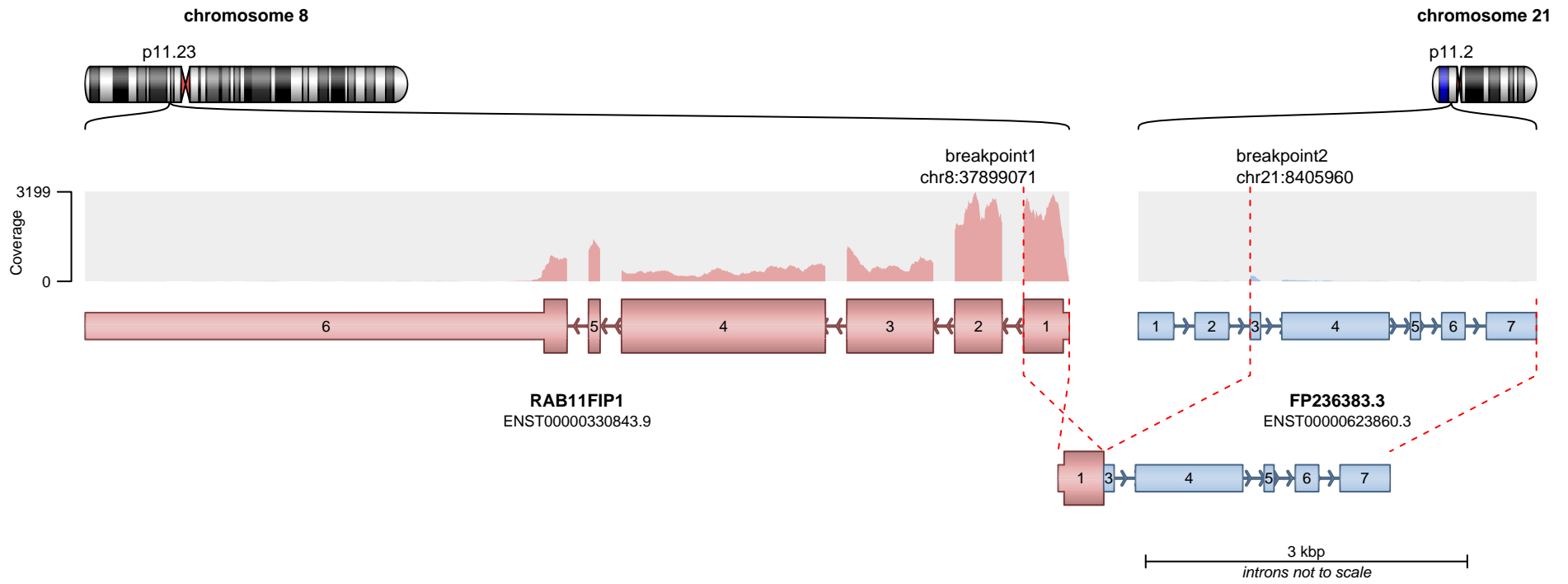

**SUPPORTING READ COUNT**

Split reads = 48  
Discordant mates = 0

- translocation
- duplication
- deletion
- inversion

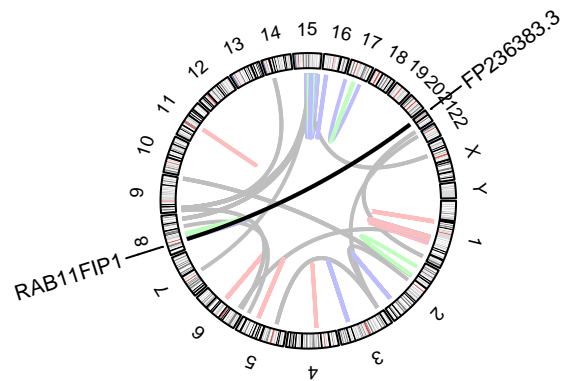
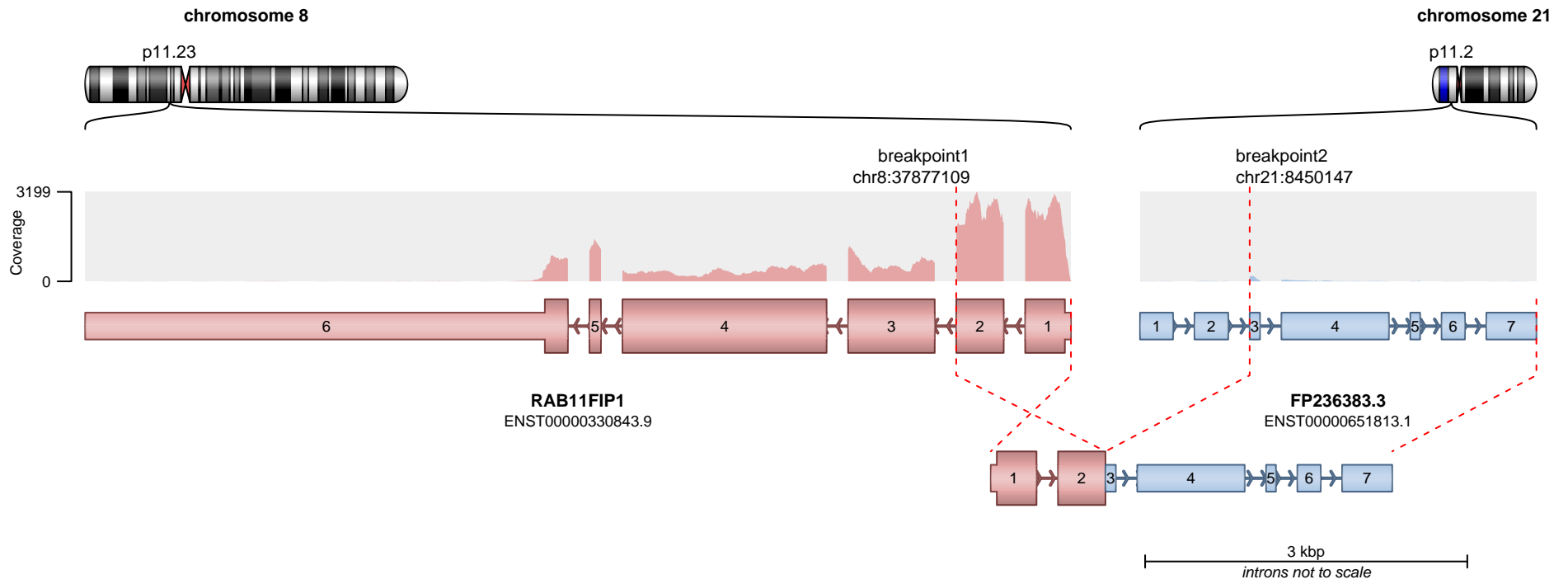

**RETAINED PROTEIN DOMAINS**  
reading frame unclear

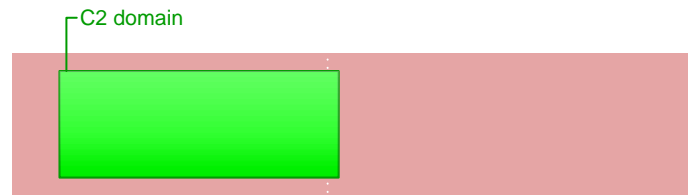

**SUPPORTING READ COUNT**

Split reads = 5  
Discordant mates = 0

- translocation
- duplication
- deletion
- inversion

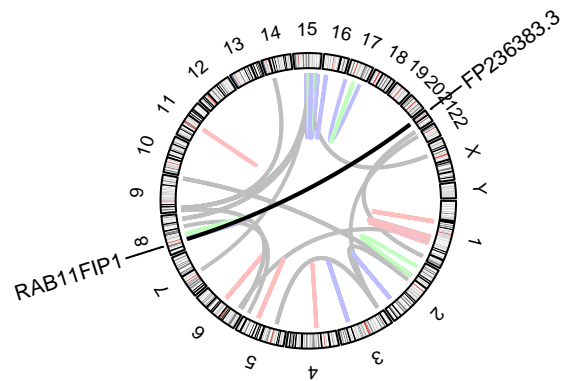
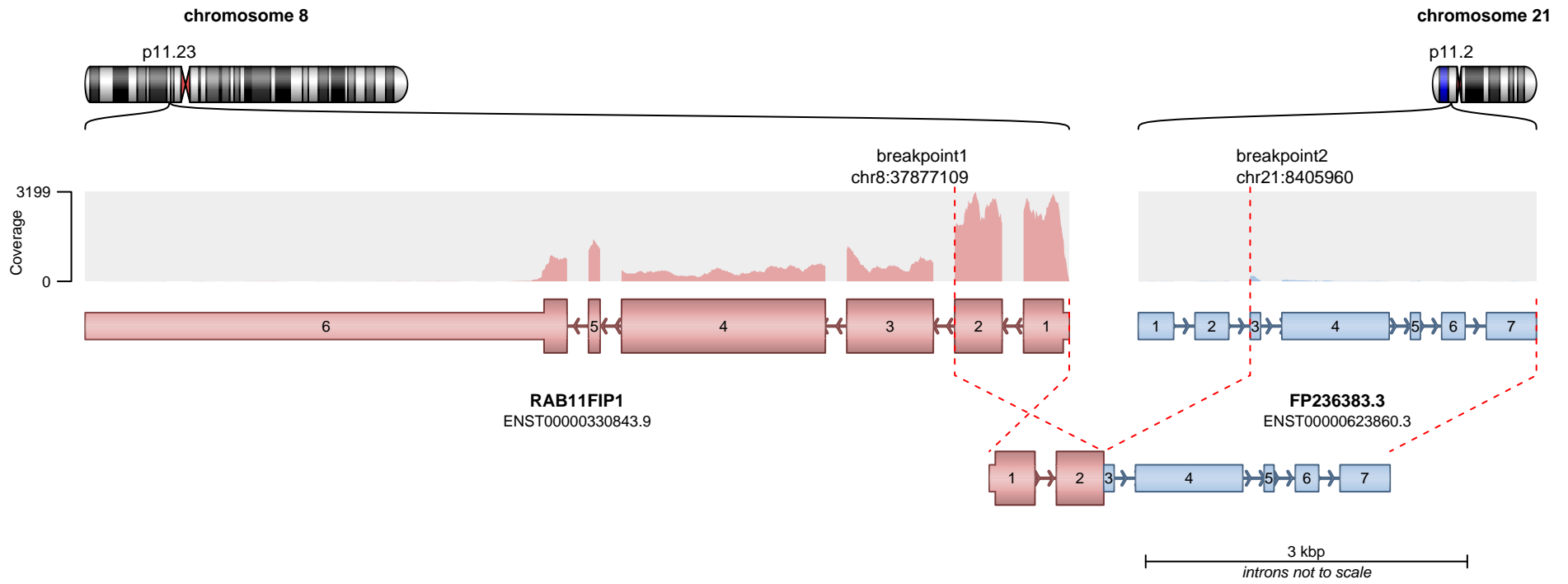

**RETAINED PROTEIN DOMAINS**  
reading frame unclear

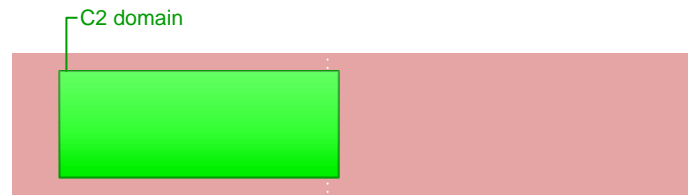

**SUPPORTING READ COUNT**

Split reads = 5  
Discordant mates = 0

- translocation
- duplication
- deletion
- inversion

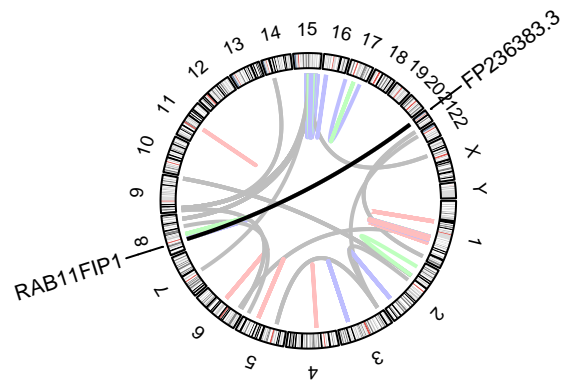
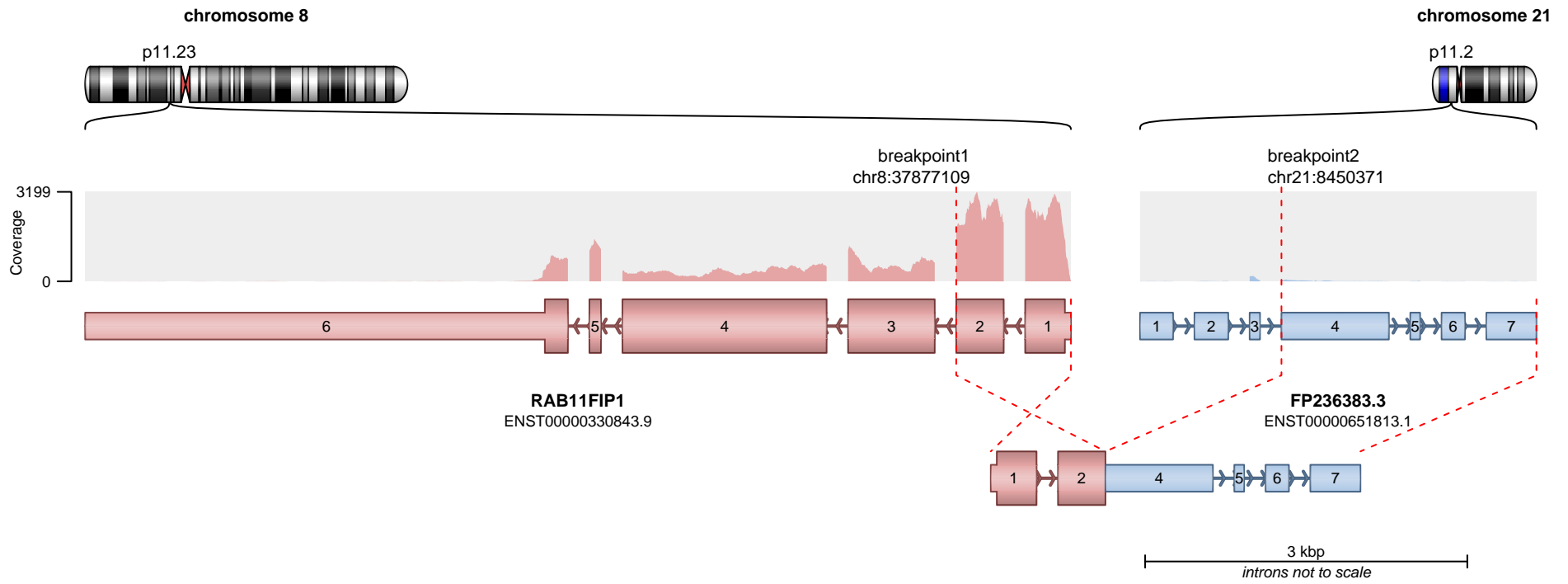

**RETAINED PROTEIN DOMAINS**  
reading frame unclear

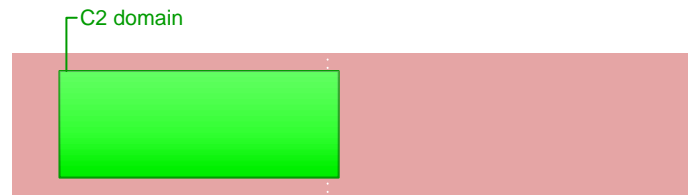

**SUPPORTING READ COUNT**

Split reads = 2  
Discordant mates = 0

- translocation
- deletion
- duplication
- inversion

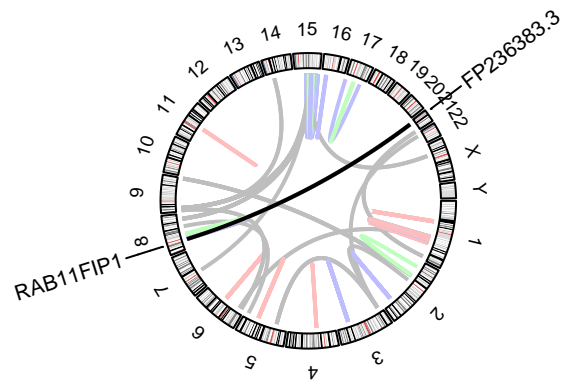
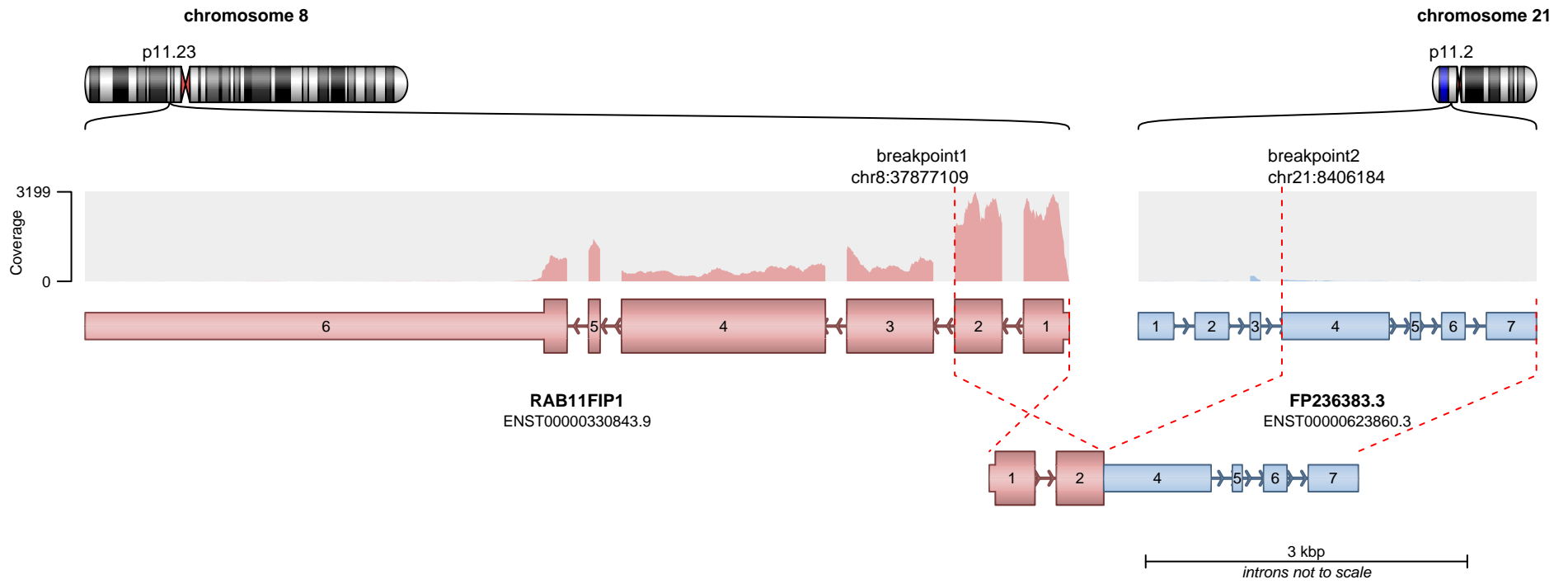

**RETAINED PROTEIN DOMAINS**  
reading frame unclear

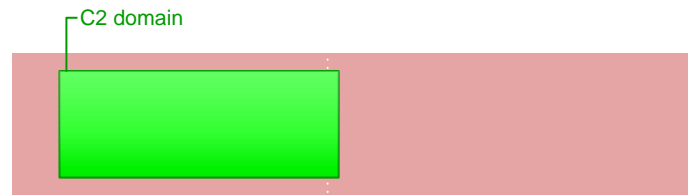

**SUPPORTING READ COUNT**

Split reads = 2  
Discordant mates = 0

- translocation
- duplication
- deletion
- inversion

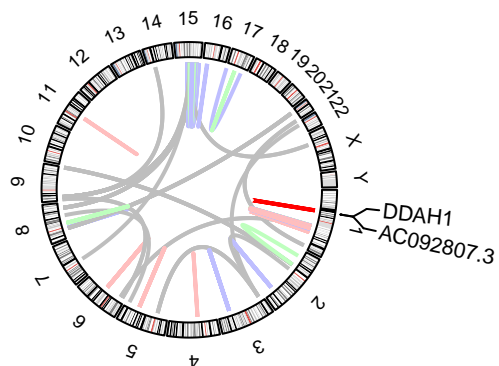
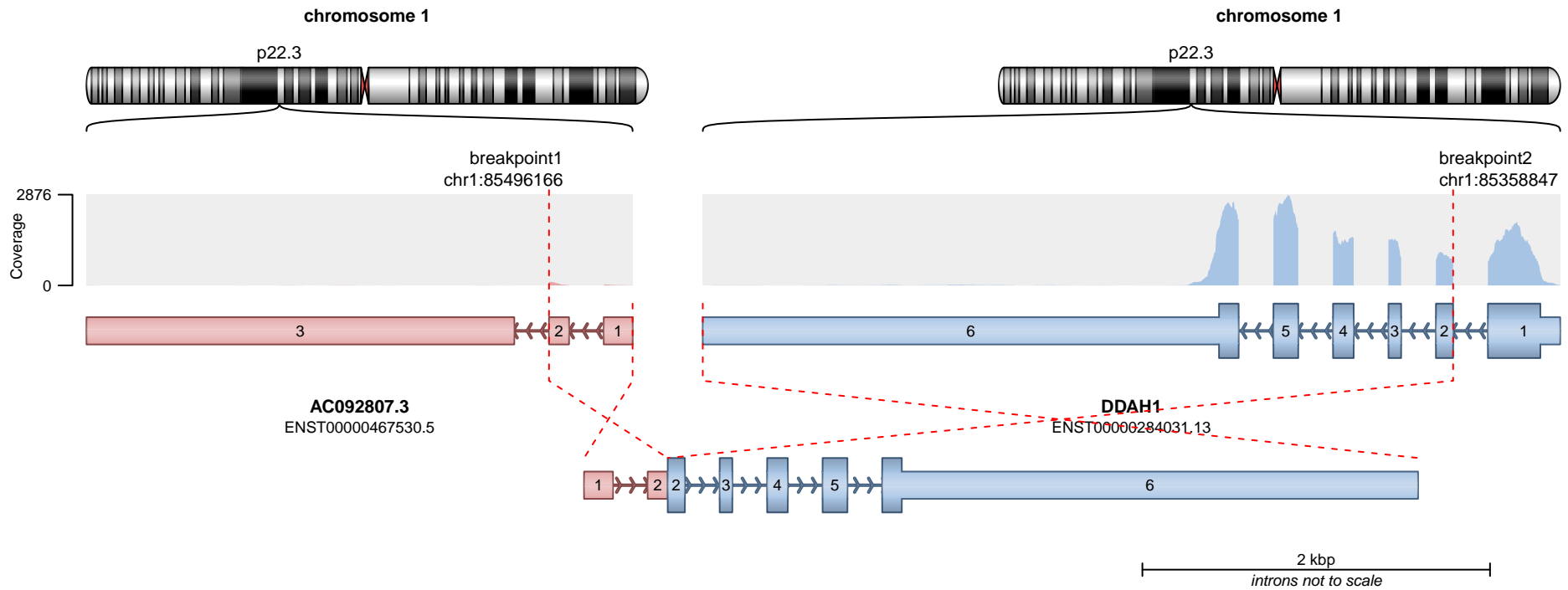

**RETAINED PROTEIN DOMAINS**  
reading frame unclear

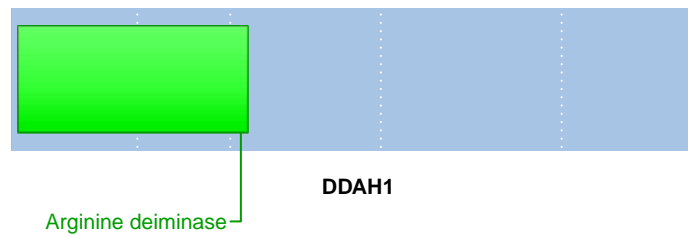

**SUPPORTING READ COUNT**

Split reads = 47  
Discordant mates = 1

- translocation
- duplication
- deletion
- inversion

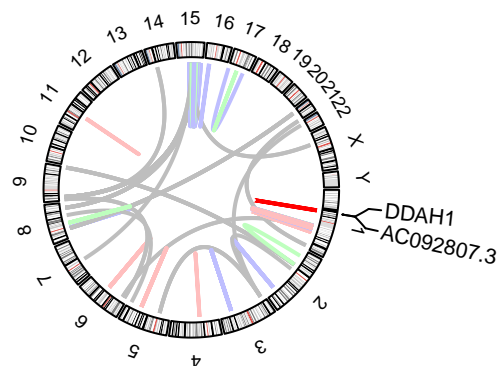
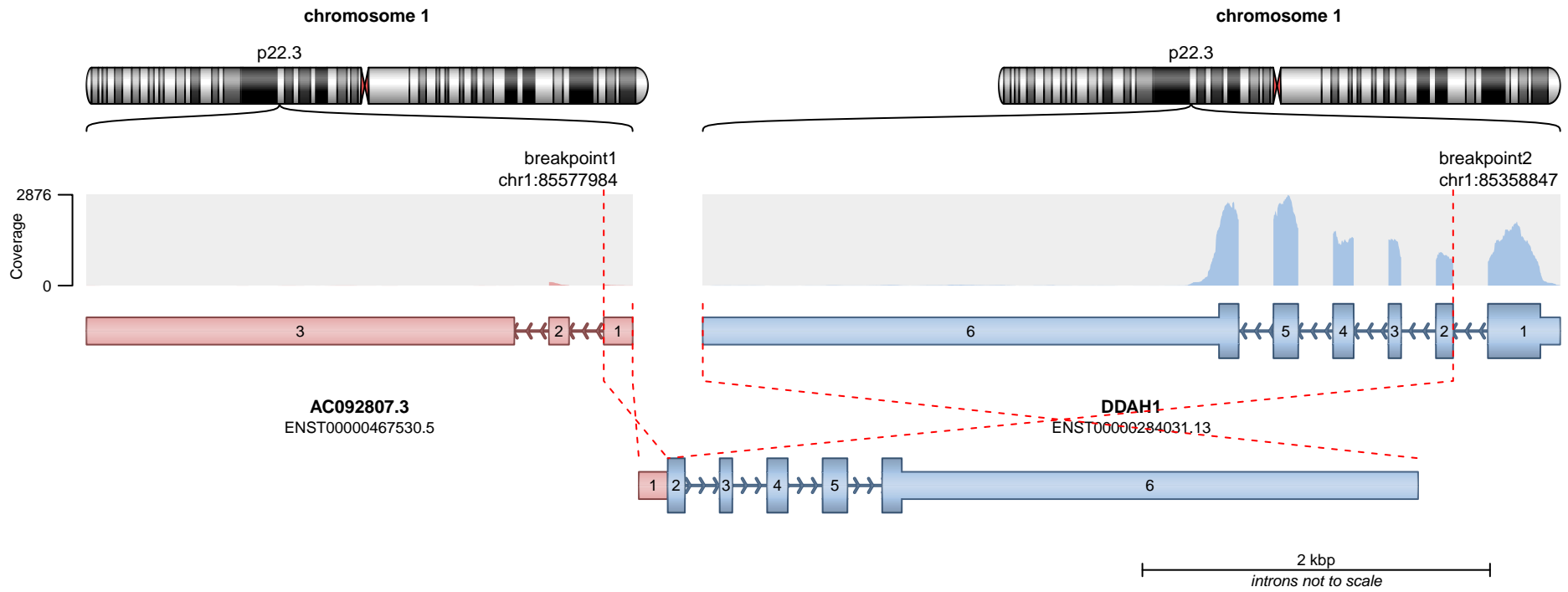

**RETAINED PROTEIN DOMAINS**  
reading frame unclear

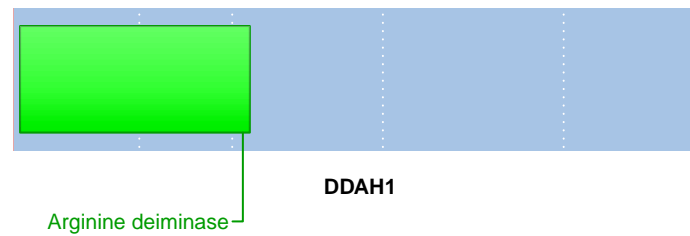

**SUPPORTING READ COUNT**

Split reads = 9  
Discordant mates = 0

- translocation
- duplication
- deletion
- inversion

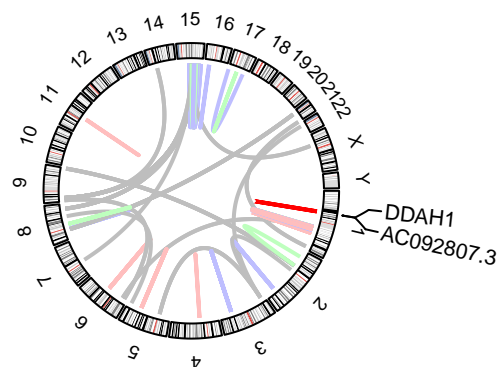
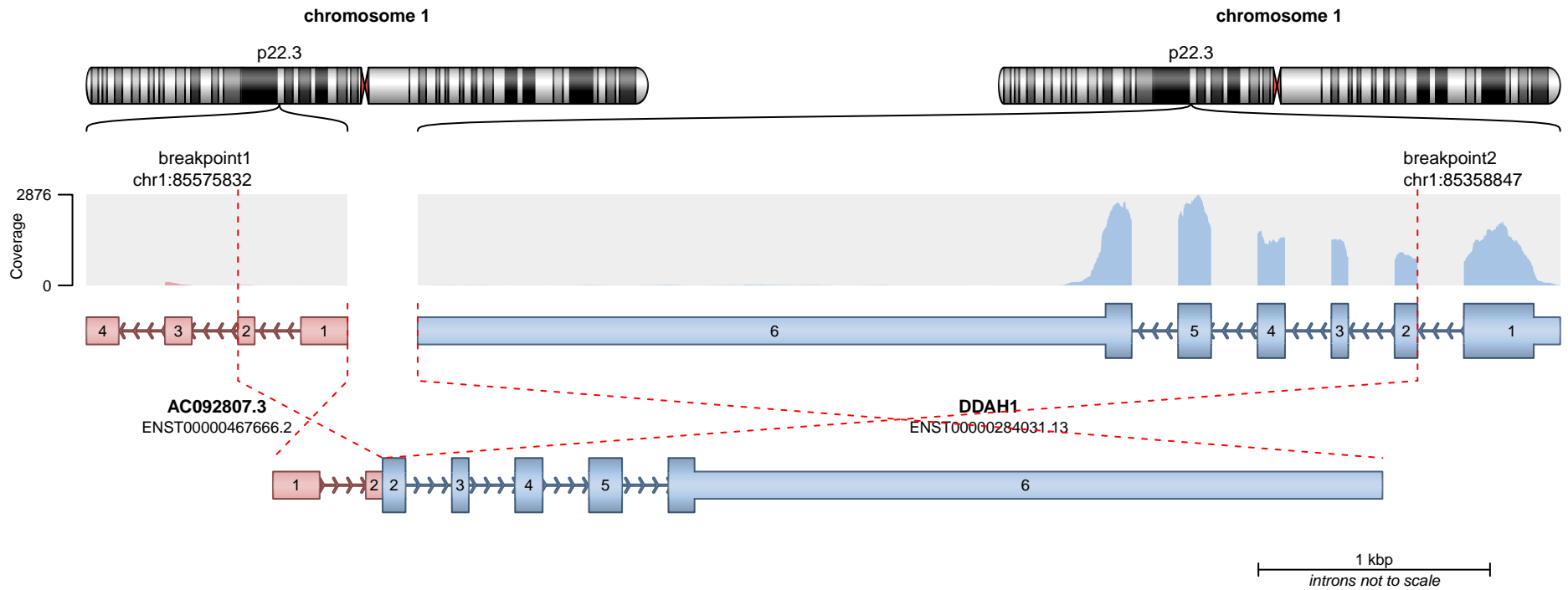

**RETAINED PROTEIN DOMAINS**  
reading frame unclear

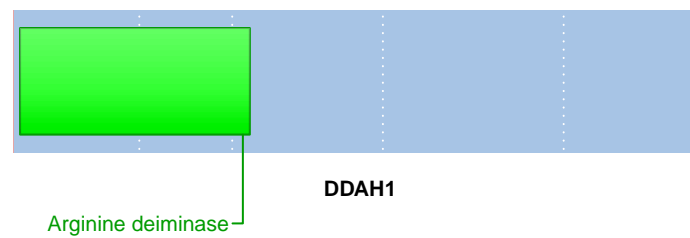

**SUPPORTING READ COUNT**

Split reads = 2  
Discordant mates = 0

- translocation
- duplication
- deletion
- inversion

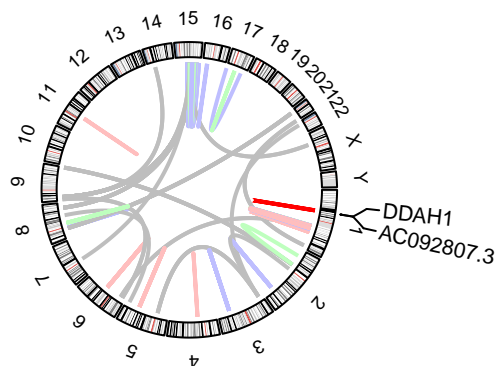
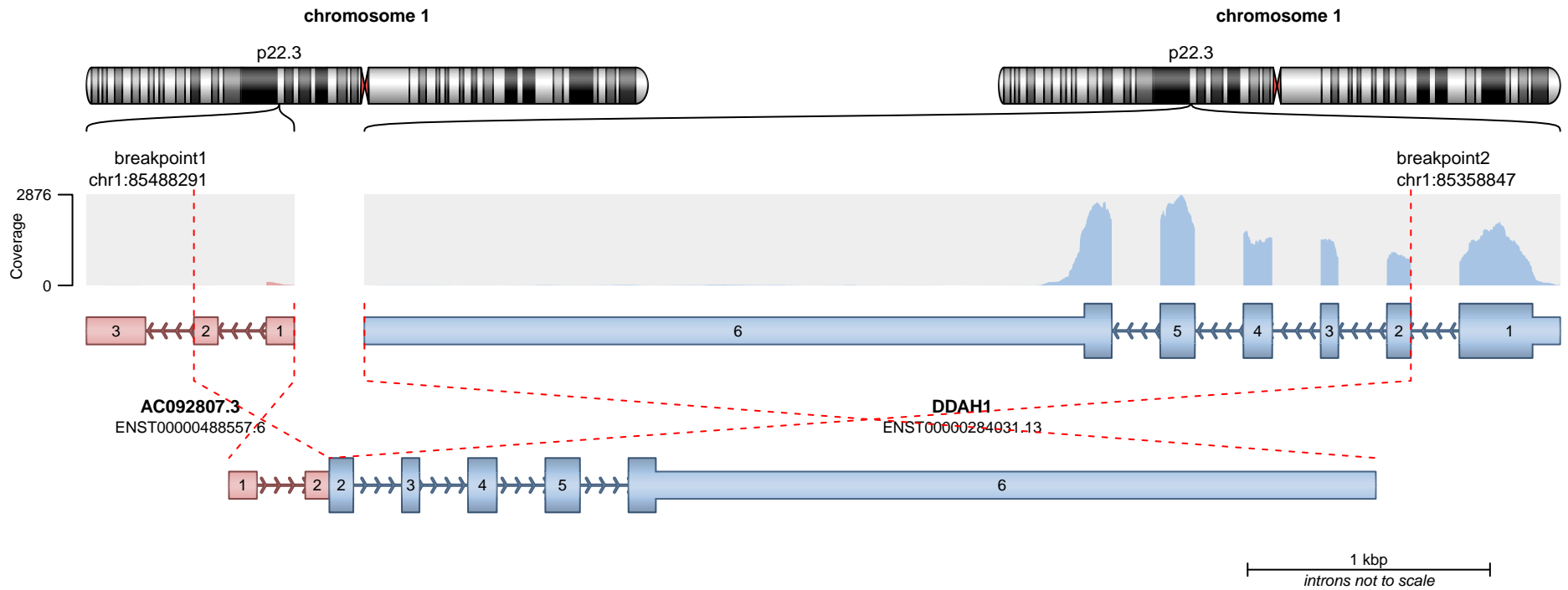

**RETAINED PROTEIN DOMAINS**  
reading frame unclear

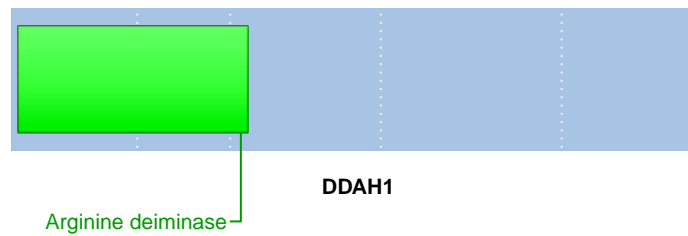

**SUPPORTING READ COUNT**

Split reads = 1  
Discordant mates = 1

- translocation
- duplication
- deletion
- inversion

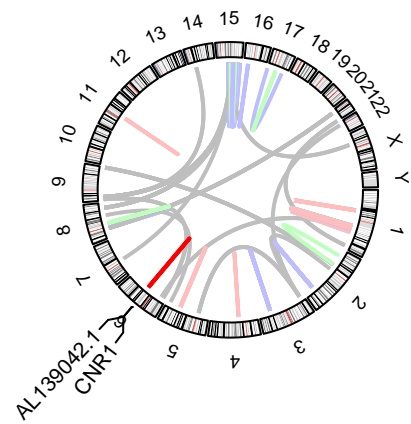
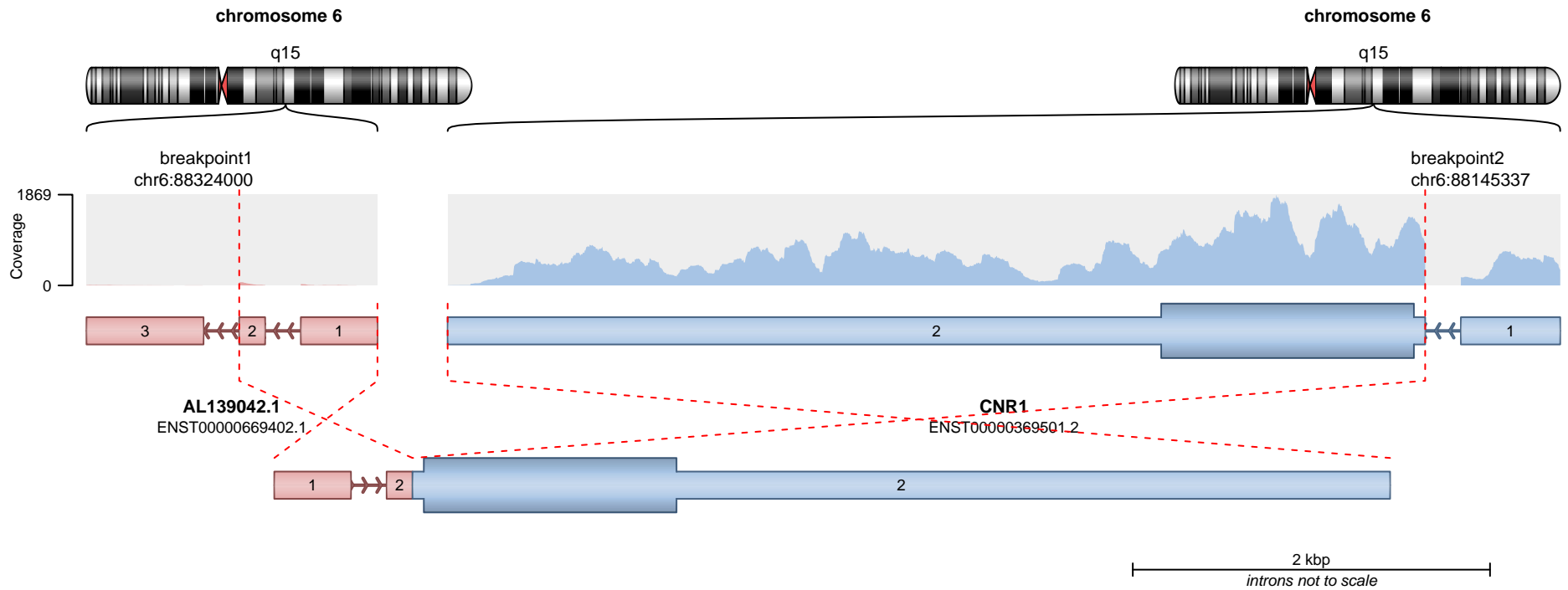

**RETAINED PROTEIN DOMAINS**  
reading frame unclear



**CNR1**  
7 transmembrane receptor (rhodopsin family)

**SUPPORTING READ COUNT**

Split reads = 41  
Discordant mates = 2

— translocation    — deletion  
— duplication    — inversion

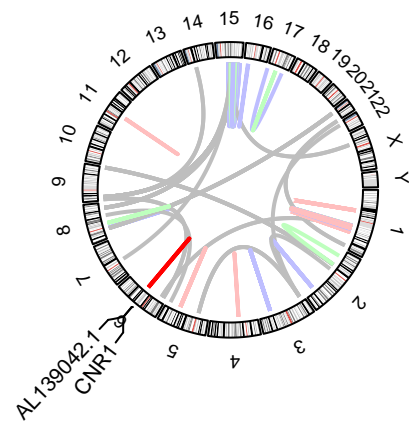
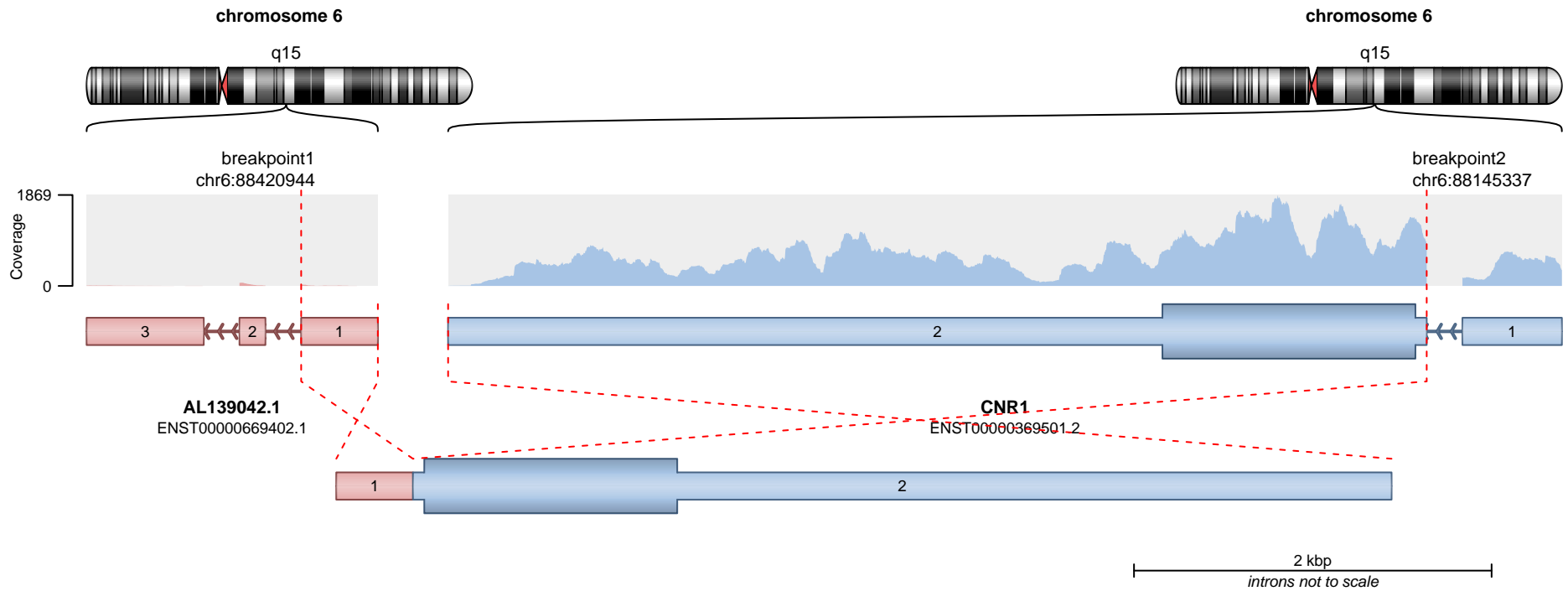

**RETAINED PROTEIN DOMAINS**  
reading frame unclear



**CNR1**  
7 transmembrane receptor (rhodopsin family)

**SUPPORTING READ COUNT**

Split reads = 11  
Discordant mates = 1

— translocation    — deletion  
— duplication    — inversion

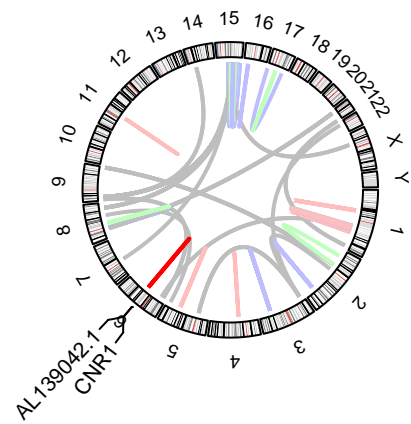
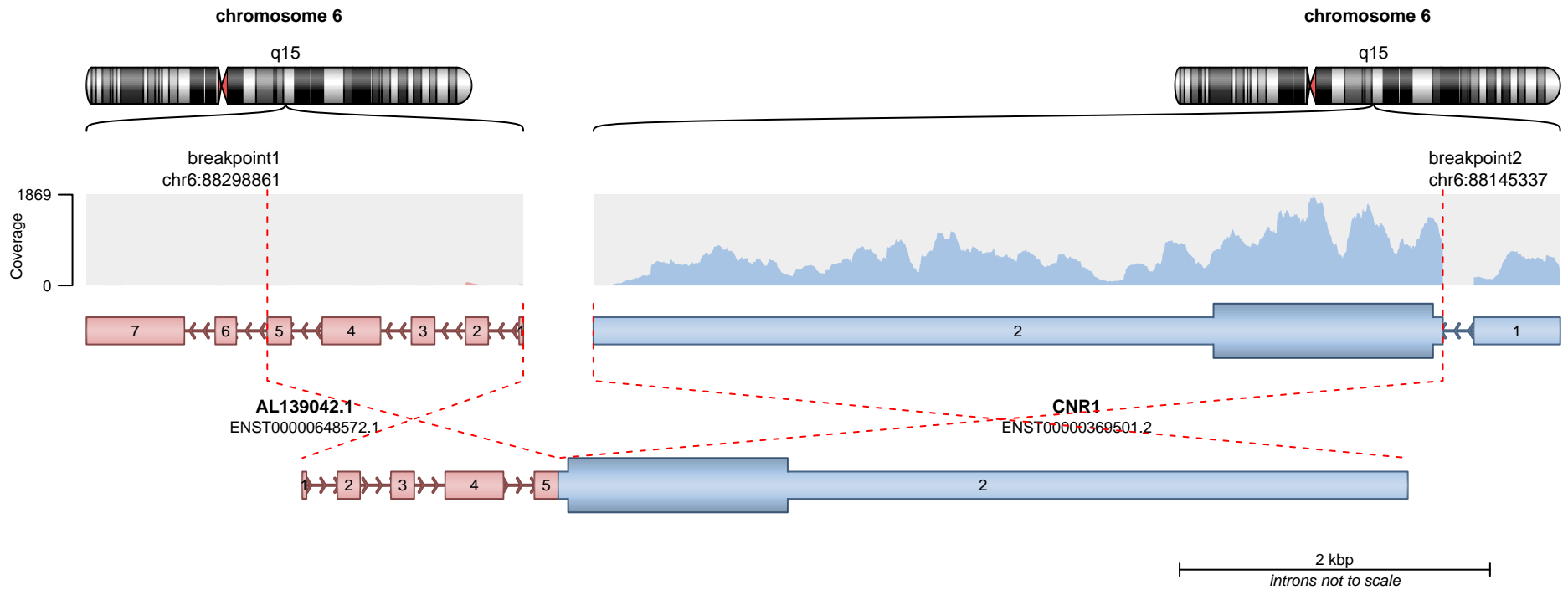

**RETAINED PROTEIN DOMAINS**  
reading frame unclear



**CNR1**  
7 transmembrane receptor (rhodopsin family)

**SUPPORTING READ COUNT**

Split reads = 10  
Discordant mates = 2

— translocation    — deletion  
— duplication    — inversion

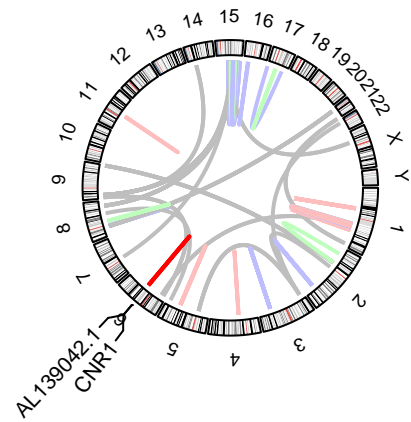
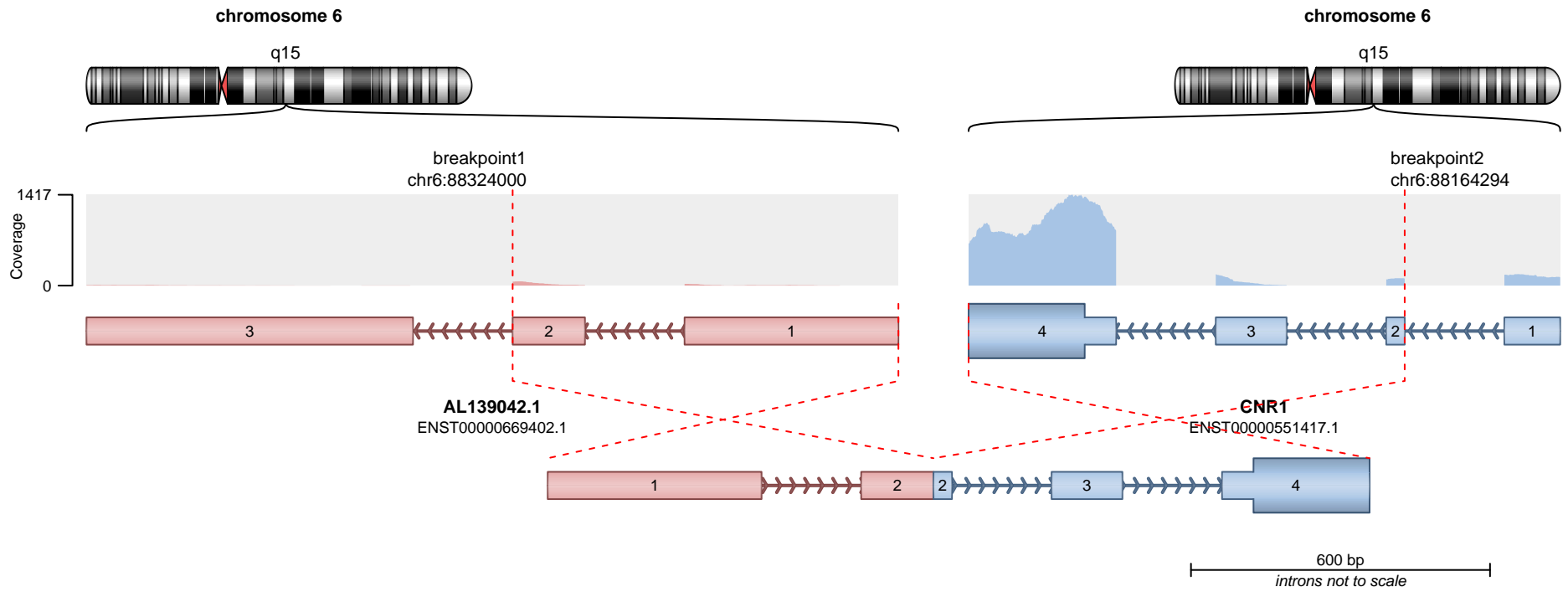

— translocation    — deletion  
— duplication    — inversion

No protein domains retained in fusion.

**SUPPORTING READ COUNT**

Split reads = 1  
Discordant mates = 2

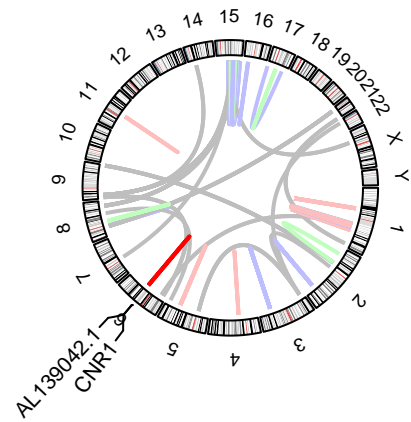
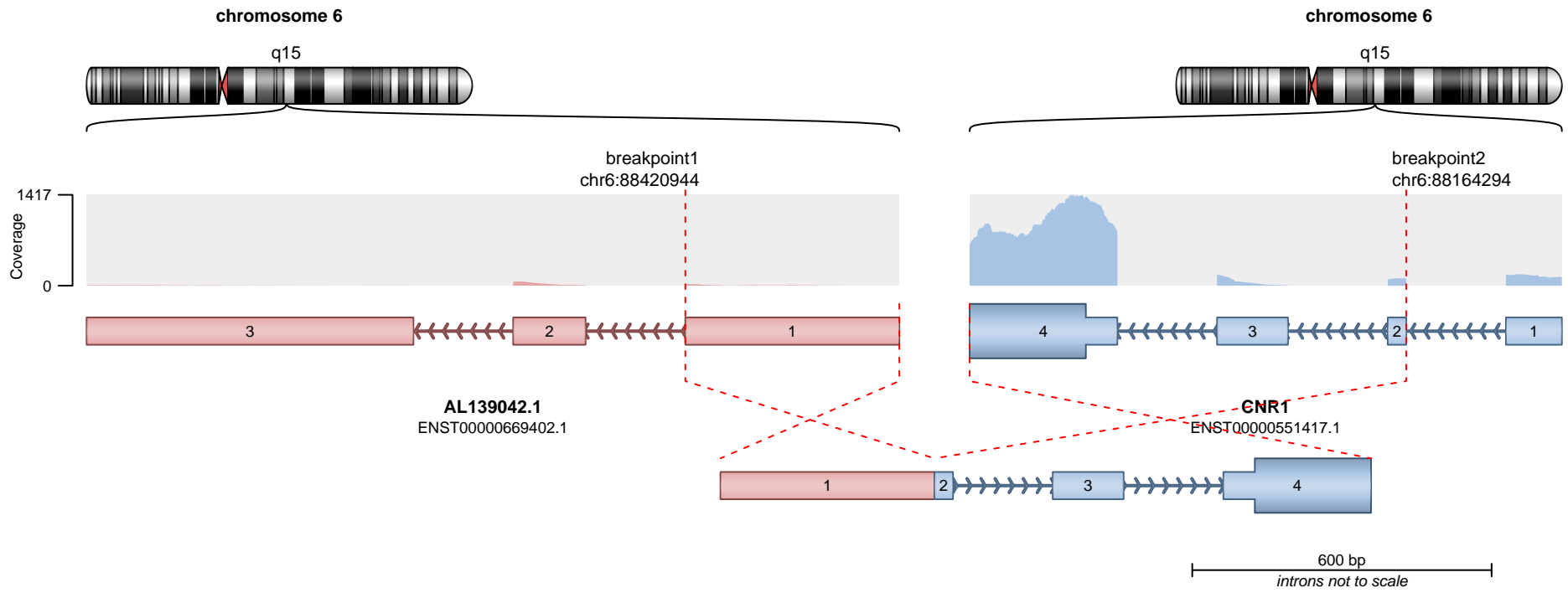

— translocation    — deletion  
— duplication    — inversion

No protein domains retained in fusion.

**SUPPORTING READ COUNT**

Split reads = 1  
Discordant mates = 1

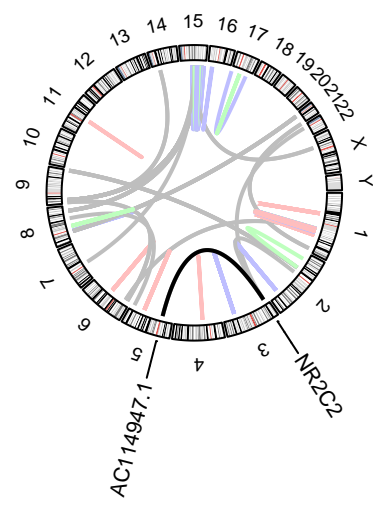
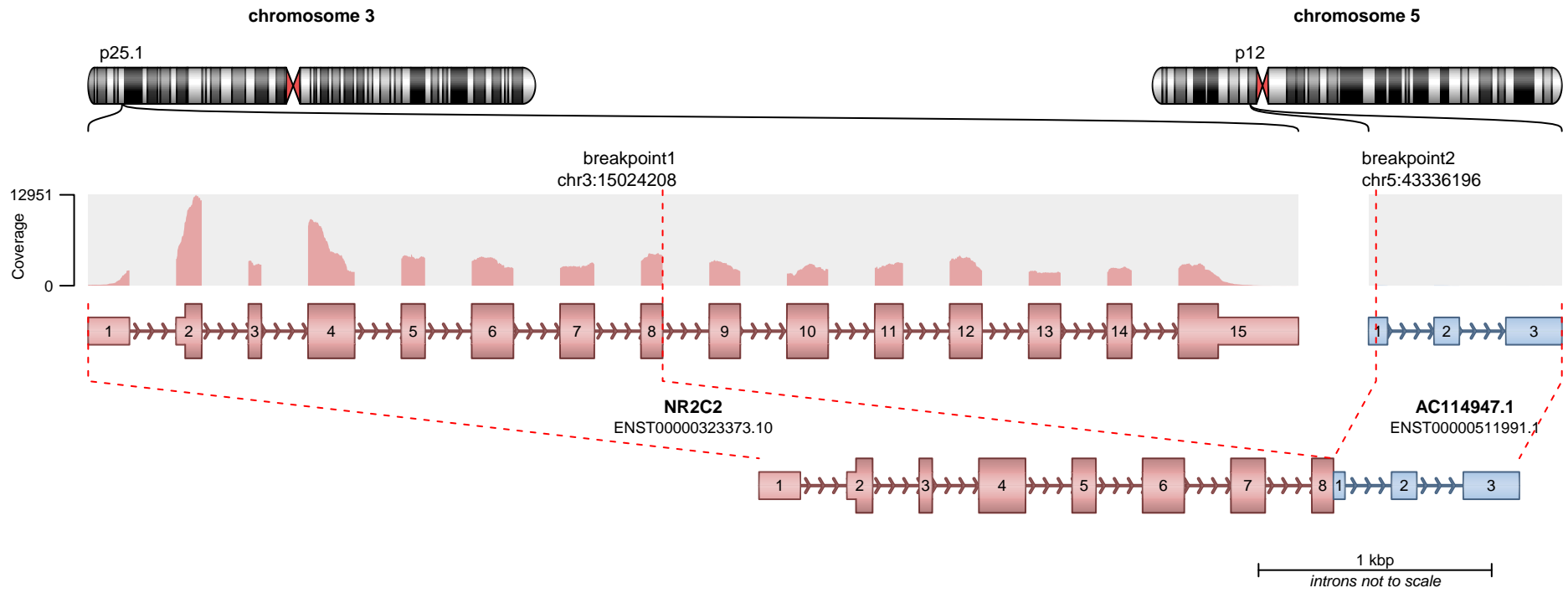

— translocation — deletion  
— duplication — inversion

**RETAINED PROTEIN DOMAINS**  
reading frame unclear

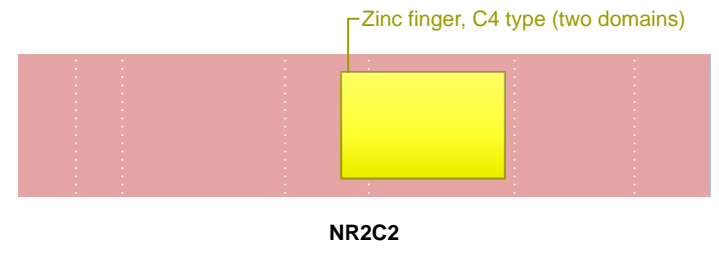

**SUPPORTING READ COUNT**

Split reads = 39  
Discordant mates = 3

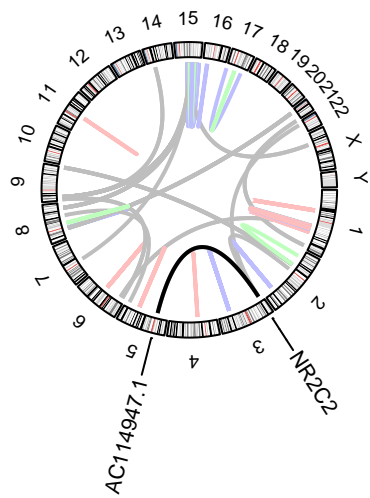
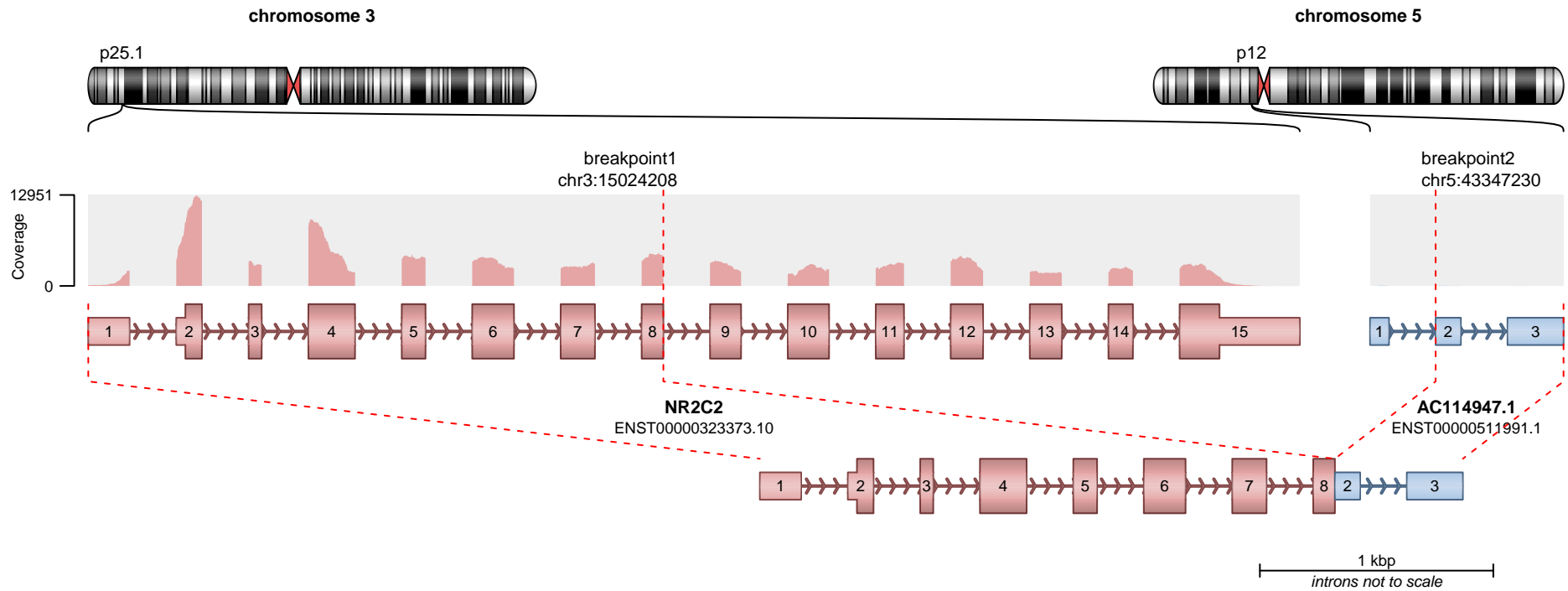

— translocation — deletion  
— duplication — inversion

**RETAINED PROTEIN DOMAINS**  
reading frame unclear

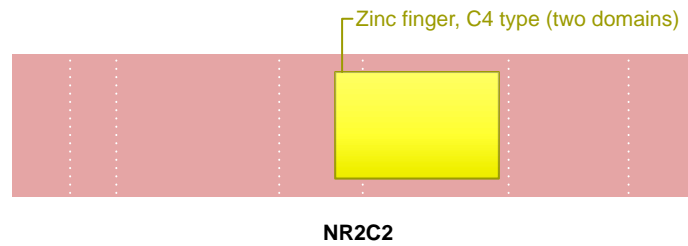

**SUPPORTING READ COUNT**

Split reads = 16  
Discordant mates = 2

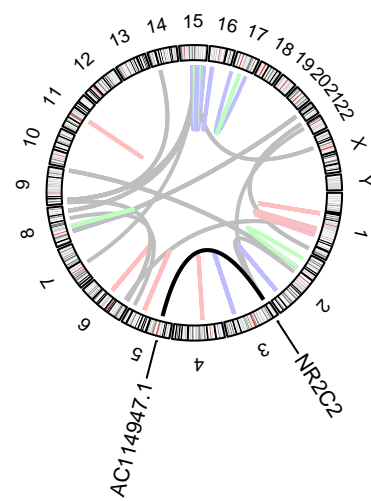
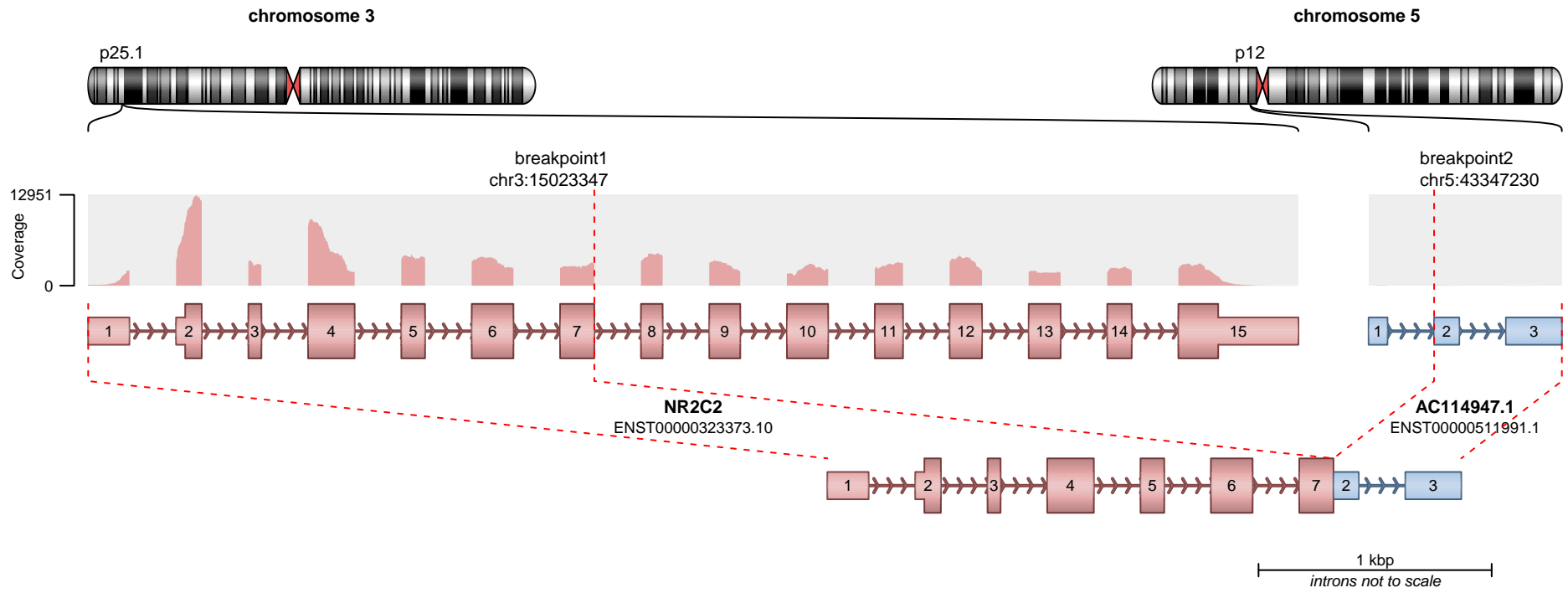

— translocation — deletion  
— duplication — inversion

**RETAINED PROTEIN DOMAINS**  
reading frame unclear

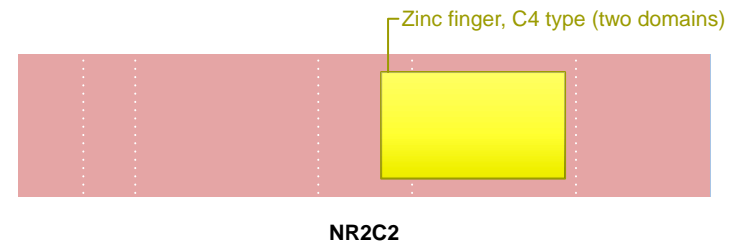

**SUPPORTING READ COUNT**

Split reads = 1  
Discordant mates = 2

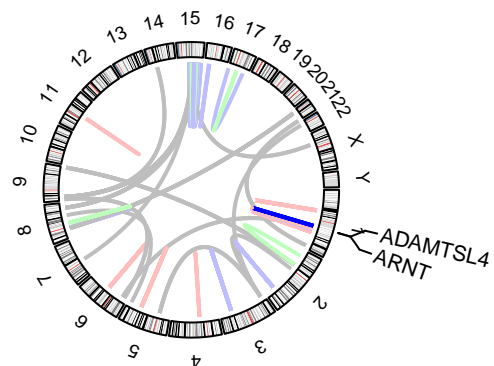
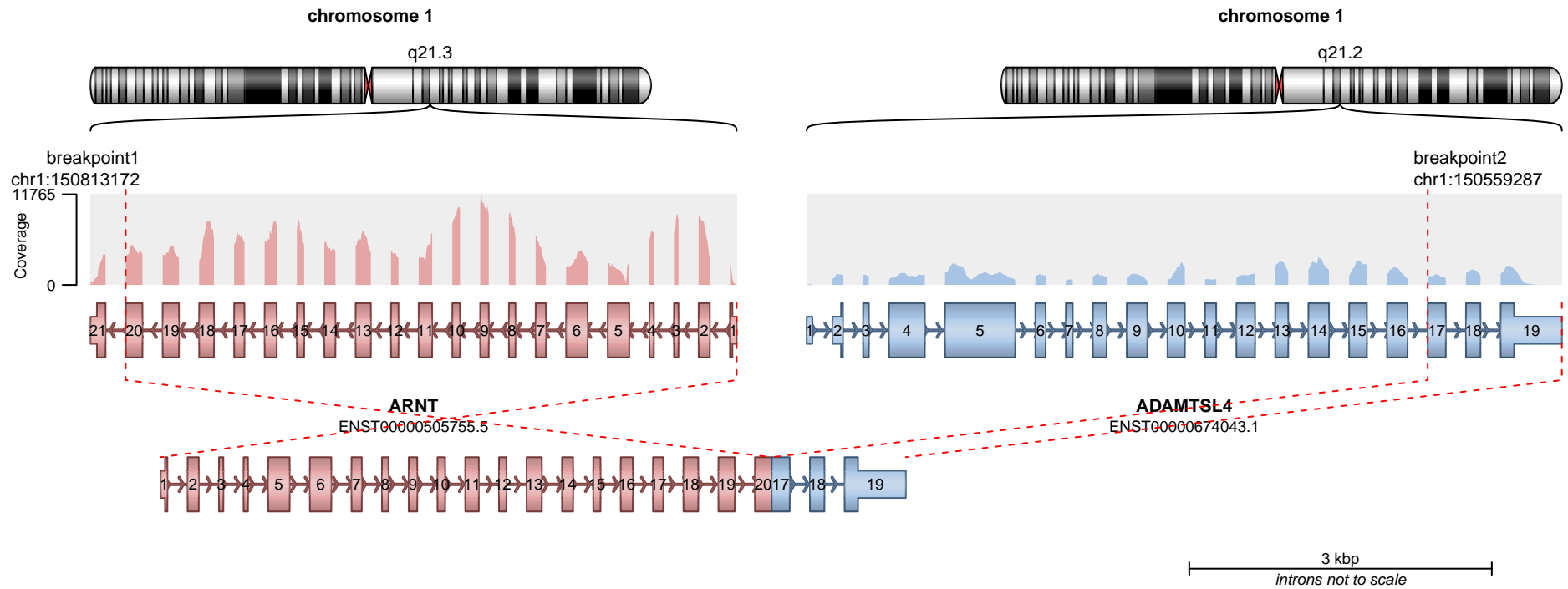

**RETAINED PROTEIN DOMAINS**  
reading frame unclear

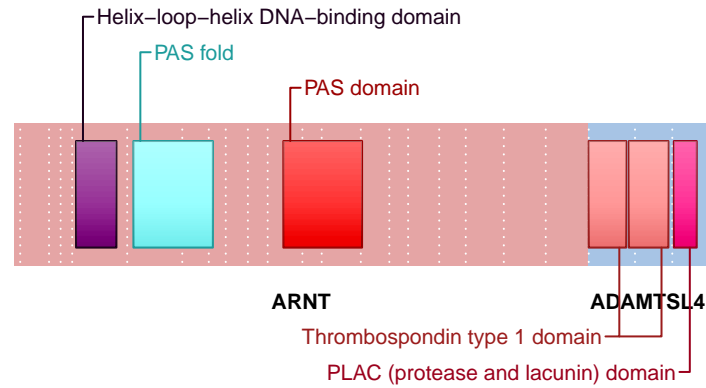

**SUPPORTING READ COUNT**

Split reads = 34  
Discordant mates = 0

— translocation — deletion  
— duplication — inversion

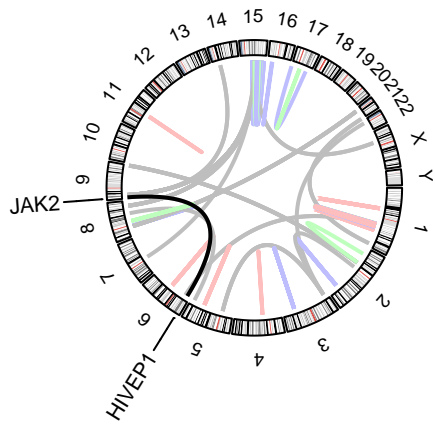
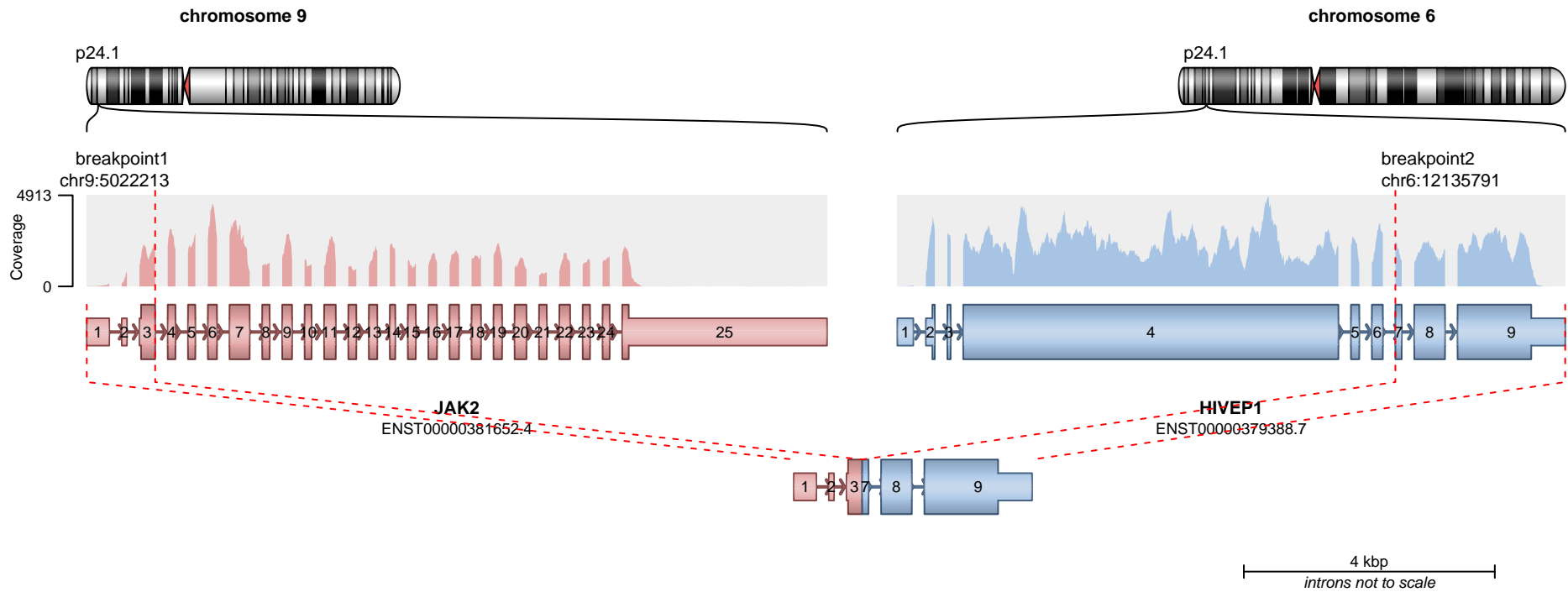

**RETAINED PROTEIN DOMAINS**  
reading frame unclear

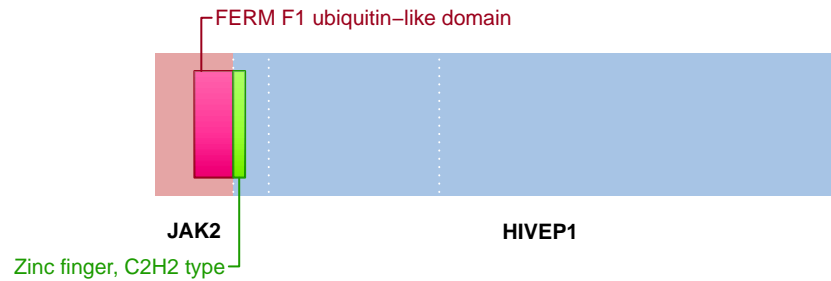

**SUPPORTING READ COUNT**

Split reads = 32  
Discordant mates = 0

- translocation
- duplication
- deletion
- inversion

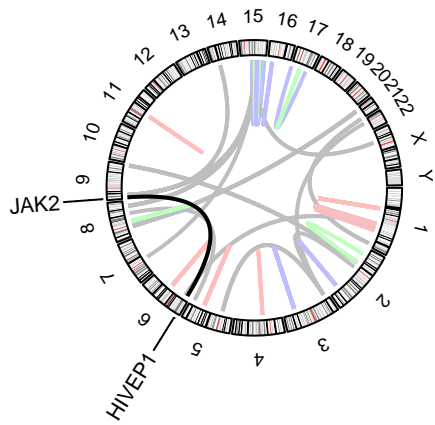
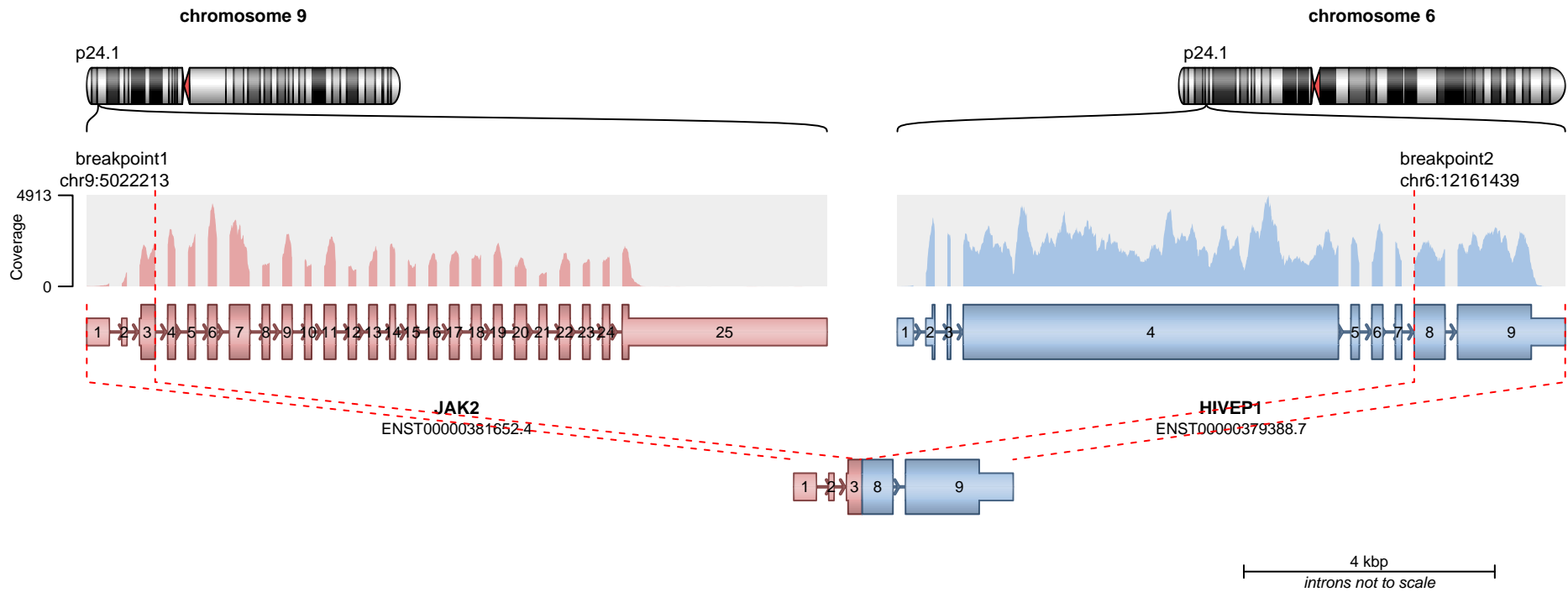

**RETAINED PROTEIN DOMAINS**  
reading frame unclear

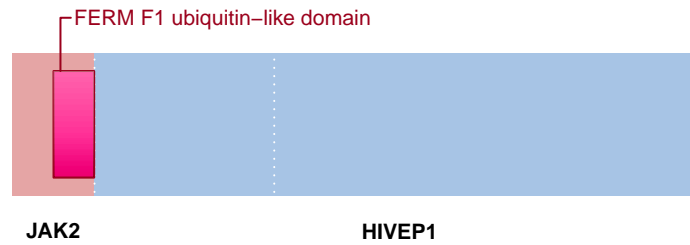

**SUPPORTING READ COUNT**

Split reads = 14  
Discordant mates = 0

- translocation
- duplication
- deletion
- inversion

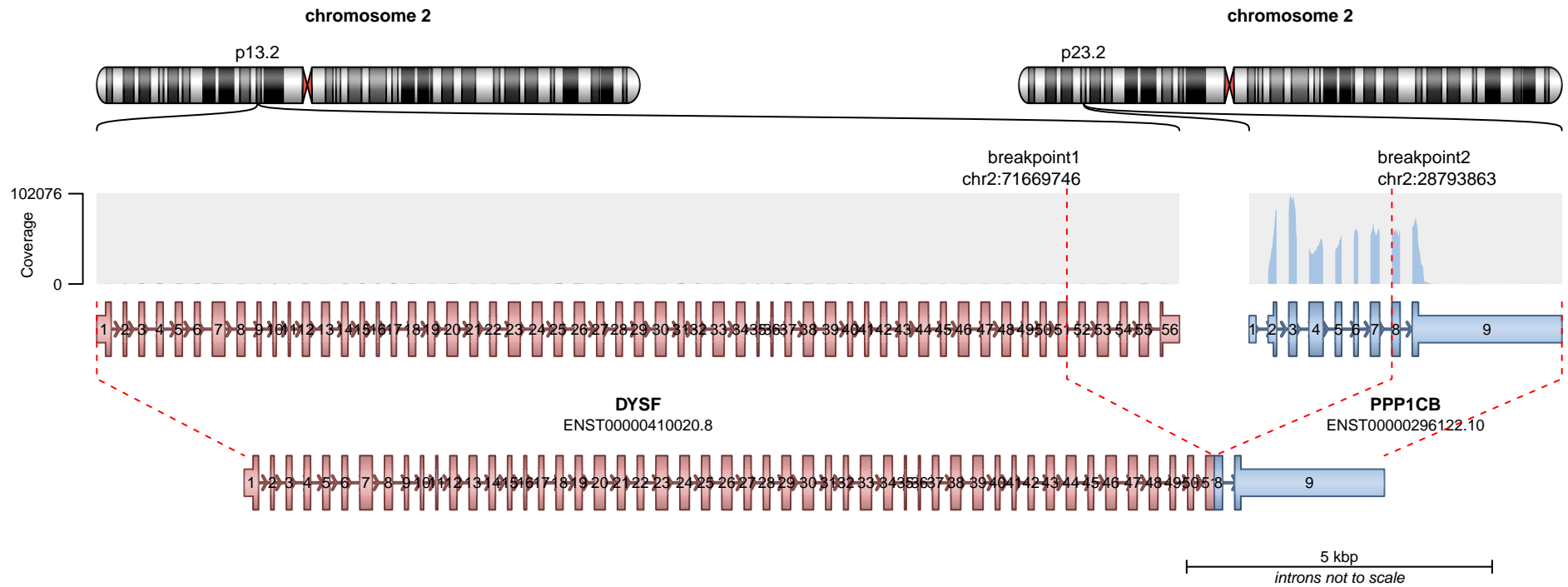

**RETAINED PROTEIN DOMAINS**  
reading frame unclear

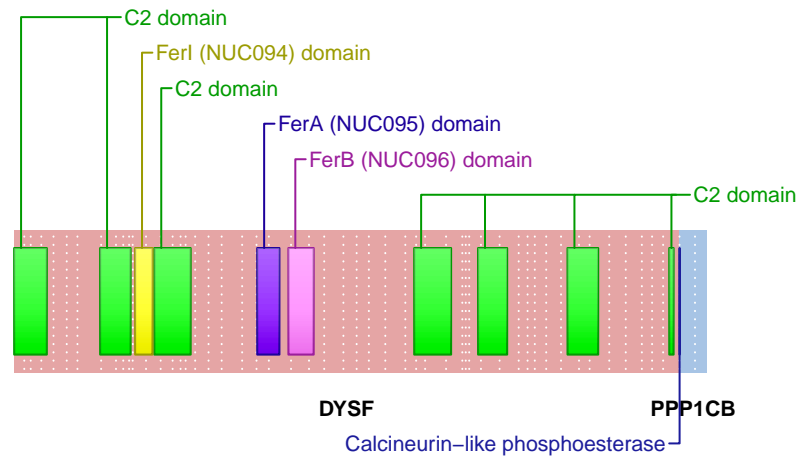
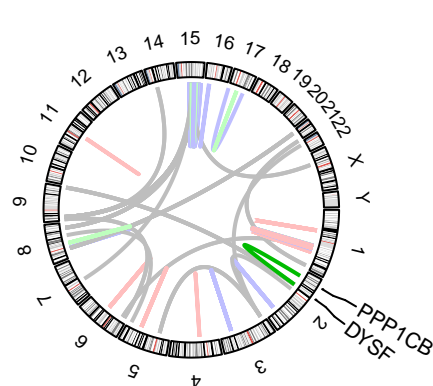

**SUPPORTING READ COUNT**

Split reads = 23  
Discordant mates = 0

- translocation
- duplication
- deletion
- inversion

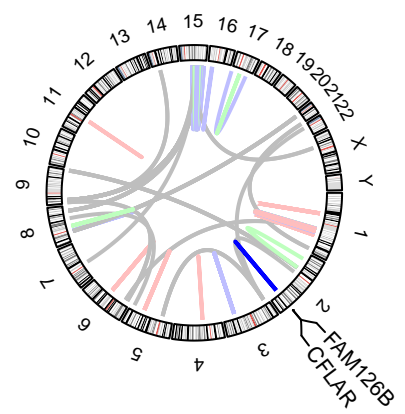
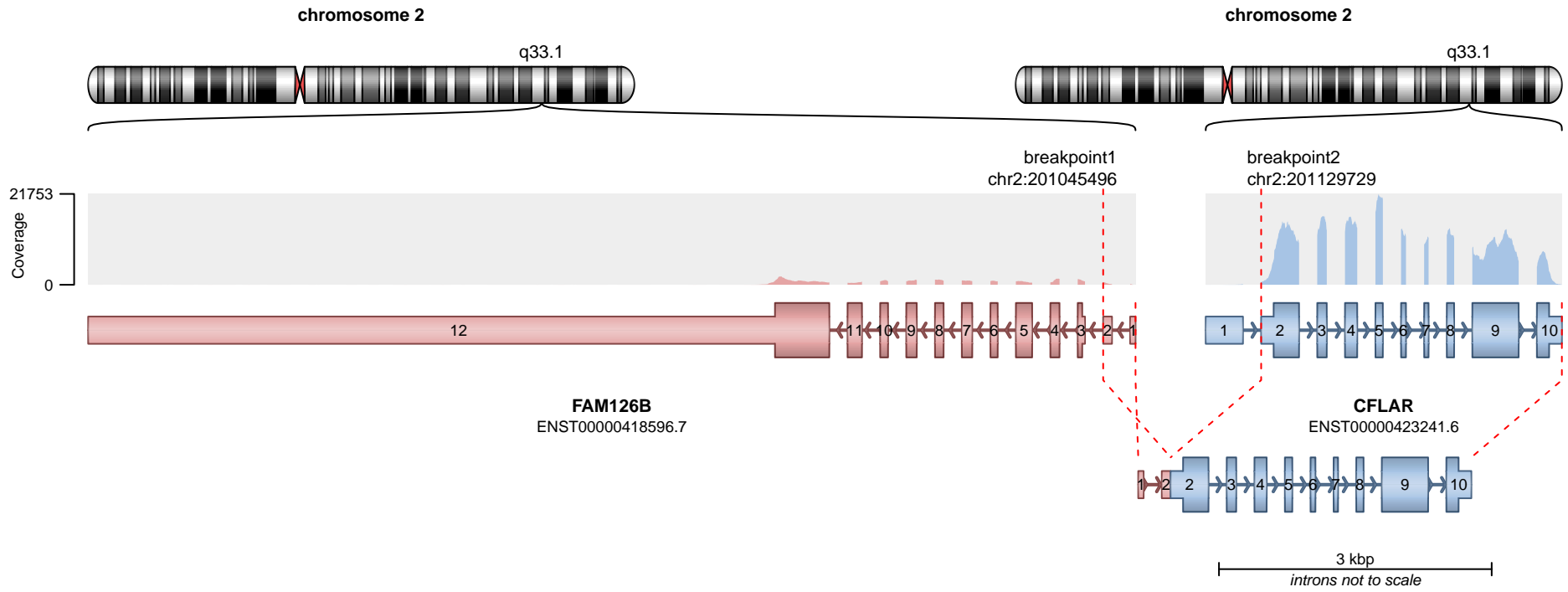

**RETAINED PROTEIN DOMAINS**  
reading frame unclear

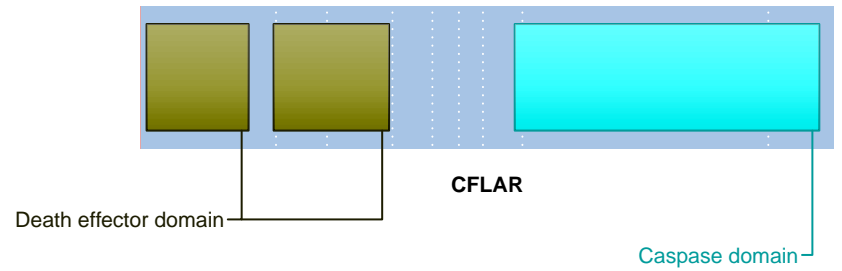

**SUPPORTING READ COUNT**

Split reads = 23  
Discordant mates = 0

- translocation
- duplication
- deletion
- inversion

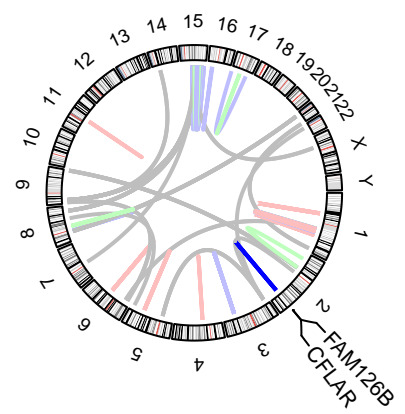
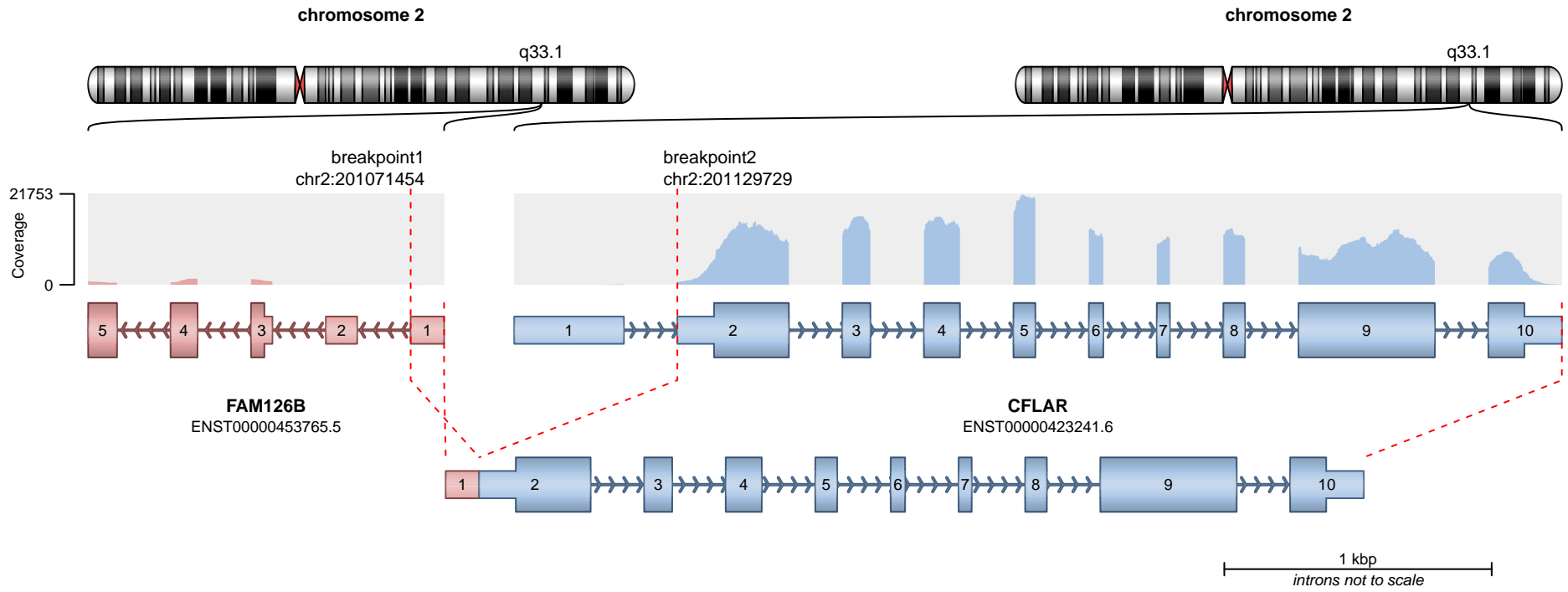

- translocation
- duplication
- deletion
- inversion

**RETAINED PROTEIN DOMAINS**  
reading frame unclear

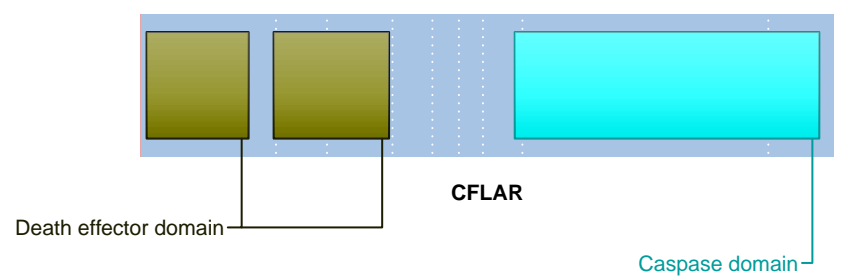

**SUPPORTING READ COUNT**

Split reads = 3  
Discordant mates = 0

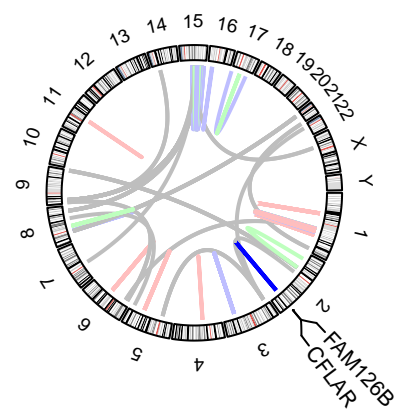
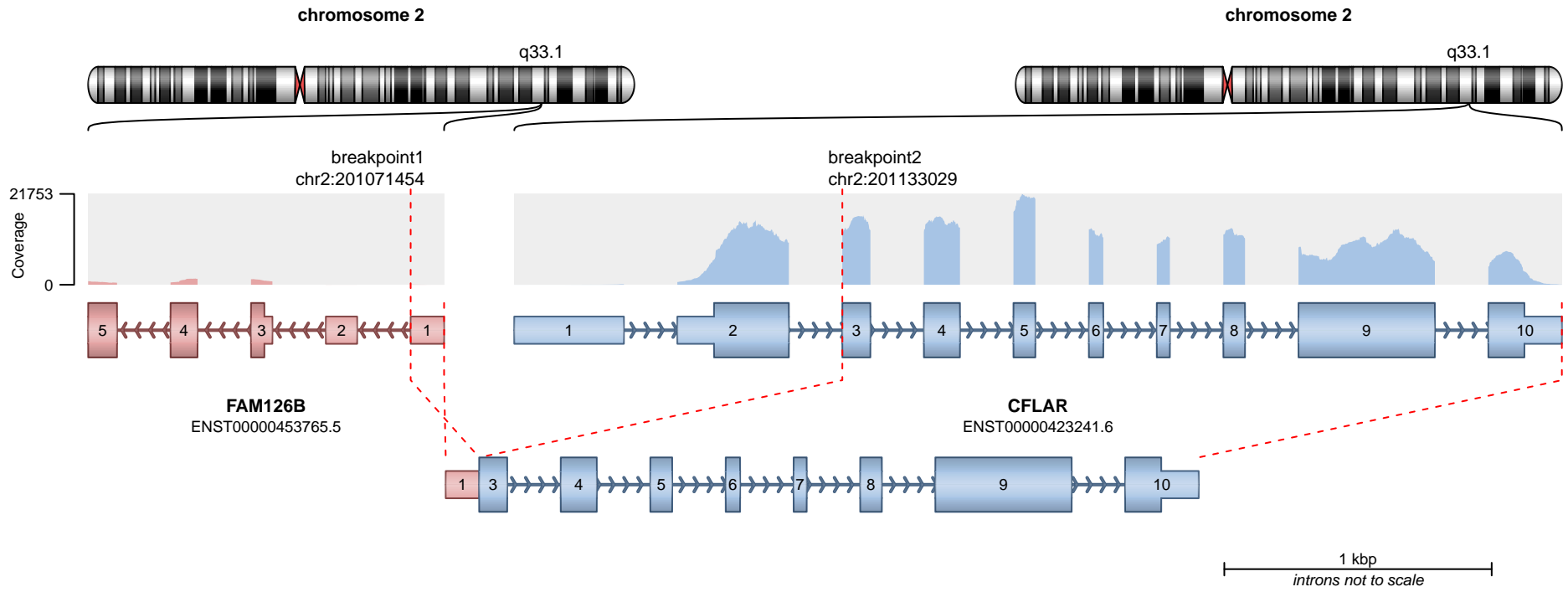

**RETAINED PROTEIN DOMAINS**  
reading frame unclear

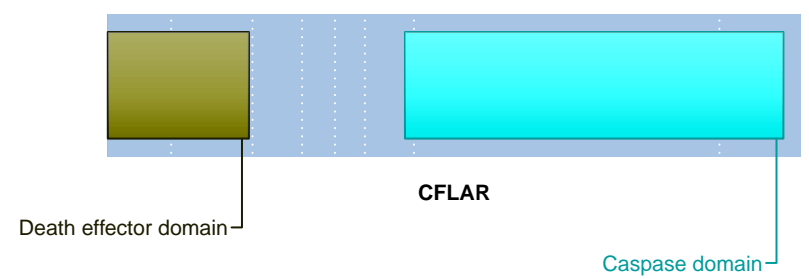

**SUPPORTING READ COUNT**

Split reads = 1  
Discordant mates = 0

- translocation
- duplication
- deletion
- inversion

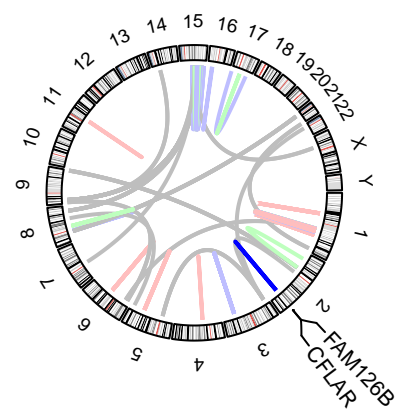
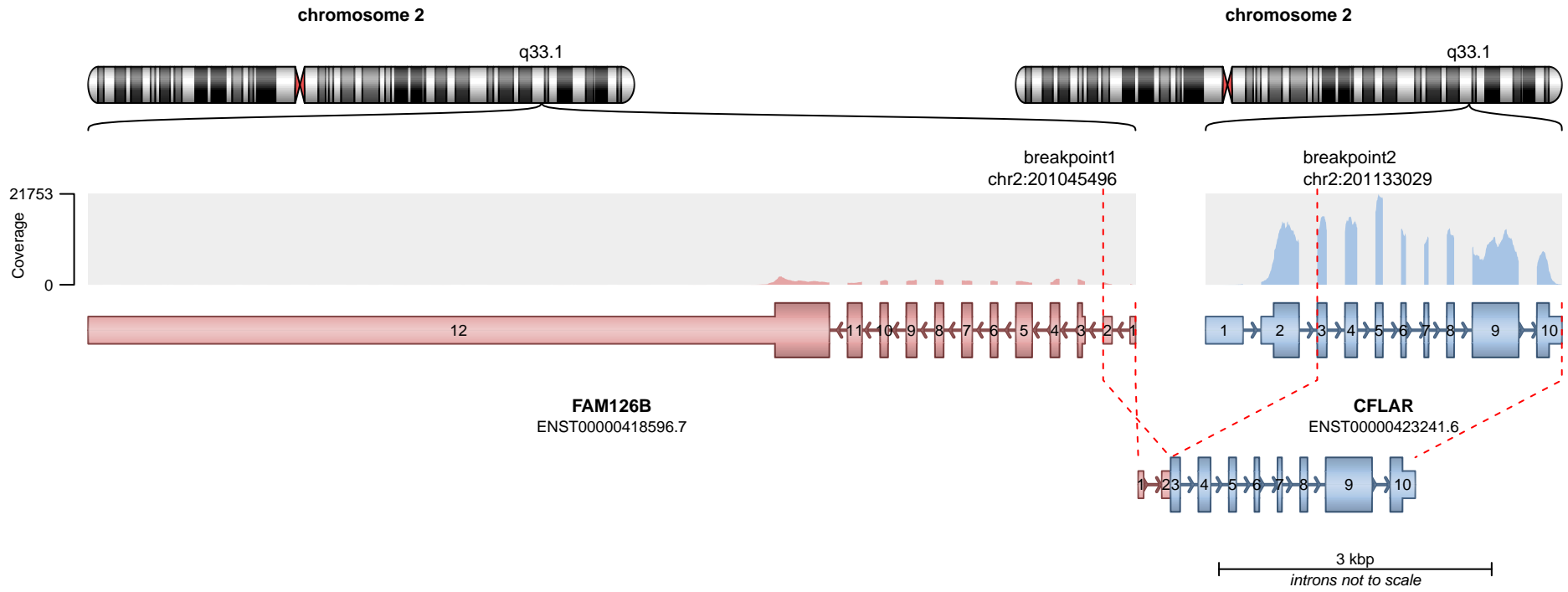

**RETAINED PROTEIN DOMAINS**  
reading frame unclear

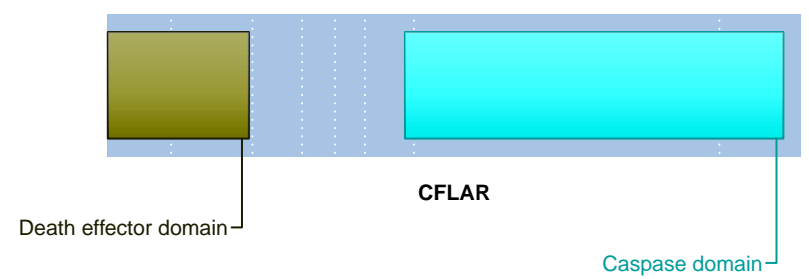

**SUPPORTING READ COUNT**

Split reads = 1  
Discordant mates = 0

- translocation
- duplication
- deletion
- inversion

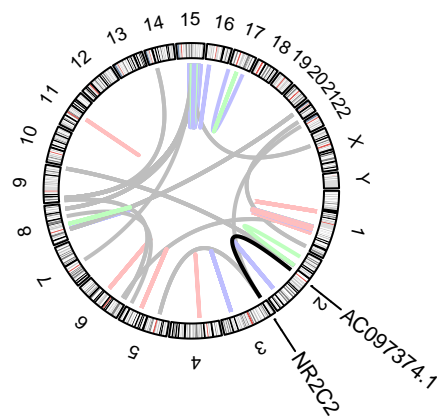
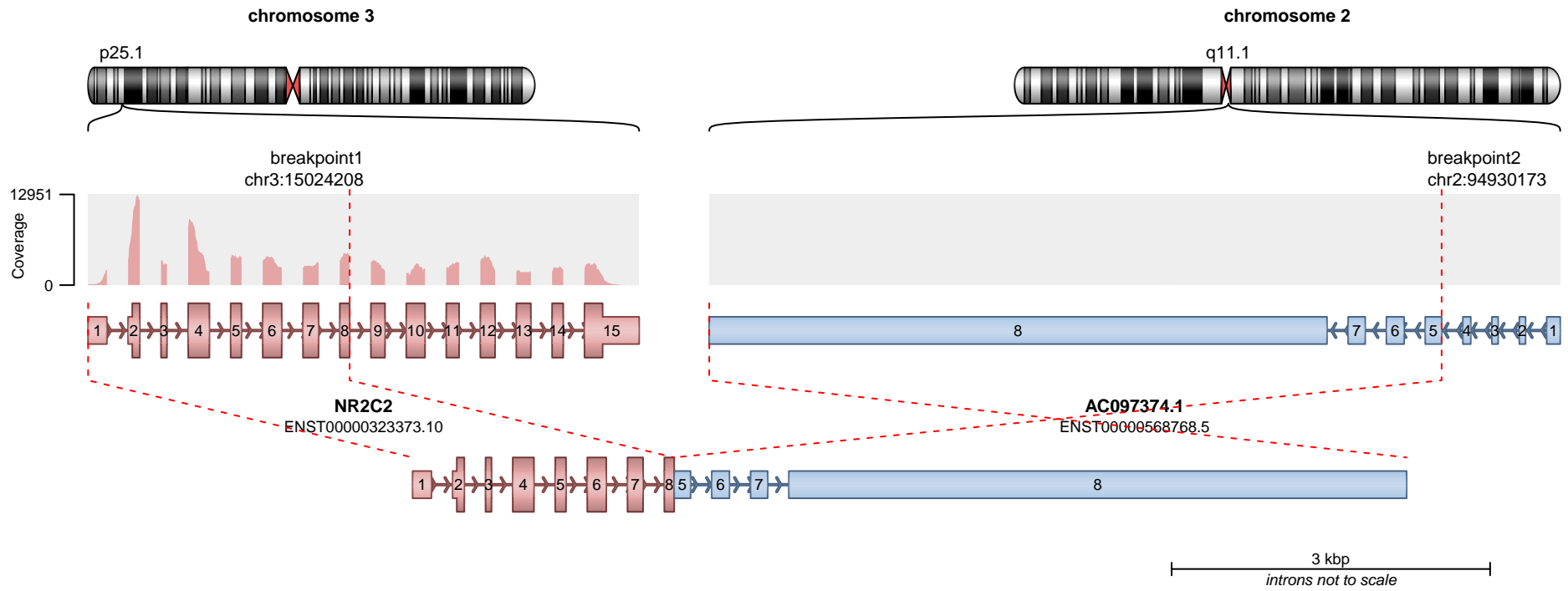

**RETAINED PROTEIN DOMAINS**  
reading frame unclear

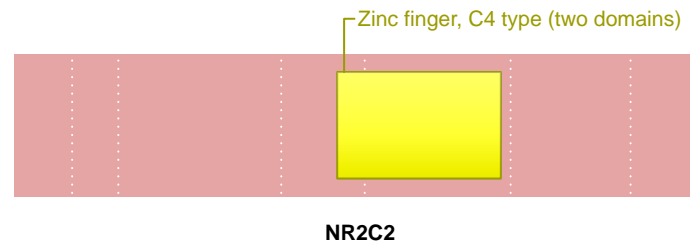

**SUPPORTING READ COUNT**

Split reads = 21  
Discordant mates = 0

- translocation
- duplication
- deletion
- inversion

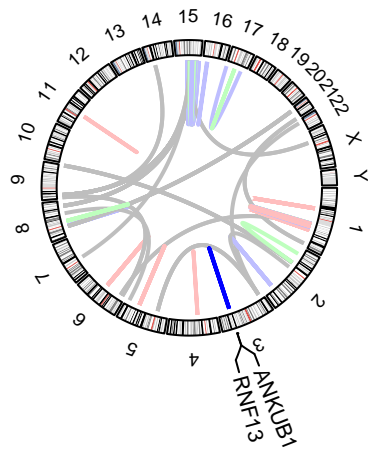
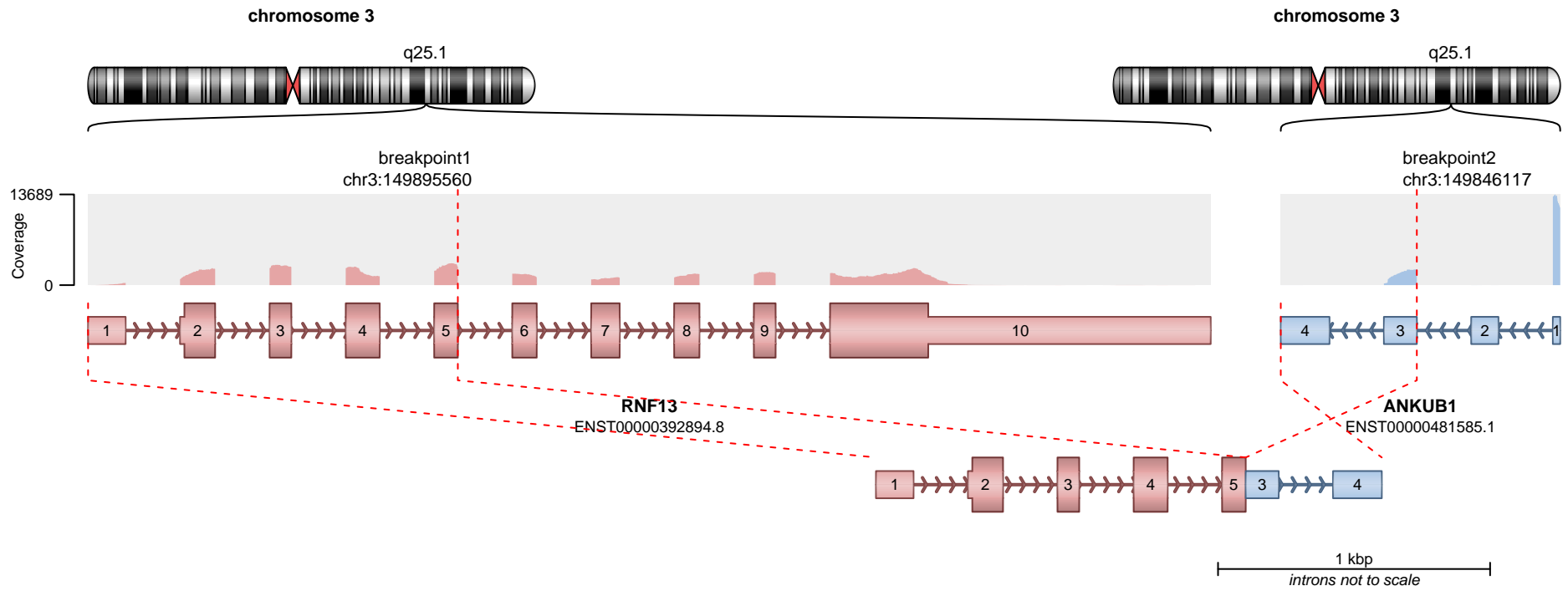

**RETAINED PROTEIN DOMAINS**  
reading frame unclear

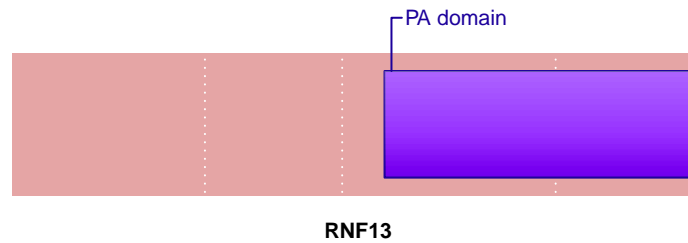

**SUPPORTING READ COUNT**

Split reads = 21  
Discordant mates = 0

- translocation
- duplication
- deletion
- inversion

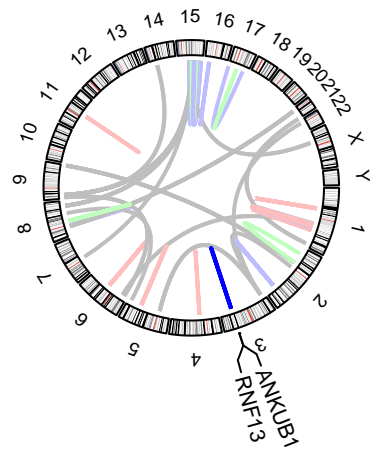
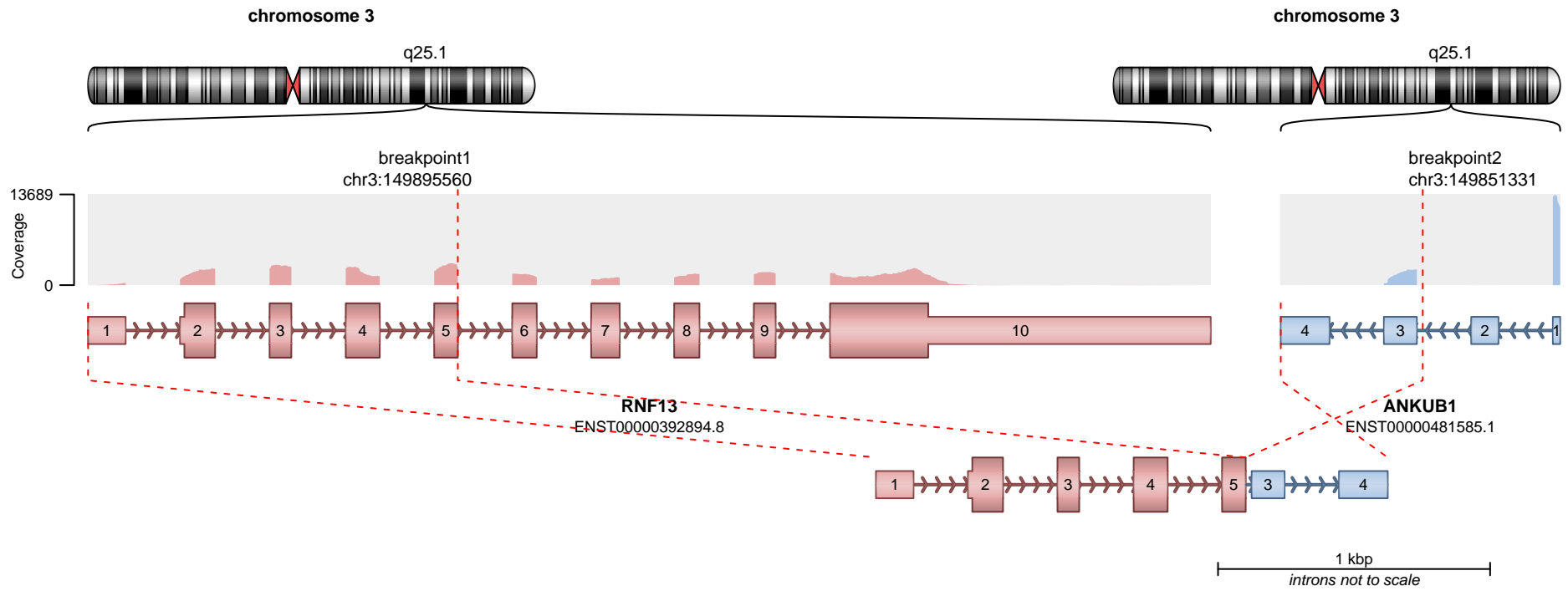

**RETAINED PROTEIN DOMAINS**  
reading frame unclear

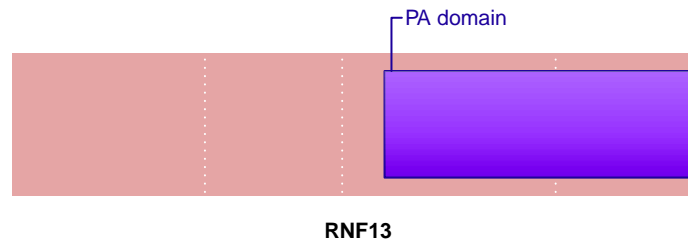

**SUPPORTING READ COUNT**

Split reads = 10  
Discordant mates = 0

- translocation
- duplication
- deletion
- inversion

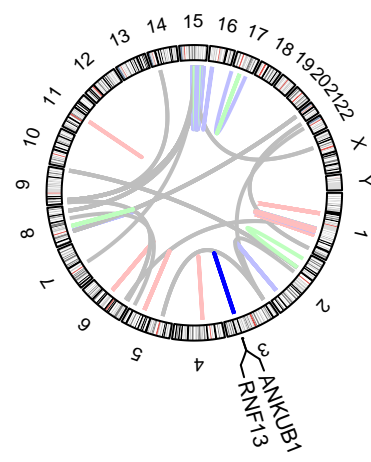
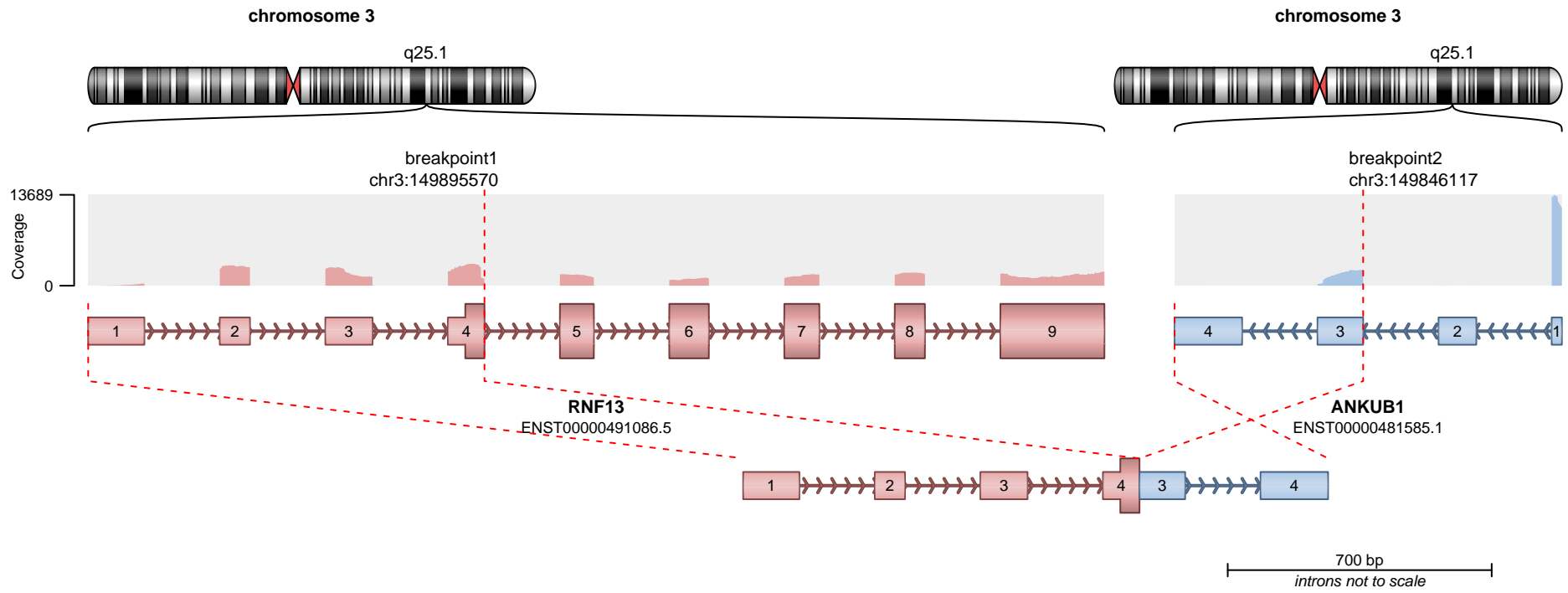

RETAINED PROTEIN DOMAINS  
reading frame unclear

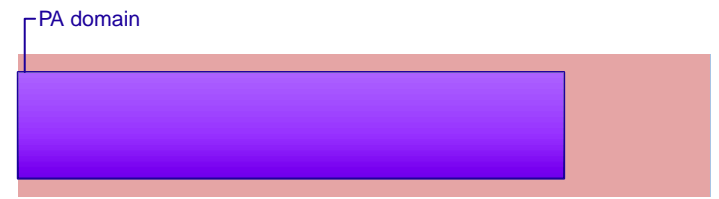

SUPPORTING READ COUNT

Split reads = 5  
Discordant mates = 0

— translocation — deletion  
— duplication — inversion

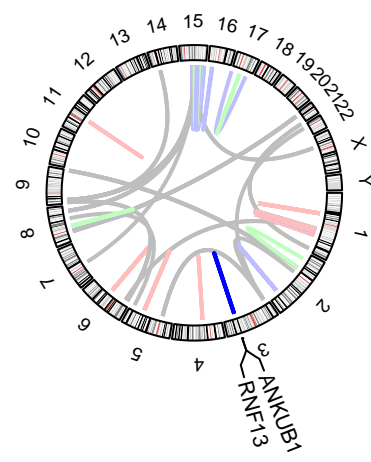
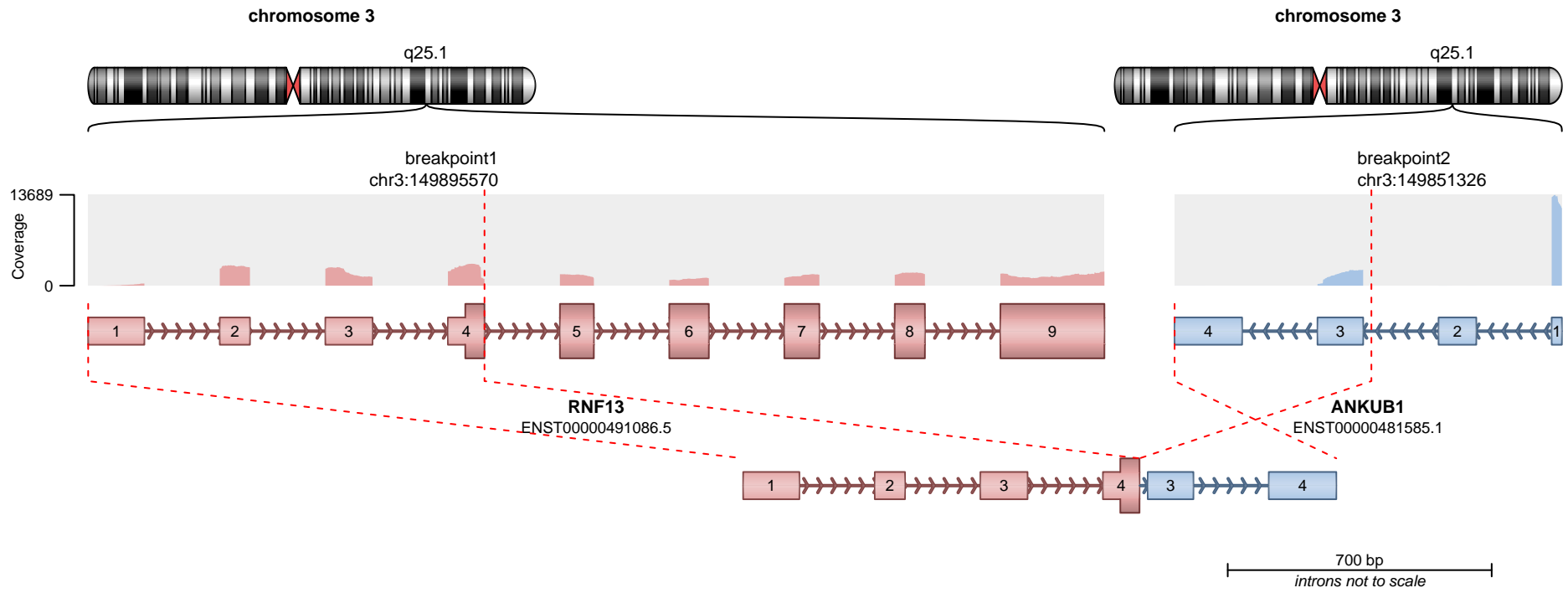

RETAINED PROTEIN DOMAINS  
reading frame unclear

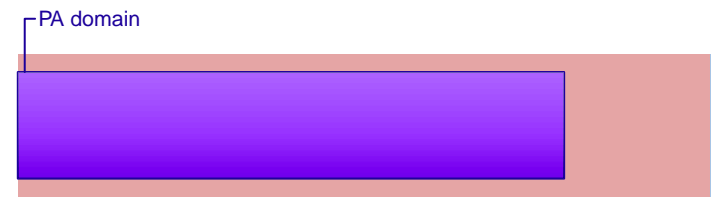

SUPPORTING READ COUNT

Split reads = 3  
Discordant mates = 0

- translocation
- duplication
- deletion
- inversion

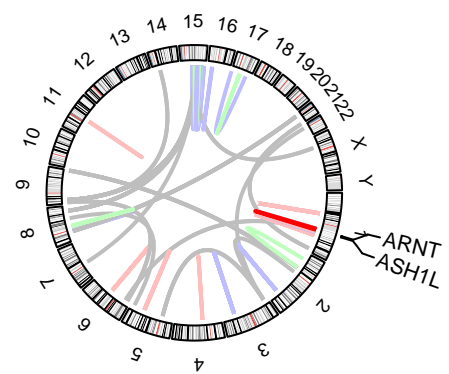
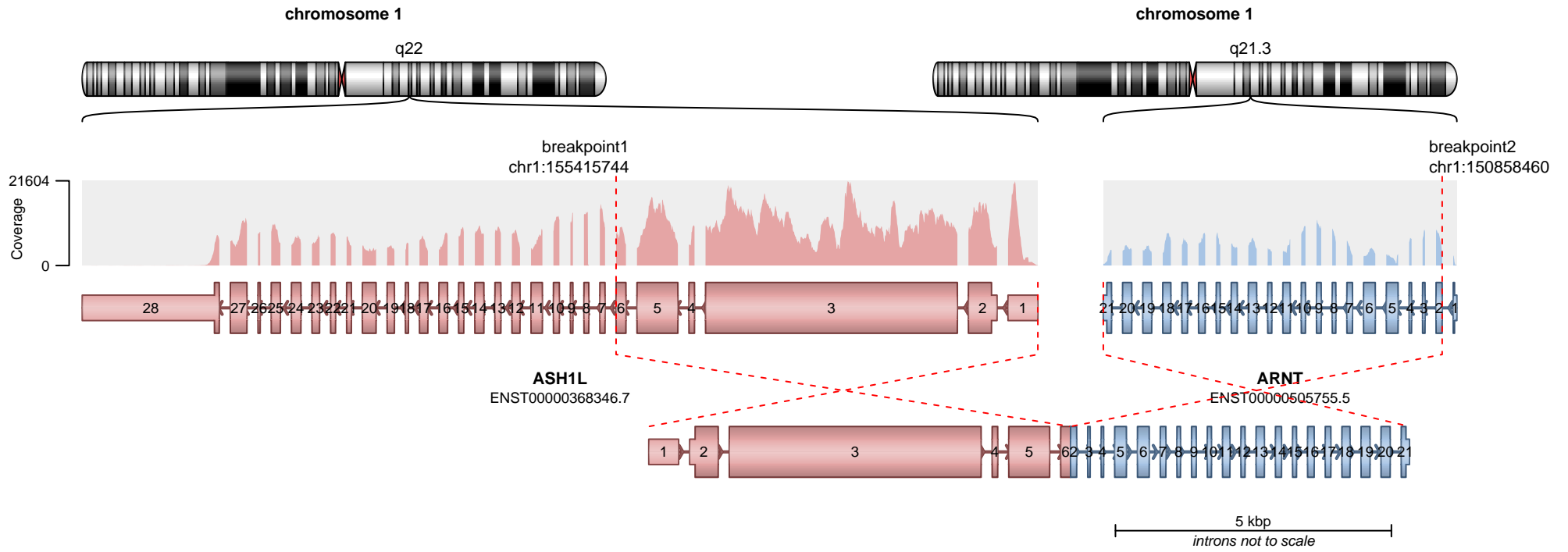

**RETAINED PROTEIN DOMAINS**  
reading frame unclear

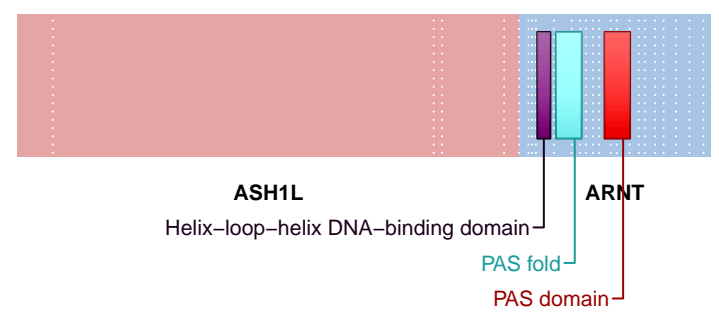

**SUPPORTING READ COUNT**

Split reads = 20  
Discordant mates = 0

- translocation
- duplication
- deletion
- inversion

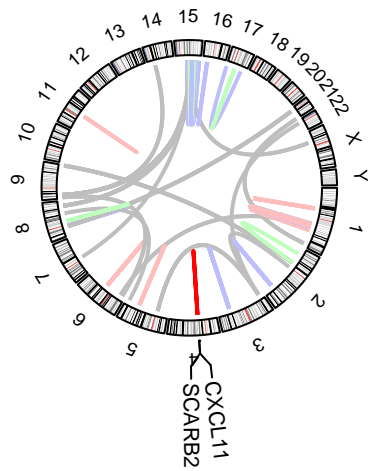
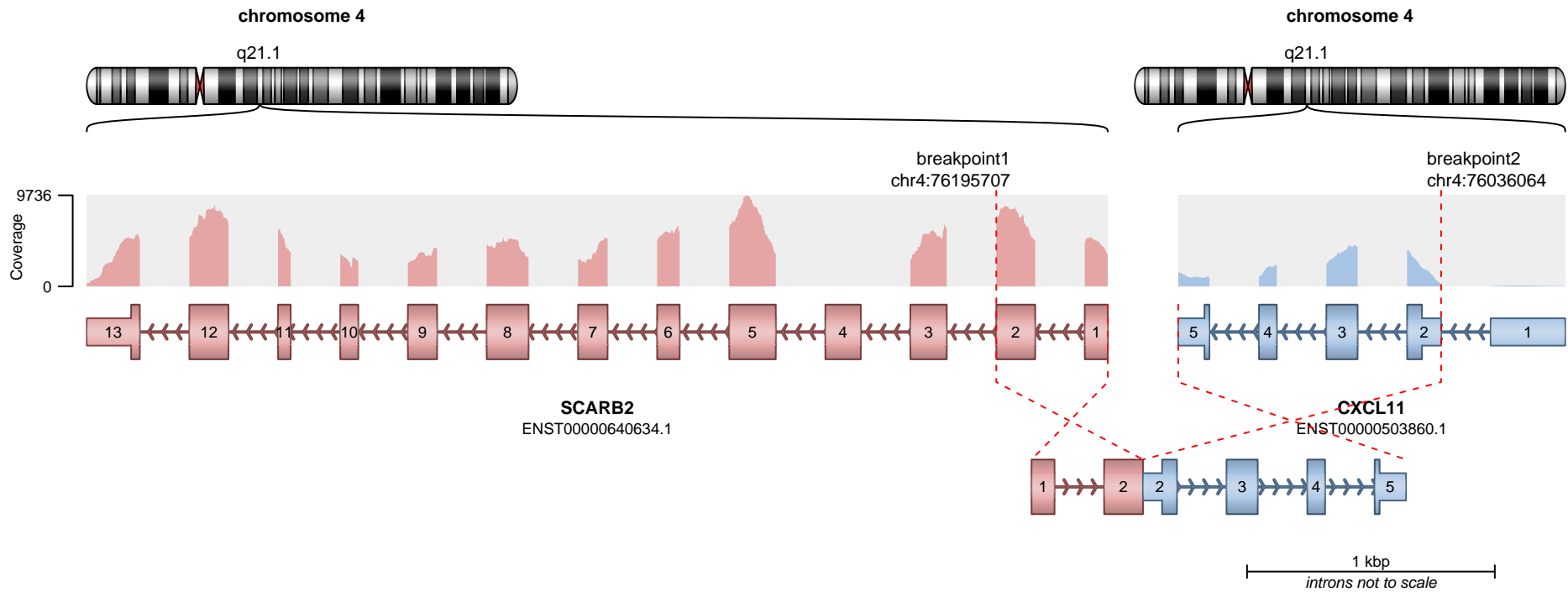

**RETAINED PROTEIN DOMAINS**  
reading frame unclear

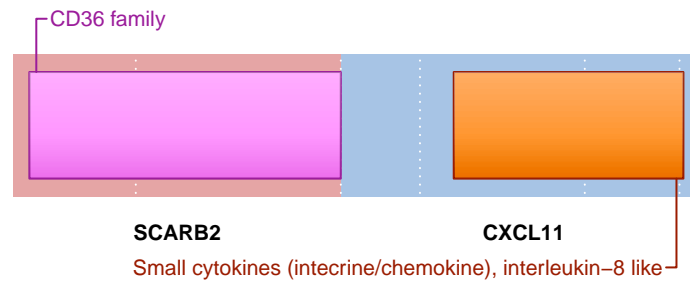

**SUPPORTING READ COUNT**

Split reads = 19  
Discordant mates = 0

- translocation
- duplication
- deletion
- inversion

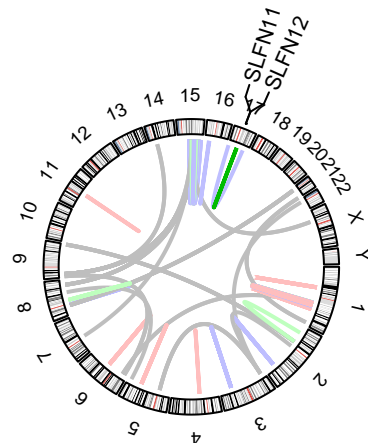
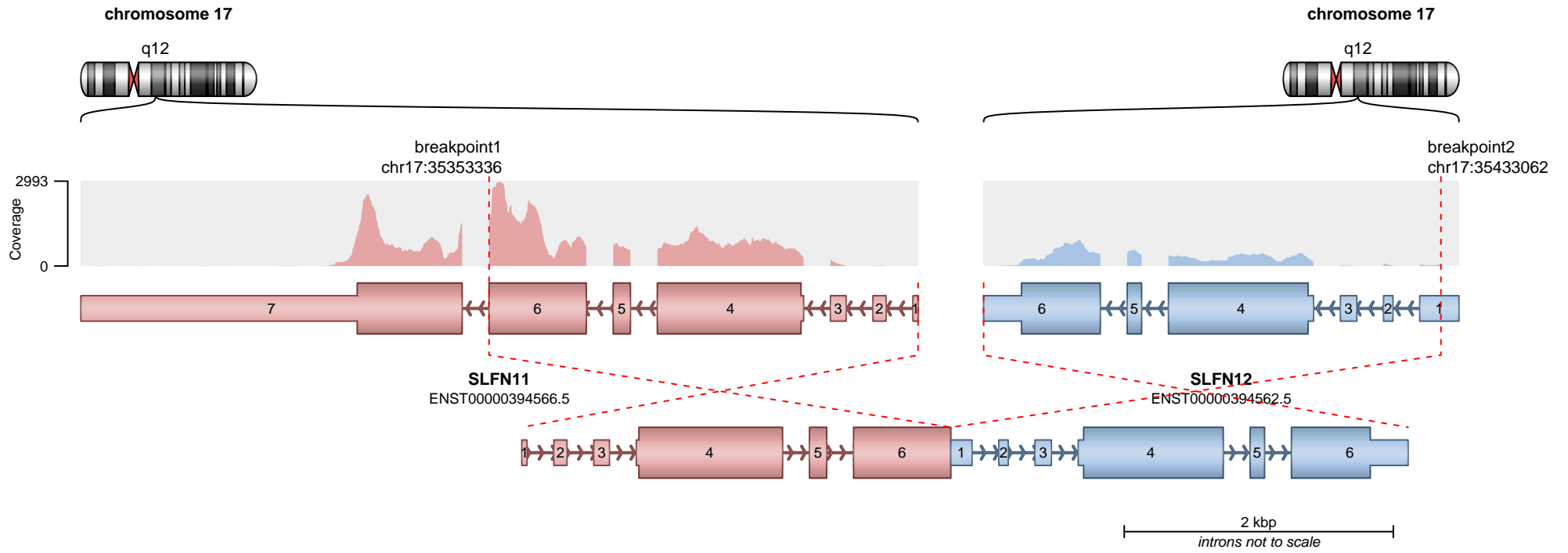

**RETAINED PROTEIN DOMAINS**  
reading frame unclear

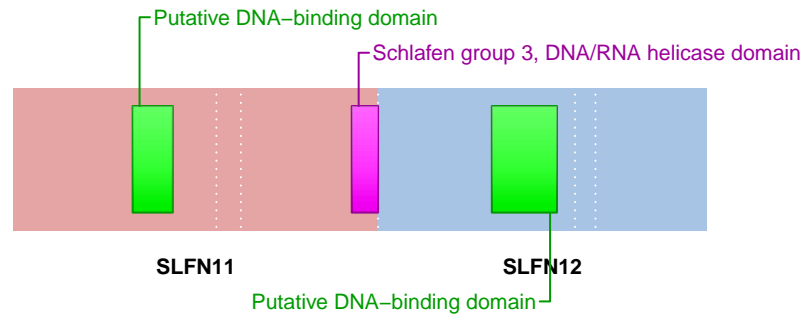

**SUPPORTING READ COUNT**

Split reads = 19  
Discordant mates = 0

— translocation — deletion  
— duplication — inversion

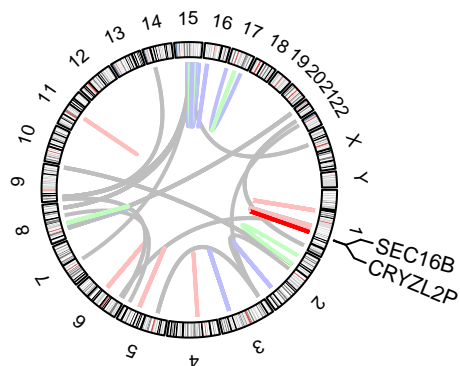
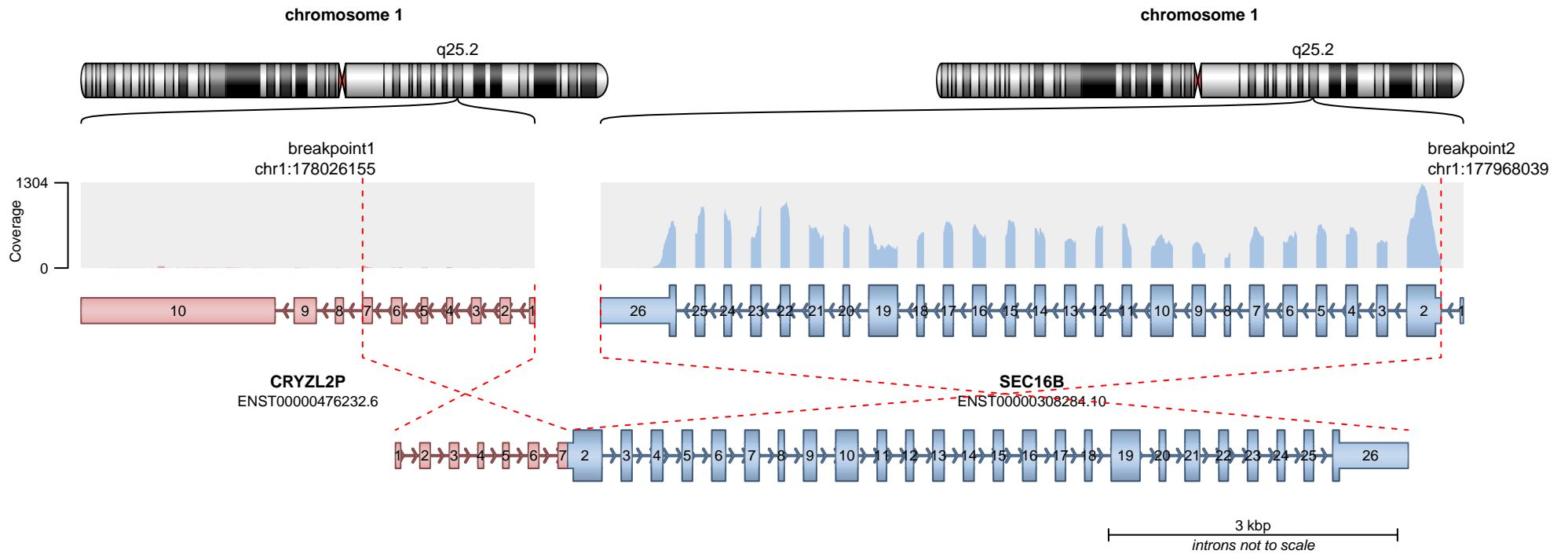

**RETAINED PROTEIN DOMAINS**  
reading frame unclear

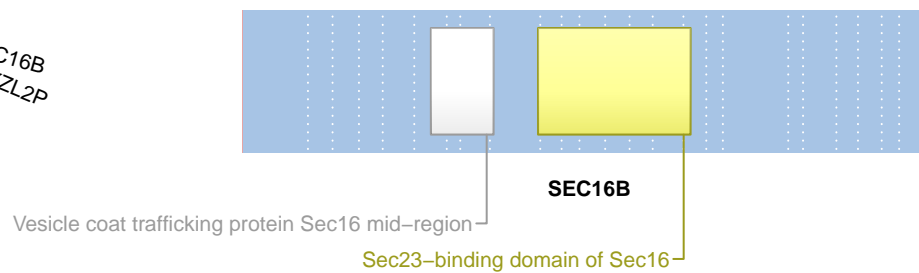

**SUPPORTING READ COUNT**

Split reads = 17  
Discordant mates = 1

- translocation
- duplication
- deletion
- inversion

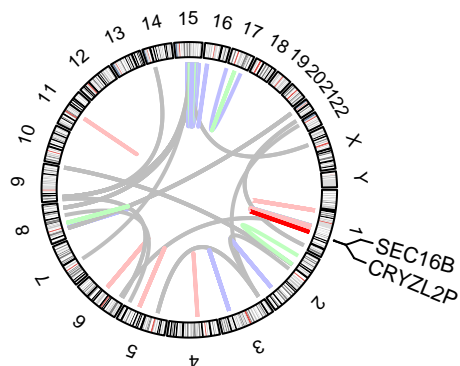
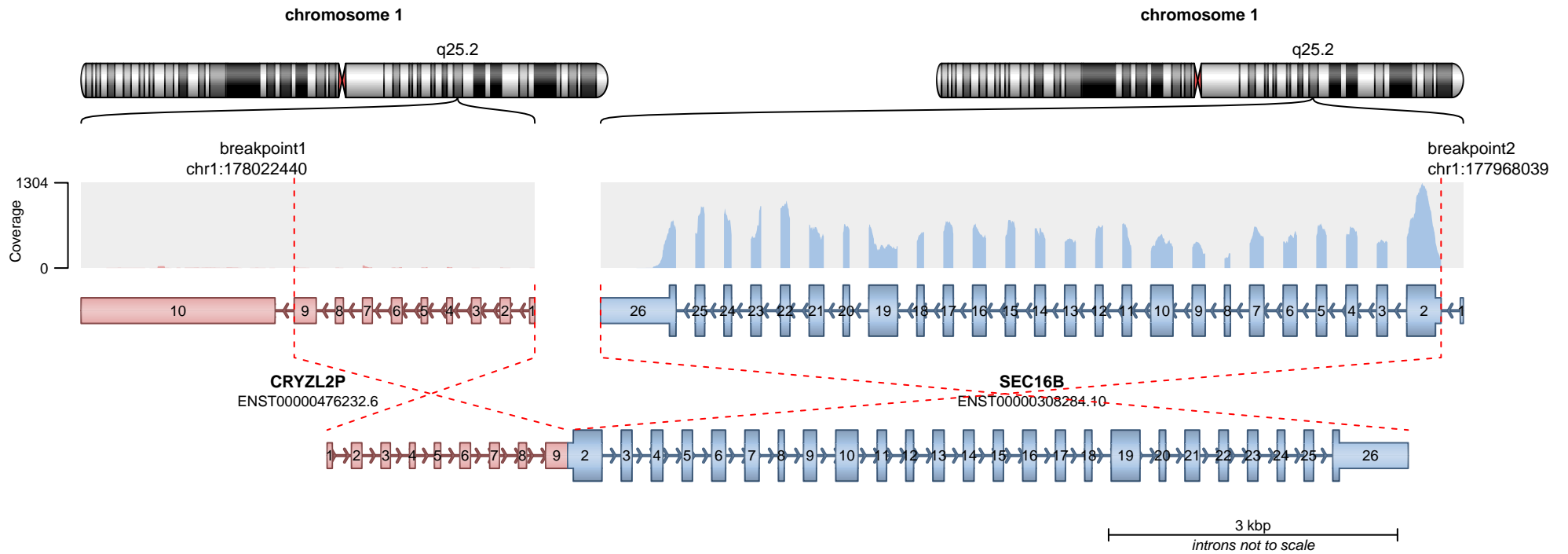

**RETAINED PROTEIN DOMAINS**  
reading frame unclear



**SUPPORTING READ COUNT**

Split reads = 2  
Discordant mates = 1

- translocation
- duplication
- deletion
- inversion

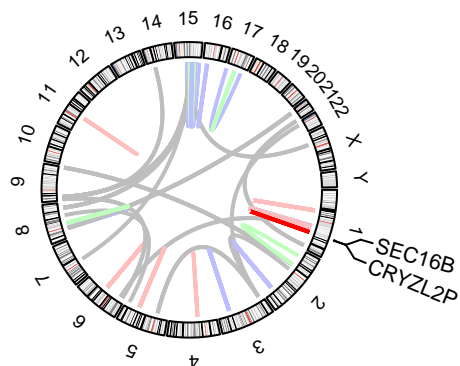
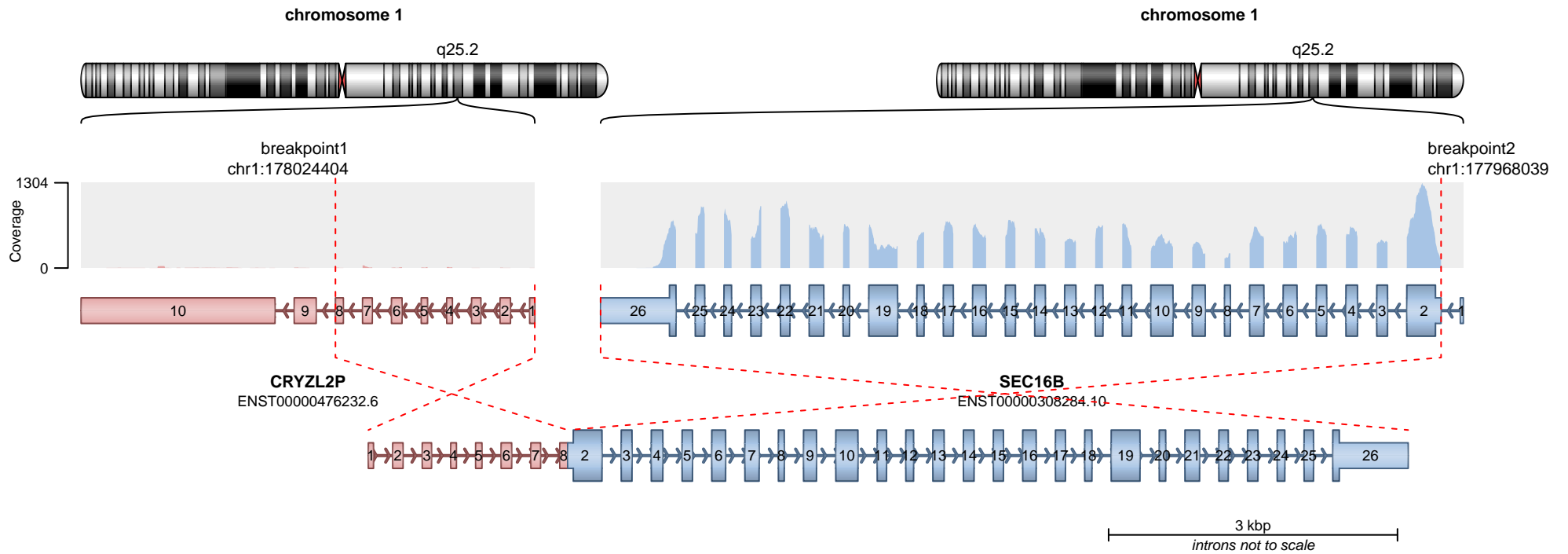

**RETAINED PROTEIN DOMAINS**  
reading frame unclear

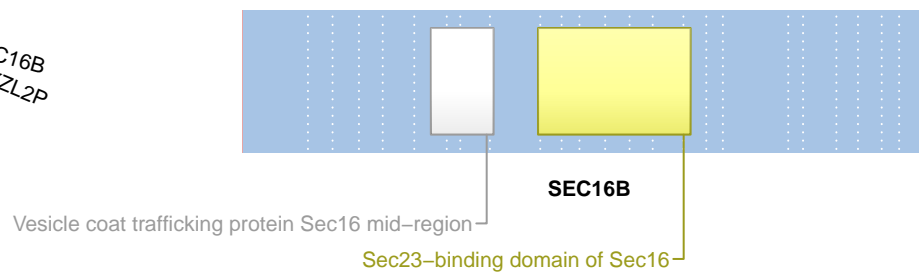

**SUPPORTING READ COUNT**

Split reads = 2  
Discordant mates = 1

- translocation
- duplication
- deletion
- inversion

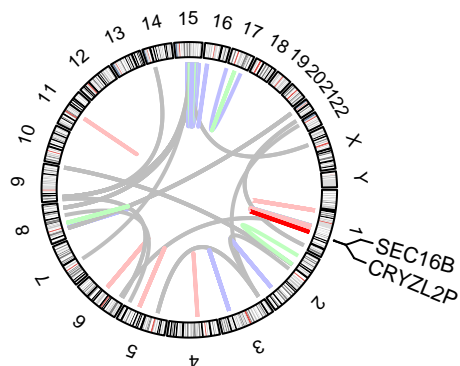
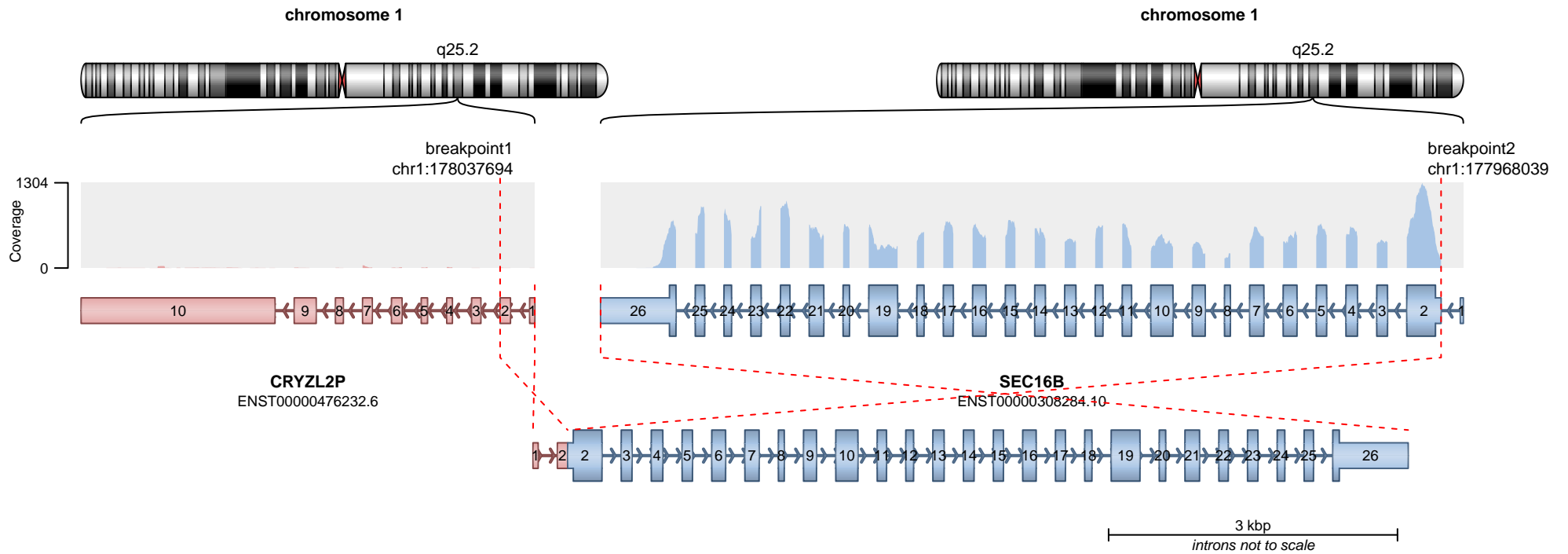

**RETAINED PROTEIN DOMAINS**  
reading frame unclear



Vesicle coat trafficking protein Sec16 mid-region

Sec23-binding domain of Sec16

**SUPPORTING READ COUNT**

Split reads = 2  
Discordant mates = 0

- translocation
- duplication
- deletion
- inversion

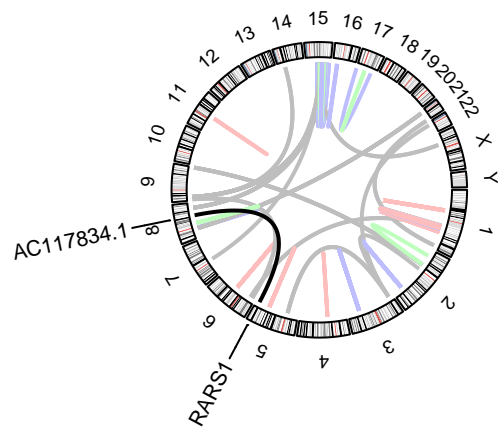
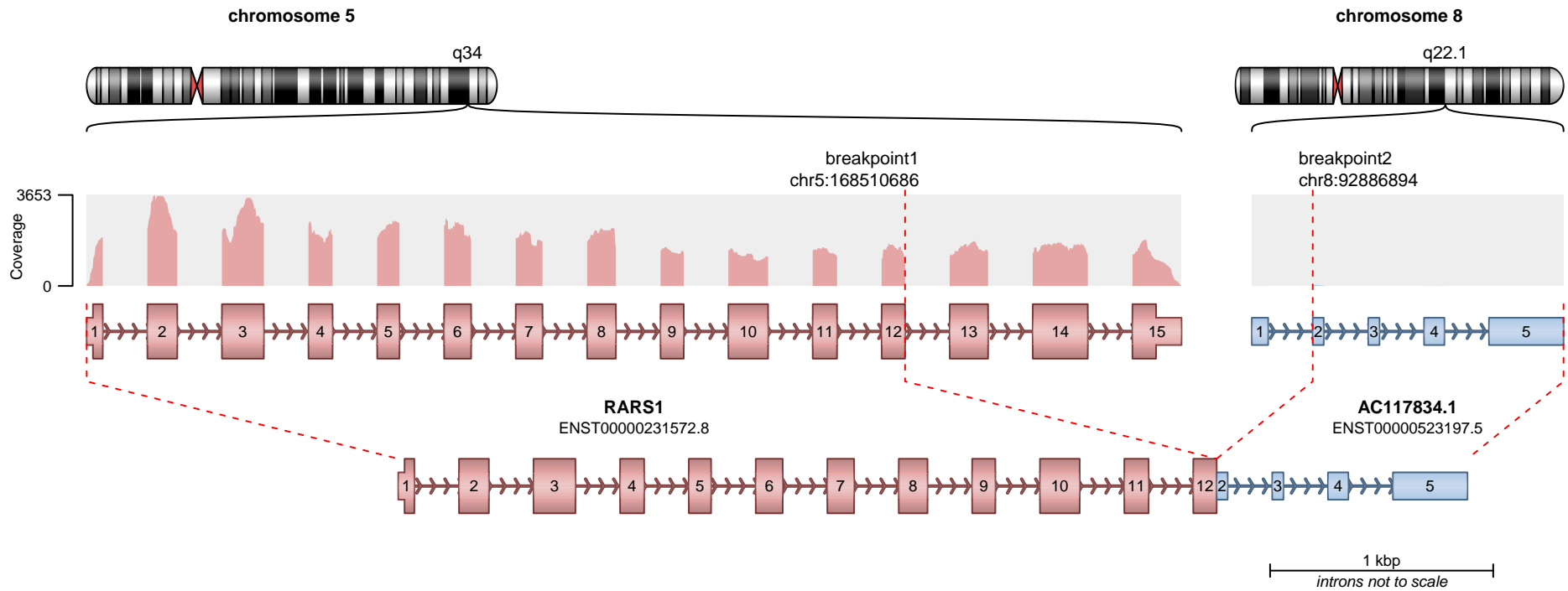

**RETAINED PROTEIN DOMAINS**  
reading frame unclear

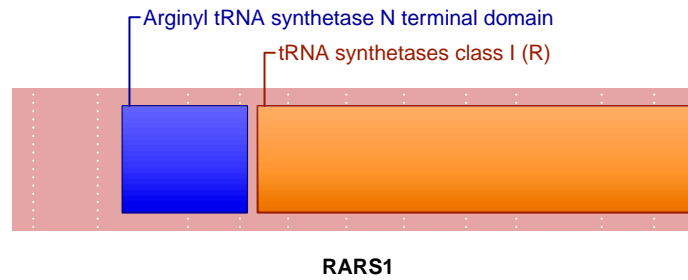

**SUPPORTING READ COUNT**

Split reads = 15  
Discordant mates = 0

- translocation
- duplication
- deletion
- inversion

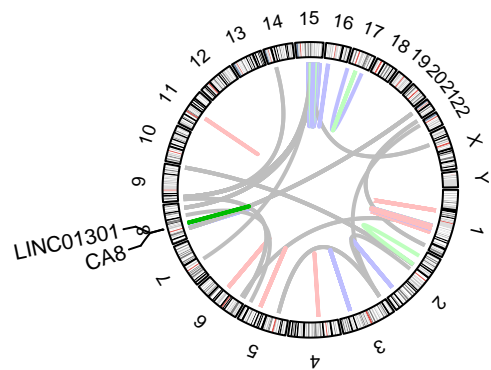
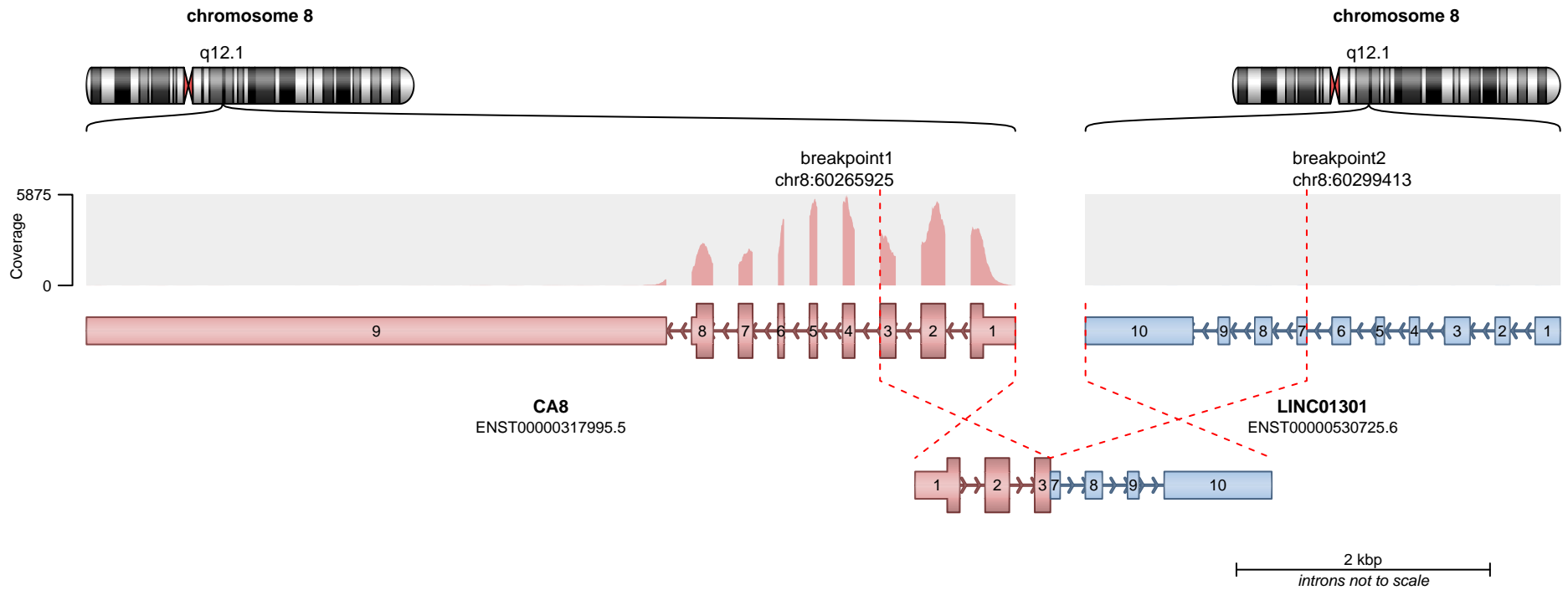

**RETAINED PROTEIN DOMAINS**  
reading frame unclear

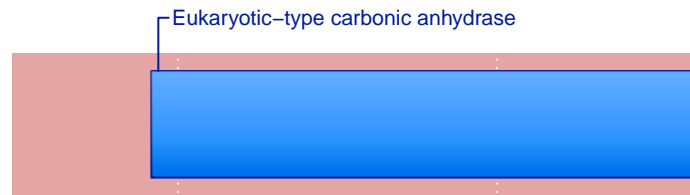

**CA8**

**SUPPORTING READ COUNT**

Split reads = 14  
Discordant mates = 0

— translocation    — deletion  
— duplication    — inversion

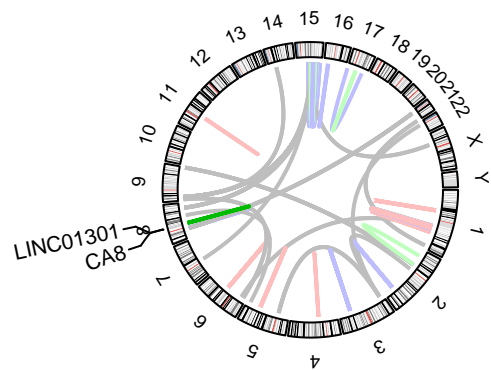
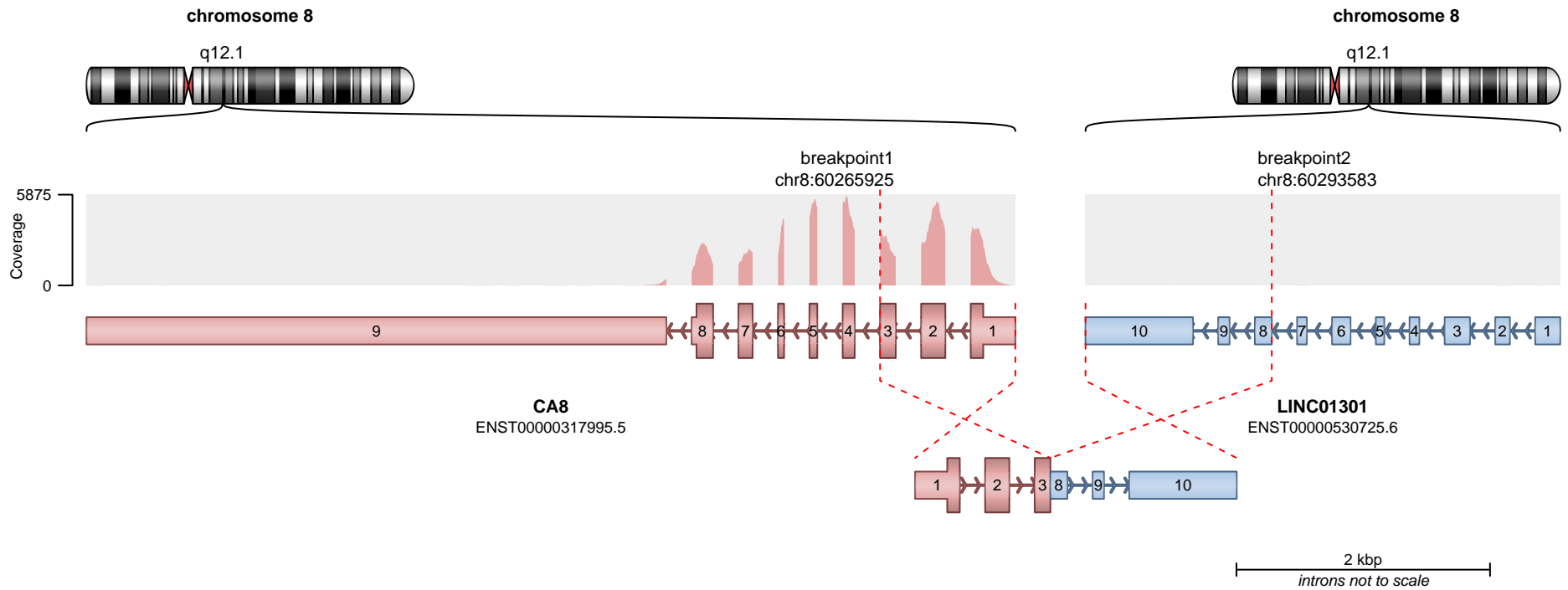

**RETAINED PROTEIN DOMAINS**  
reading frame unclear

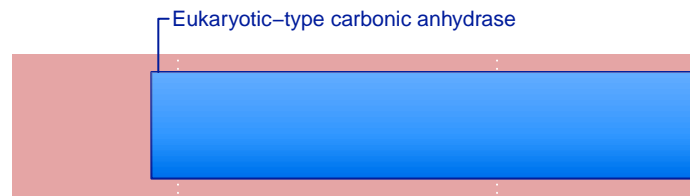

CA8

**SUPPORTING READ COUNT**

Split reads = 1  
Discordant mates = 0

- translocation
- duplication
- deletion
- inversion

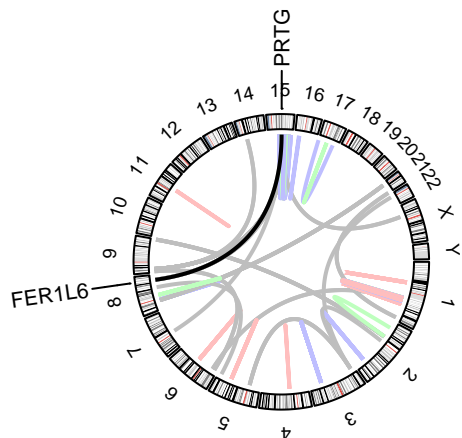
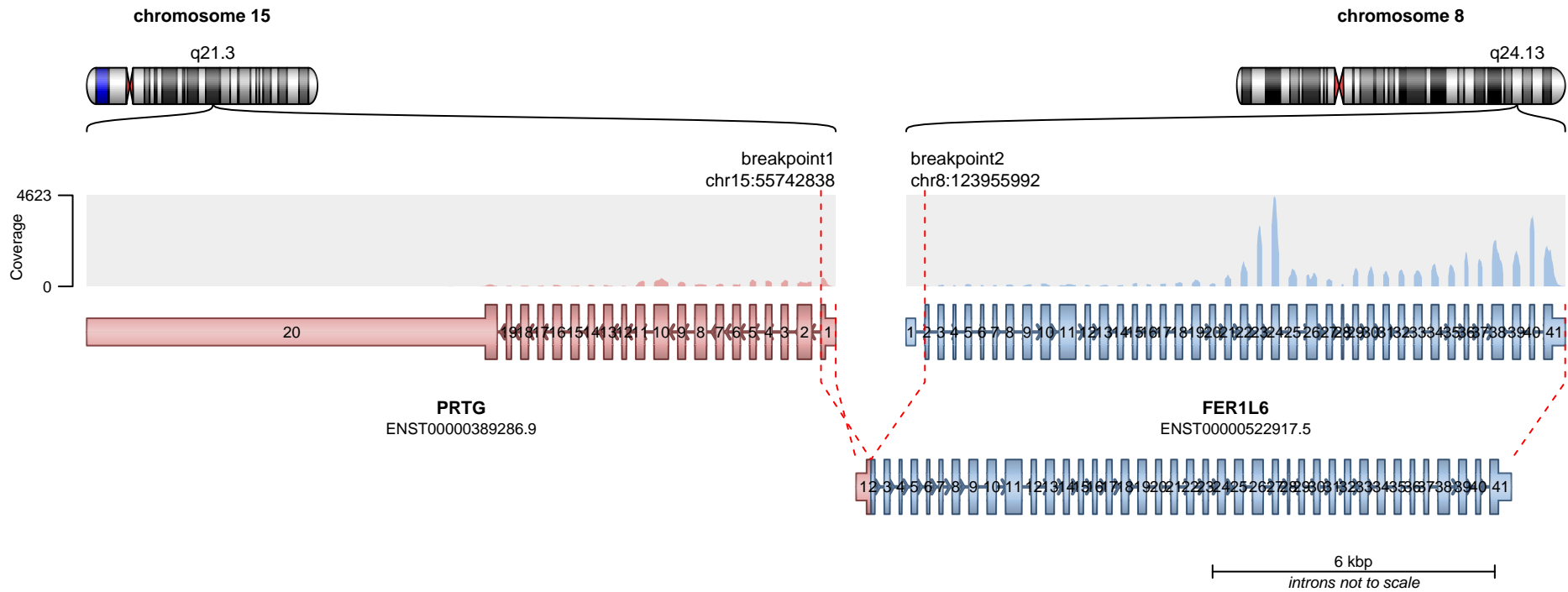

— translocation    — deletion  
 — duplication    — inversion

**RETAINED PROTEIN DOMAINS**  
reading frame unclear

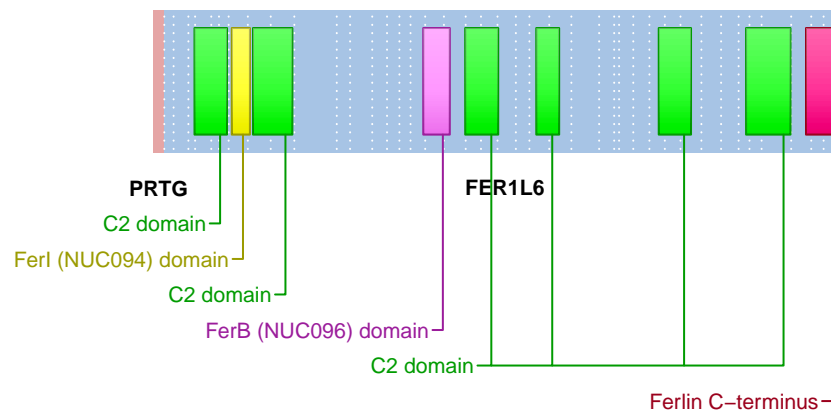

**SUPPORTING READ COUNT**

Split reads = 12  
Discordant mates = 0

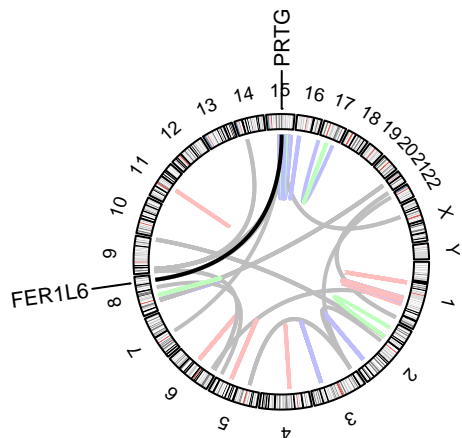
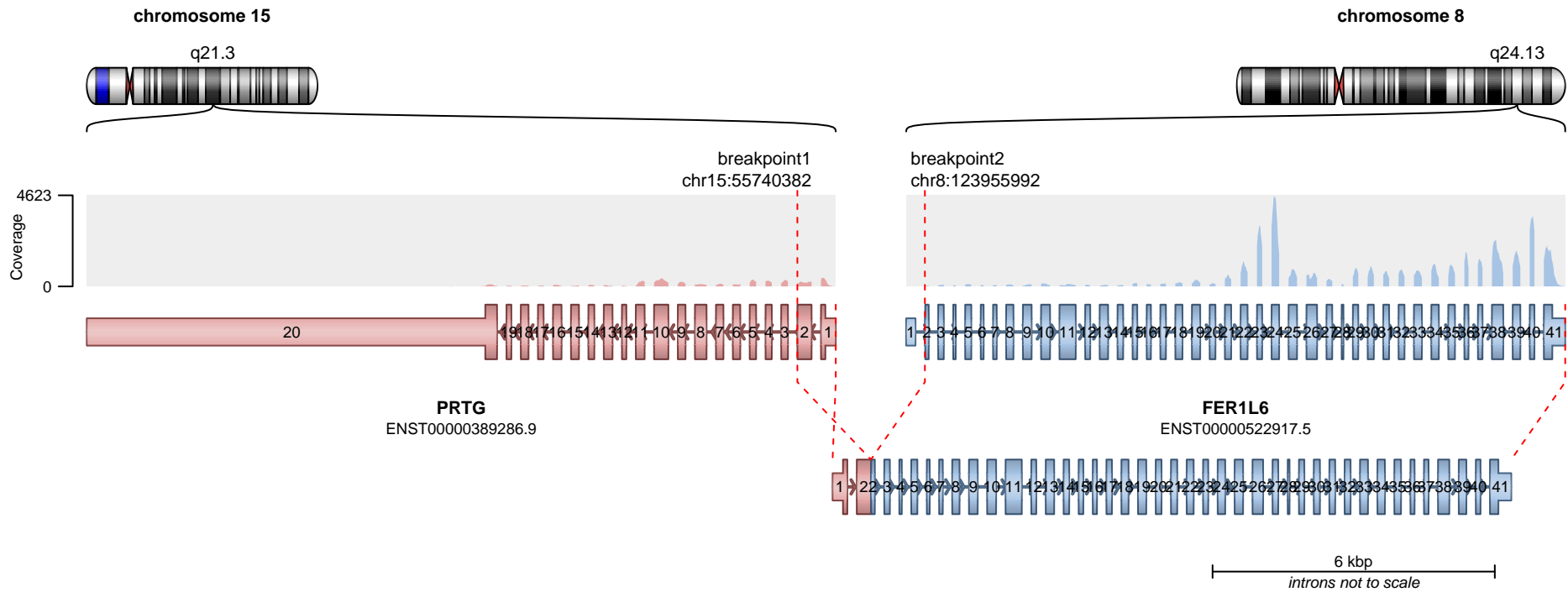

— translocation    — deletion  
 — duplication    — inversion

**RETAINED PROTEIN DOMAINS**  
reading frame unclear

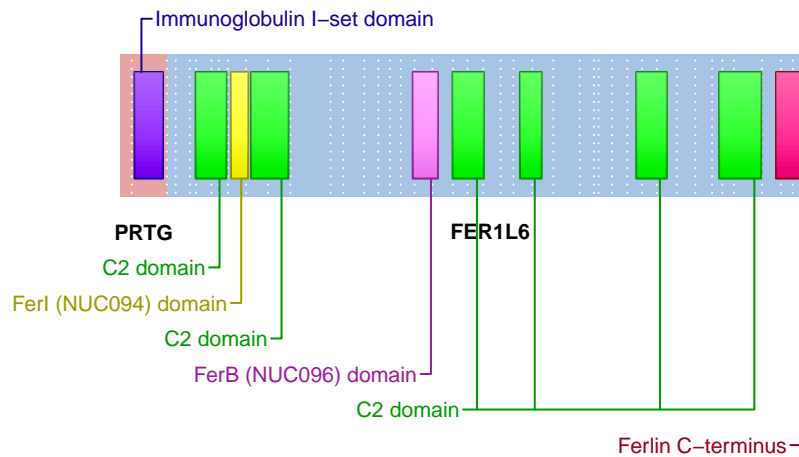

**SUPPORTING READ COUNT**

Split reads = 7  
 Discordant mates = 0

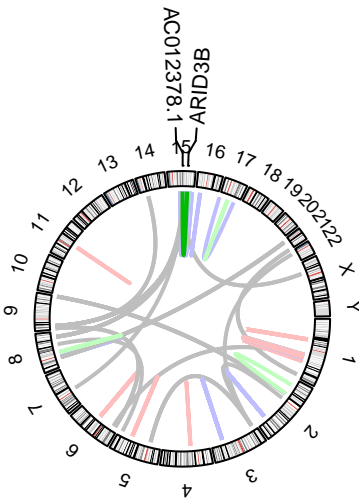
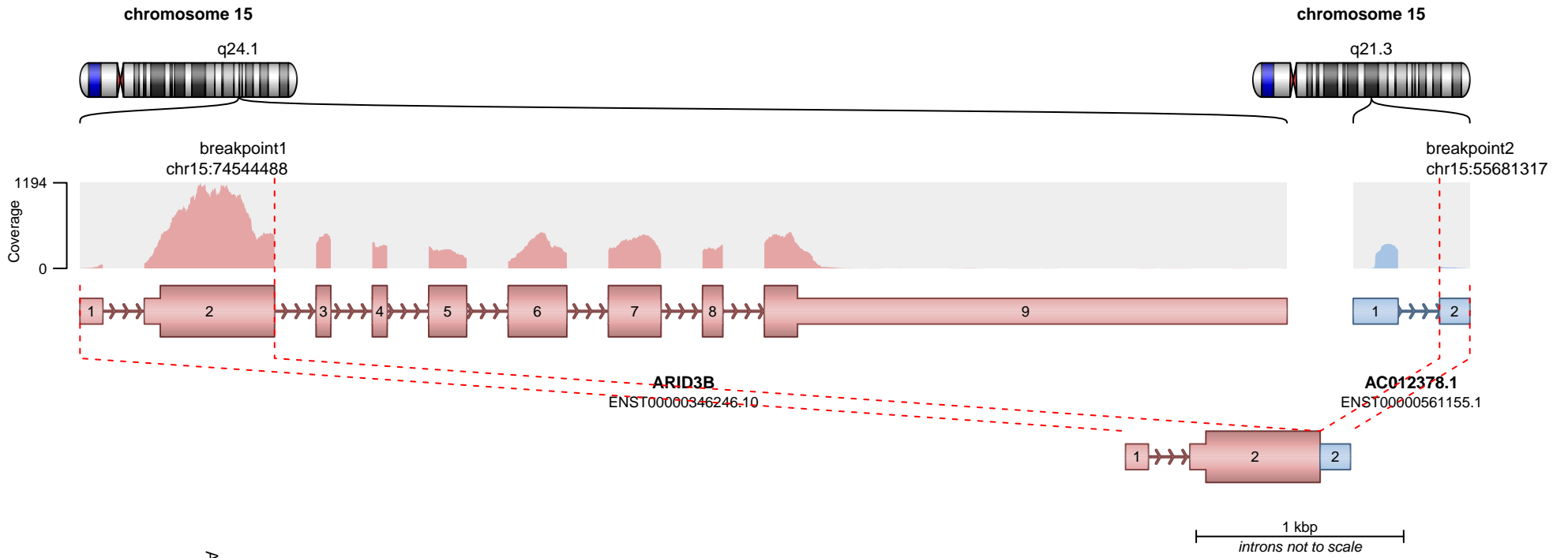

No protein domains retained in fusion.

**SUPPORTING READ COUNT**

Split reads = 11  
Discordant mates = 0

- translocation
- duplication
- deletion
- inversion

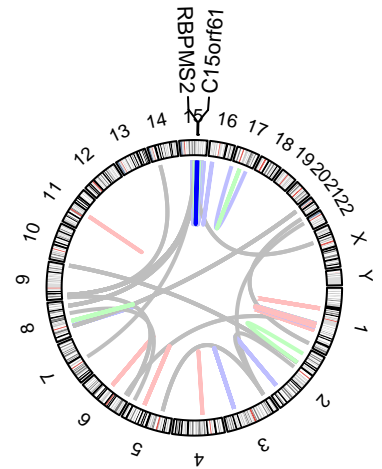
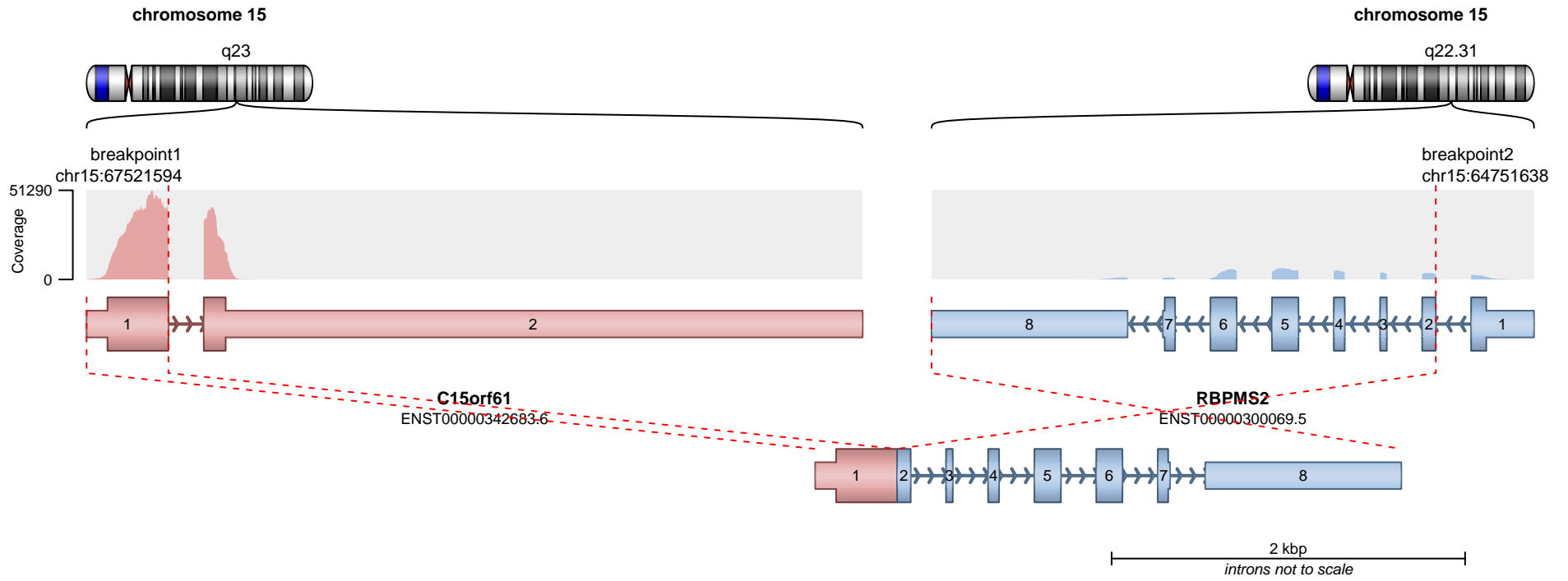

**RETAINED PROTEIN DOMAINS**  
reading frame unclear

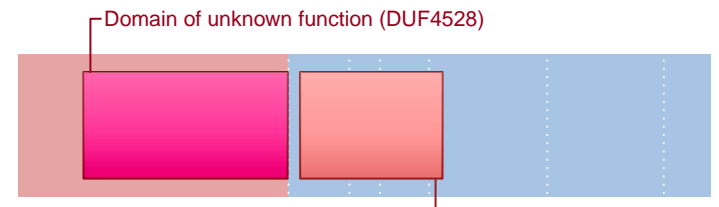

**SUPPORTING READ COUNT**

Split reads = 11  
Discordant mates = 0

- translocation
- duplication
- deletion
- inversion

RNA recognition motif. (a.k.a. RRM, RBD, or RNP domain)

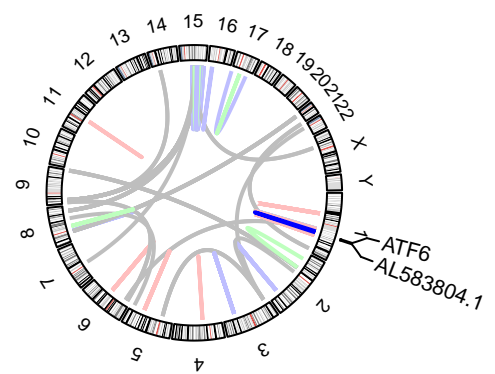
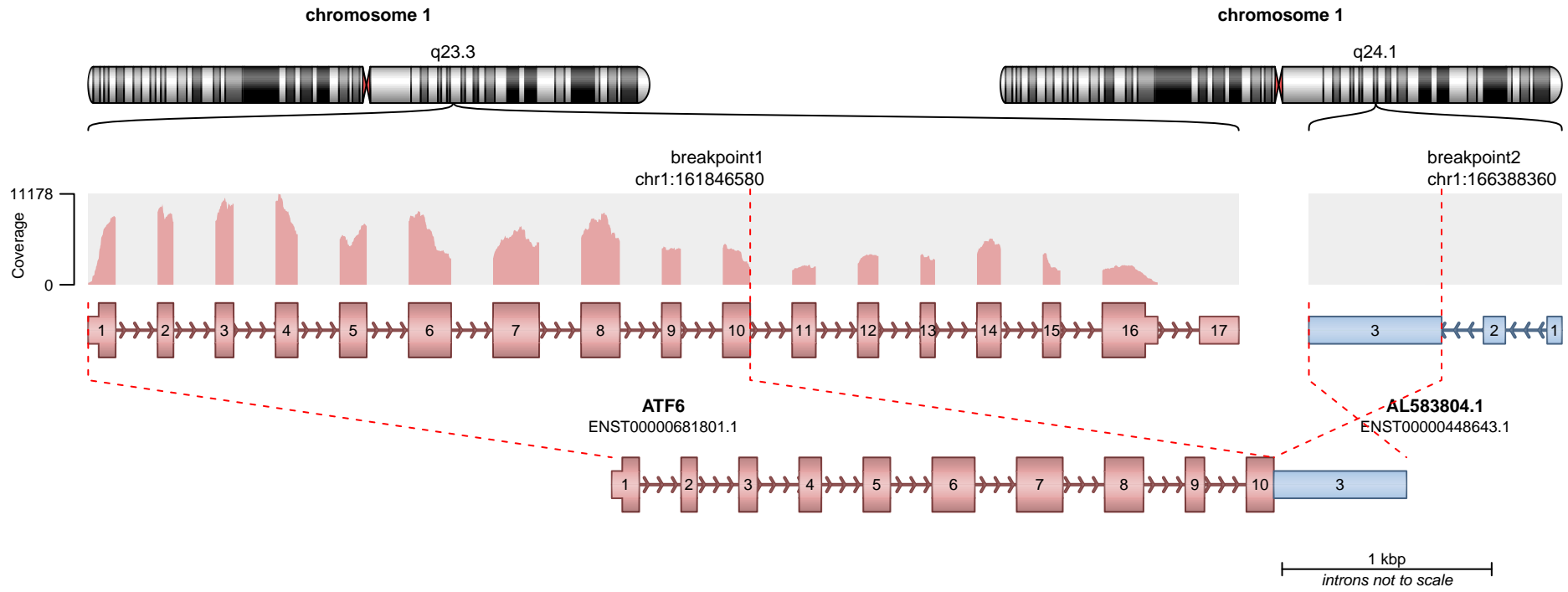

RETAINED PROTEIN DOMAINS  
reading frame unclear

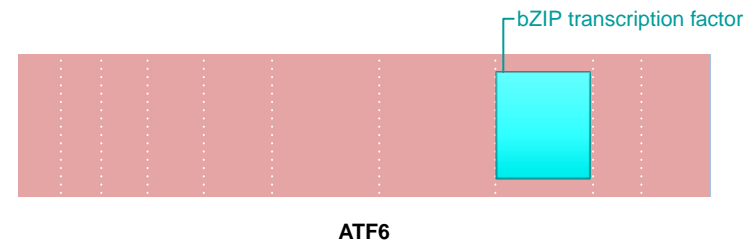

SUPPORTING READ COUNT

Split reads = 2  
Discordant mates = 0

- translocation
- duplication
- deletion
- inversion

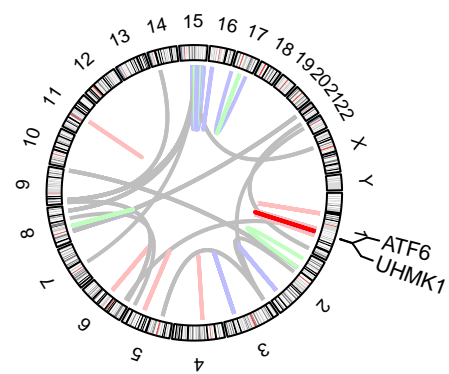
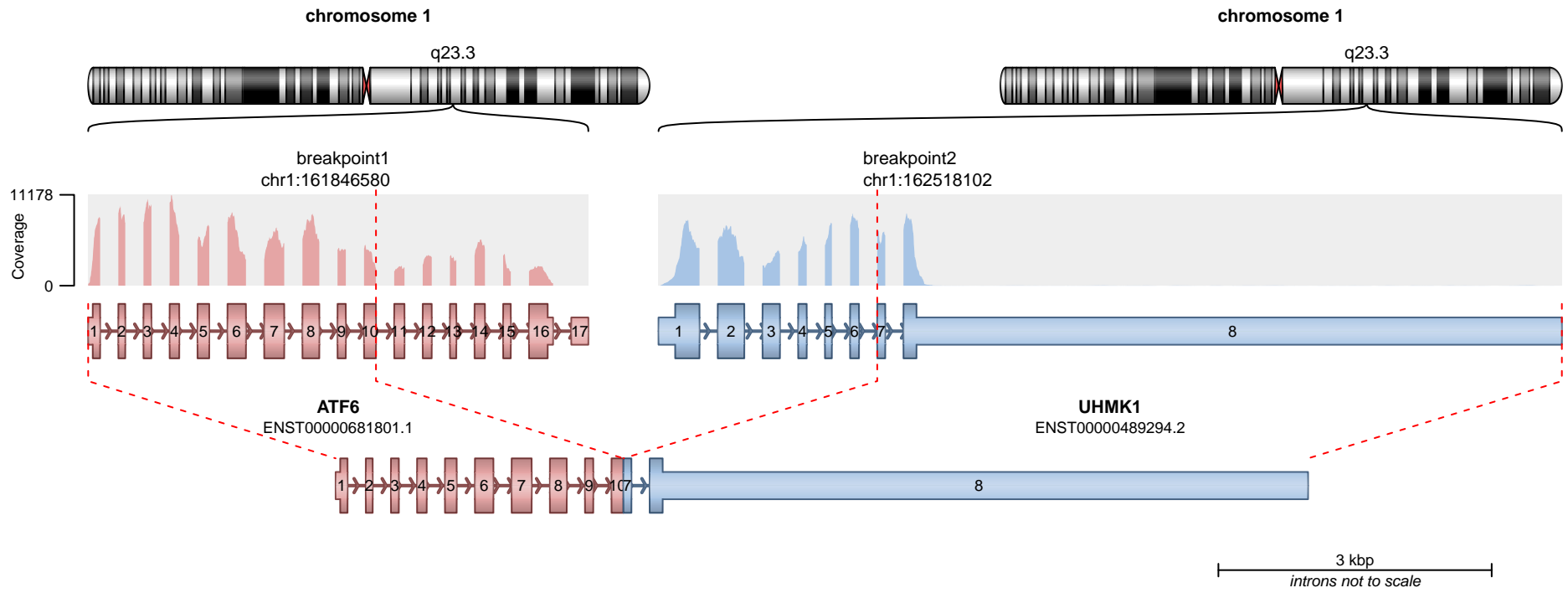

**RETAINED PROTEIN DOMAINS**  
reading frame unclear

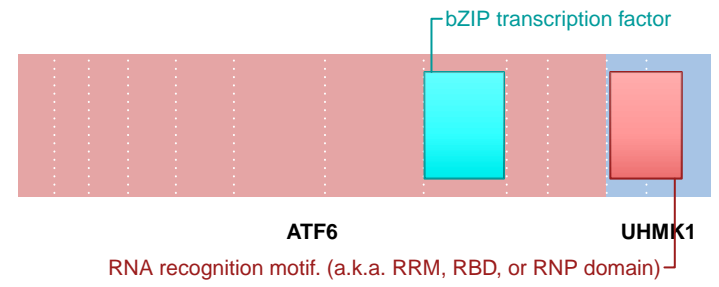

**SUPPORTING READ COUNT**

Split reads = 1  
Discordant mates = 0

- translocation
- duplication
- deletion
- inversion