

RETAINED PROTEIN DOMAINS
reading frame unclear



SUPPORTING READ COUNT

Split reads = 3626
Discordant mates = 140

- translocation
- duplication
- deletion
- inversion

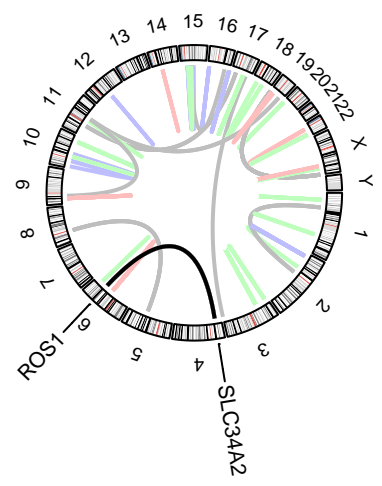
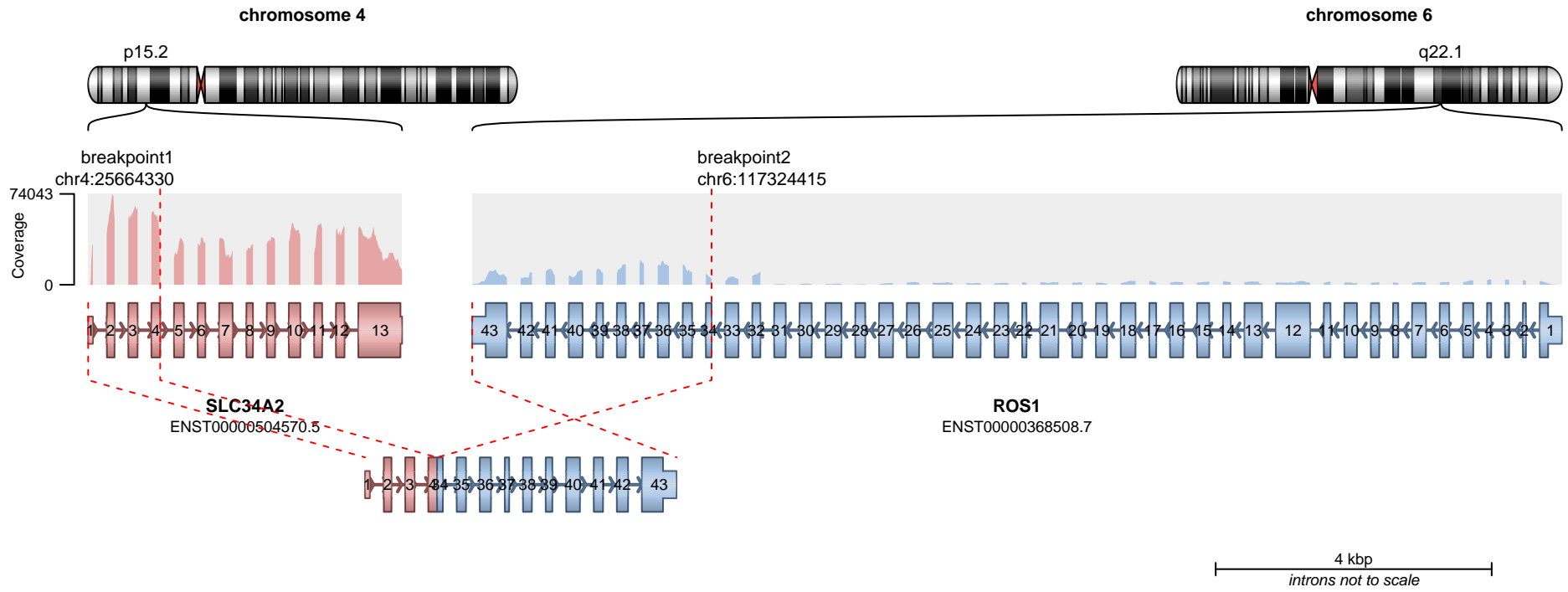

— translocation — deletion
— duplication — inversion

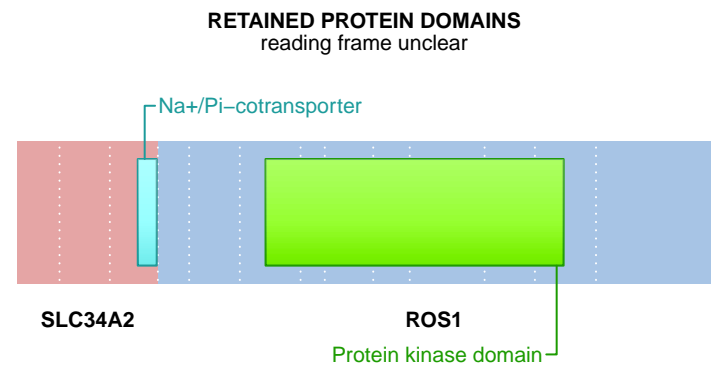

SUPPORTING READ COUNT

Split reads = 445
Discordant mates = 49

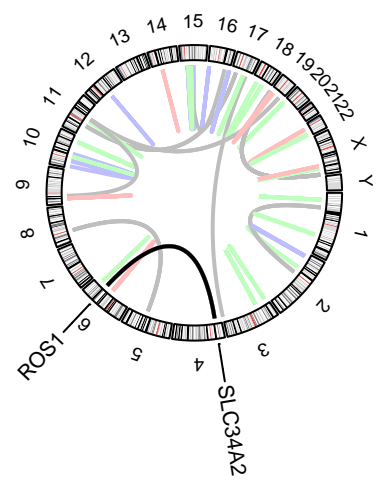
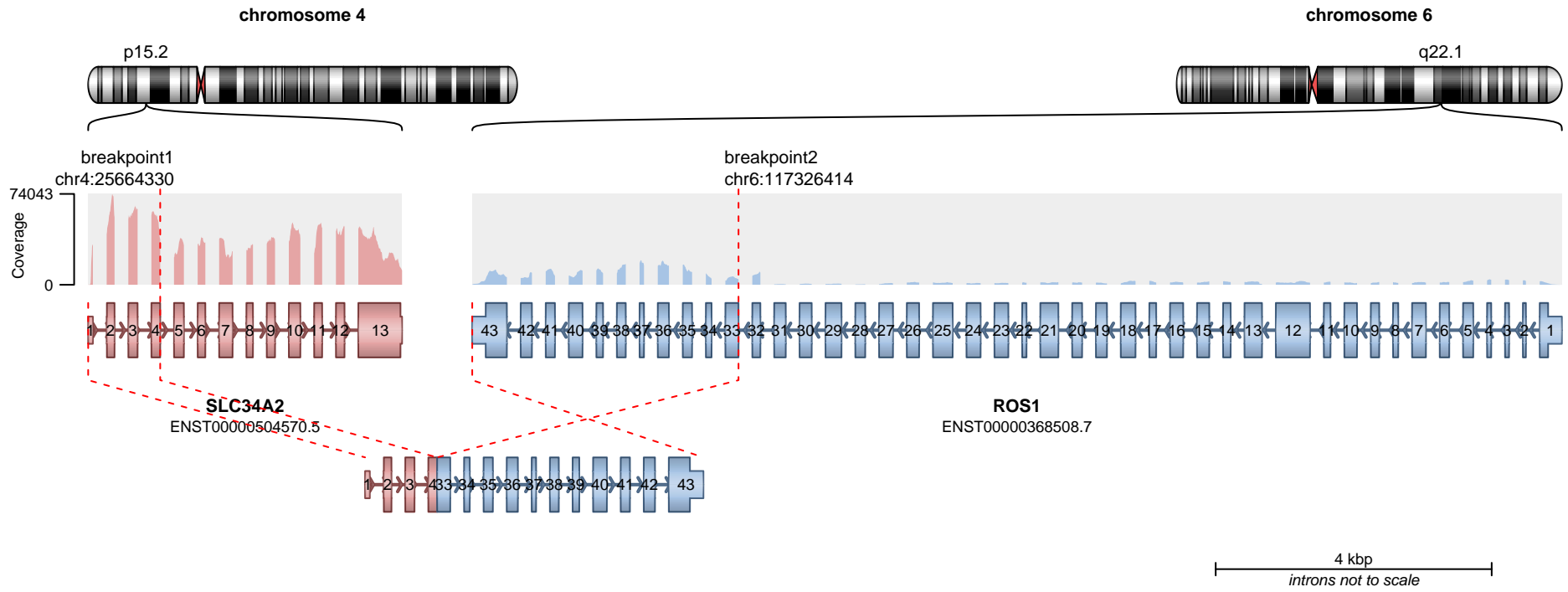

— translocation — deletion
— duplication — inversion

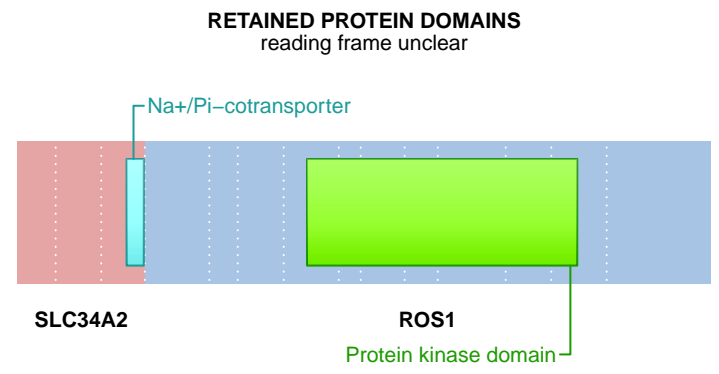

SUPPORTING READ COUNT

Split reads = 83
Discordant mates = 53

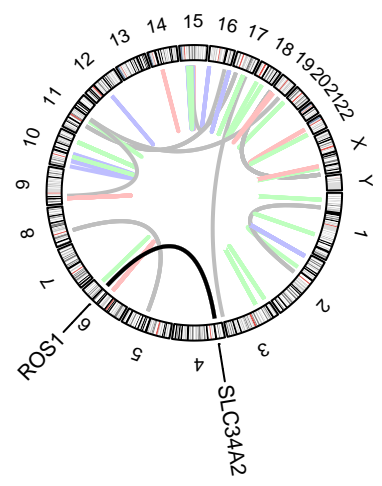
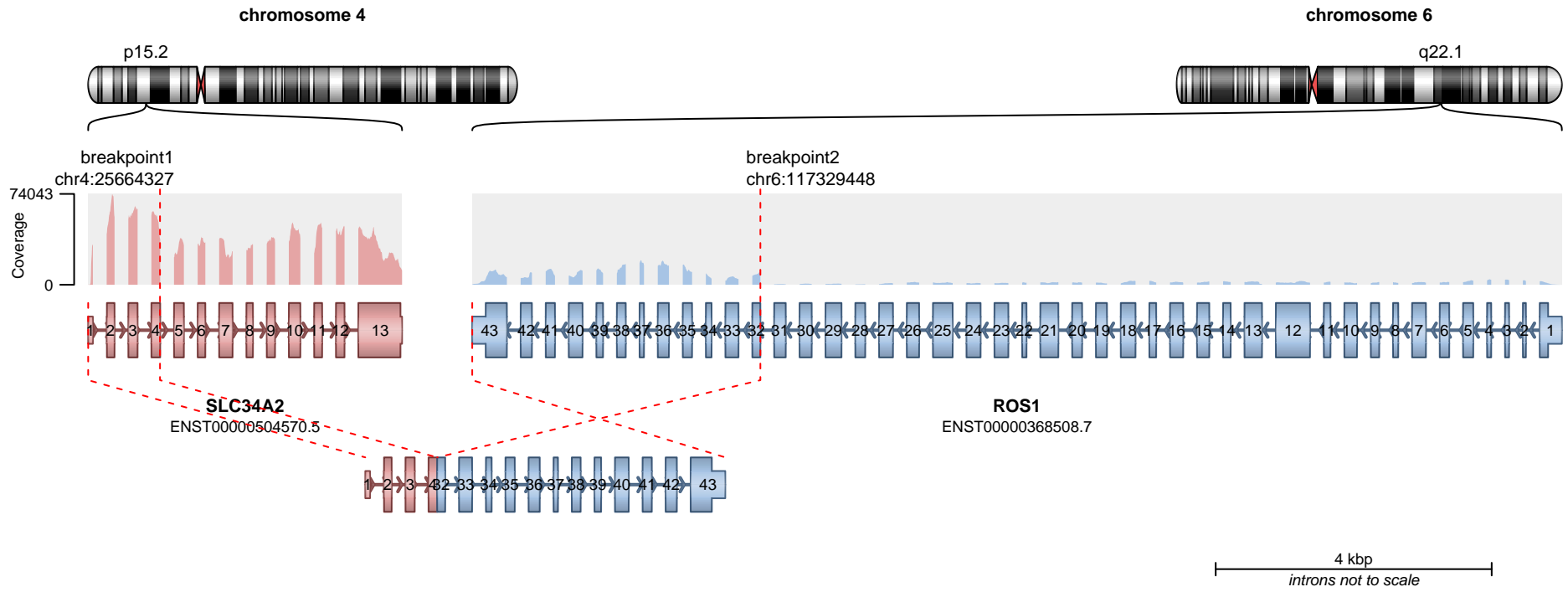

RETAINED PROTEIN DOMAINS
reading frame unclear

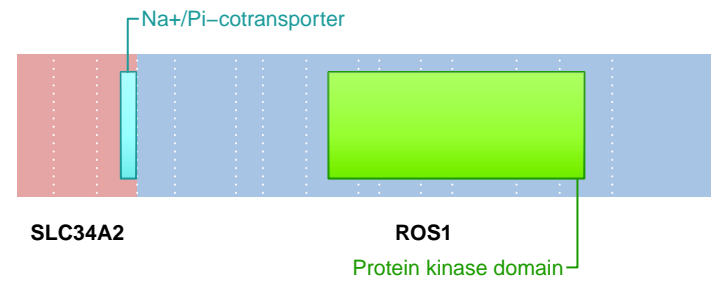

SUPPORTING READ COUNT

Split reads = 5
Discordant mates = 140

- translocation
- duplication
- deletion
- inversion

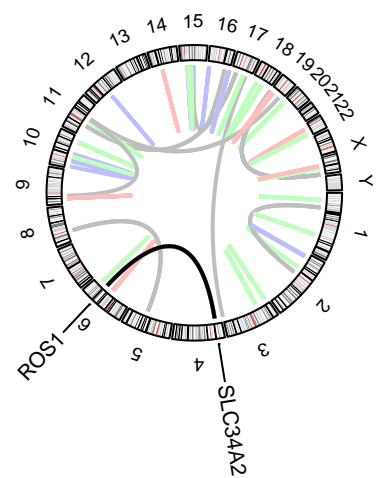
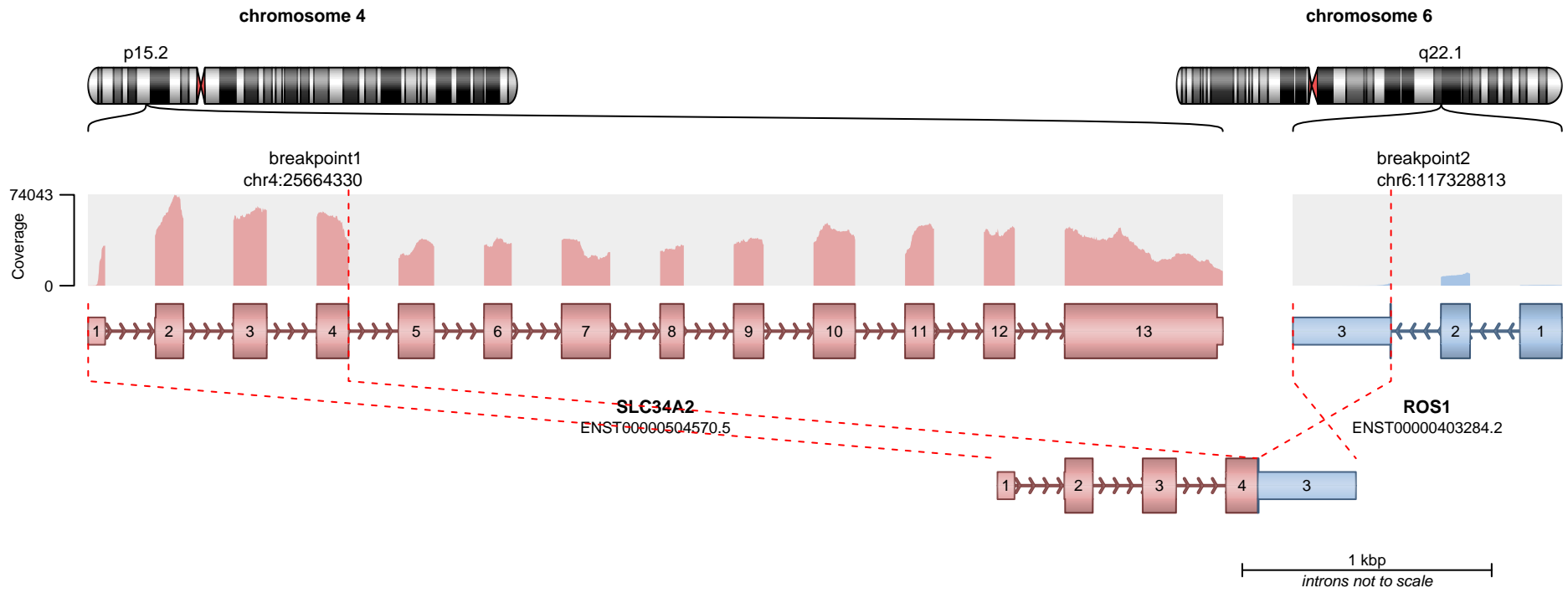

RETAINED PROTEIN DOMAINS
reading frame unclear

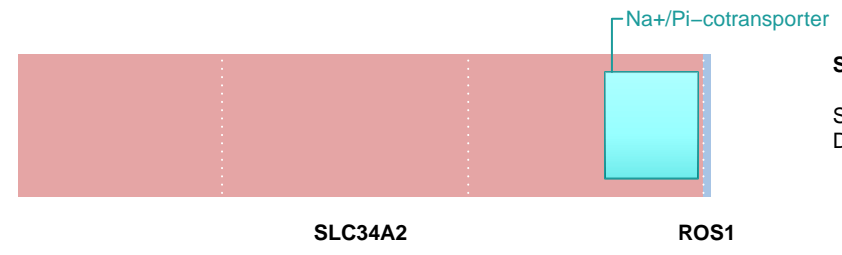

SUPPORTING READ COUNT

Split reads = 1
Discordant mates = 54

- translocation
- duplication
- deletion
- inversion

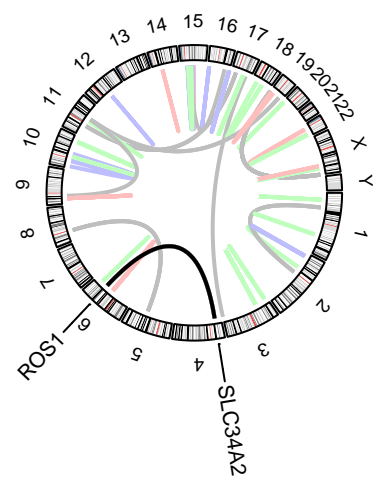
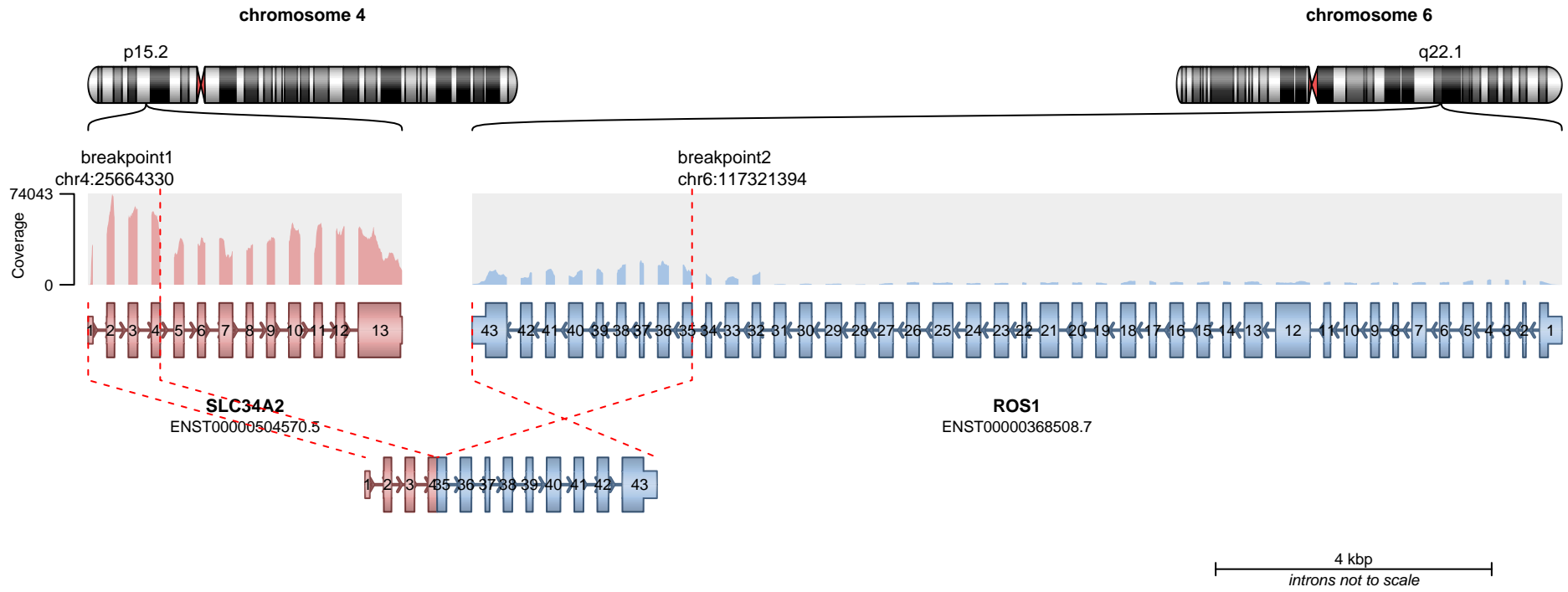

— translocation — deletion
— duplication — inversion

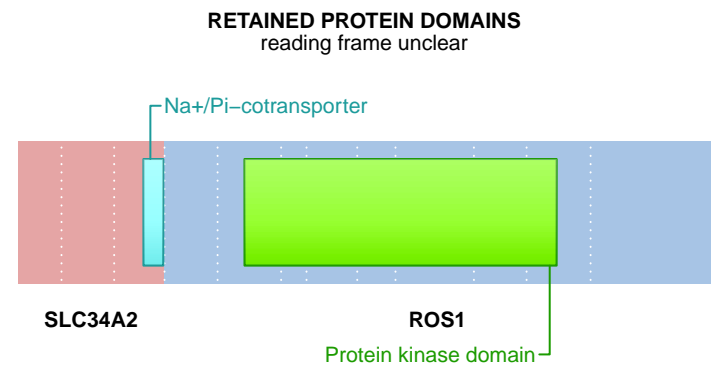

SUPPORTING READ COUNT

Split reads = 12
Discordant mates = 8

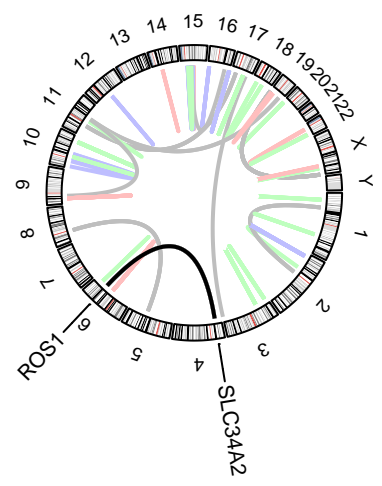
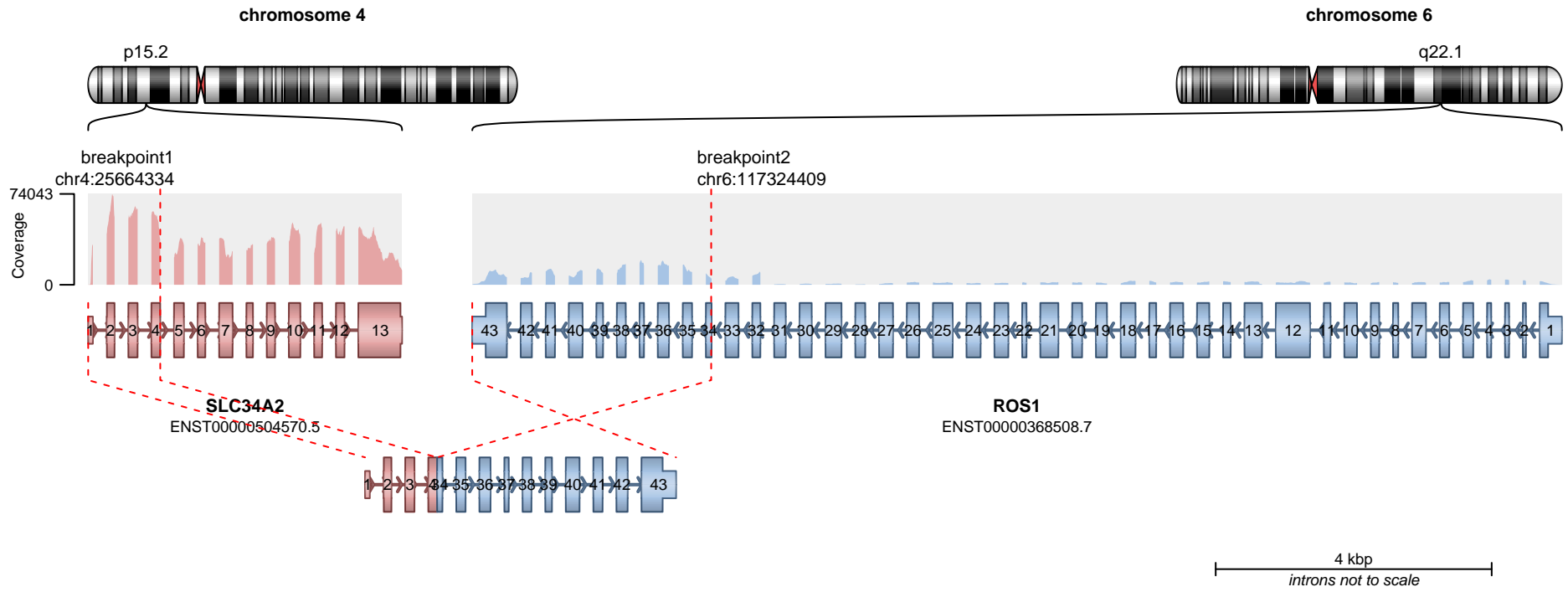

— translocation — deletion
— duplication — inversion

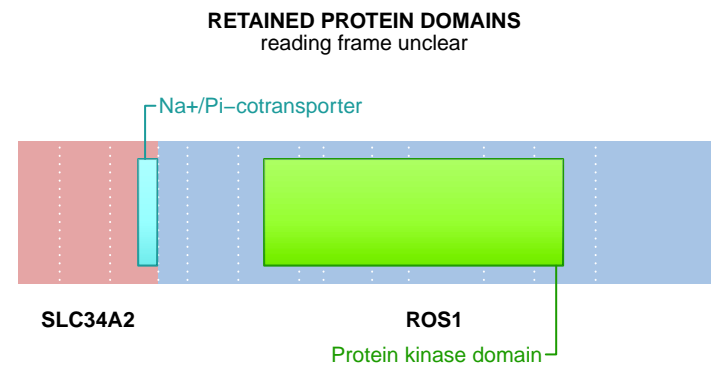

SUPPORTING READ COUNT

Split reads = 4
Discordant mates = 27

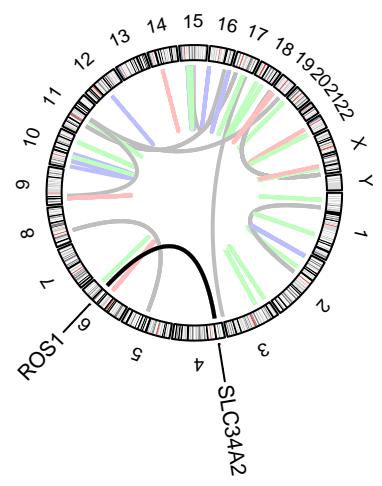
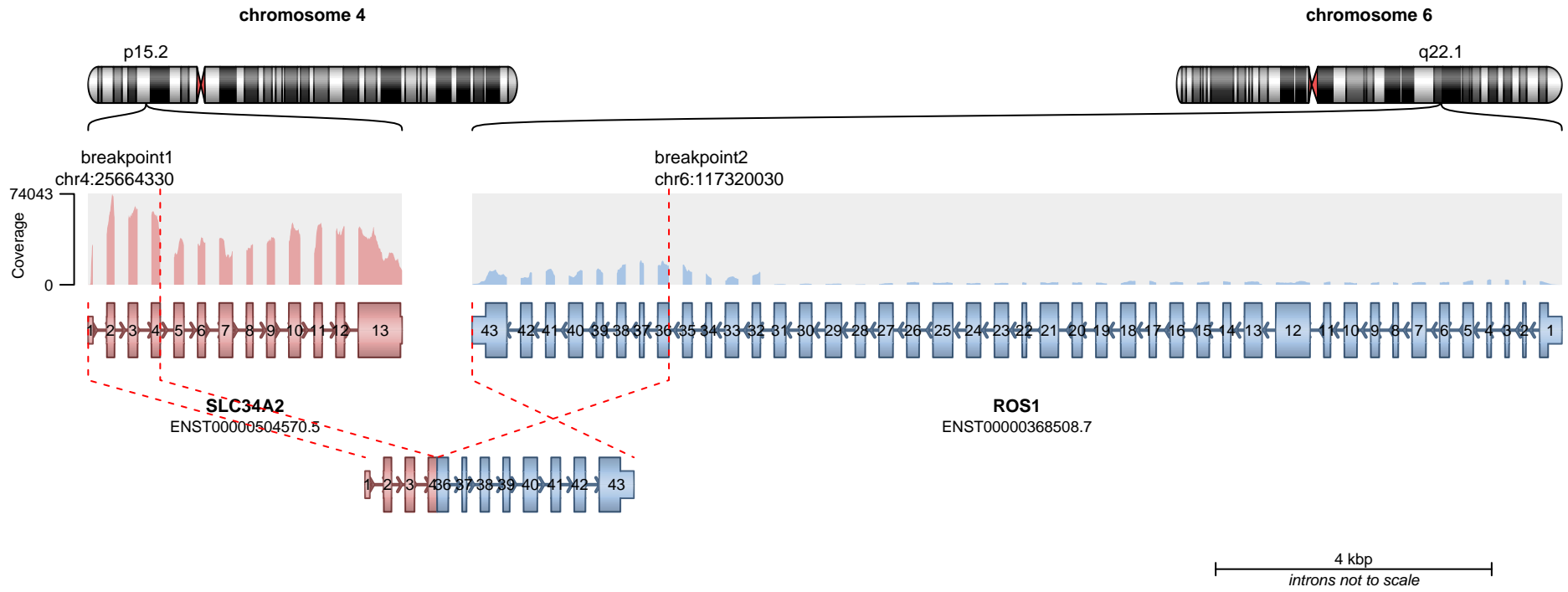

— translocation — deletion
— duplication — inversion

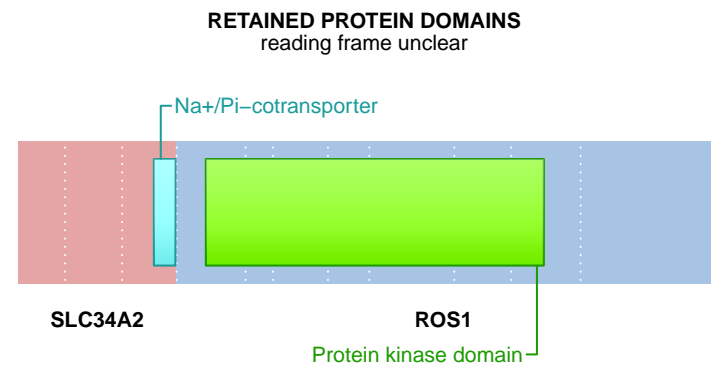

SUPPORTING READ COUNT

Split reads = 5
Discordant mates = 0

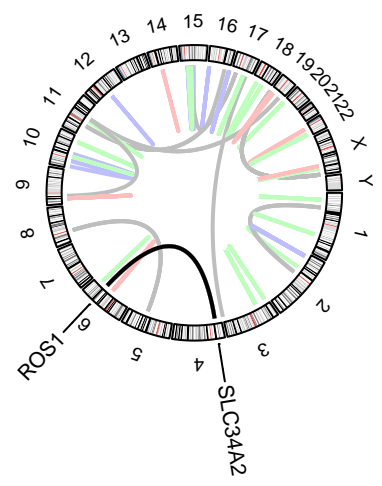
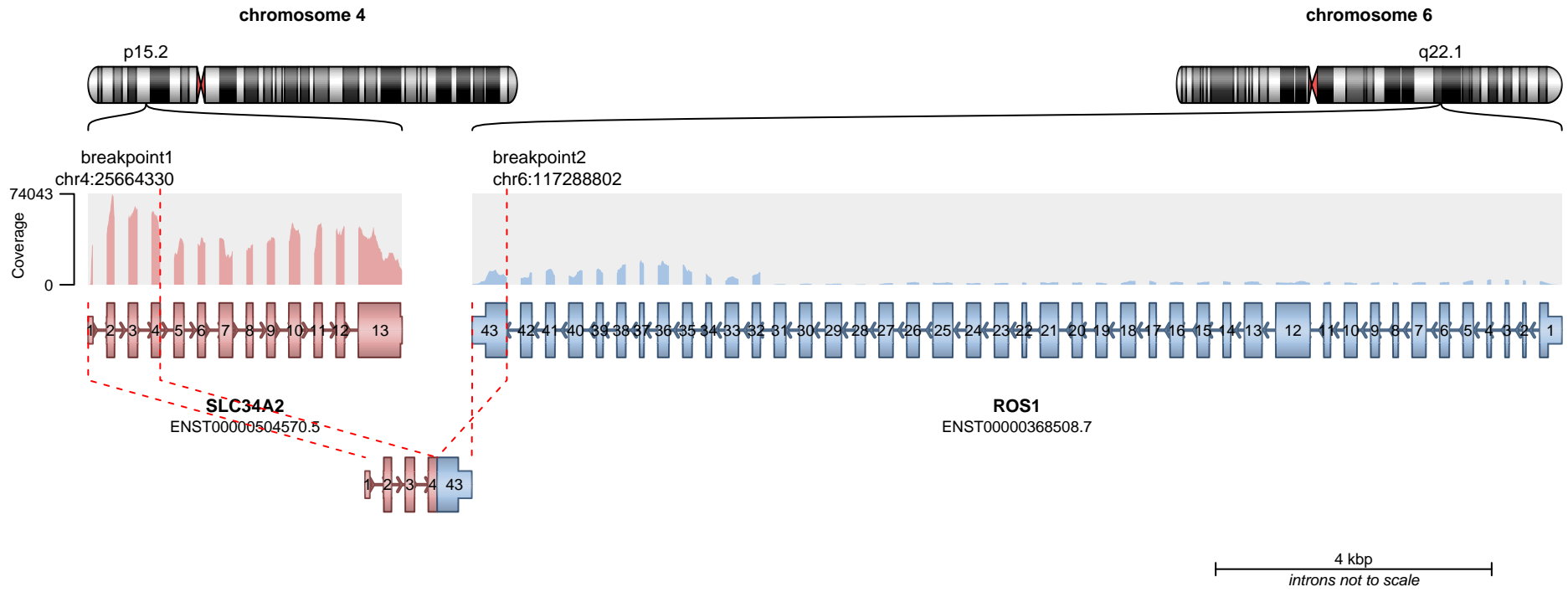

RETAINED PROTEIN DOMAINS
reading frame unclear

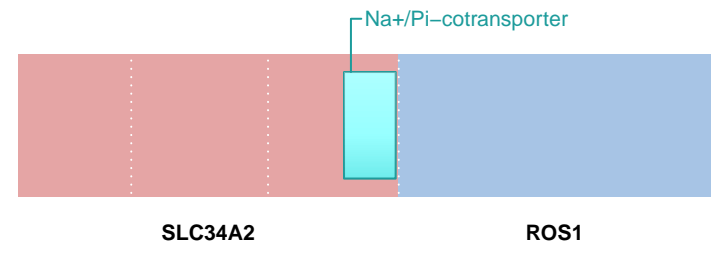

SUPPORTING READ COUNT

Split reads = 3
Discordant mates = 0

— translocation — deletion
— duplication — inversion

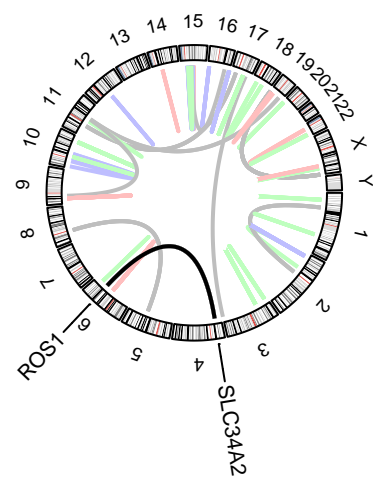
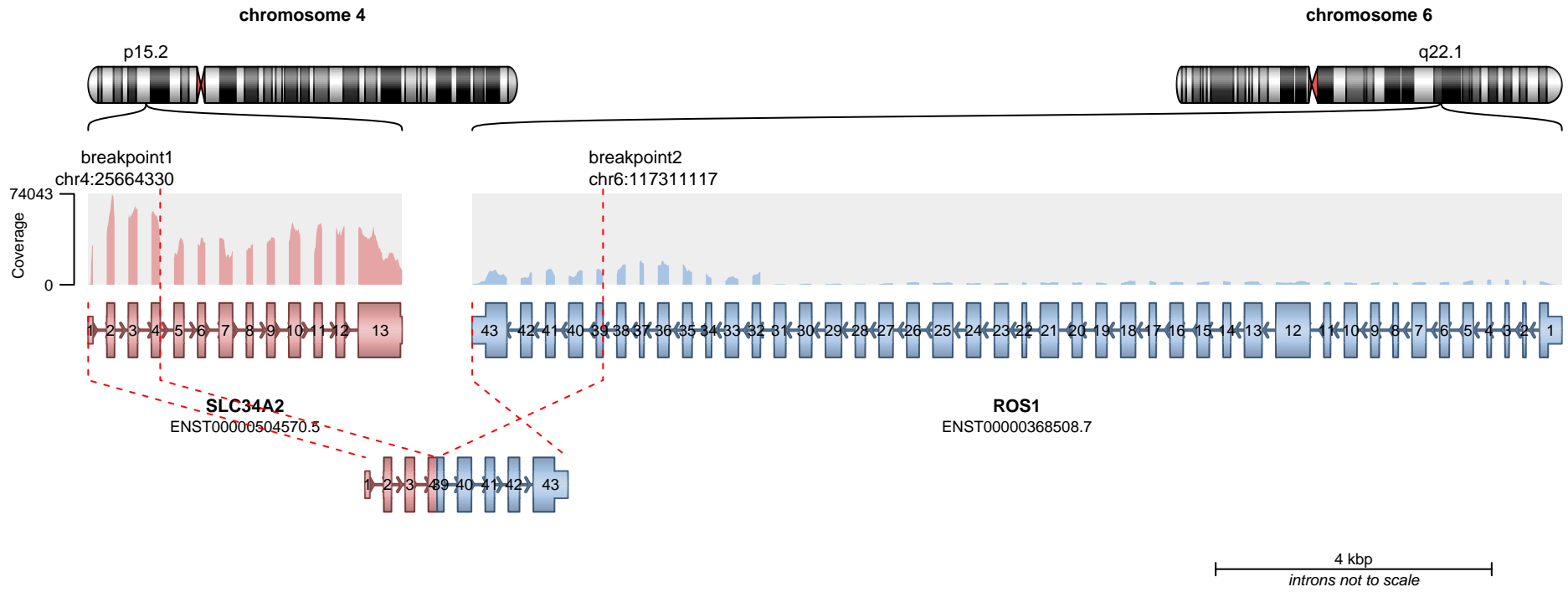

— translocation — deletion
— duplication — inversion

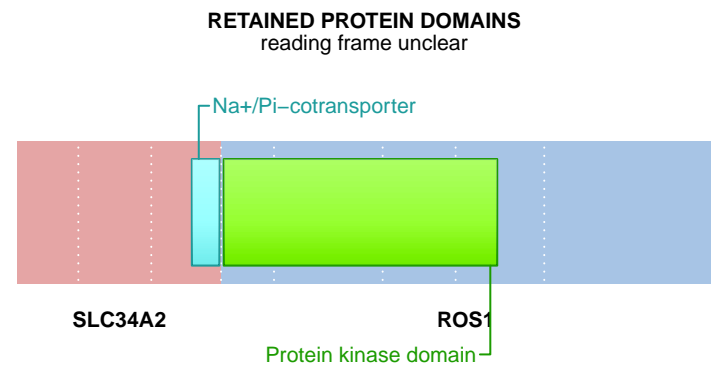

SUPPORTING READ COUNT

Split reads = 1
Discordant mates = 0

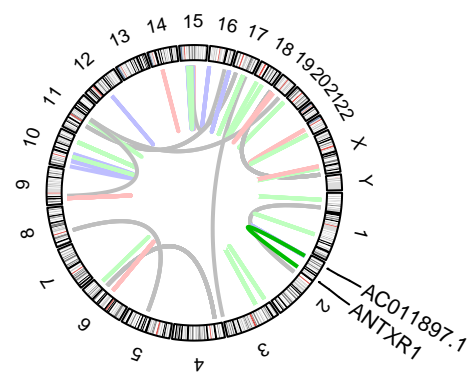
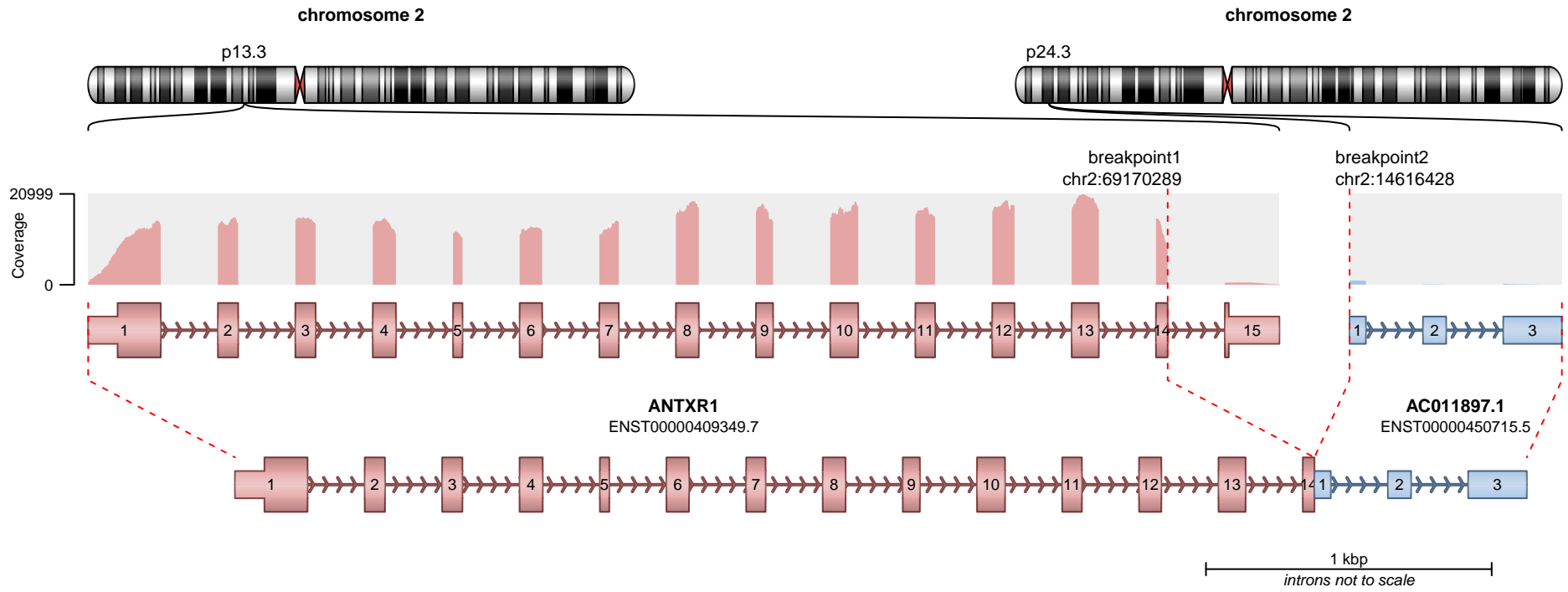

RETAINED PROTEIN DOMAINS
reading frame unclear

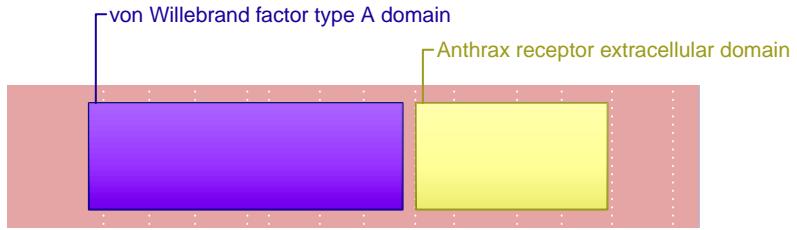

ANTXR1

SUPPORTING READ COUNT

Split reads = 763
Discordant mates = 32

- translocation
- duplication
- deletion
- inversion

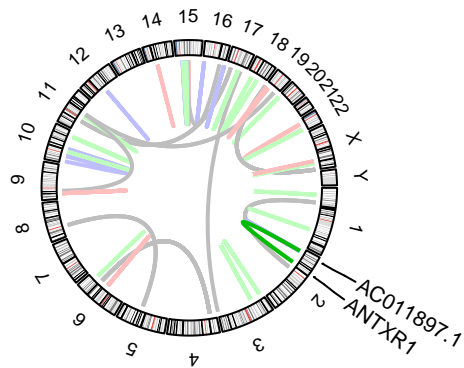
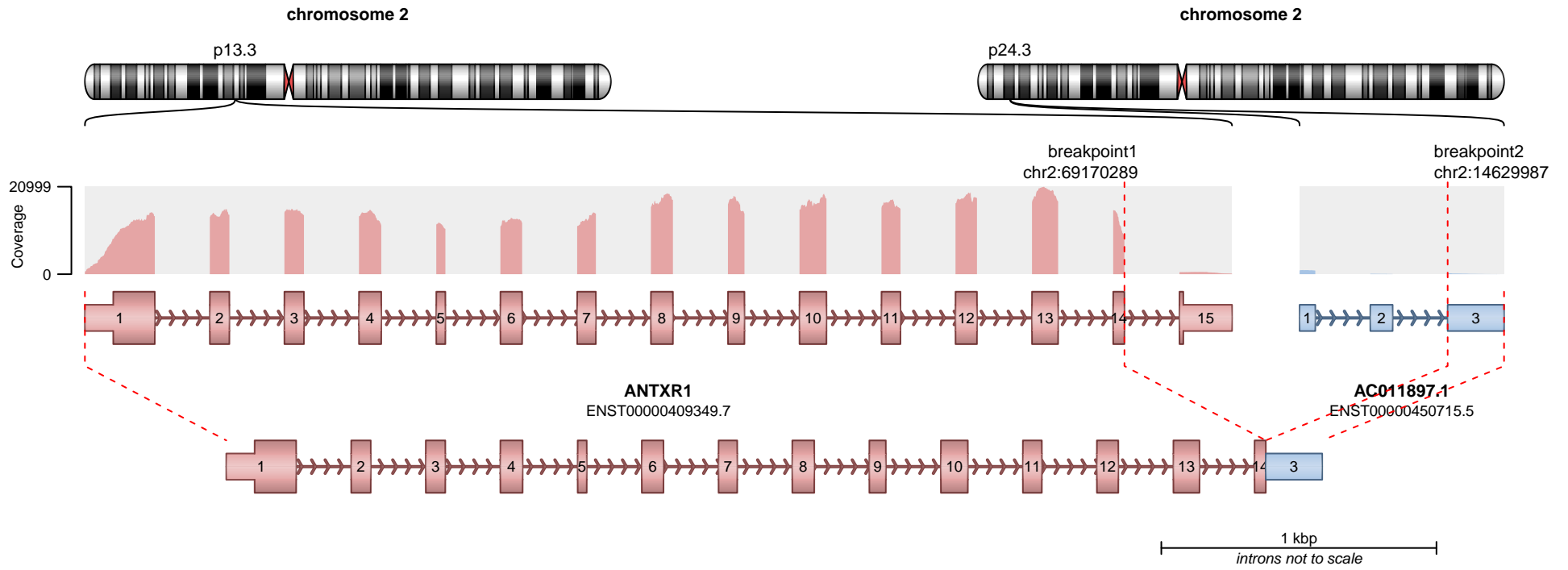

RETAINED PROTEIN DOMAINS
reading frame unclear

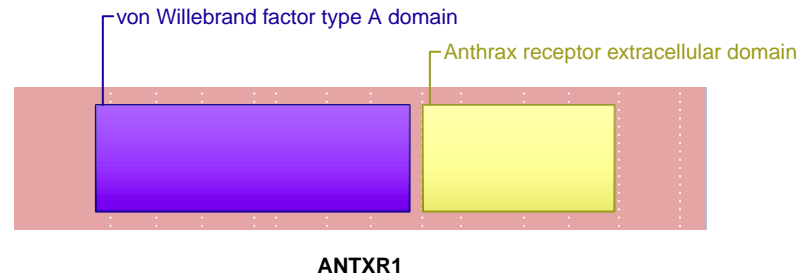

SUPPORTING READ COUNT

Split reads = 3
Discordant mates = 11

— translocation — deletion
— duplication — inversion

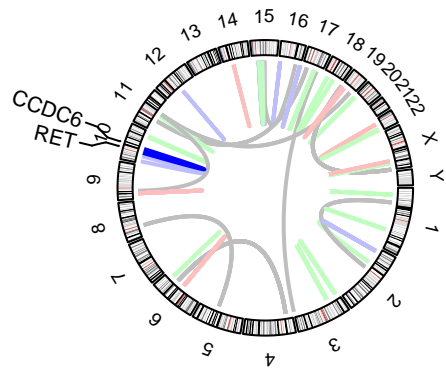
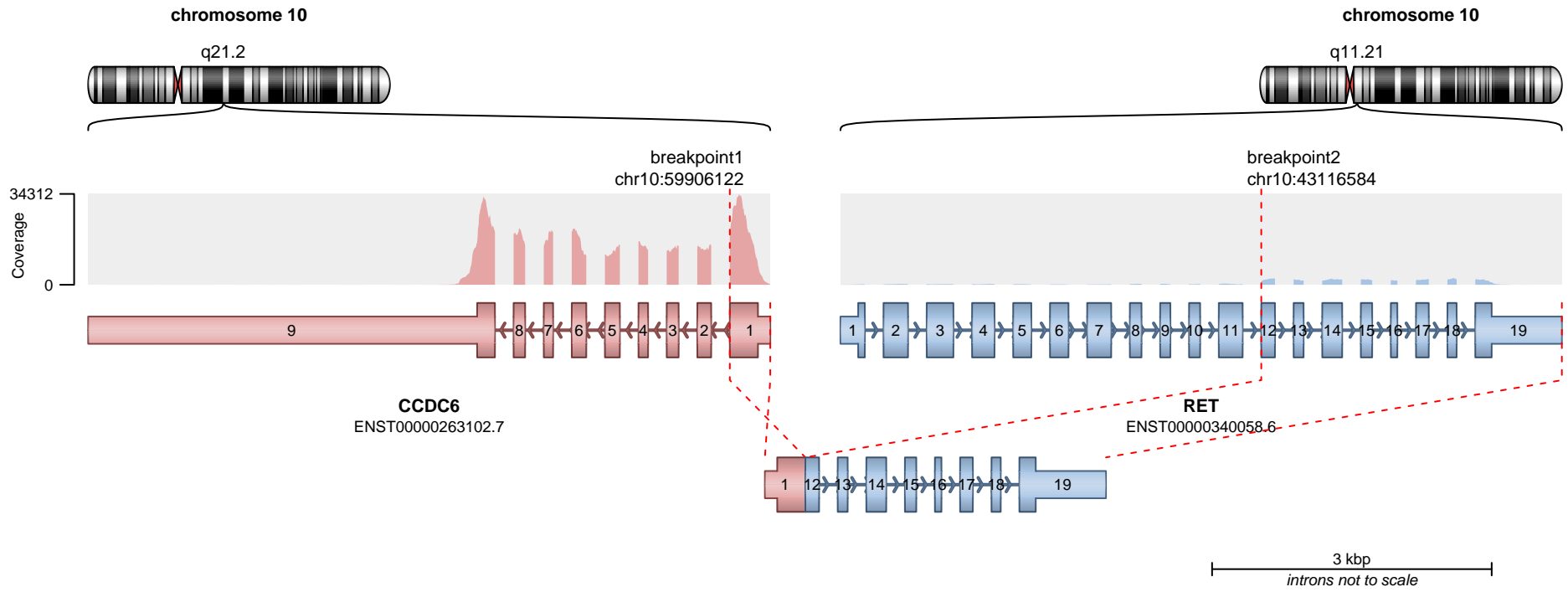

RETAINED PROTEIN DOMAINS
reading frame unclear

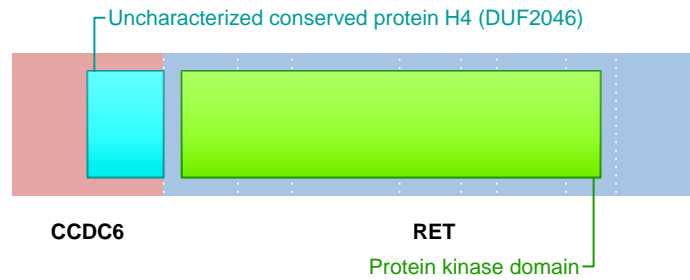

SUPPORTING READ COUNT

Split reads = 496
Discordant mates = 29

— translocation — deletion
— duplication — inversion

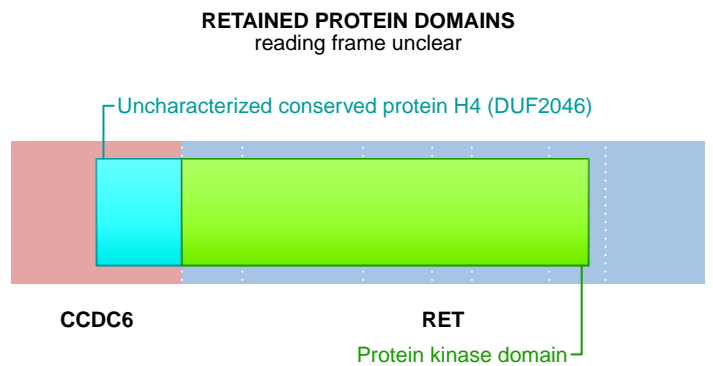
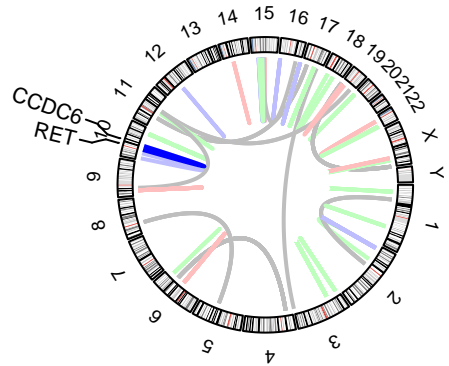
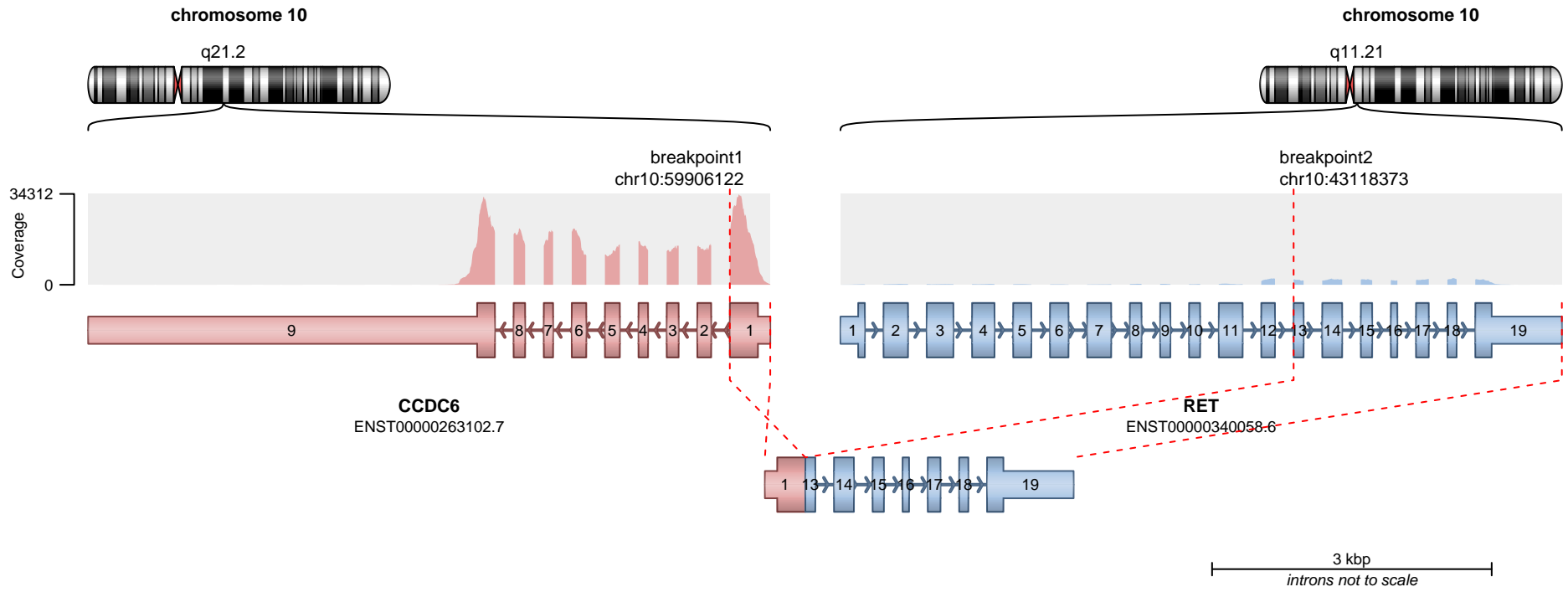

SUPPORTING READ COUNT

Split reads = 1
Discordant mates = 0

— translocation — deletion
— duplication — inversion

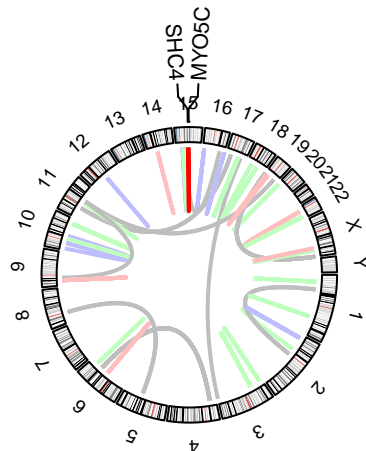
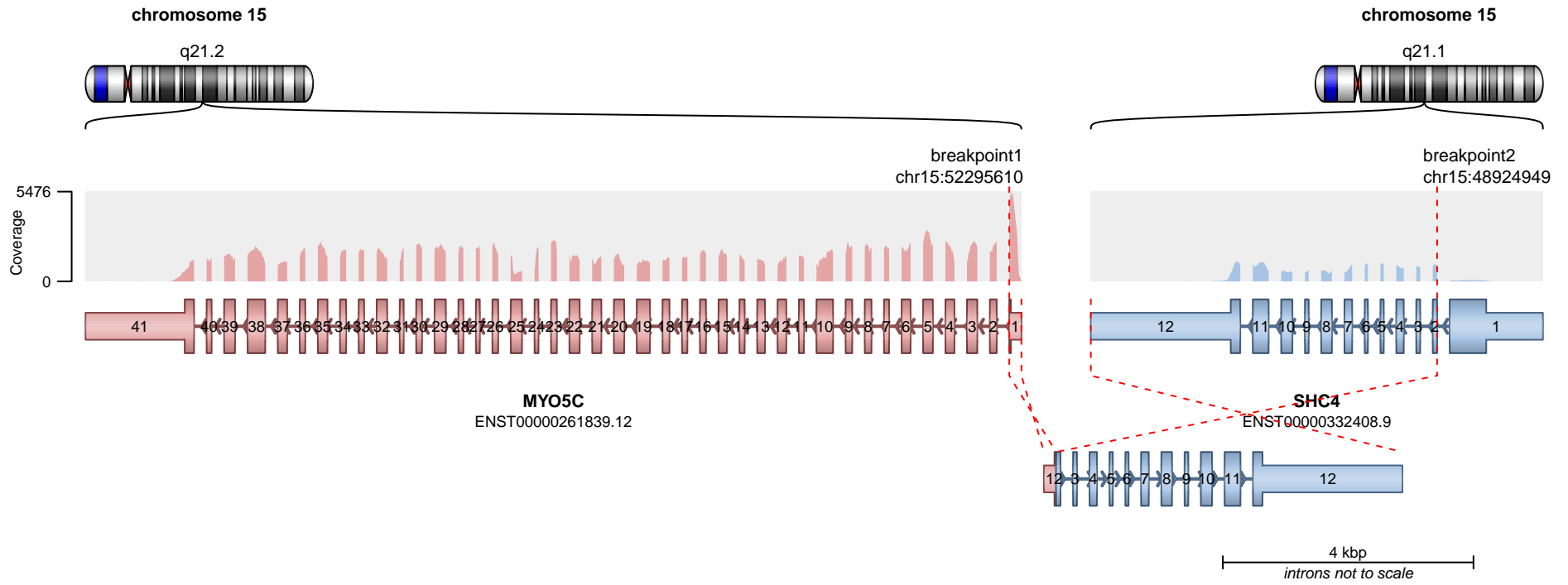

RETAINED PROTEIN DOMAINS
reading frame unclear

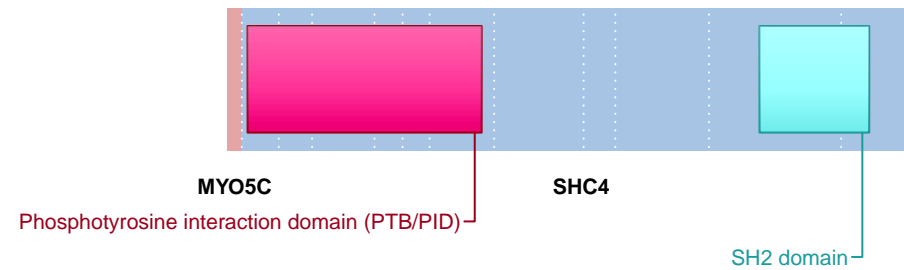

SUPPORTING READ COUNT

Split reads = 488
Discordant mates = 21

- translocation
- duplication
- deletion
- inversion

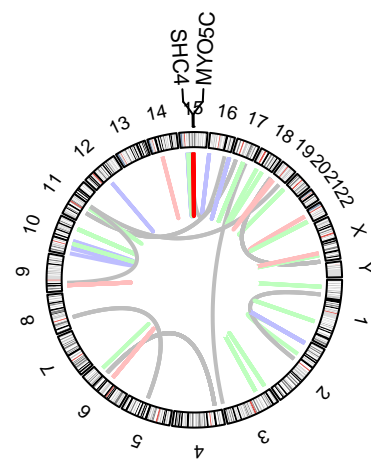
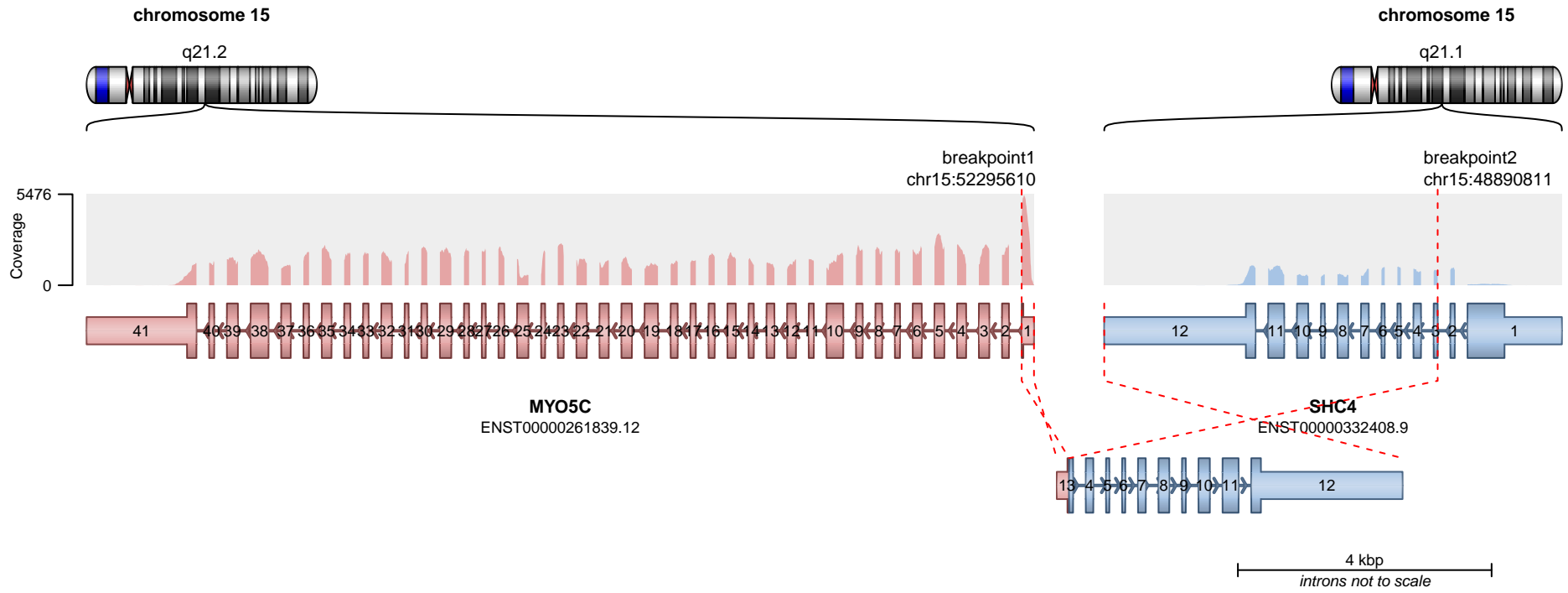

RETAINED PROTEIN DOMAINS
reading frame unclear

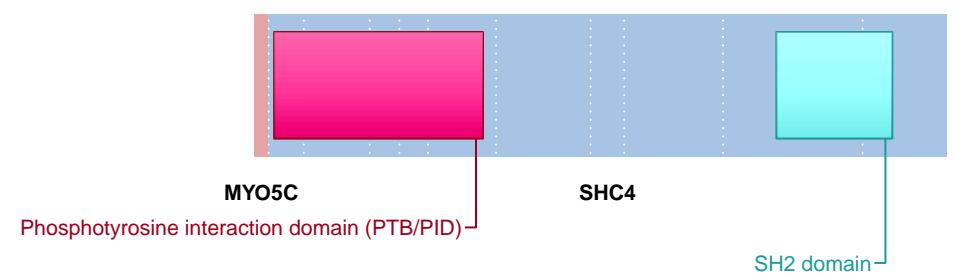

SUPPORTING READ COUNT

Split reads = 13
Discordant mates = 8

- translocation
- duplication
- deletion
- inversion

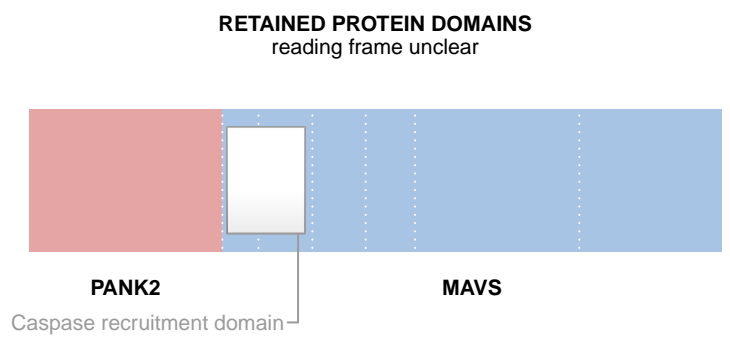
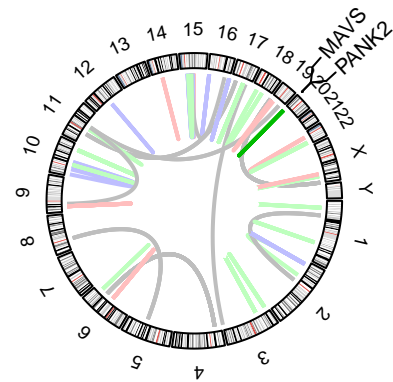
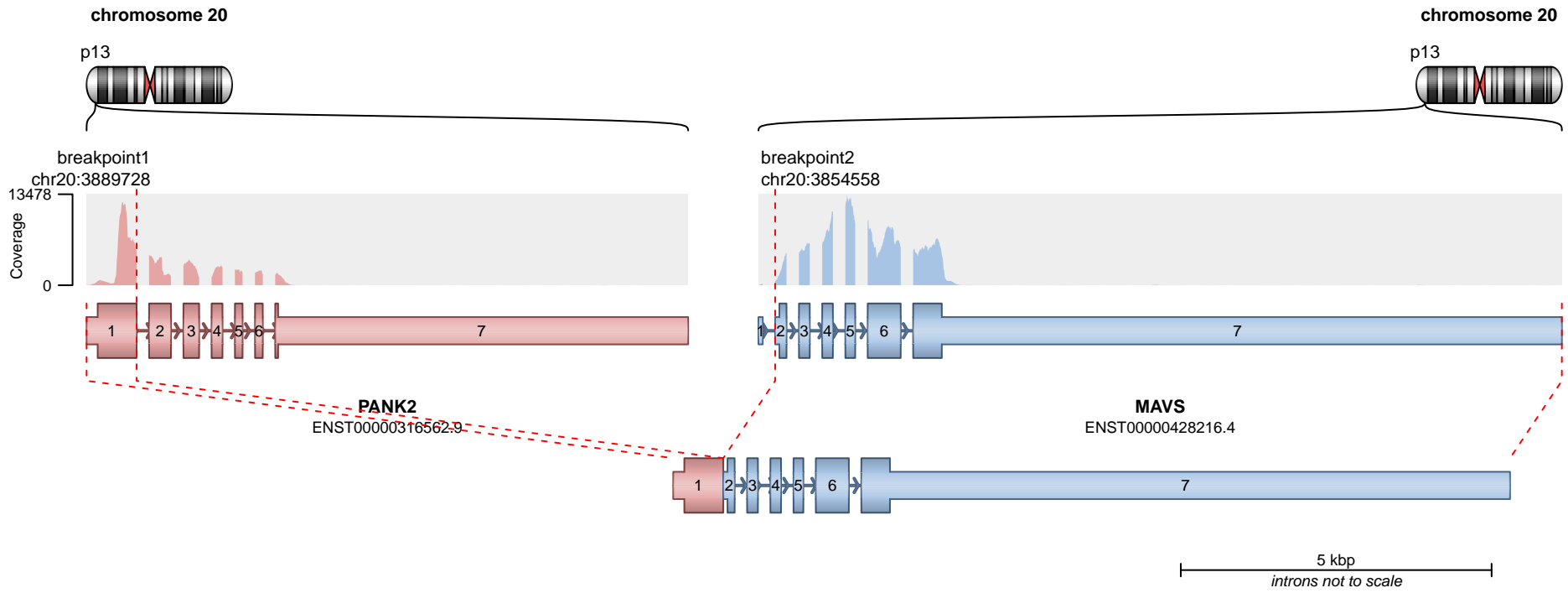

SUPPORTING READ COUNT

Split reads = 199
Discordant mates = 6

— translocation — deletion
— duplication — inversion

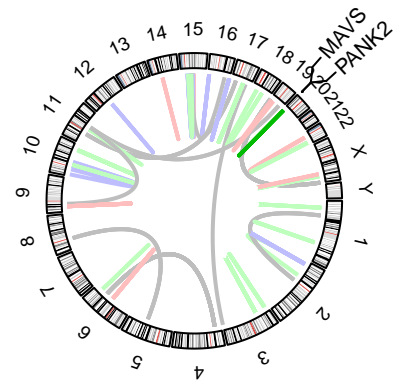
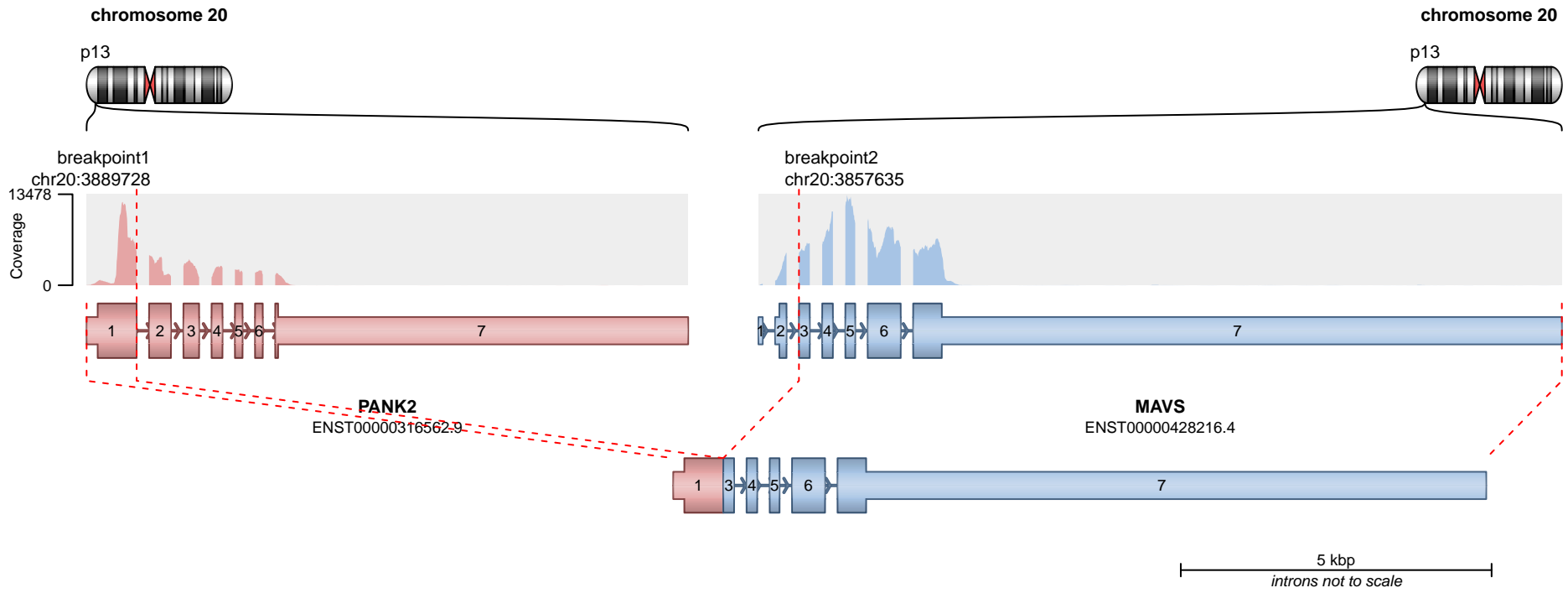

RETAINED PROTEIN DOMAINS
reading frame unclear

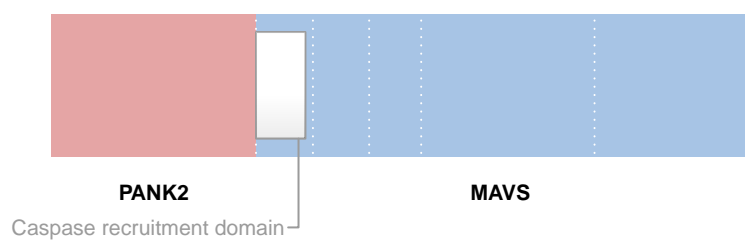

SUPPORTING READ COUNT

Split reads = 7
Discordant mates = 0

- translocation
- duplication
- deletion
- inversion

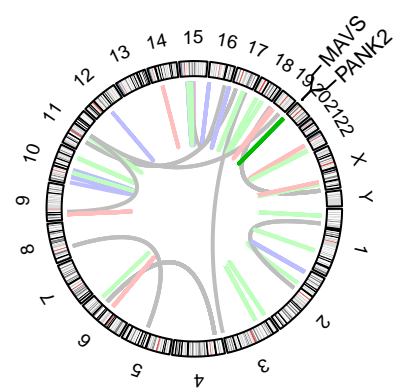
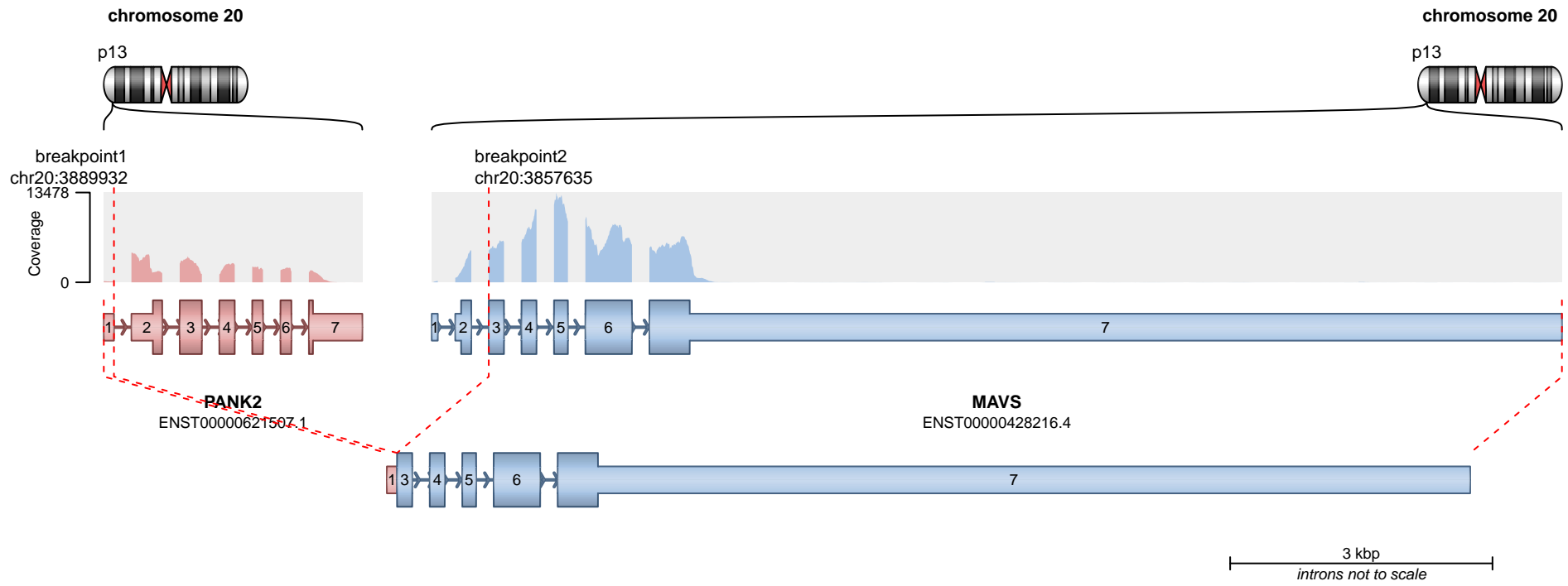

— translocation — deletion
— duplication — inversion

RETAINED PROTEIN DOMAINS
reading frame unclear

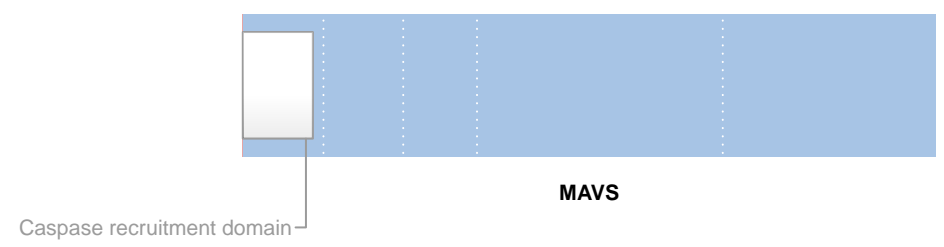

SUPPORTING READ COUNT

Split reads = 1
Discordant mates = 0

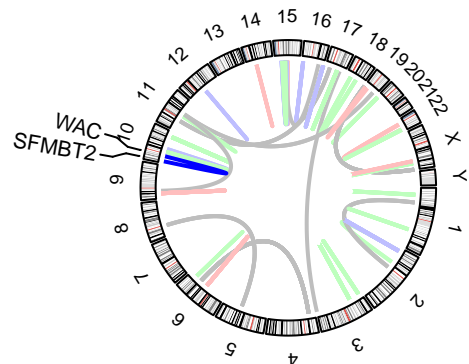
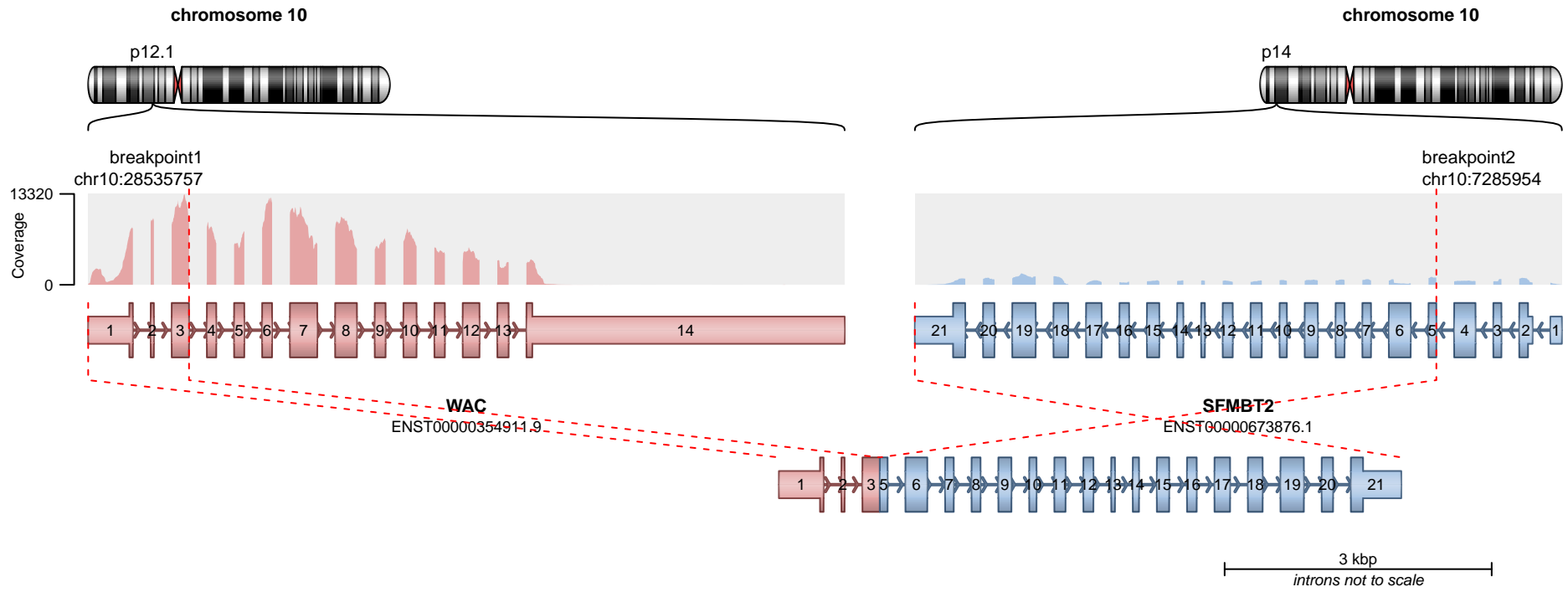

— translocation — deletion
— duplication — inversion

RETAINED PROTEIN DOMAINS
reading frame unclear

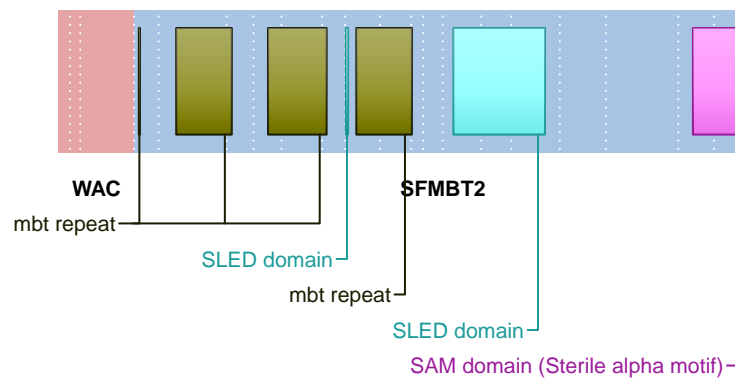

SUPPORTING READ COUNT

Split reads = 195
Discordant mates = 10

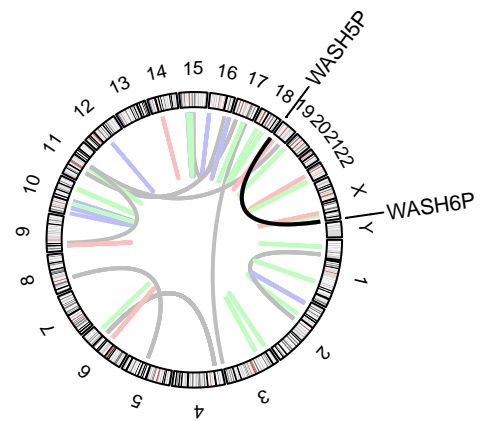
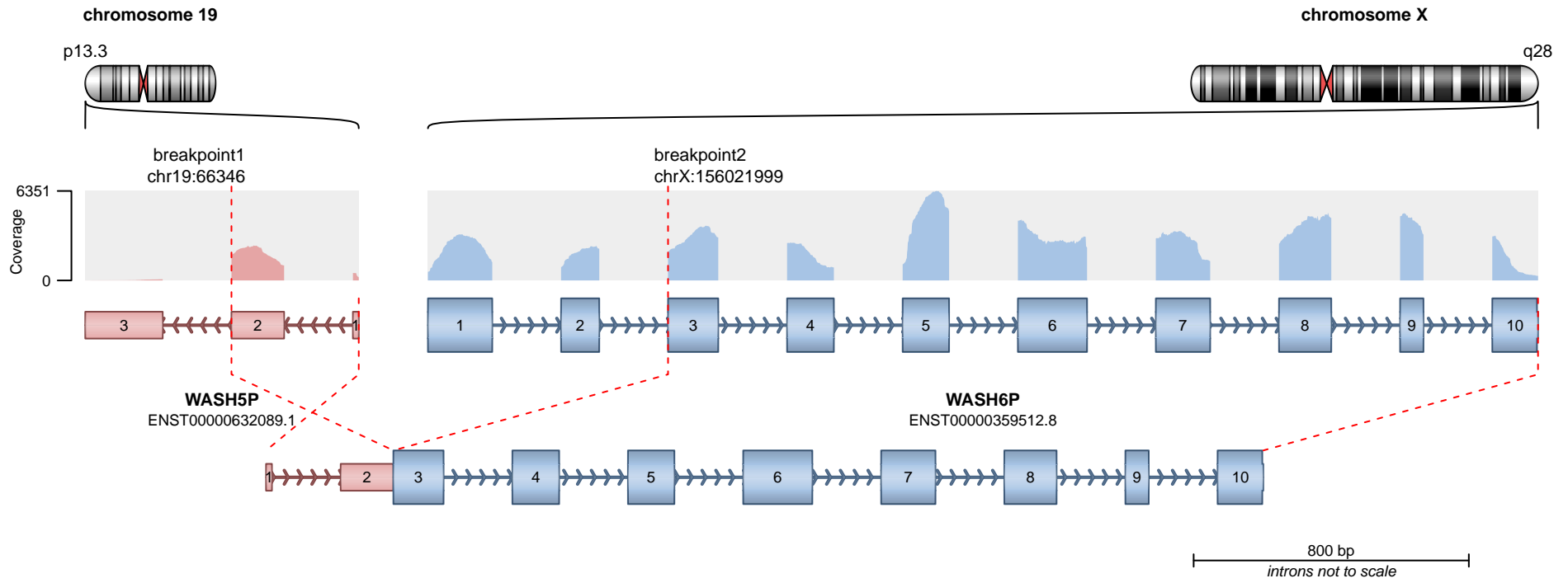

RETAINED PROTEIN DOMAINS
reading frame unclear

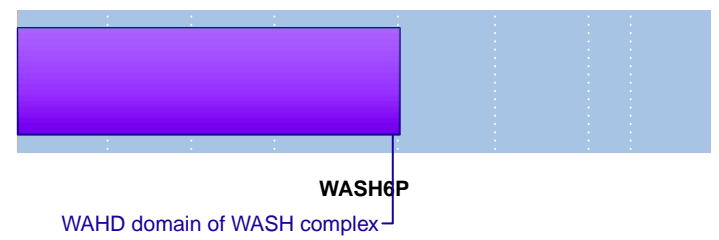

SUPPORTING READ COUNT

Split reads = 143
Discordant mates = 44

- translocation
- duplication
- deletion
- inversion

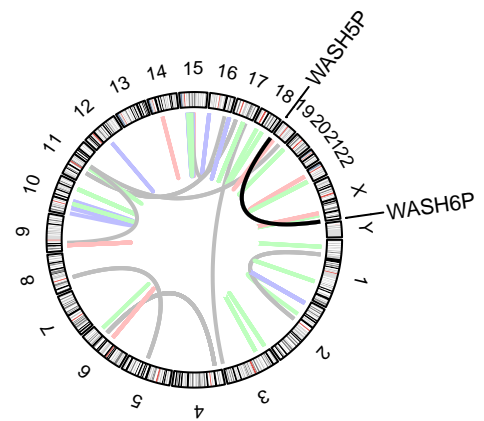
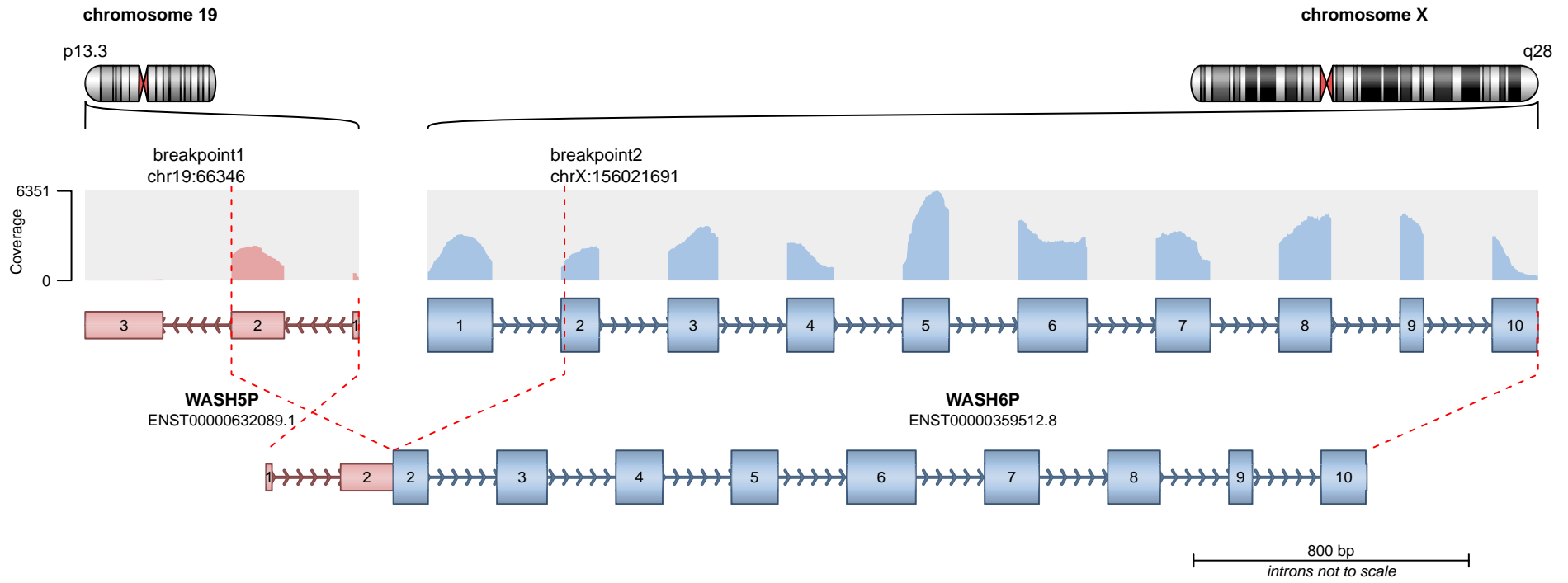

RETAINED PROTEIN DOMAINS
reading frame unclear

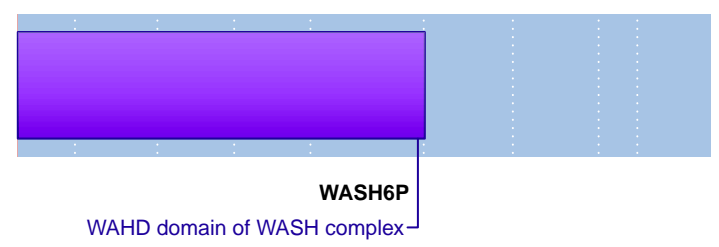

SUPPORTING READ COUNT

Split reads = 54
Discordant mates = 66

- translocation
- duplication
- deletion
- inversion

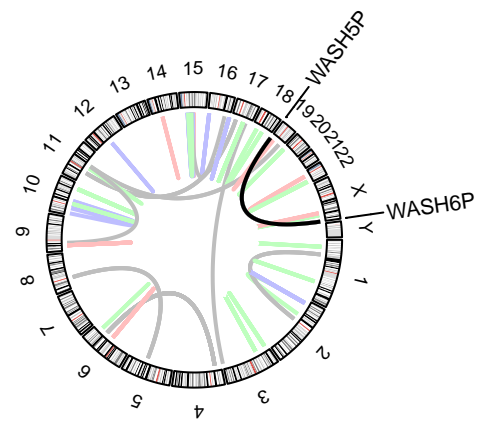
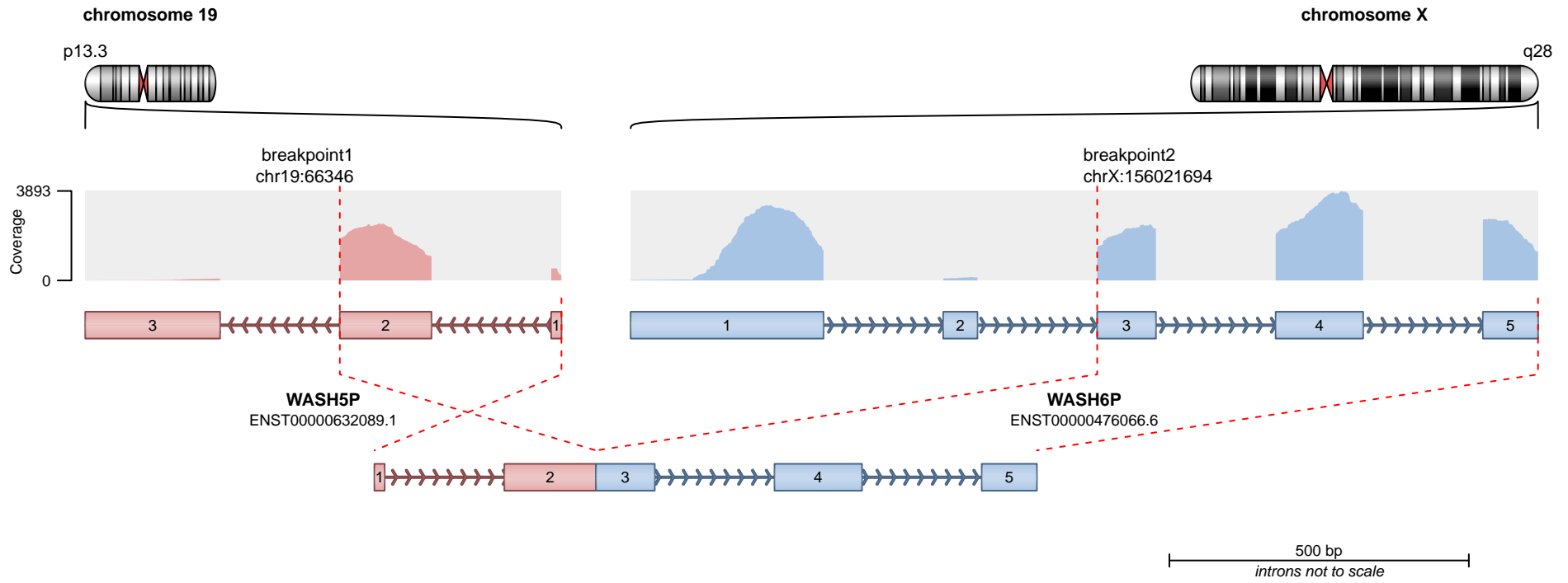

— translocation — deletion
— duplication — inversion

Genes are not protein-coding.

SUPPORTING READ COUNT

Split reads = 37
Discordant mates = 65

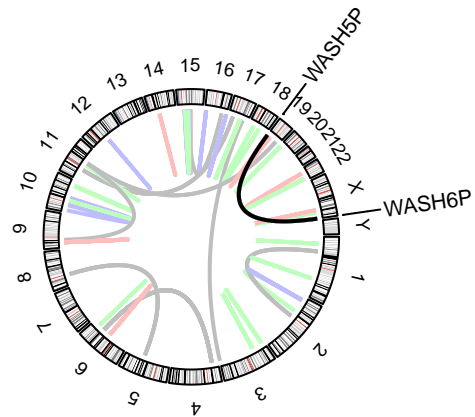
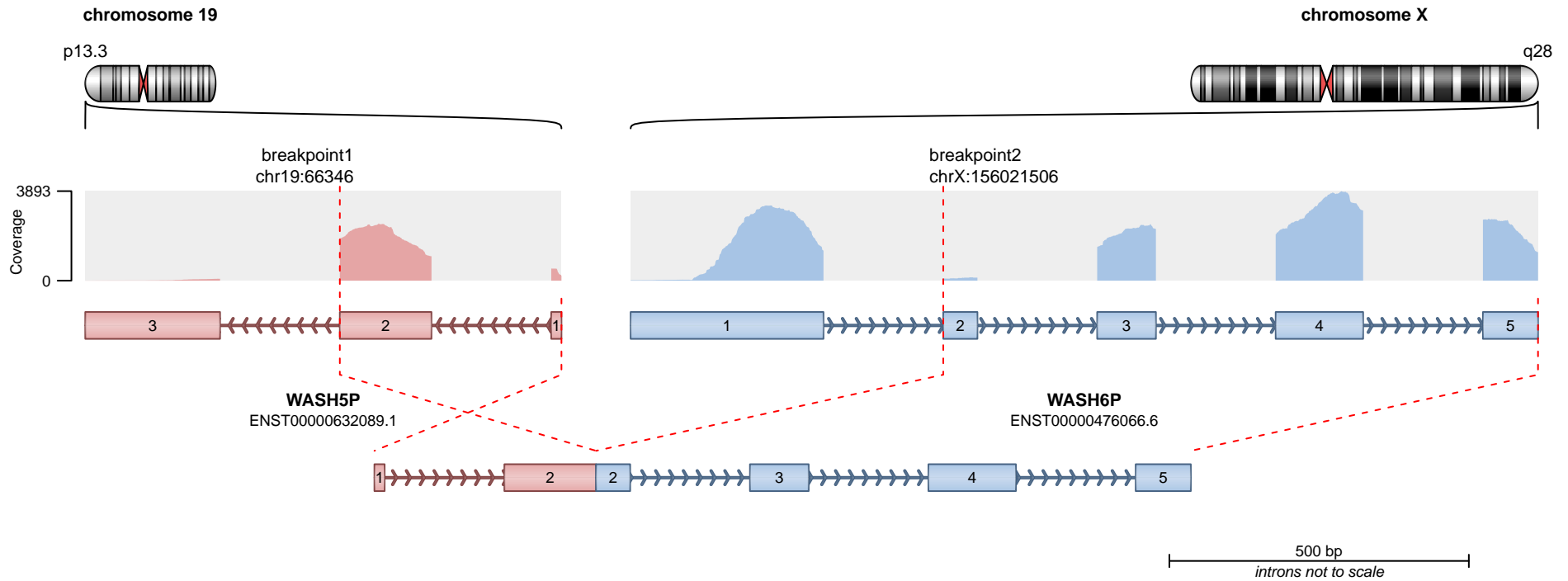

— translocation — deletion
— duplication — inversion

Genes are not protein-coding.

SUPPORTING READ COUNT

Split reads = 16
Discordant mates = 66

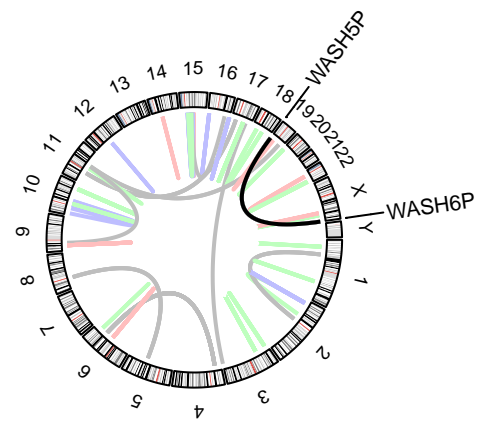
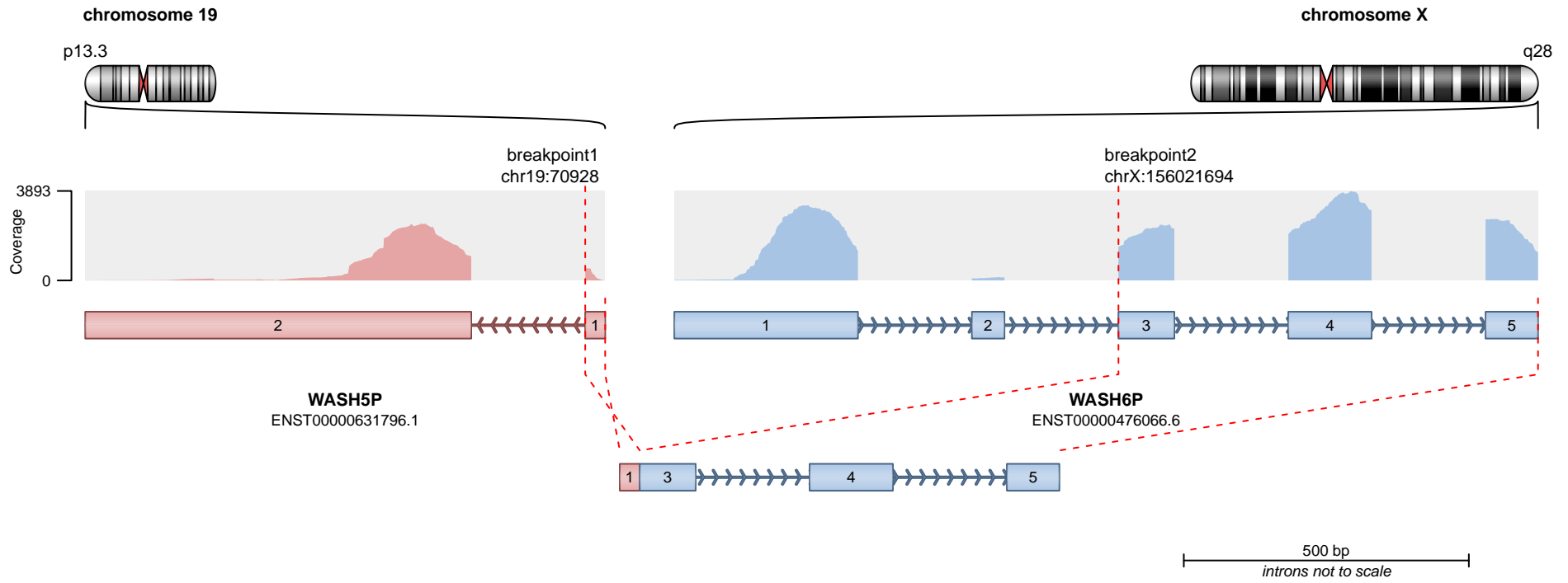

— translocation — deletion
— duplication — inversion

Genes are not protein-coding.

SUPPORTING READ COUNT

Split reads = 27
Discordant mates = 0

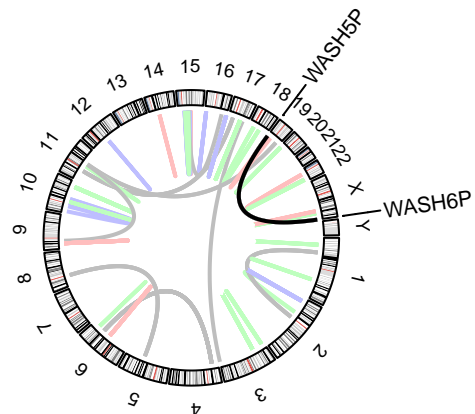
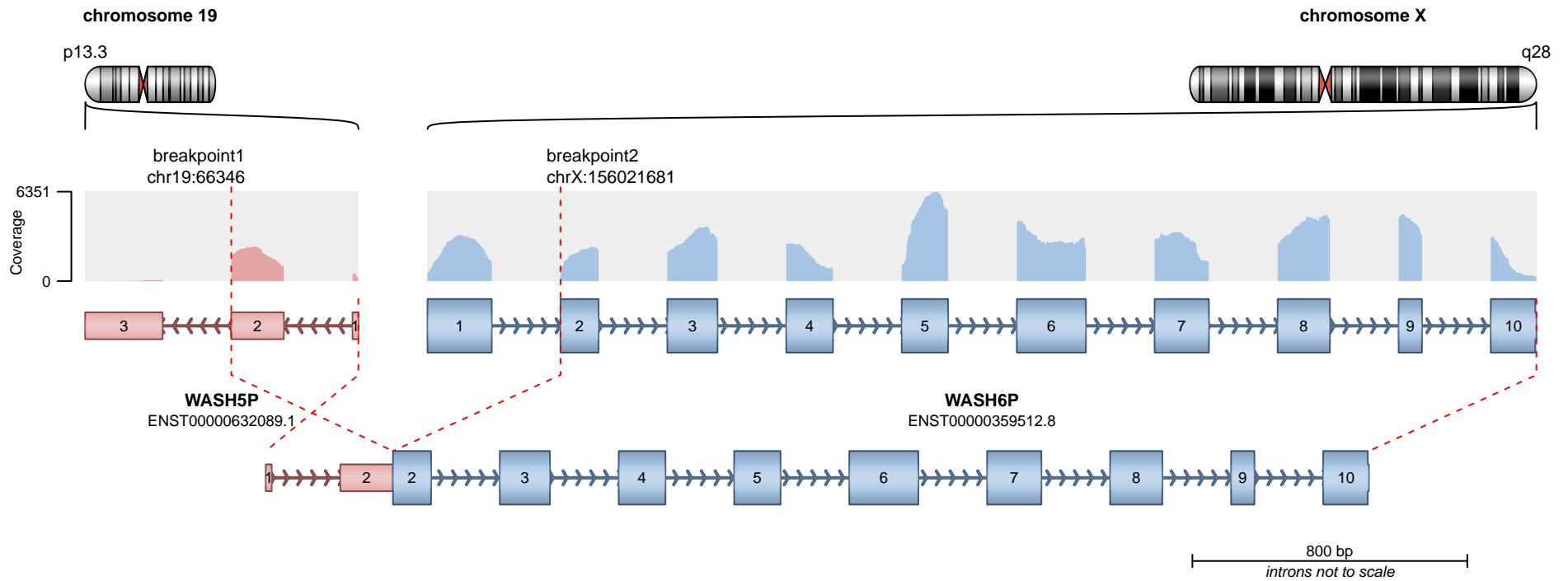

RETAINED PROTEIN DOMAINS
reading frame unclear



SUPPORTING READ COUNT

Split reads = 9
Discordant mates = 66

— translocation — deletion
— duplication — inversion

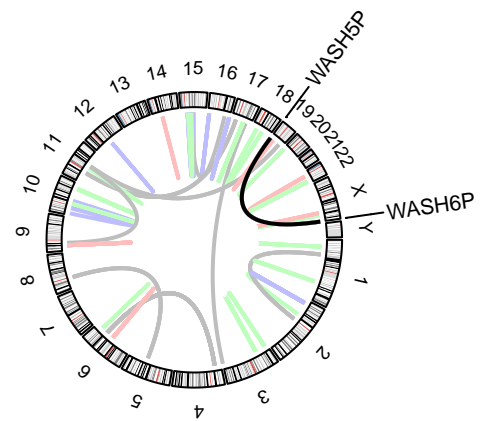
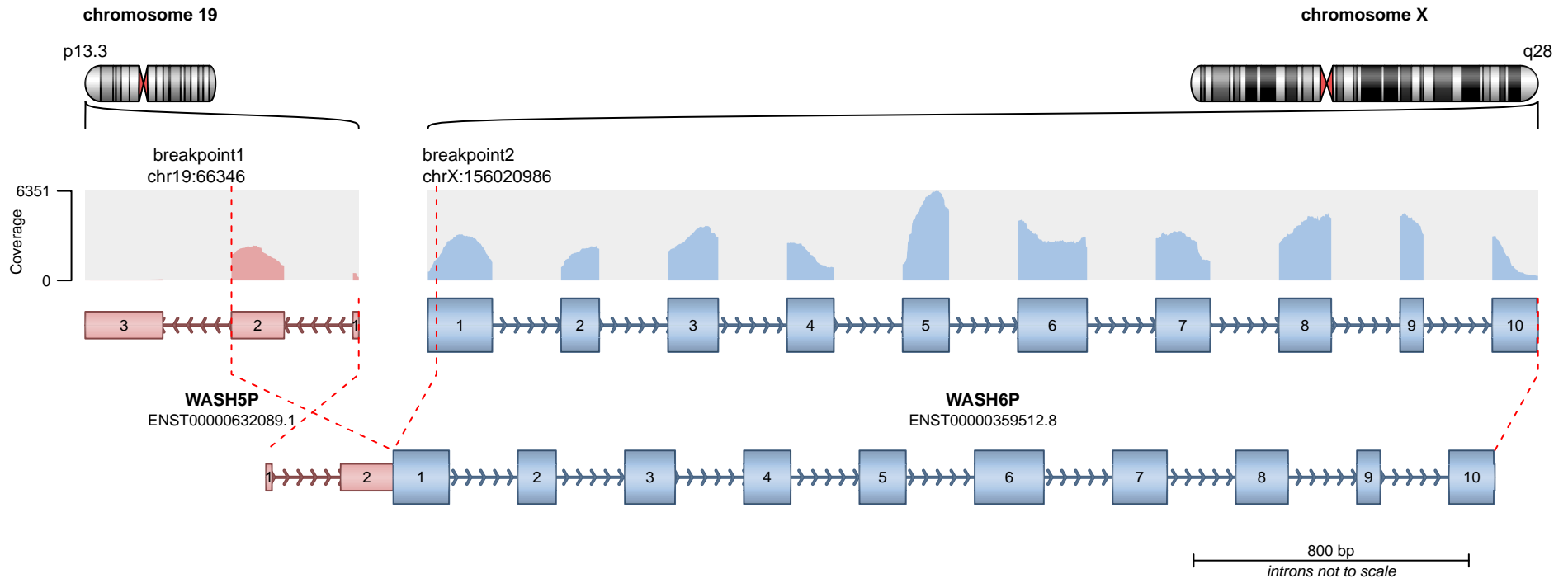

RETAINED PROTEIN DOMAINS
reading frame unclear



SUPPORTING READ COUNT

Split reads = 3
Discordant mates = 66

— translocation — deletion
— duplication — inversion

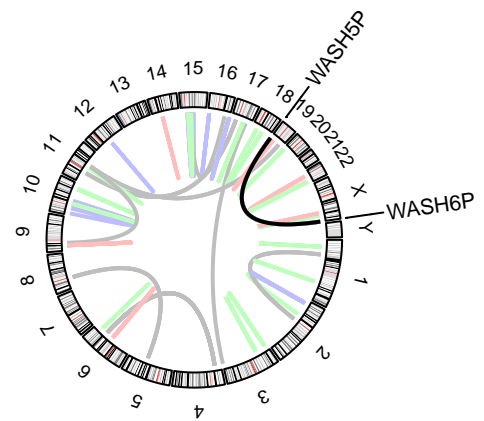
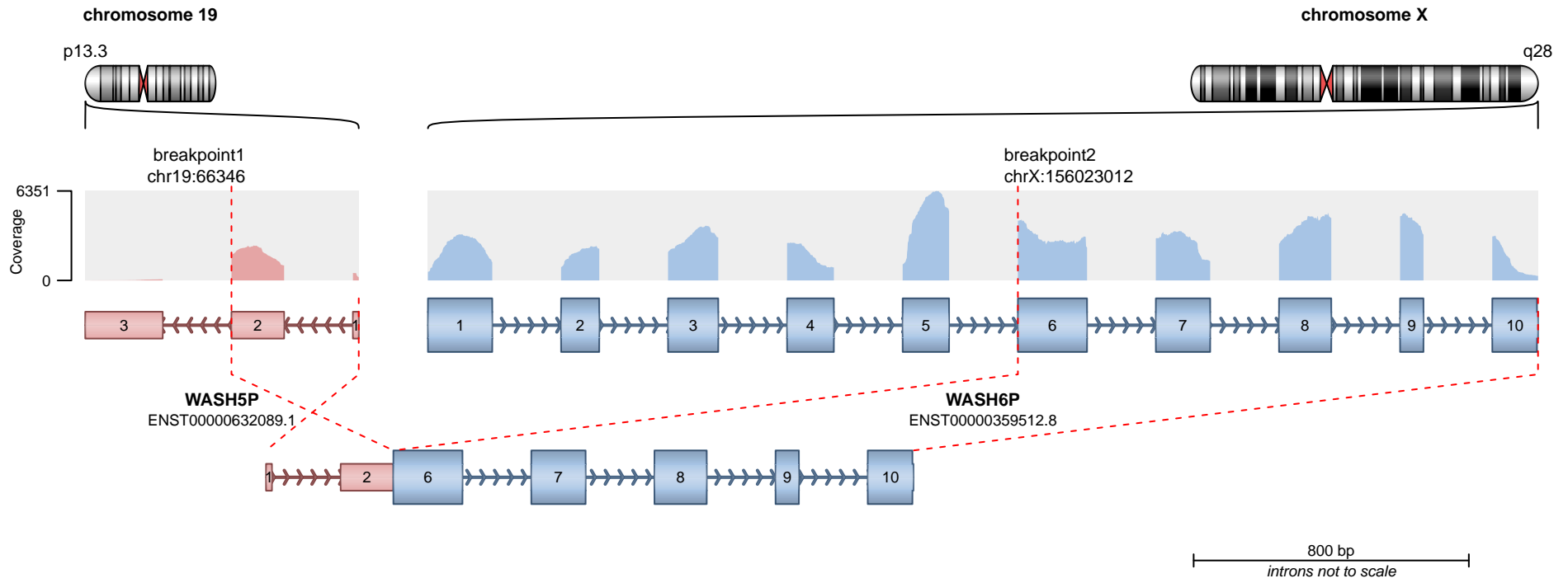

RETAINED PROTEIN DOMAINS
reading frame unclear

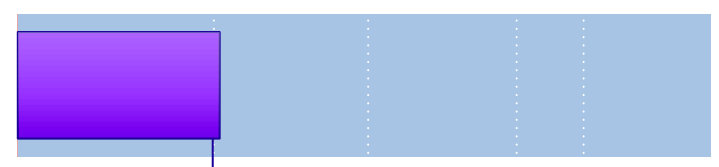

SUPPORTING READ COUNT

Split reads = 1
Discordant mates = 1

— translocation — deletion
— duplication — inversion

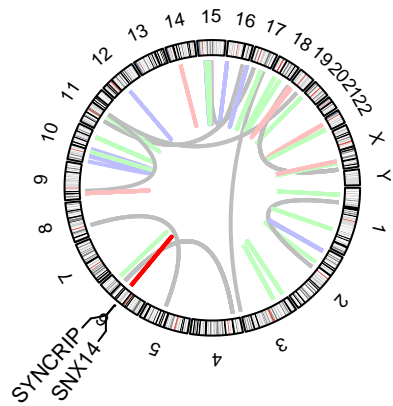
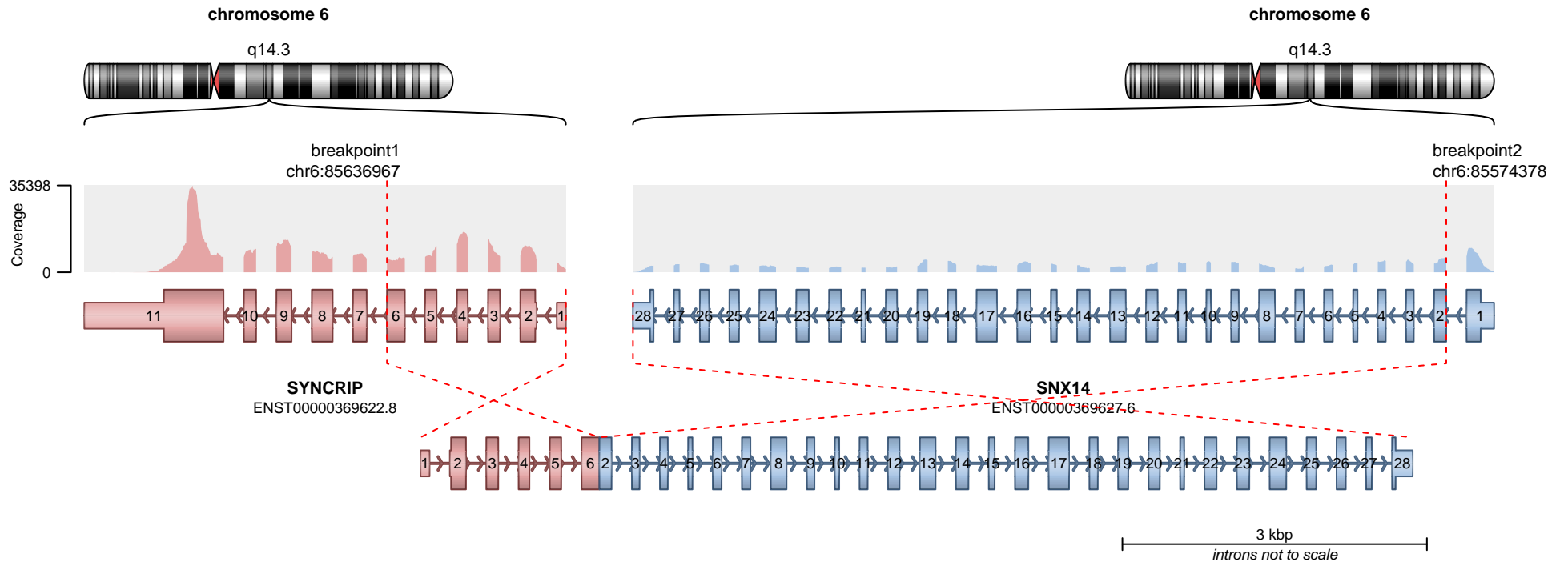

— translocation — deletion
— duplication — inversion

RETAINED PROTEIN DOMAINS
reading frame unclear

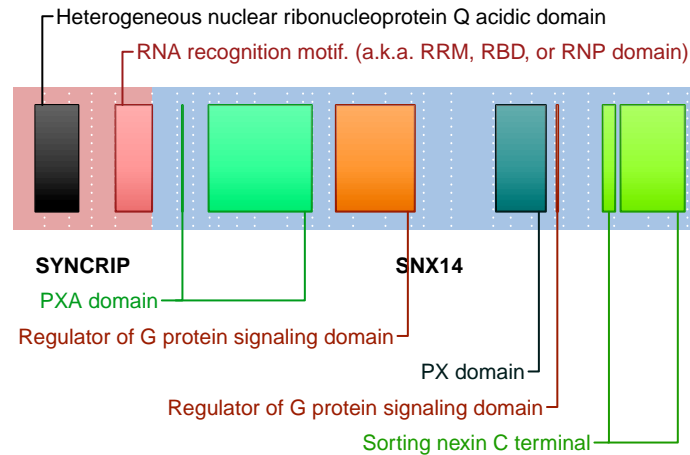

SUPPORTING READ COUNT

Split reads = 141
Discordant mates = 15

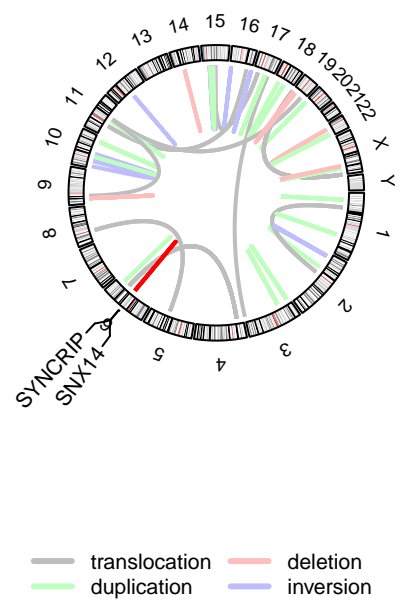
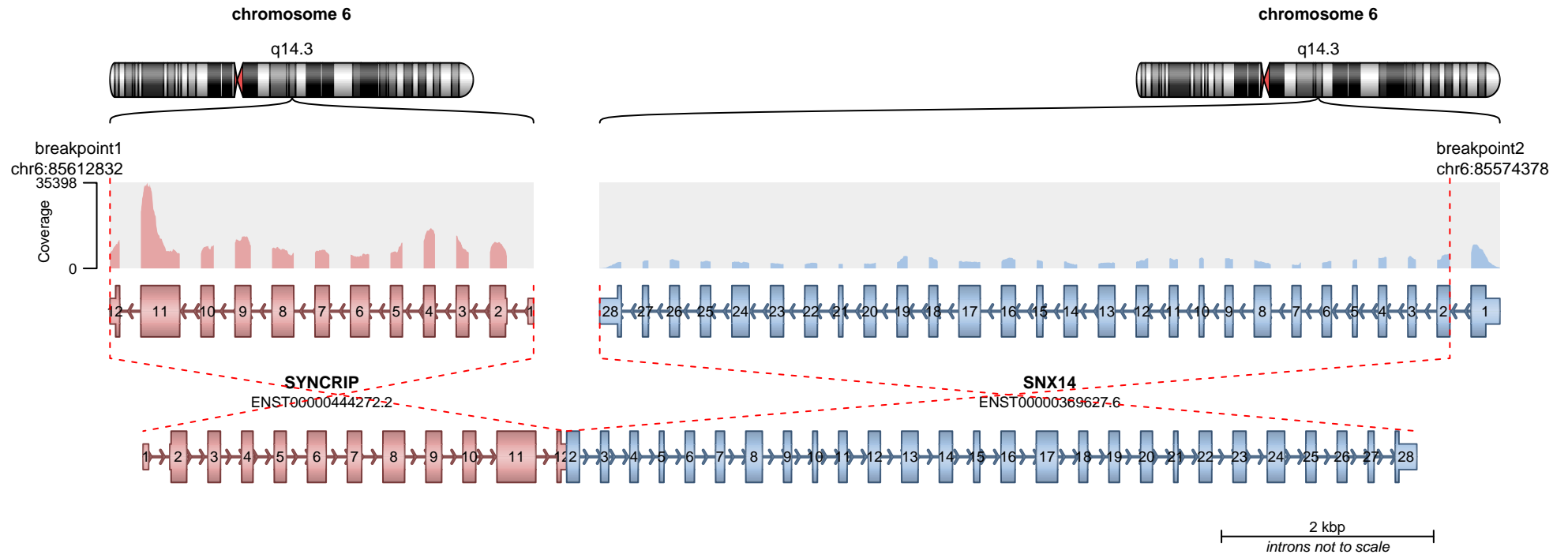

RETAINED PROTEIN DOMAINS
reading frame unclear

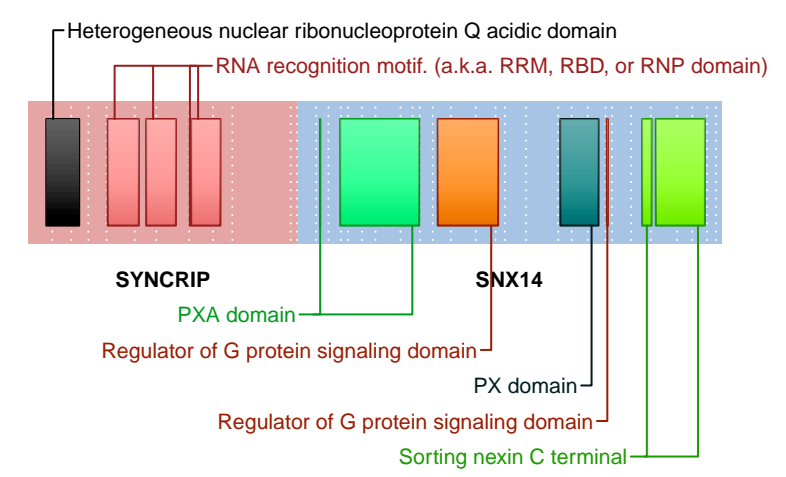

SUPPORTING READ COUNT

Split reads = 69
Discordant mates = 17

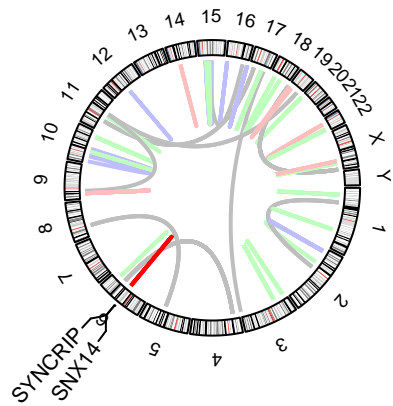
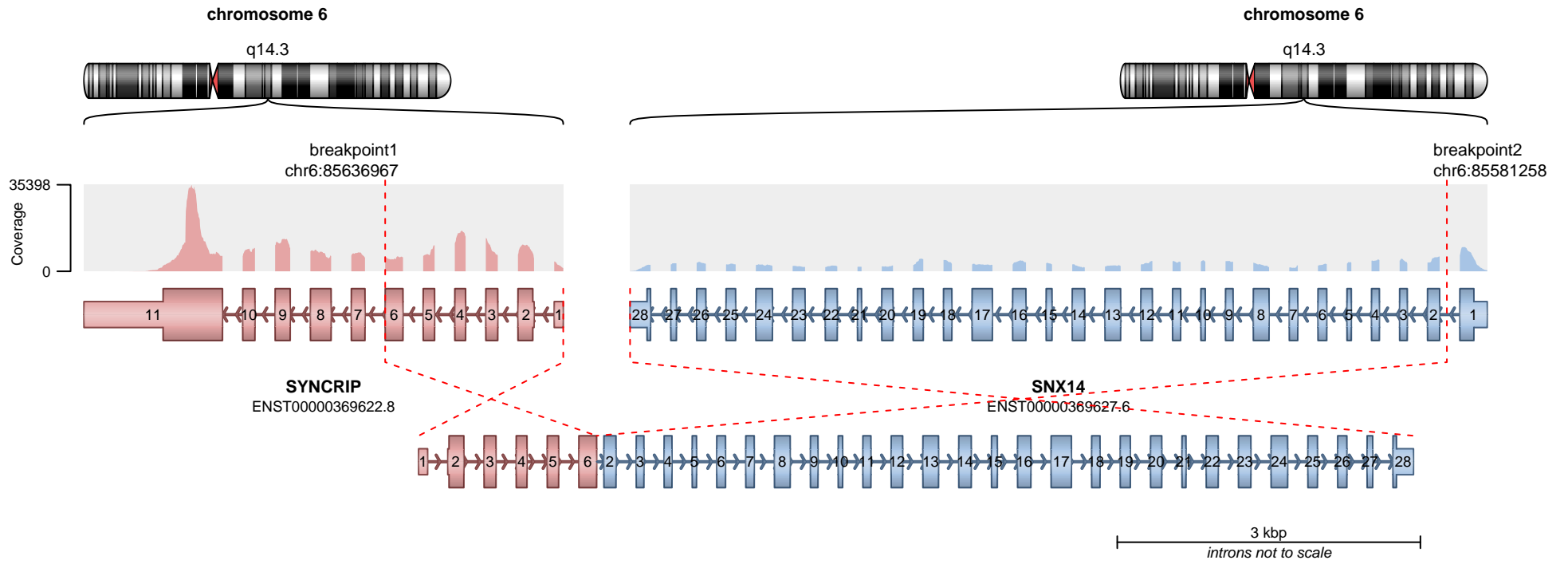

— translocation — deletion
— duplication — inversion

RETAINED PROTEIN DOMAINS
reading frame unclear

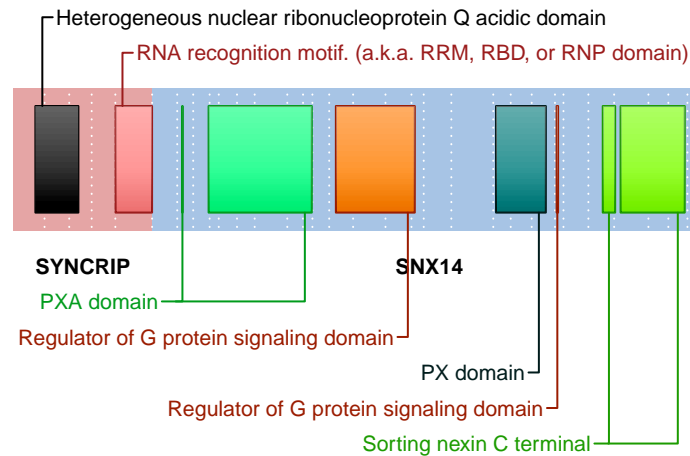

SUPPORTING READ COUNT

Split reads = 3
Discordant mates = 15

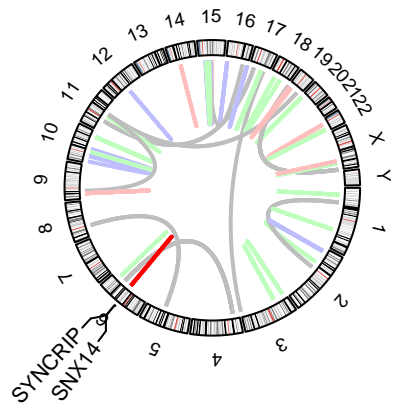
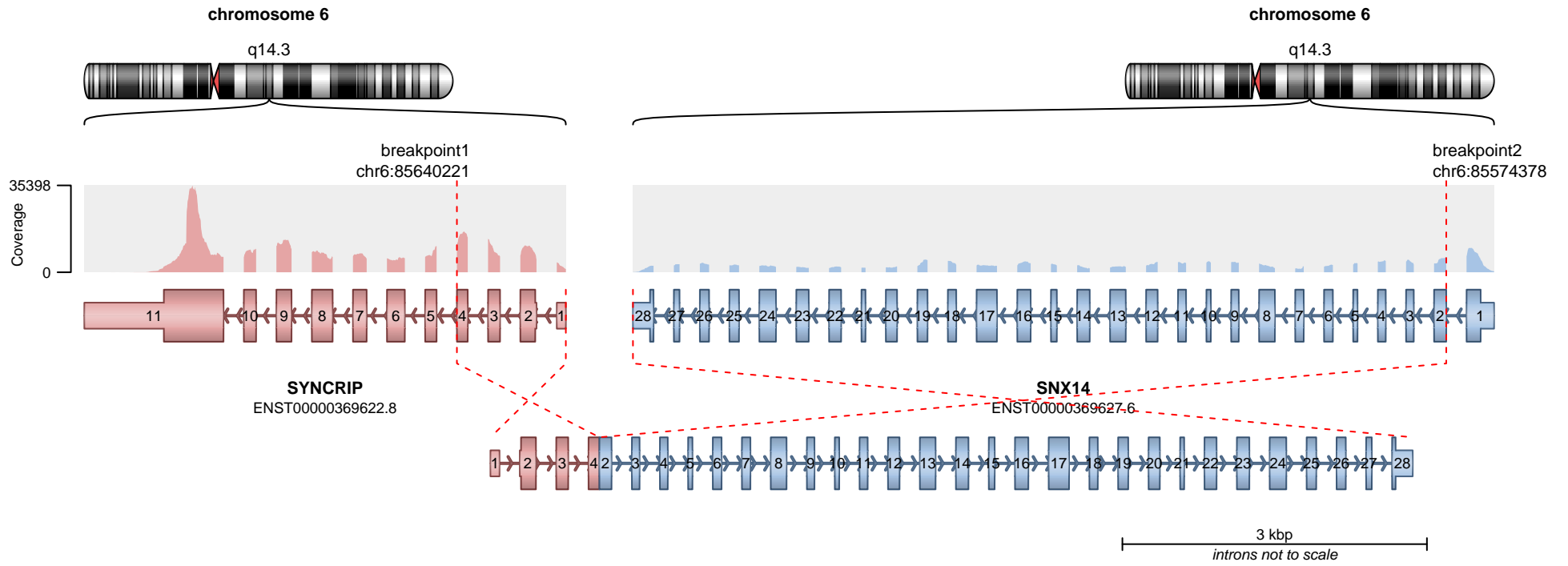

— translocation — deletion
— duplication — inversion

RETAINED PROTEIN DOMAINS
reading frame unclear

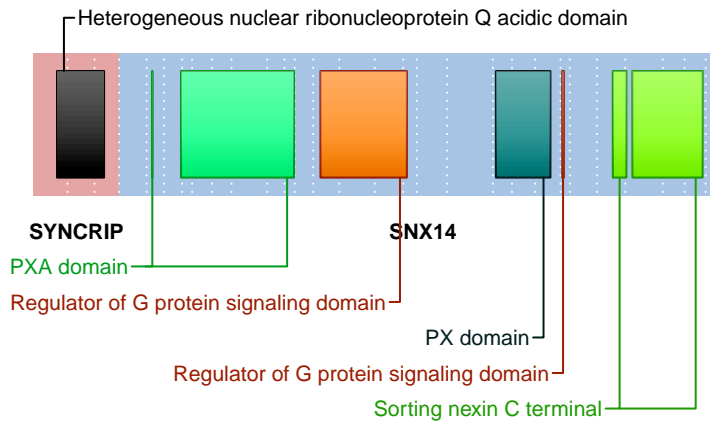

SUPPORTING READ COUNT

Split reads = 2
Discordant mates = 1

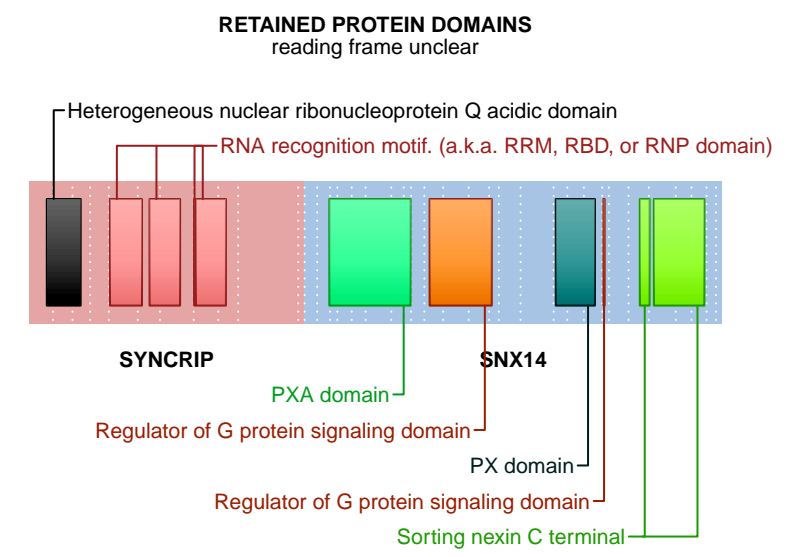
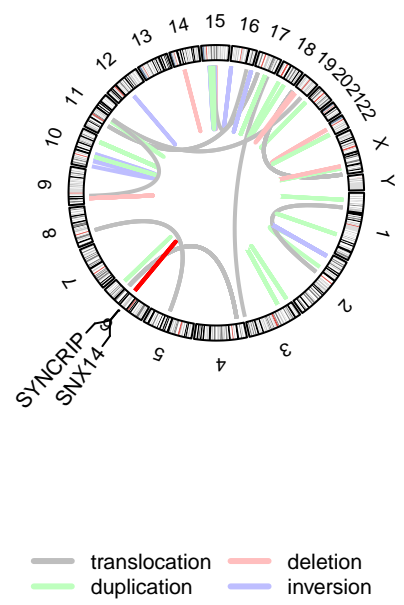
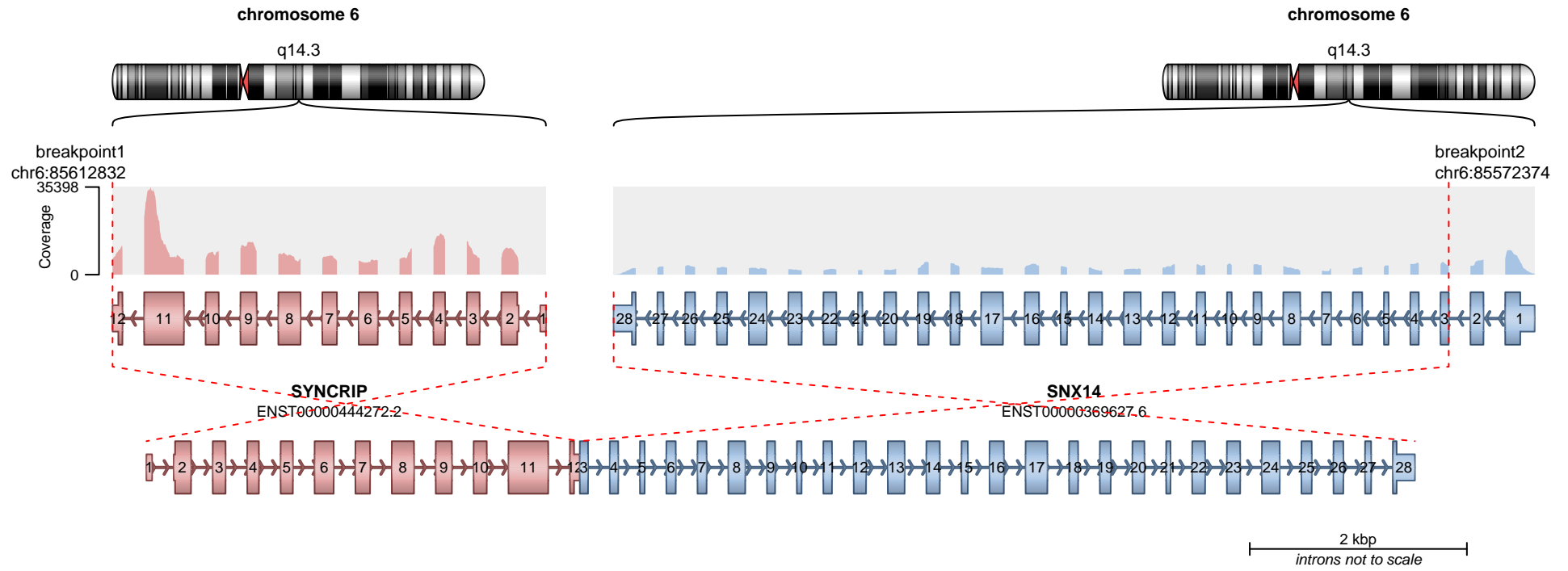

SUPPORTING READ COUNT

Split reads = 1
Discordant mates = 3

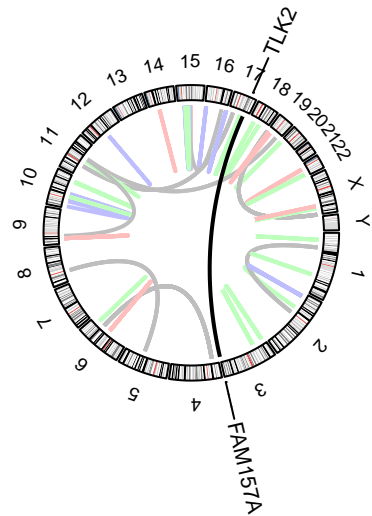
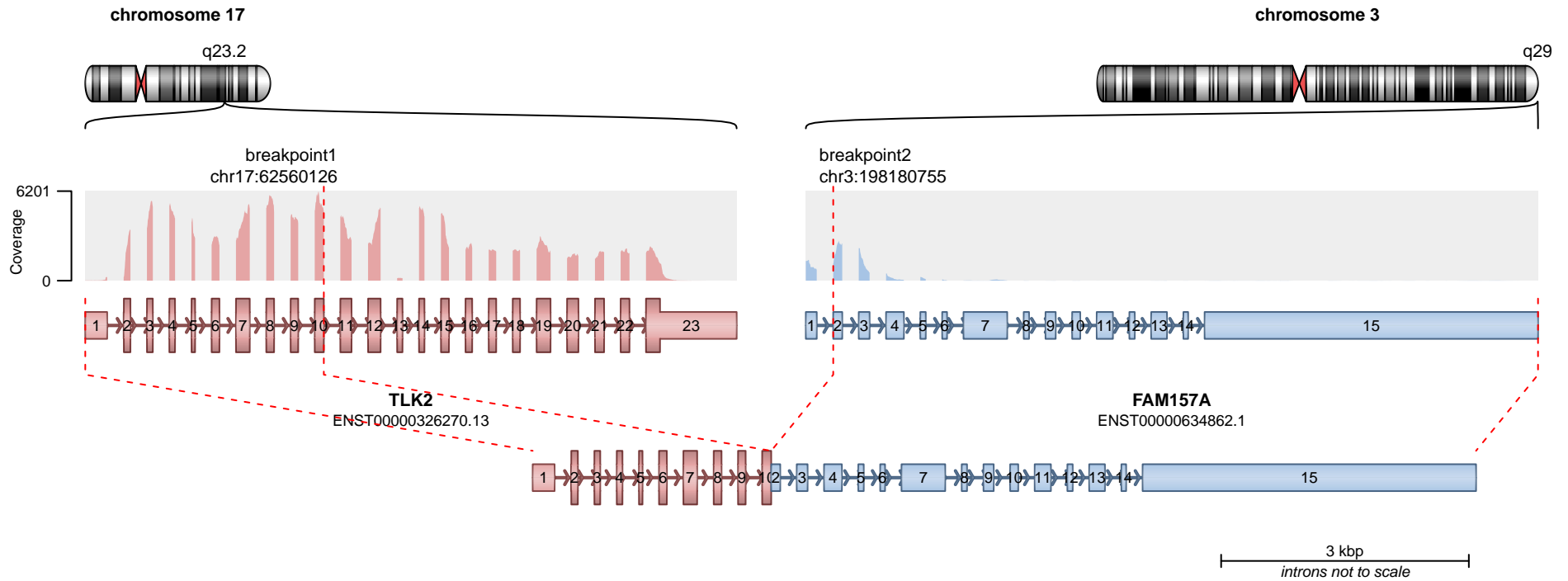

— translocation — deletion
— duplication — inversion

No protein domains retained in fusion.

SUPPORTING READ COUNT

Split reads = 123
Discordant mates = 2

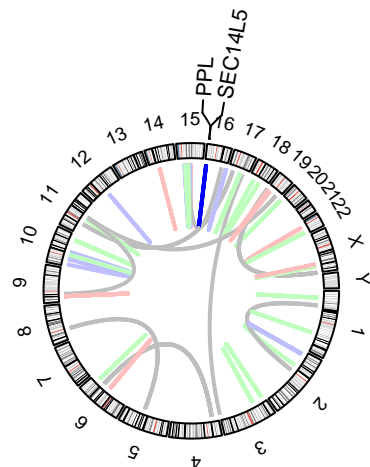
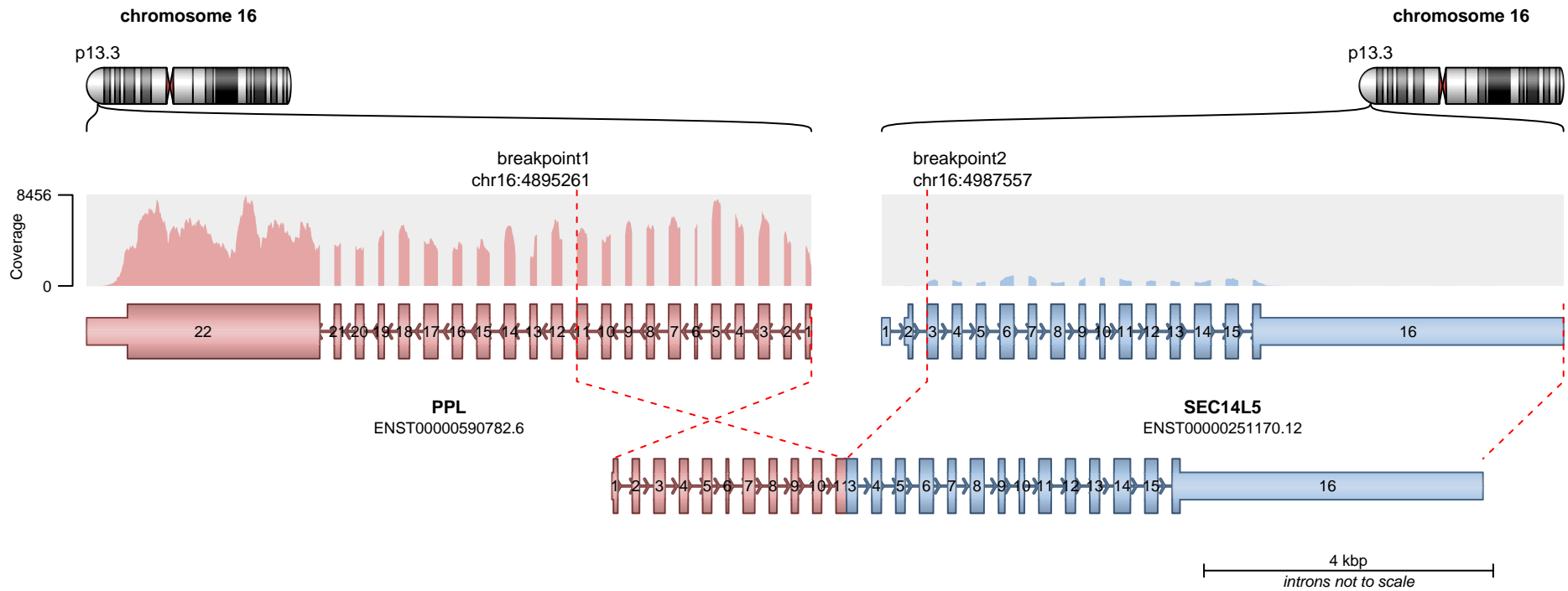

RETAINED PROTEIN DOMAINS
reading frame unclear

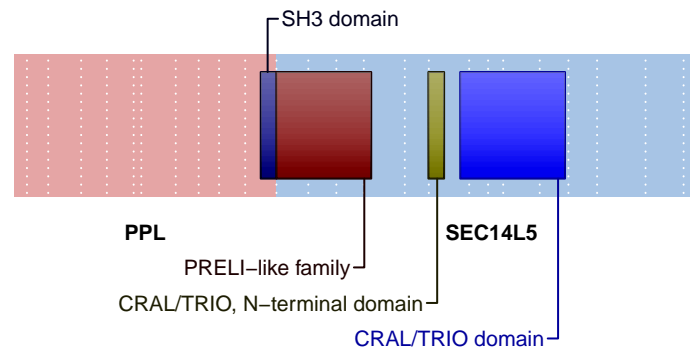

SUPPORTING READ COUNT

Split reads = 110
Discordant mates = 13

- translocation
- duplication
- deletion
- inversion

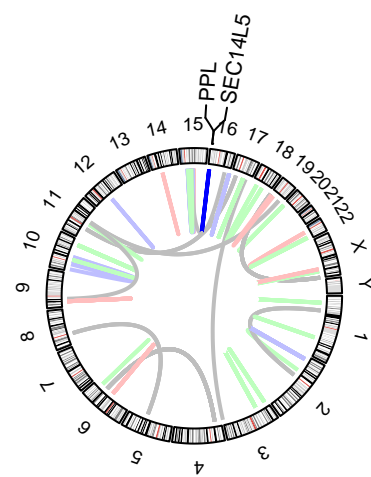
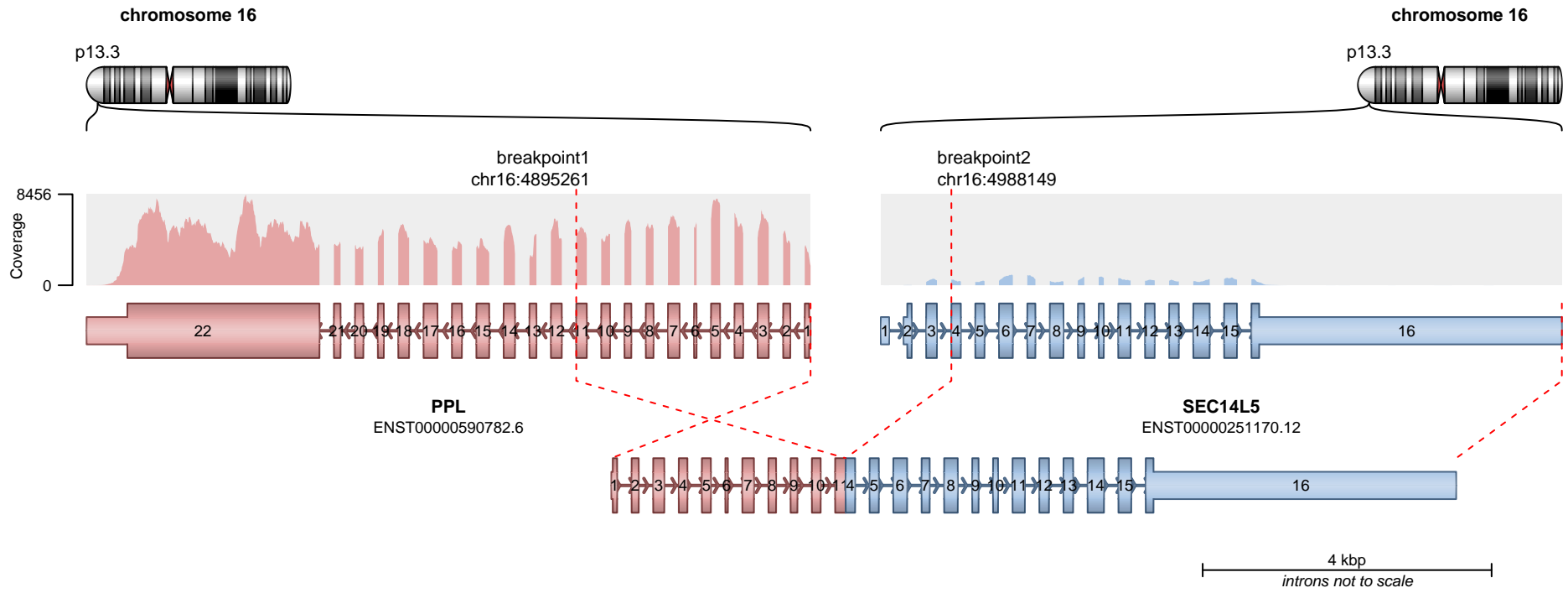

RETAINED PROTEIN DOMAINS
reading frame unclear

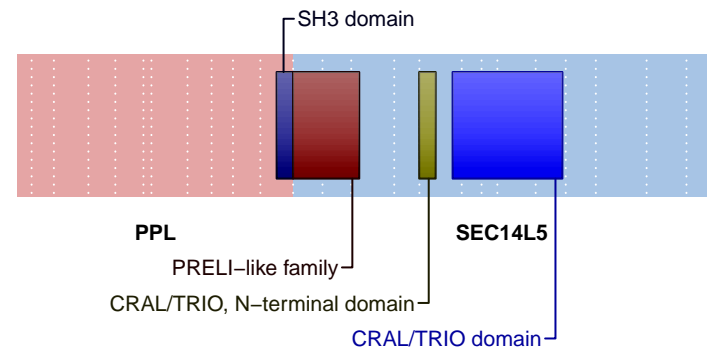

SUPPORTING READ COUNT

Split reads = 6
Discordant mates = 1

- translocation
- duplication
- deletion
- inversion

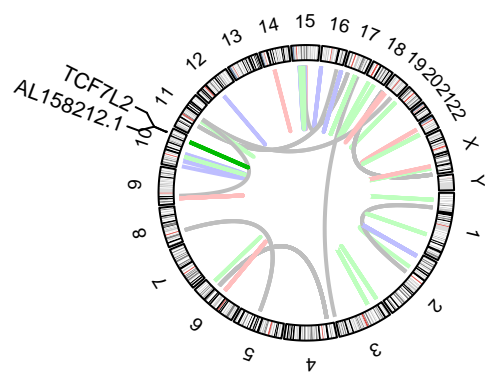
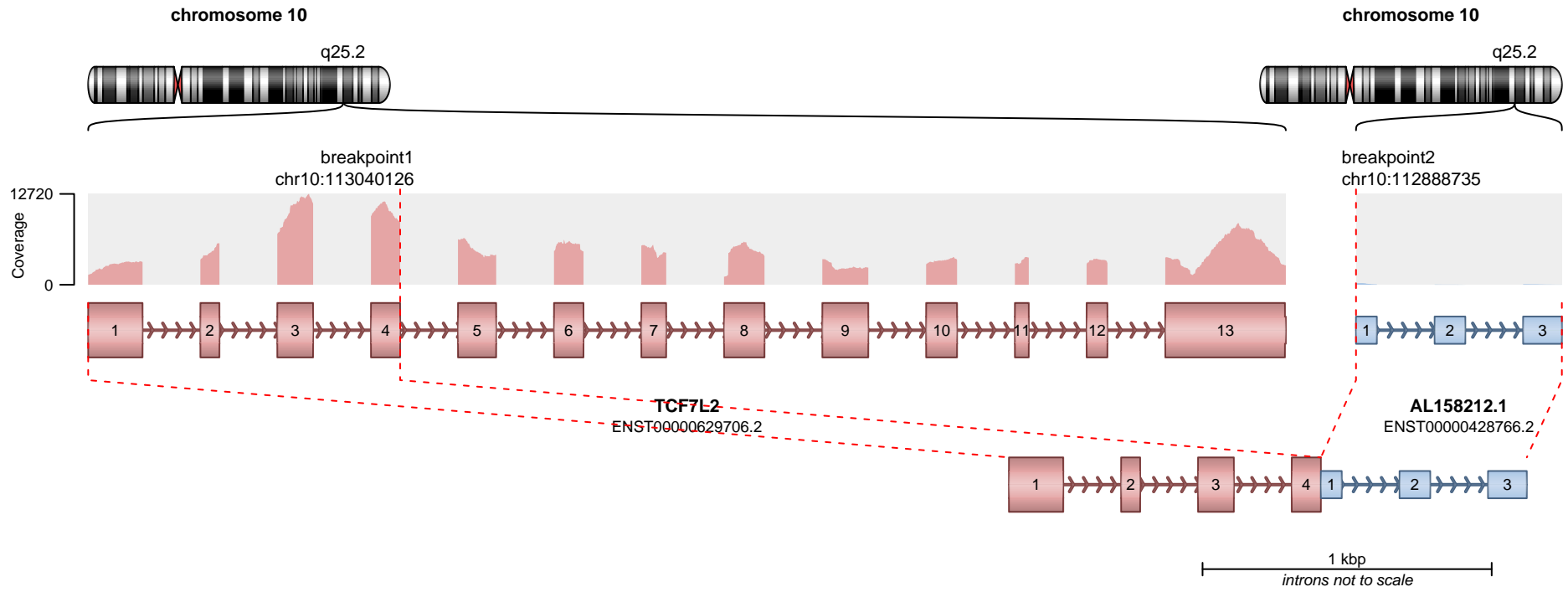

RETAINED PROTEIN DOMAINS
reading frame unclear

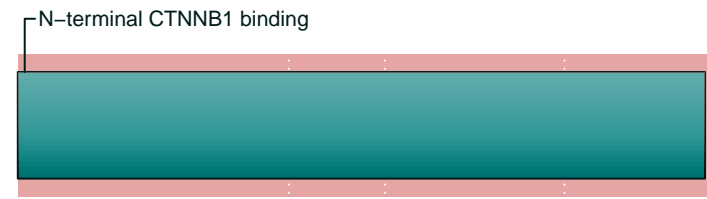

TCF7L2

SUPPORTING READ COUNT

Split reads = 104
Discordant mates = 10

- translocation
- duplication
- deletion
- inversion

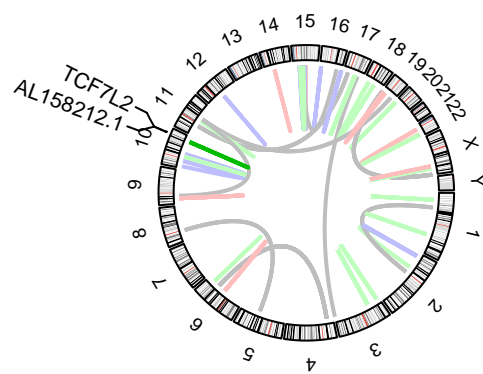
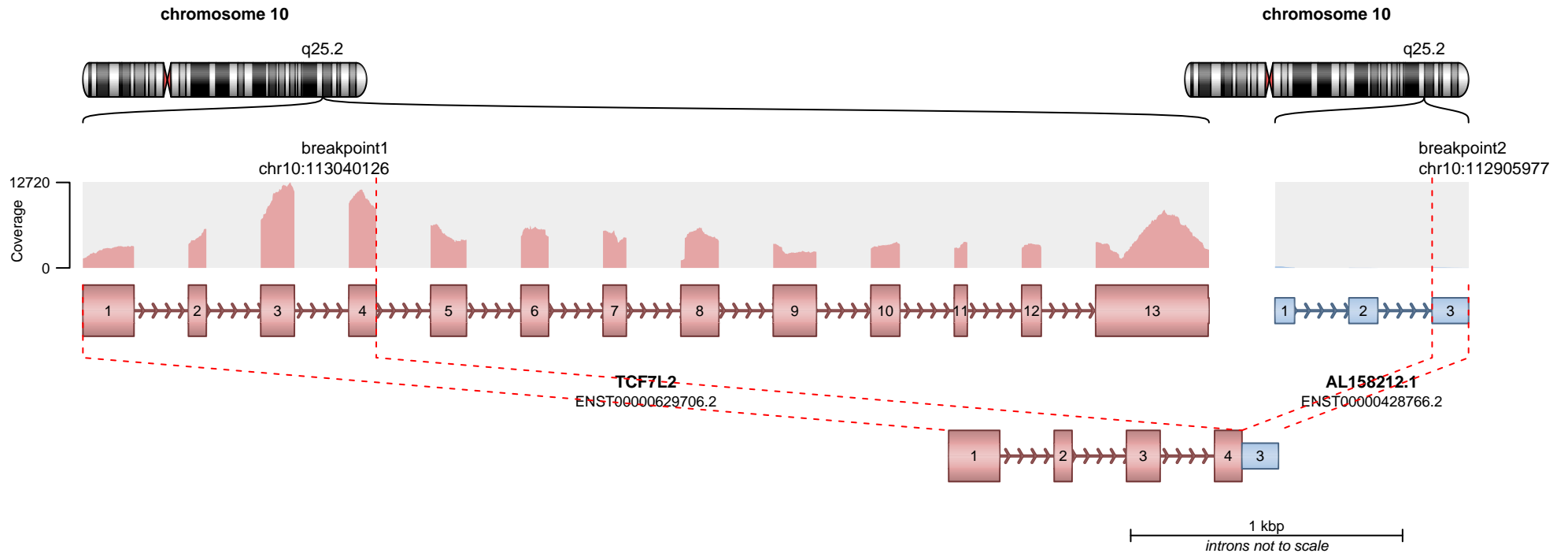

RETAINED PROTEIN DOMAINS
reading frame unclear

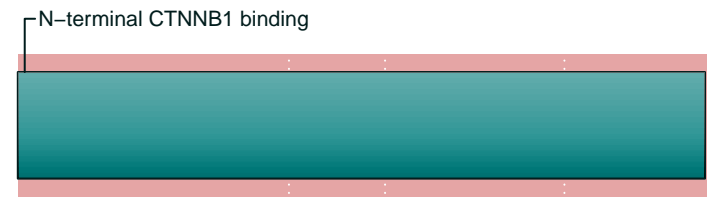

SUPPORTING READ COUNT

Split reads = 39
Discordant mates = 5

- translocation
- duplication
- deletion
- inversion

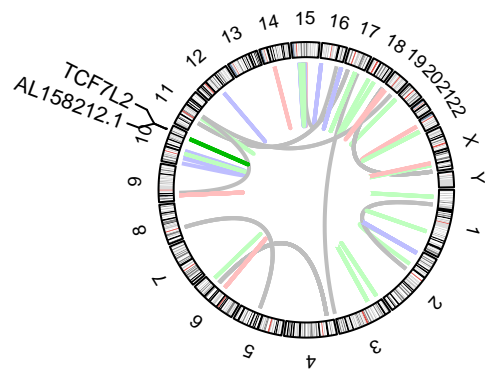
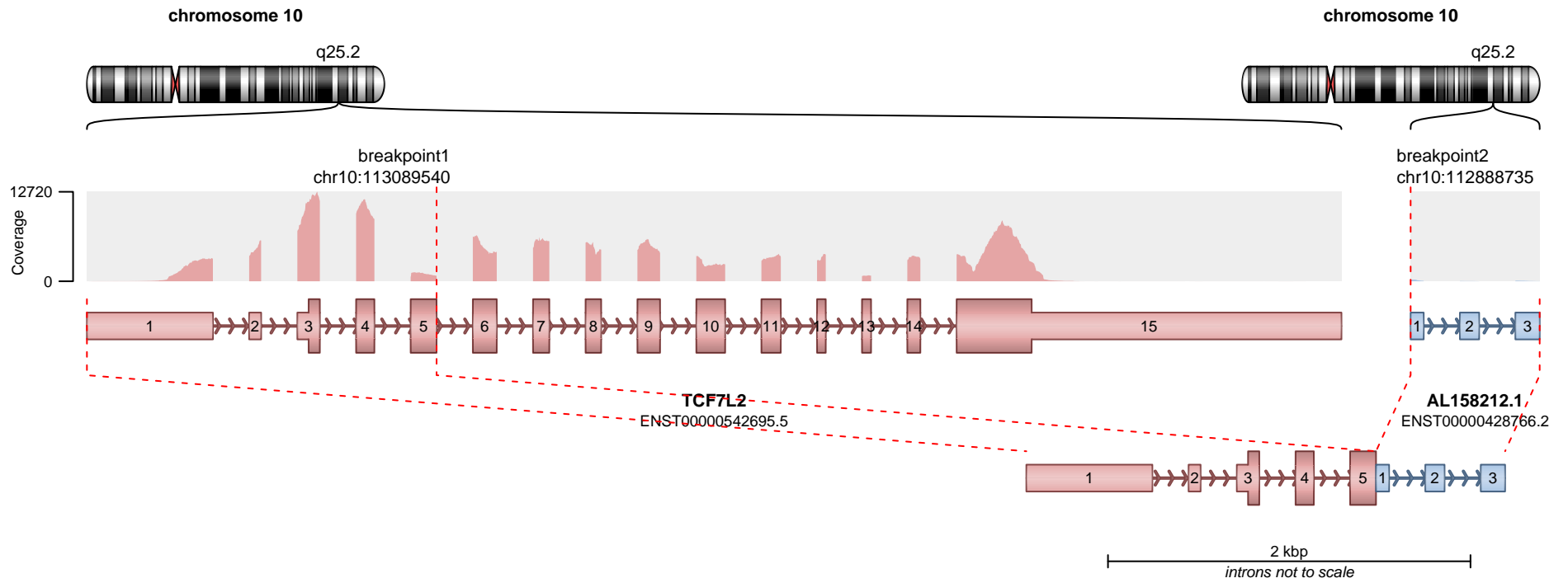

RETAINED PROTEIN DOMAINS
reading frame unclear

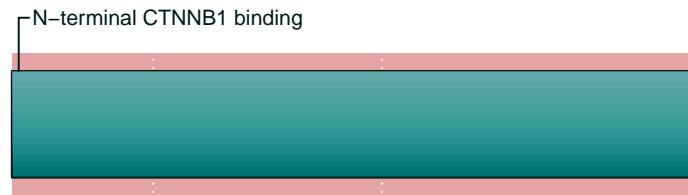

TCF7L2

SUPPORTING READ COUNT

Split reads = 13
Discordant mates = 10

- translocation
- duplication
- deletion
- inversion

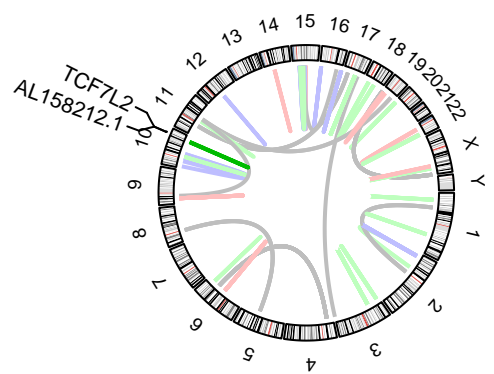
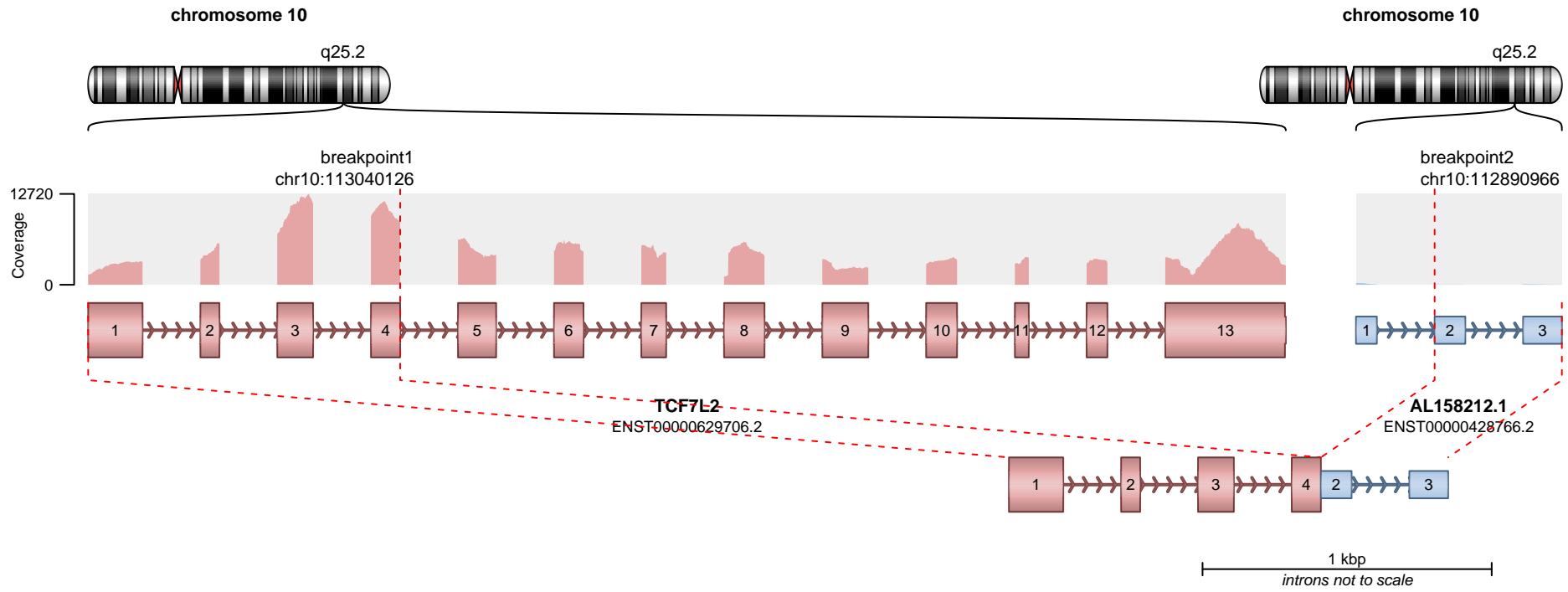

RETAINED PROTEIN DOMAINS
reading frame unclear

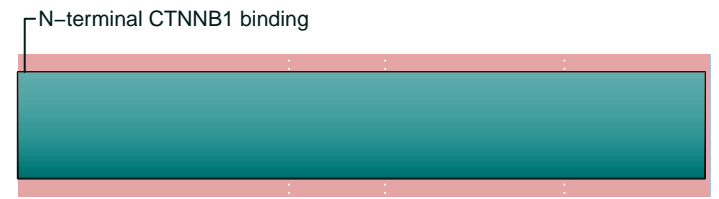

SUPPORTING READ COUNT

Split reads = 3
Discordant mates = 5

- translocation
- duplication
- deletion
- inversion

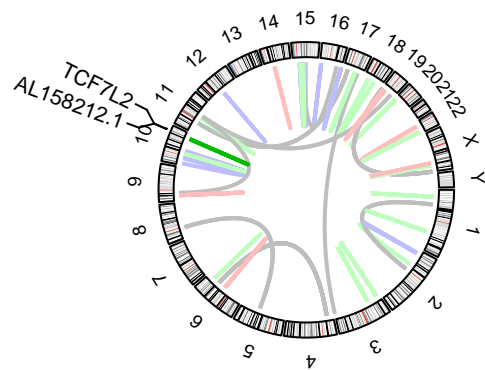
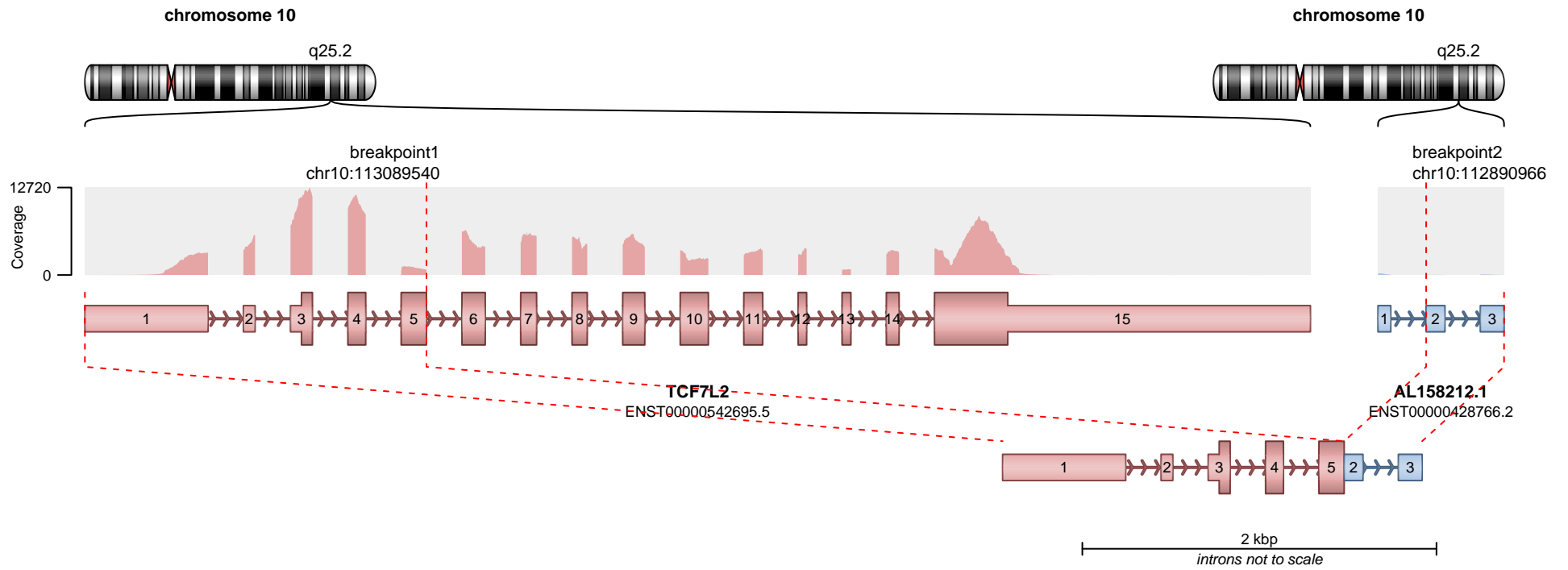

RETAINED PROTEIN DOMAINS
reading frame unclear

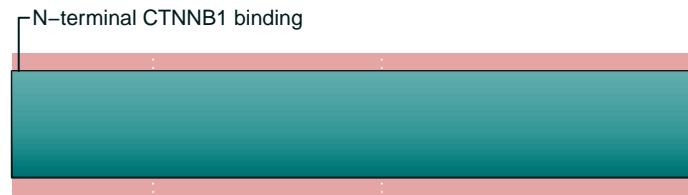

SUPPORTING READ COUNT

Split reads = 1
Discordant mates = 5

- translocation
- duplication
- deletion
- inversion

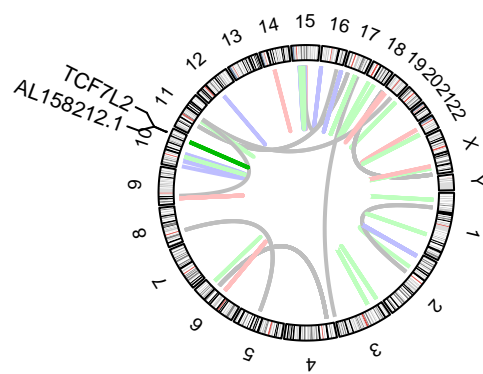
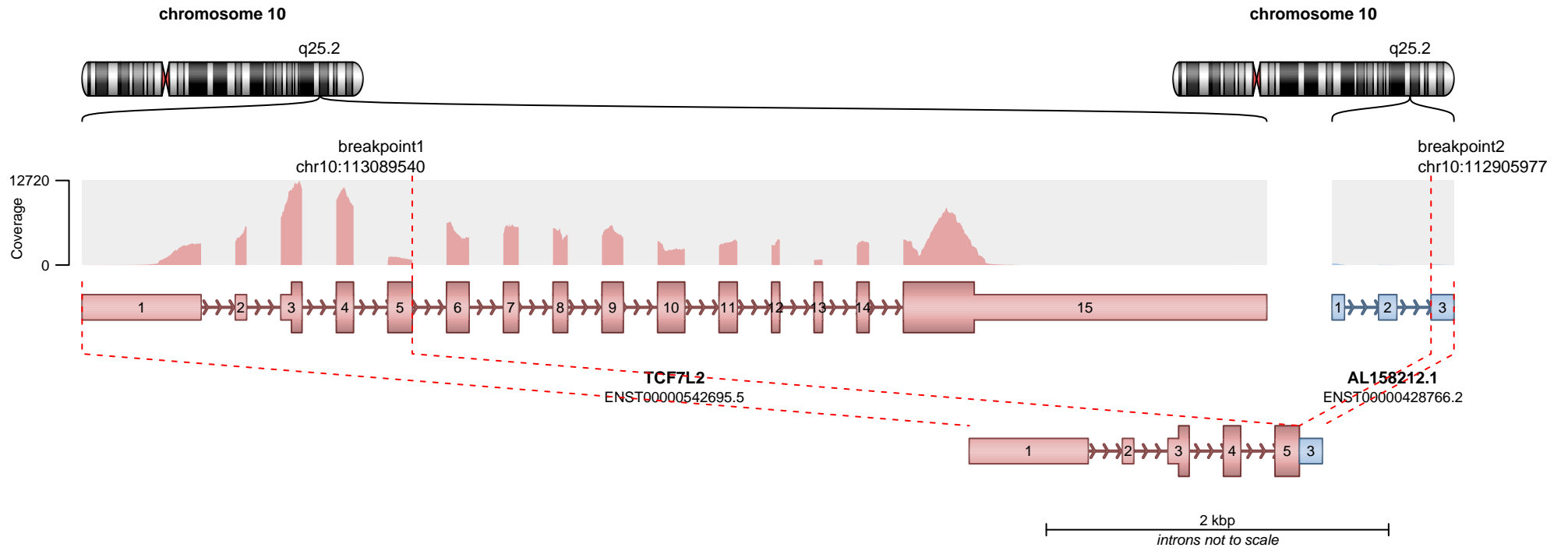

RETAINED PROTEIN DOMAINS
reading frame unclear

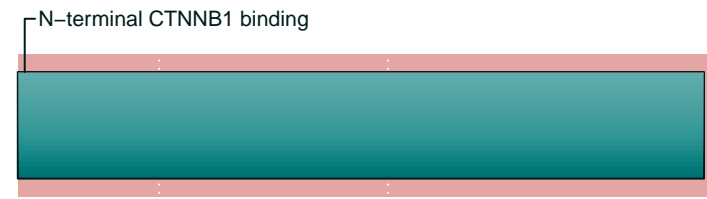

SUPPORTING READ COUNT

Split reads = 1
Discordant mates = 5

— translocation — deletion
— duplication — inversion

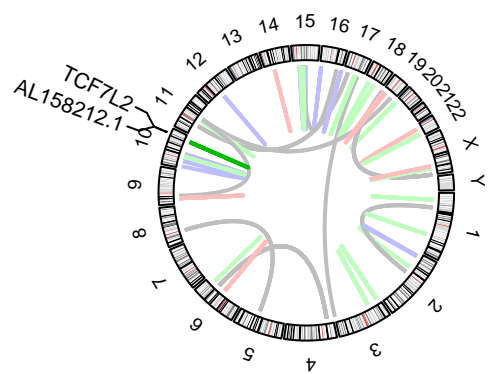
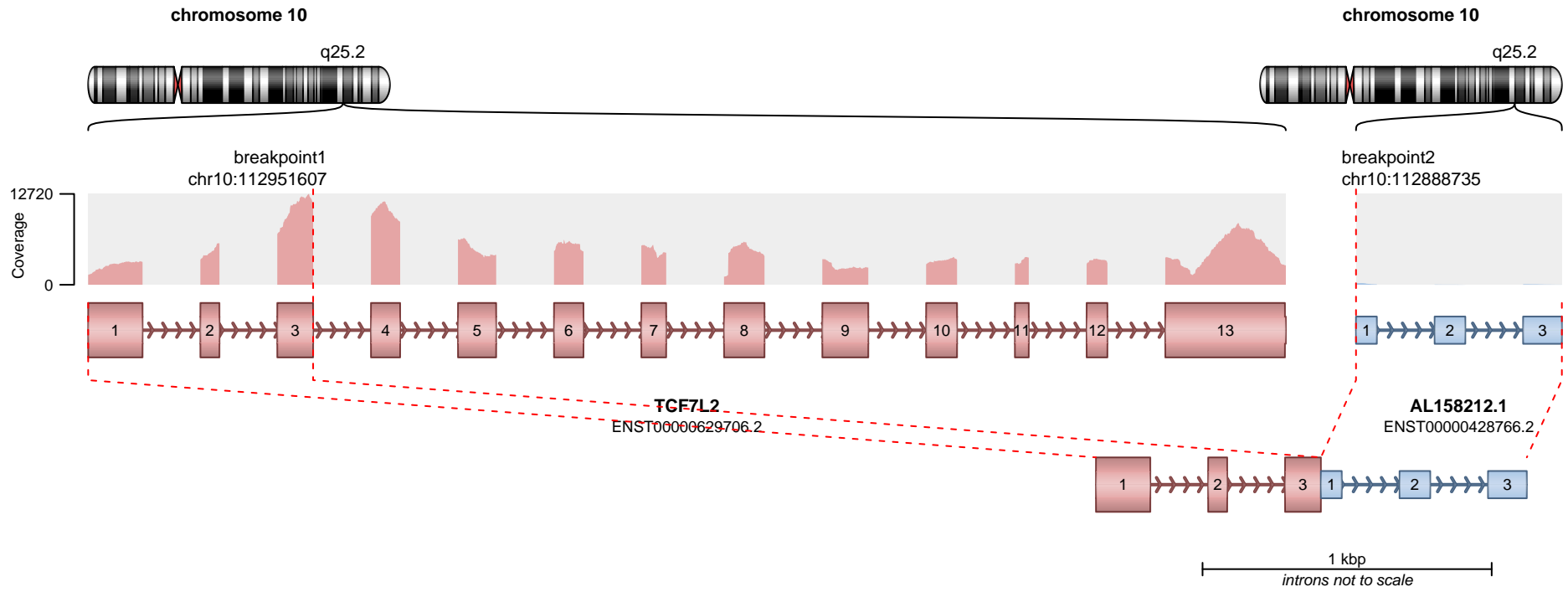

RETAINED PROTEIN DOMAINS
reading frame unclear

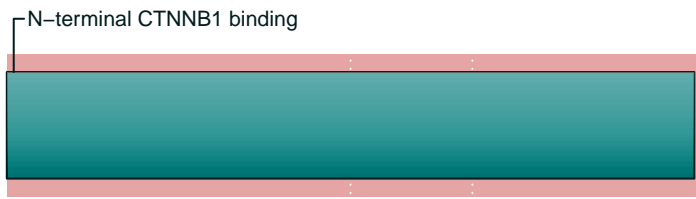

SUPPORTING READ COUNT

Split reads = 1
Discordant mates = 0

- translocation
- duplication
- deletion
- inversion

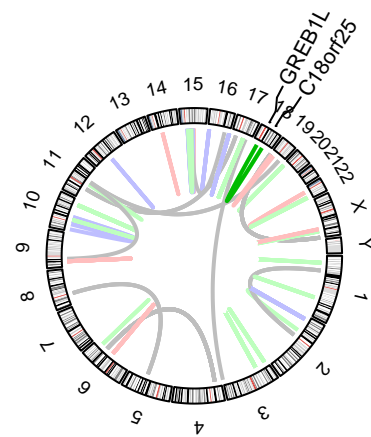
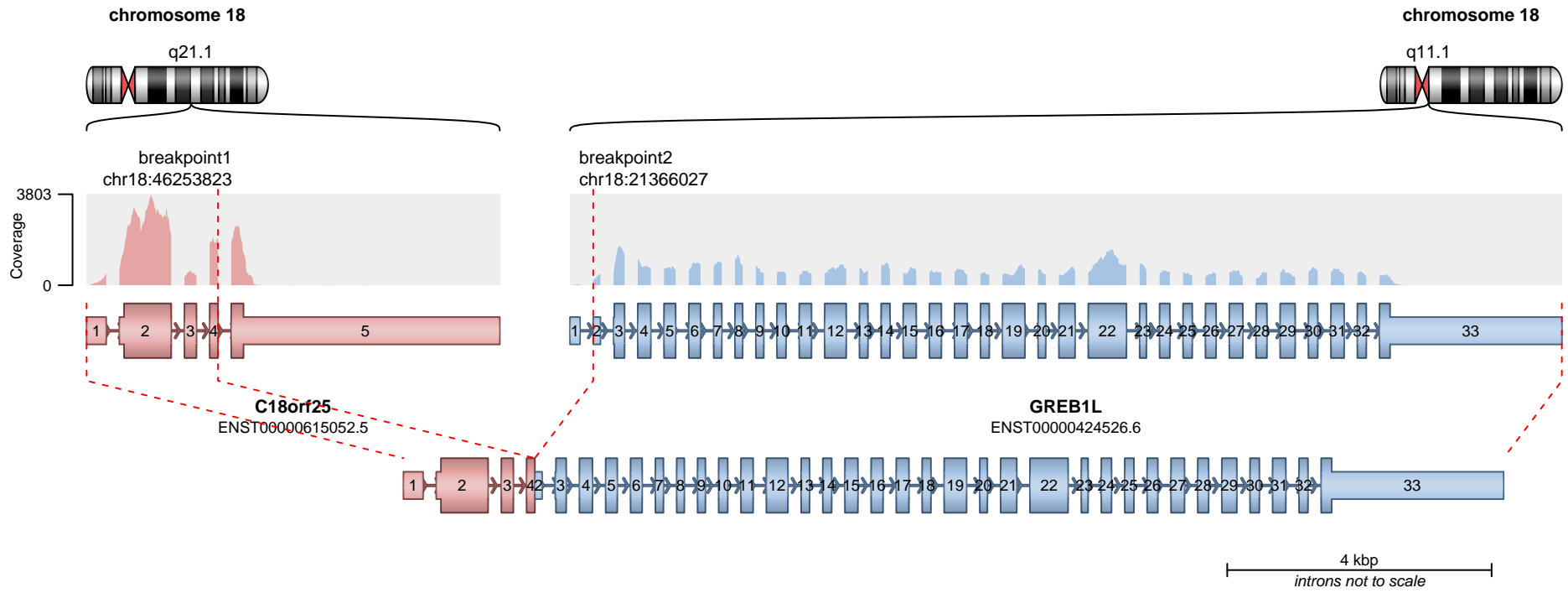

RETAINED PROTEIN DOMAINS
reading frame unclear

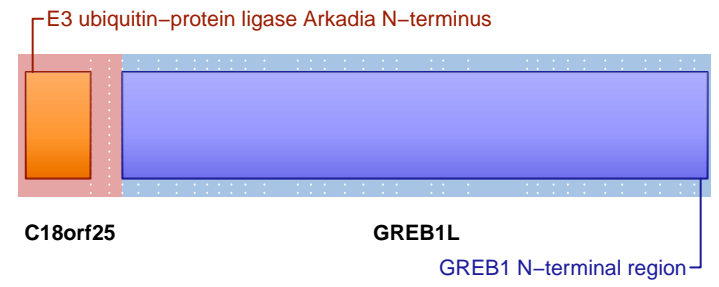

SUPPORTING READ COUNT

Split reads = 100
Discordant mates = 9

- translocation
- duplication
- deletion
- inversion

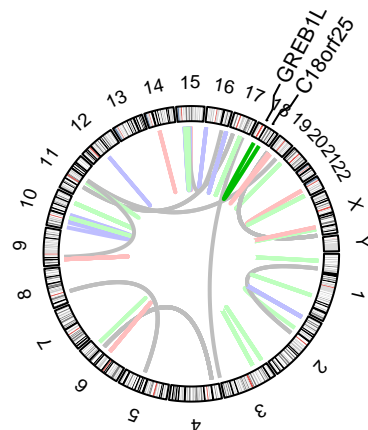
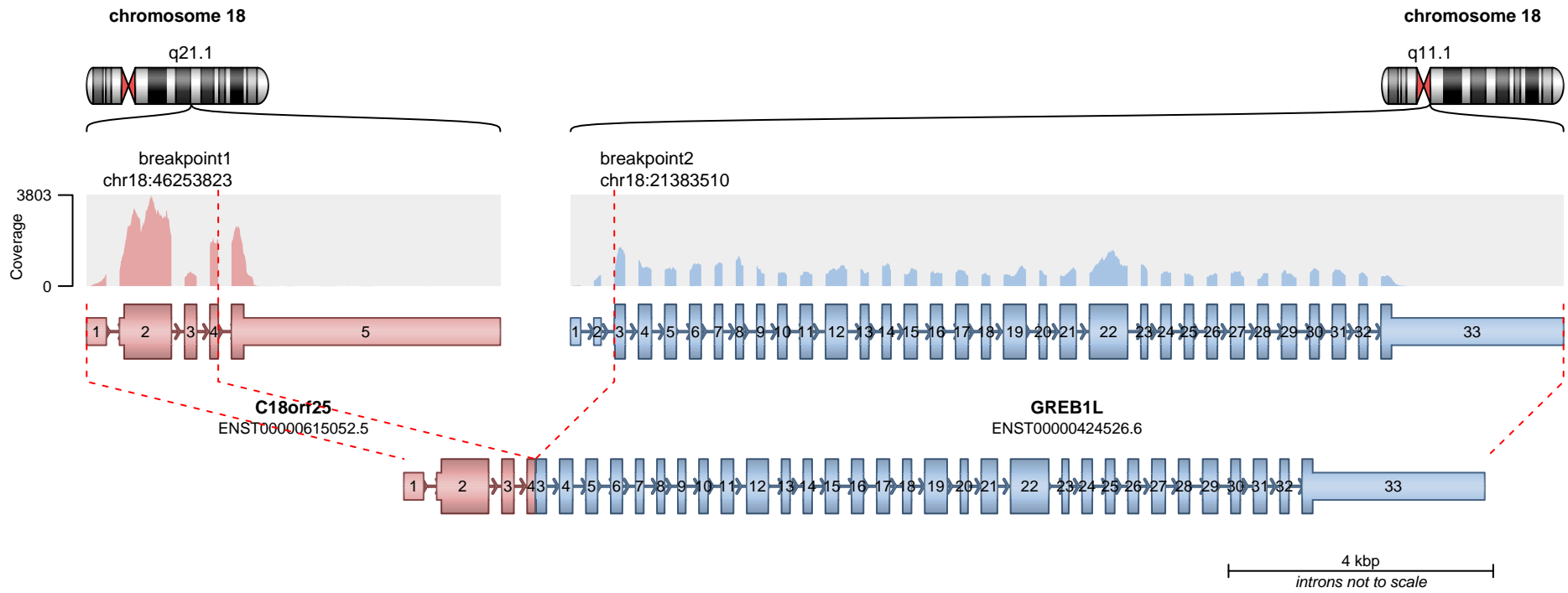

RETAINED PROTEIN DOMAINS
reading frame unclear

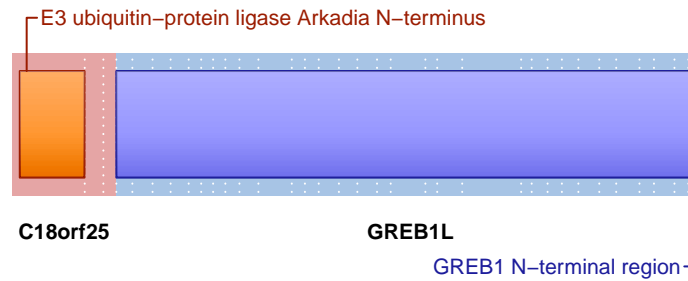

SUPPORTING READ COUNT

Split reads = 3
Discordant mates = 4

— translocation — deletion
— duplication — inversion

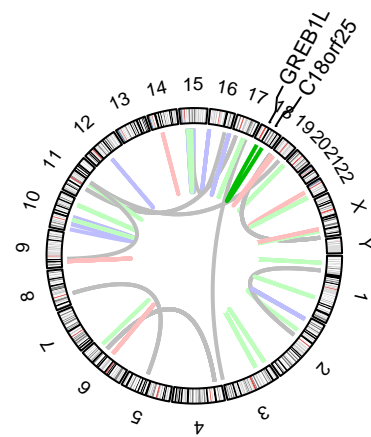
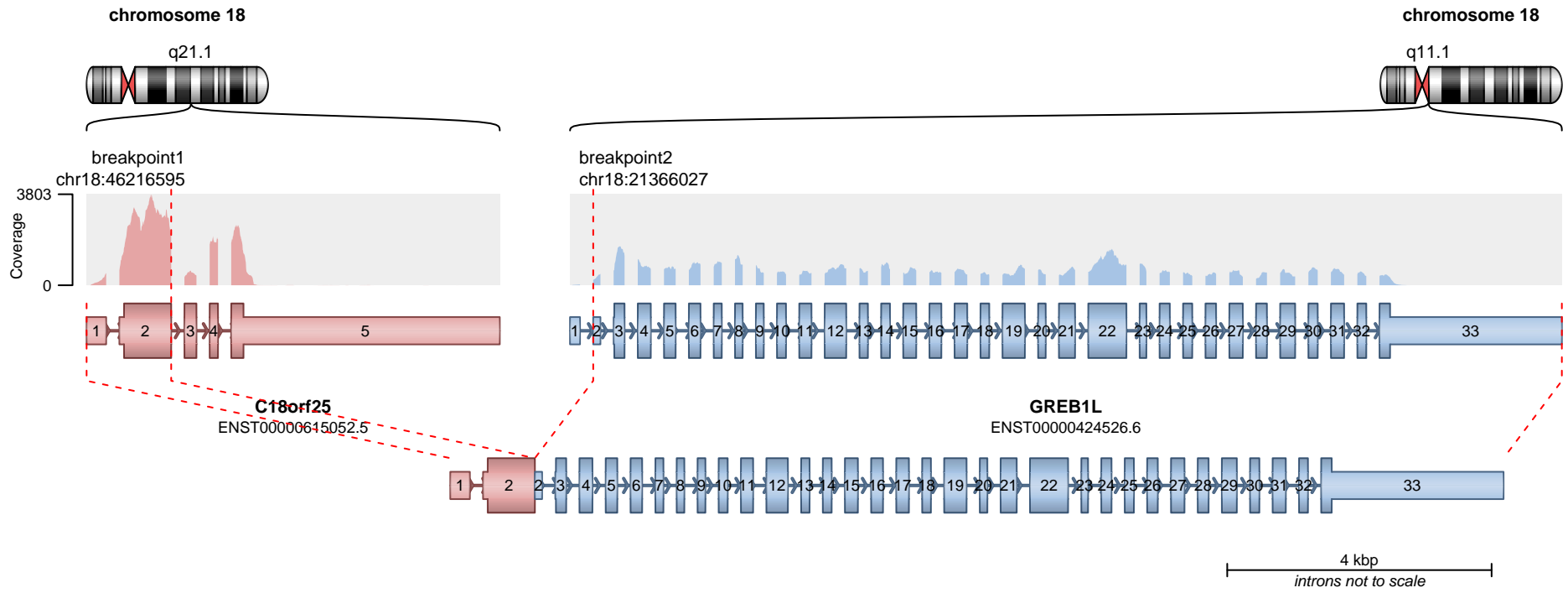

RETAINED PROTEIN DOMAINS
reading frame unclear

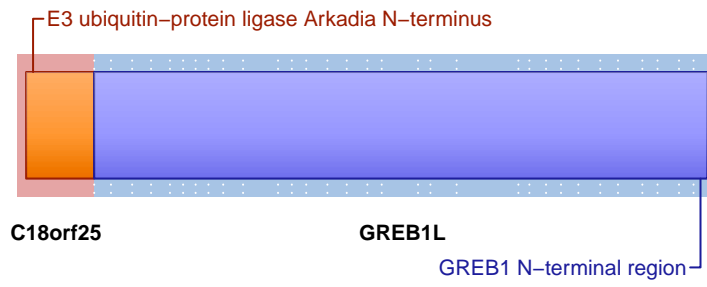

SUPPORTING READ COUNT

Split reads = 1
Discordant mates = 0

— translocation — deletion
— duplication — inversion

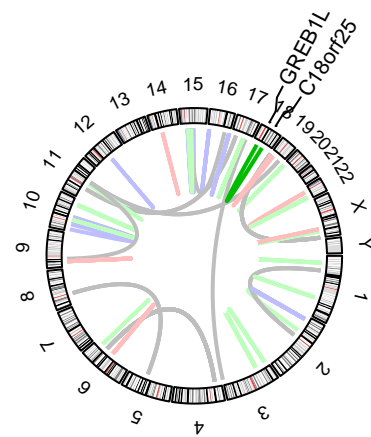
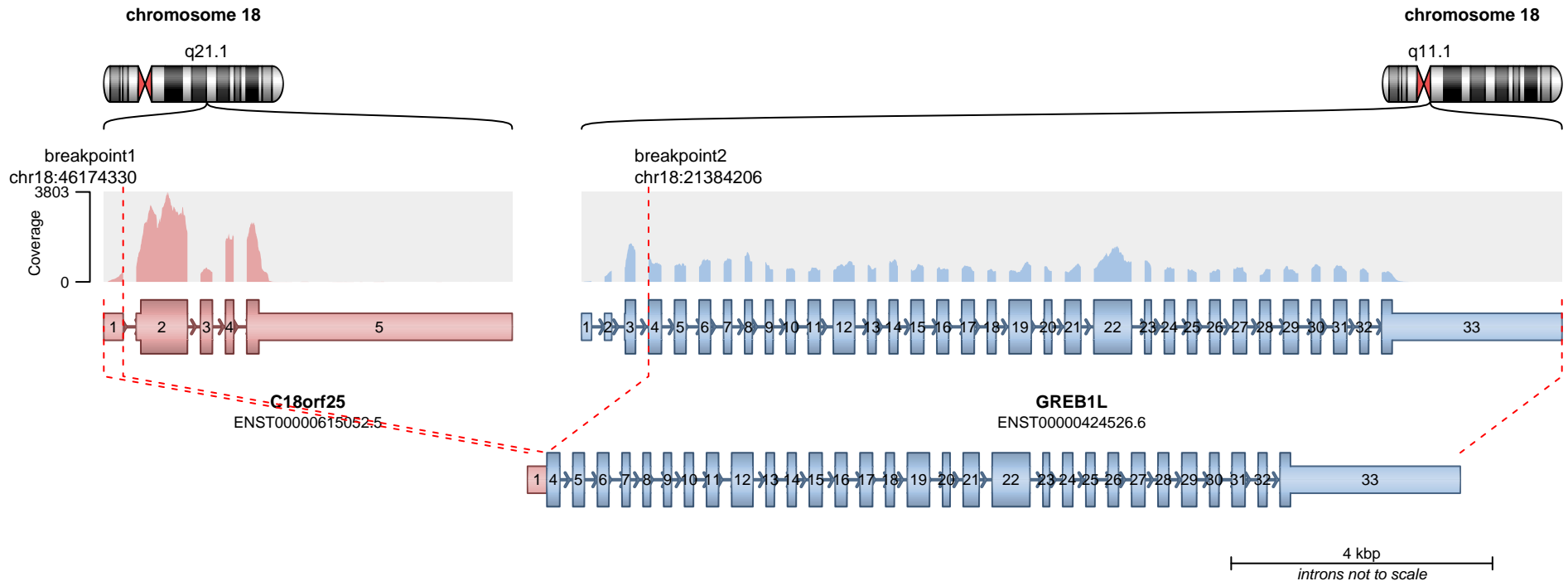

— translocation — deletion
— duplication — inversion

RETAINED PROTEIN DOMAINS
reading frame unclear

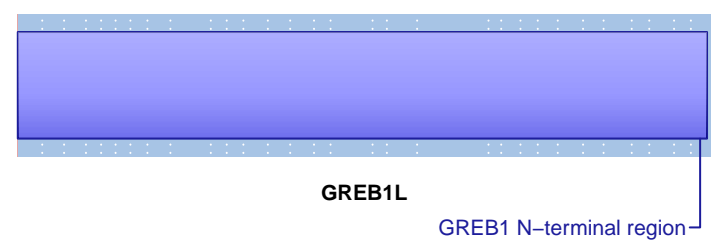

SUPPORTING READ COUNT

Split reads = 1
Discordant mates = 0

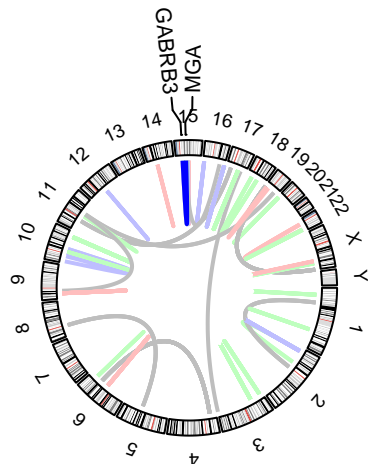
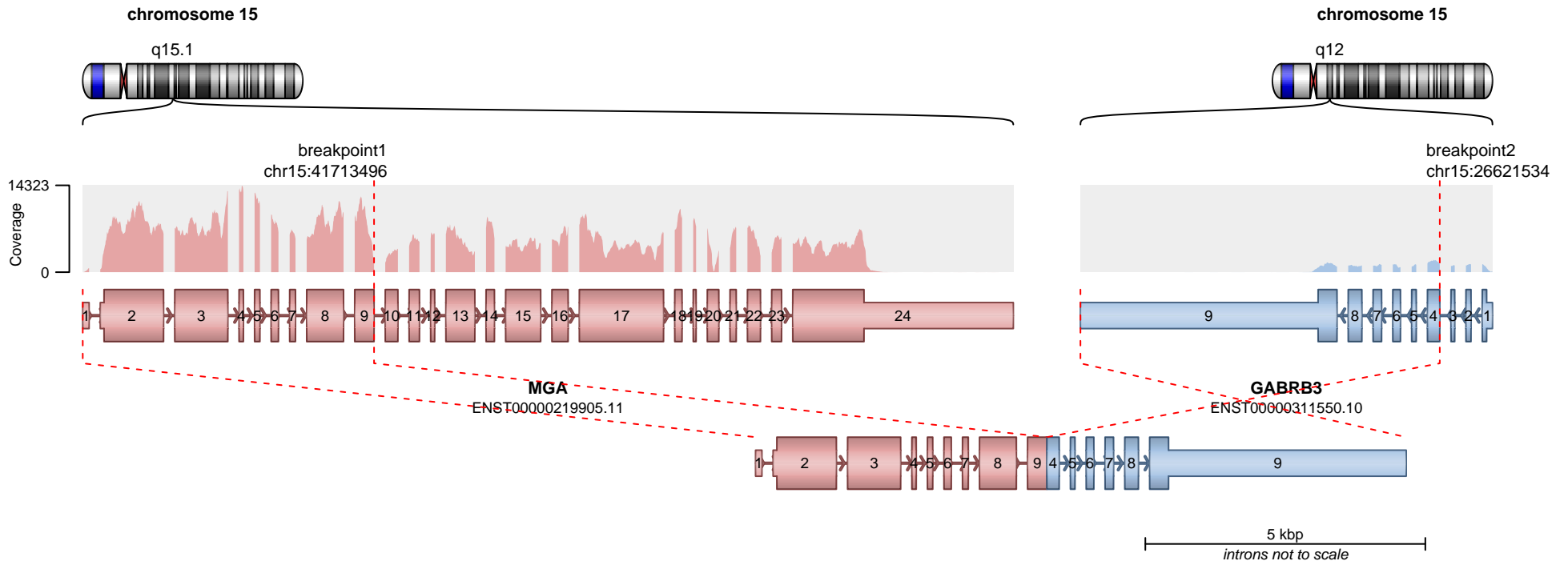

RETAINED PROTEIN DOMAINS
reading frame unclear

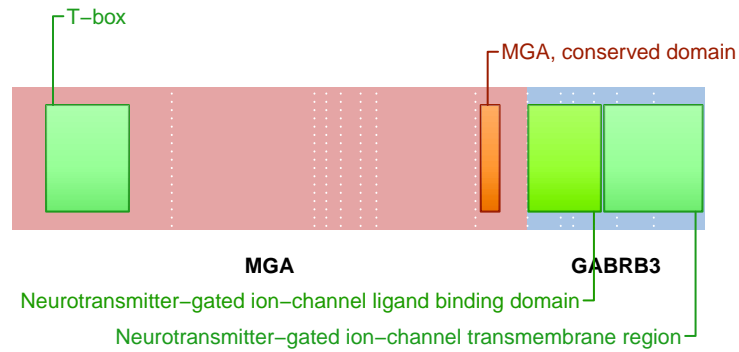

SUPPORTING READ COUNT

Split reads = 87
Discordant mates = 6

— translocation — deletion
— duplication — inversion

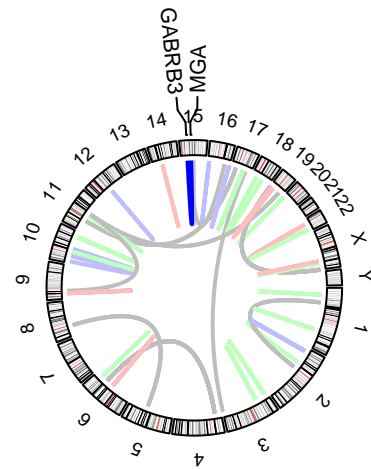
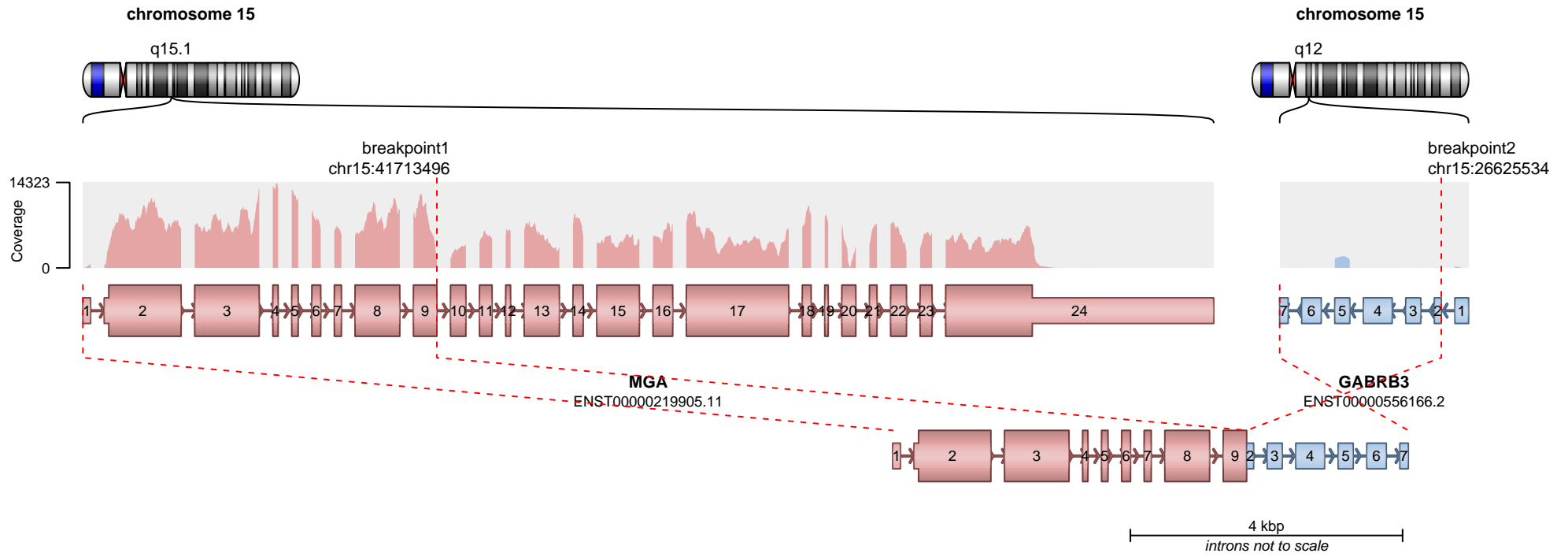

RETAINED PROTEIN DOMAINS
reading frame unclear

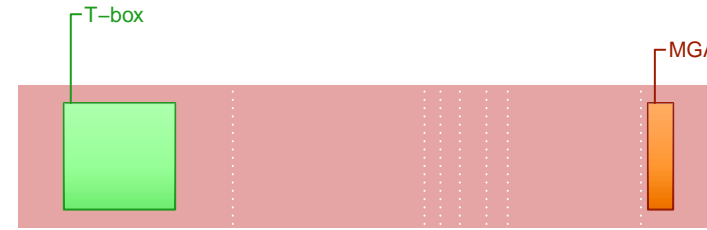

SUPPORTING READ COUNT

Split reads = 10
Discordant mates = 6

- translocation
- duplication
- deletion
- inversion

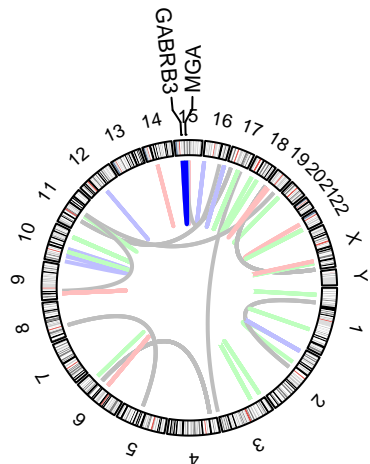
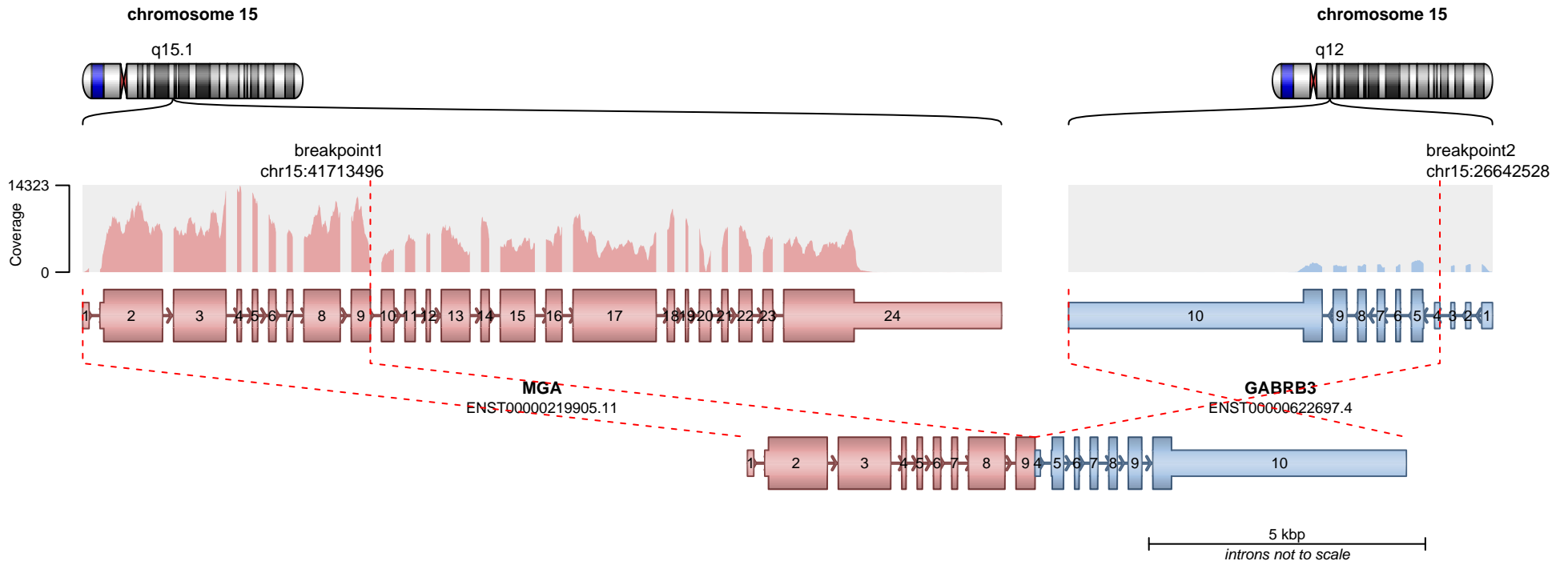

RETAINED PROTEIN DOMAINS
reading frame unclear

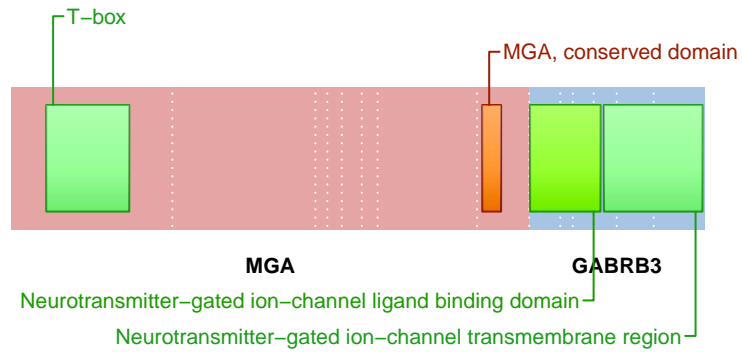

SUPPORTING READ COUNT

Split reads = 6
Discordant mates = 11

— translocation — deletion
— duplication — inversion

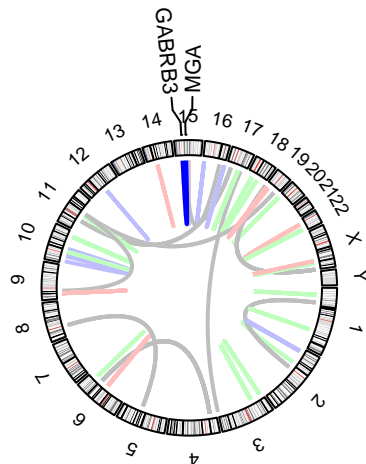
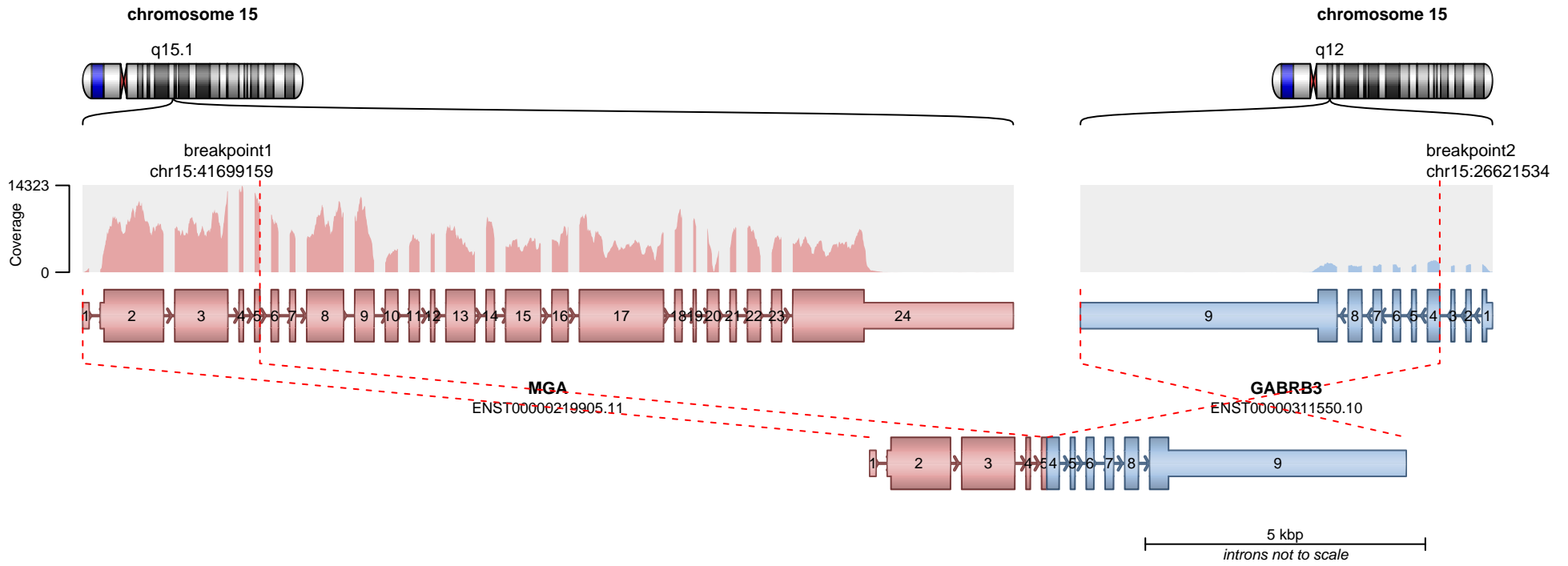

RETAINED PROTEIN DOMAINS
reading frame unclear

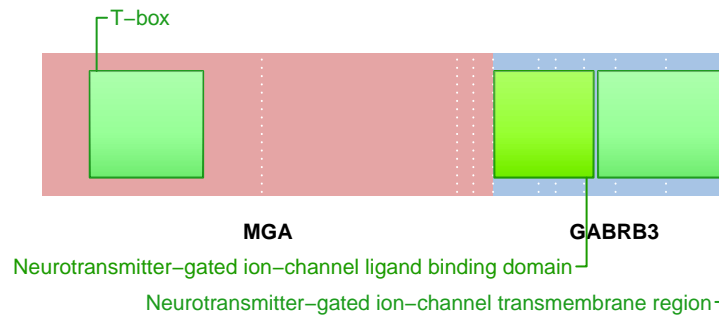

SUPPORTING READ COUNT

Split reads = 1
Discordant mates = 0

— translocation — deletion
— duplication — inversion

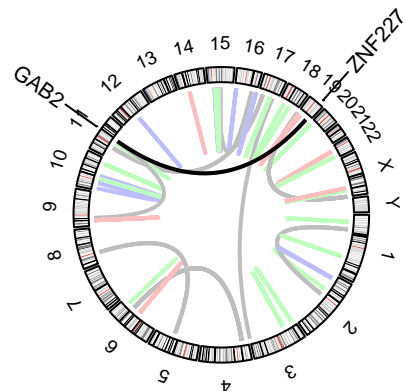
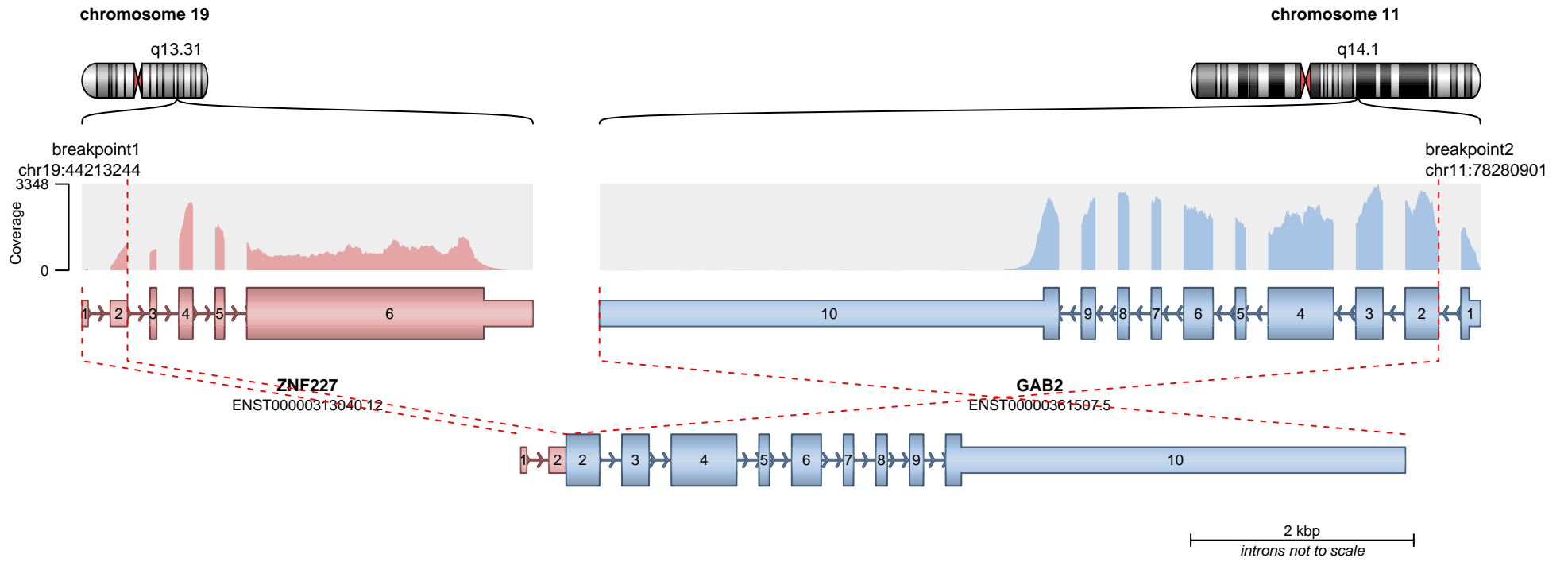

RETAINED PROTEIN DOMAINS
reading frame unclear

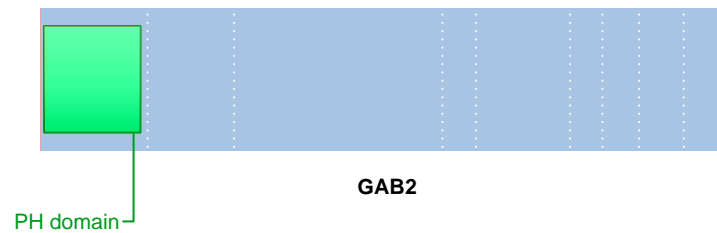

SUPPORTING READ COUNT

Split reads = 80
Discordant mates = 13

— translocation — deletion
— duplication — inversion

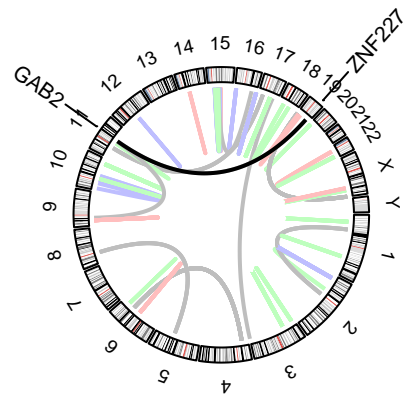
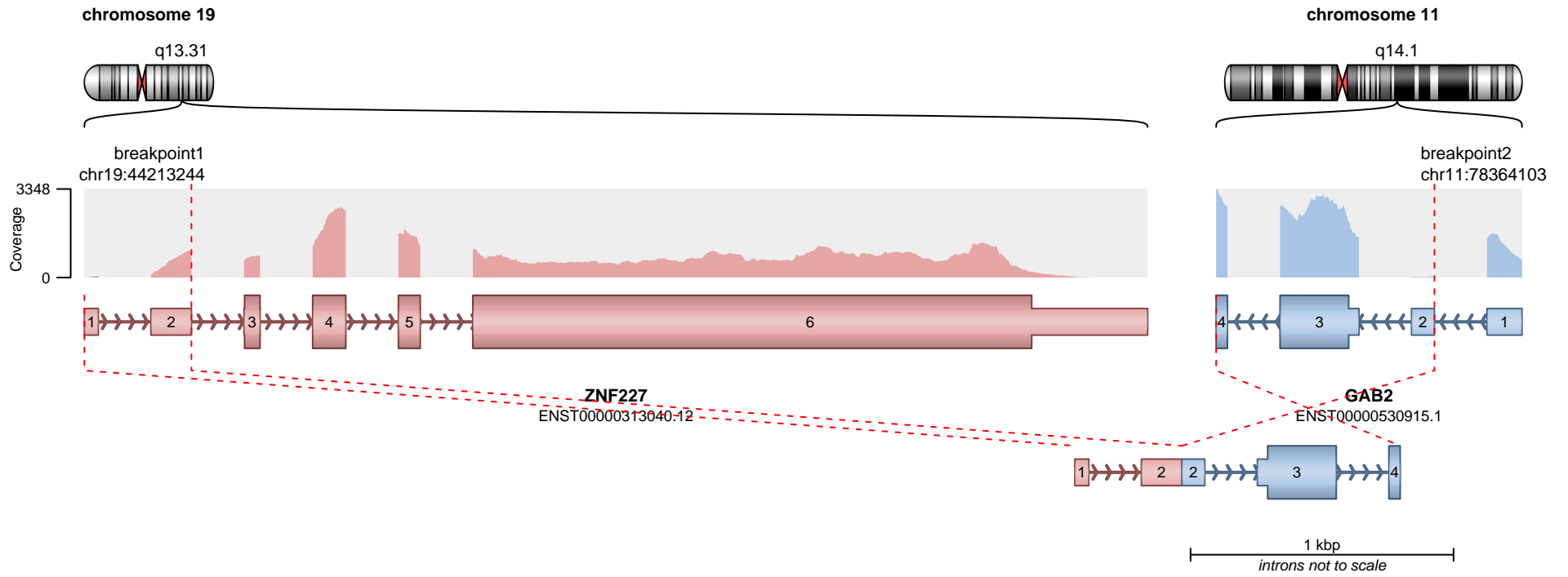

RETAINED PROTEIN DOMAINS
reading frame unclear

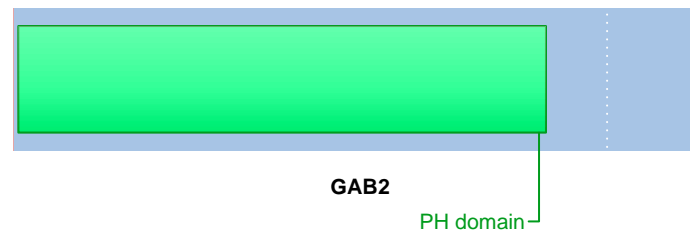

SUPPORTING READ COUNT

Split reads = 1
Discordant mates = 13

— translocation — deletion
— duplication — inversion

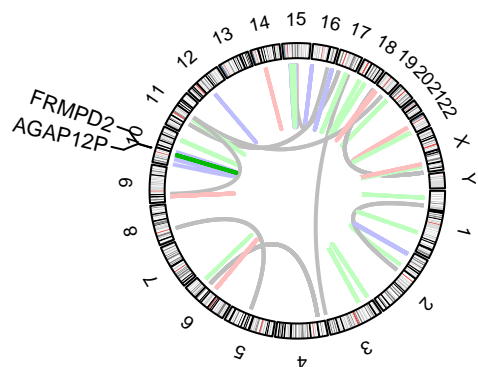
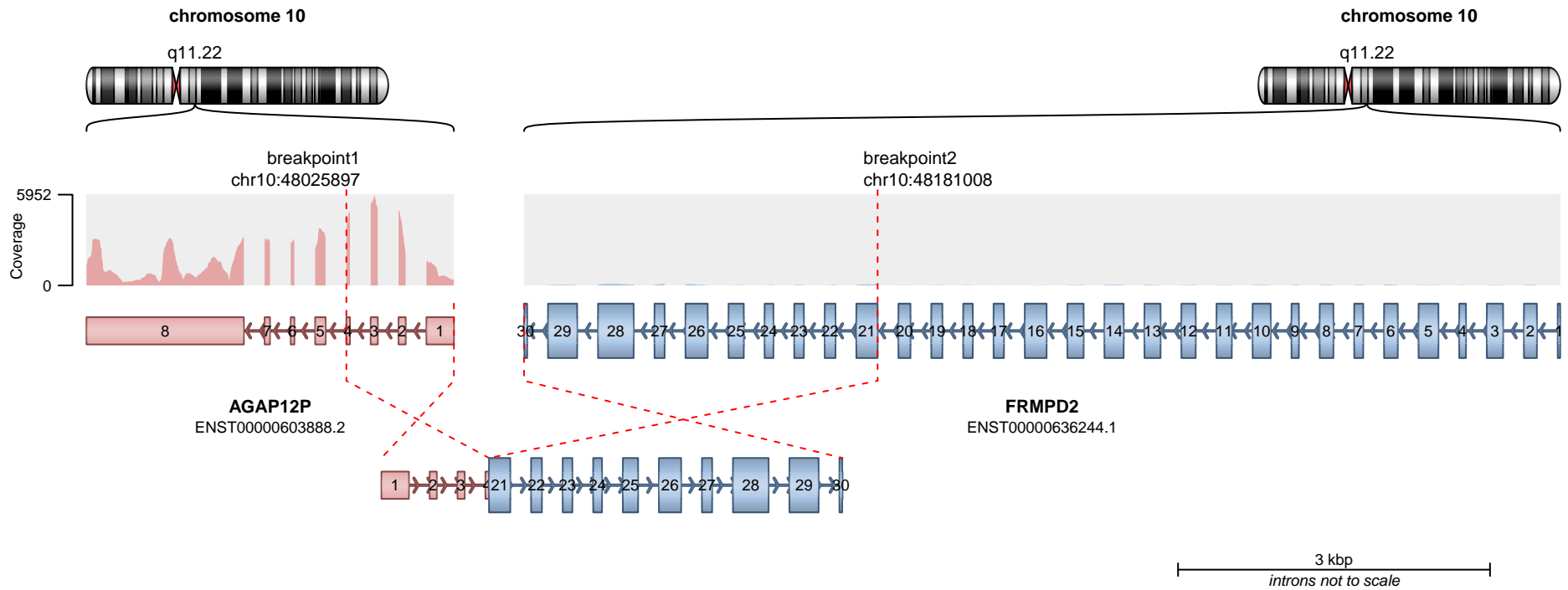

RETAINED PROTEIN DOMAINS
reading frame unclear

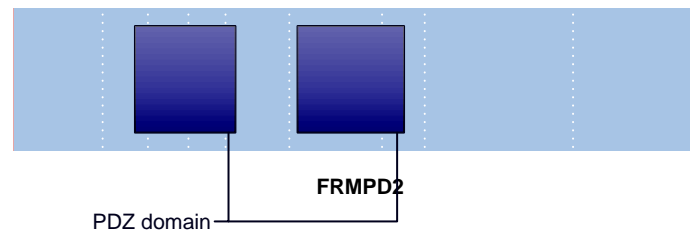

SUPPORTING READ COUNT

Split reads = 70
Discordant mates = 1

— translocation — deletion
— duplication — inversion

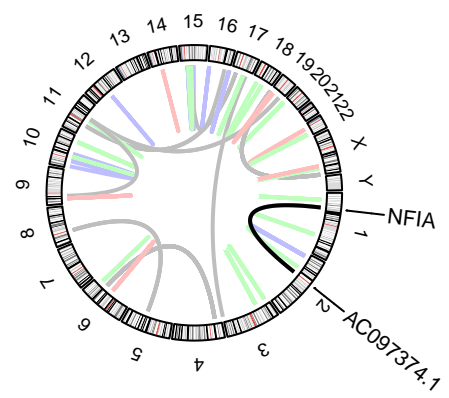
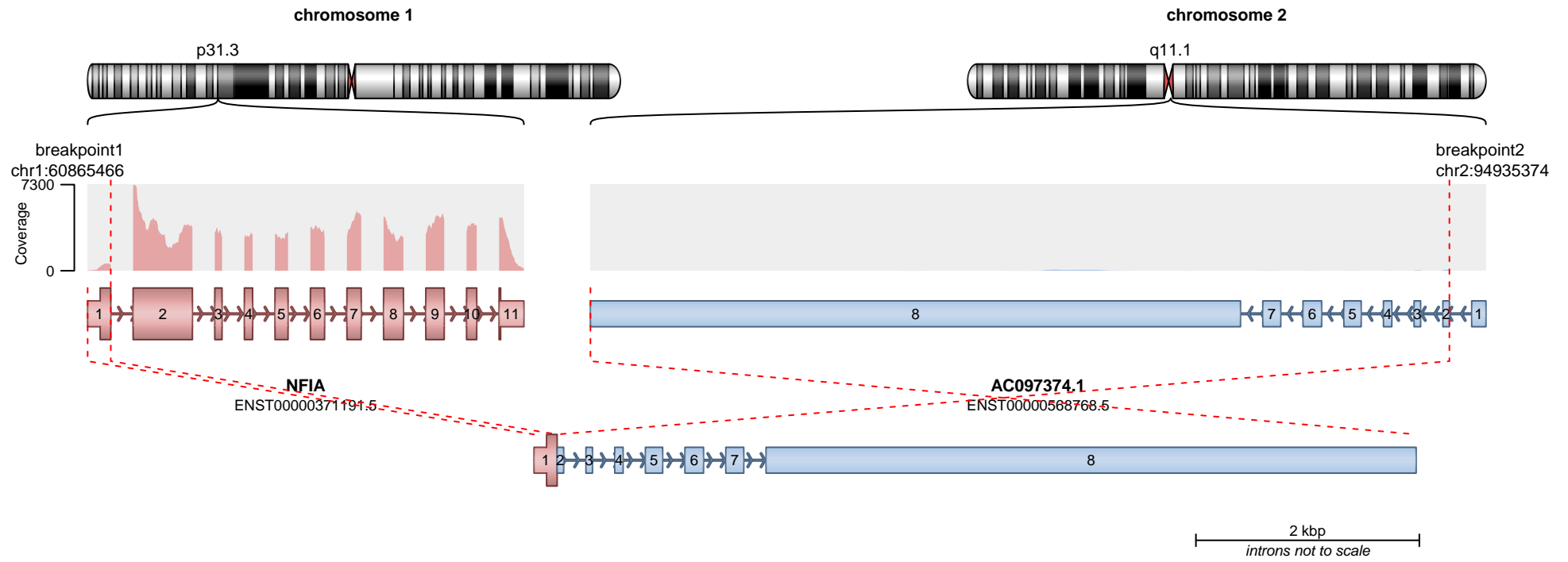

— translocation — deletion
— duplication — inversion

No protein domains retained in fusion.

SUPPORTING READ COUNT

Split reads = 61
Discordant mates = 1

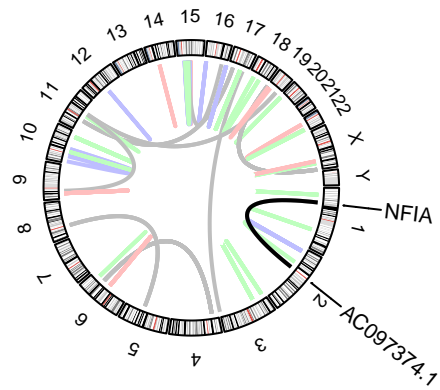
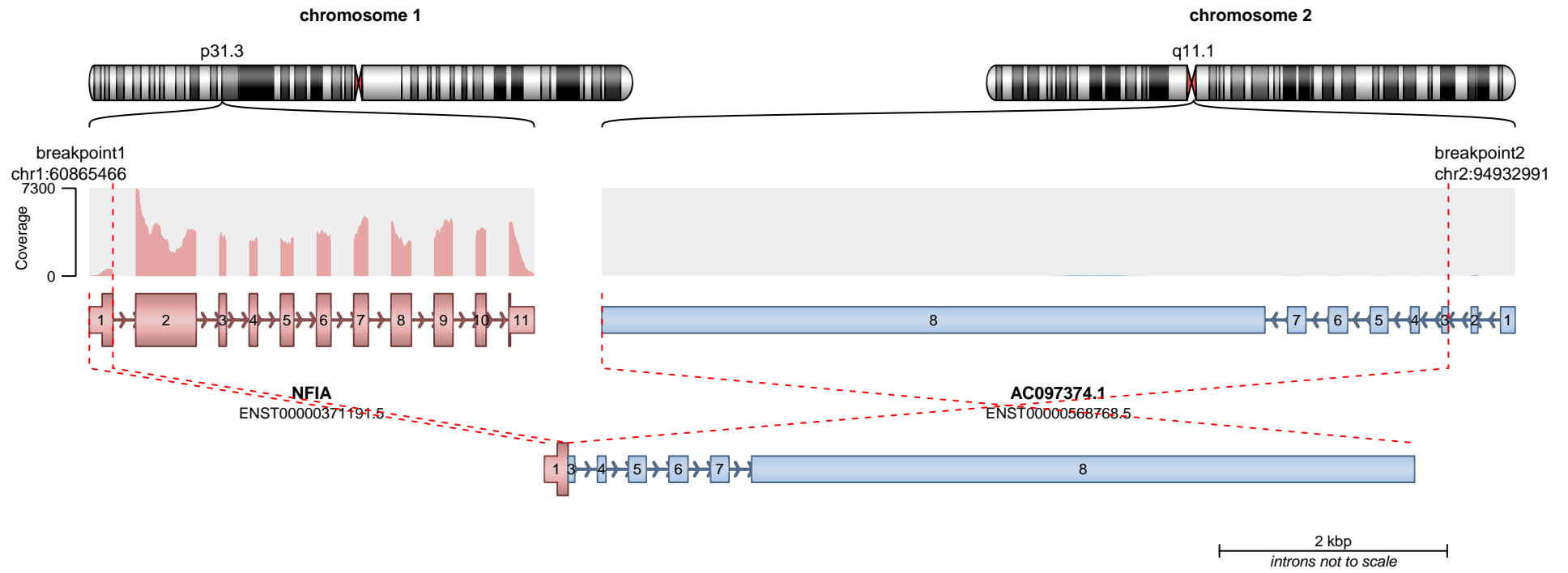

— translocation — deletion
— duplication — inversion

No protein domains retained in fusion.

SUPPORTING READ COUNT

Split reads = 4
Discordant mates = 0

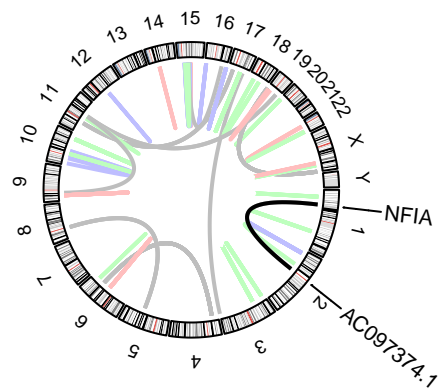
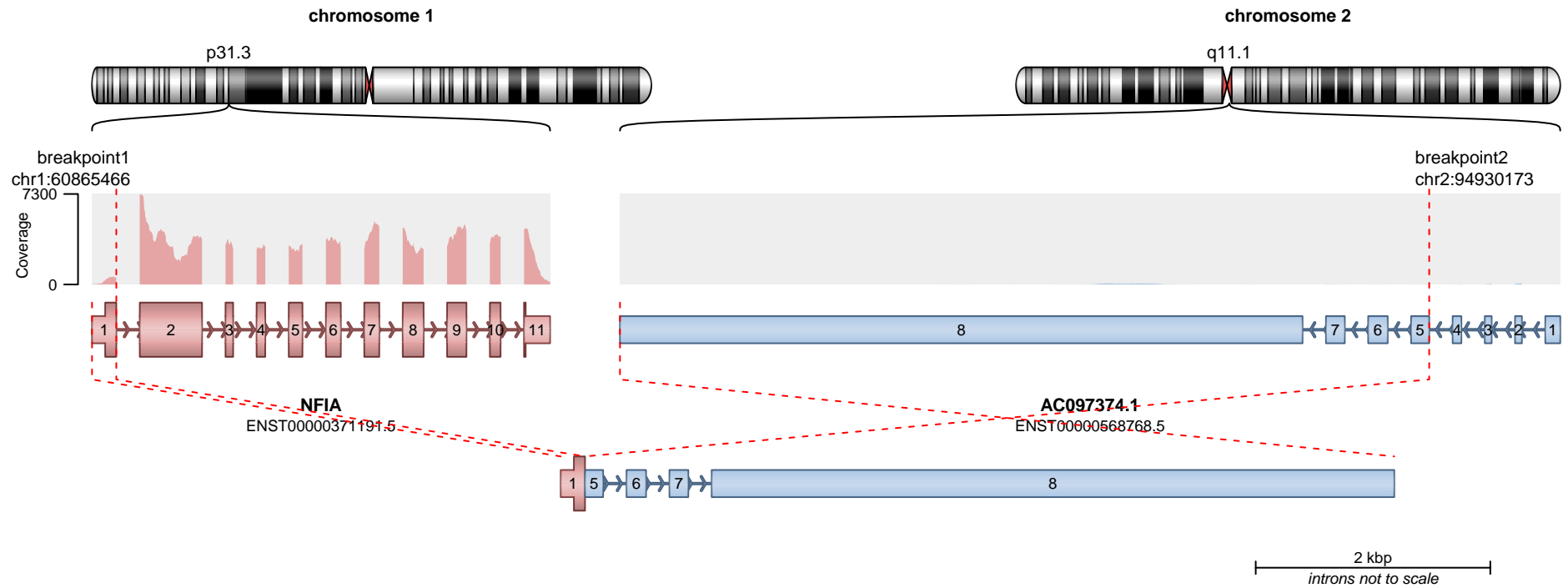

— translocation — deletion
— duplication — inversion

No protein domains retained in fusion.

SUPPORTING READ COUNT

Split reads = 1
Discordant mates = 0

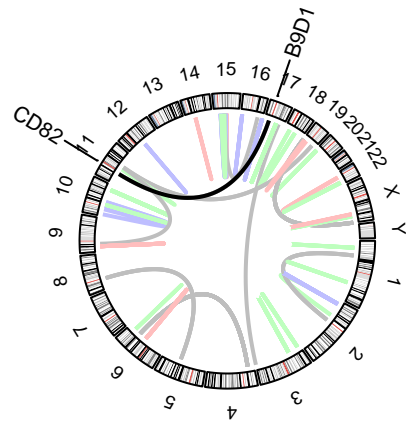
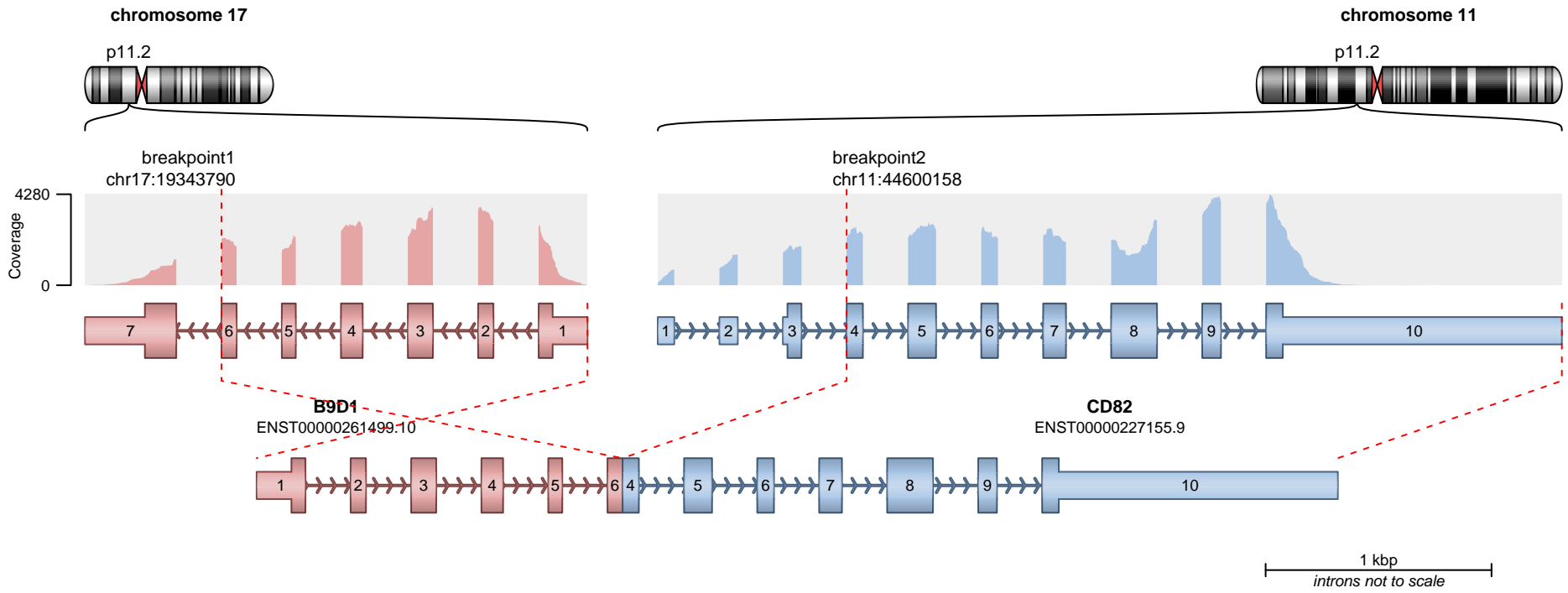

RETAINED PROTEIN DOMAINS
reading frame unclear

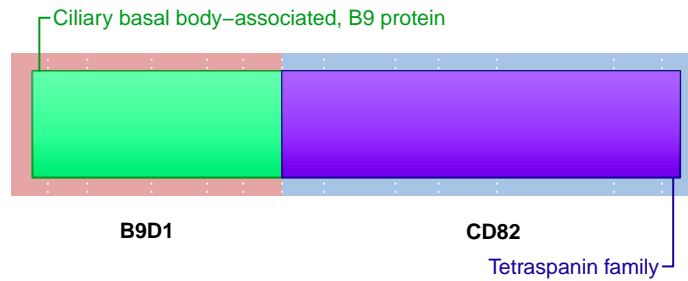

SUPPORTING READ COUNT

Split reads = 56
Discordant mates = 3

— translocation — deletion
— duplication — inversion

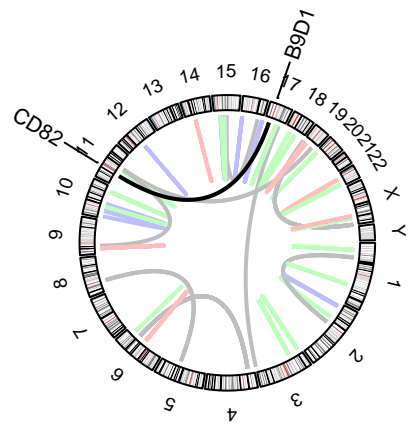
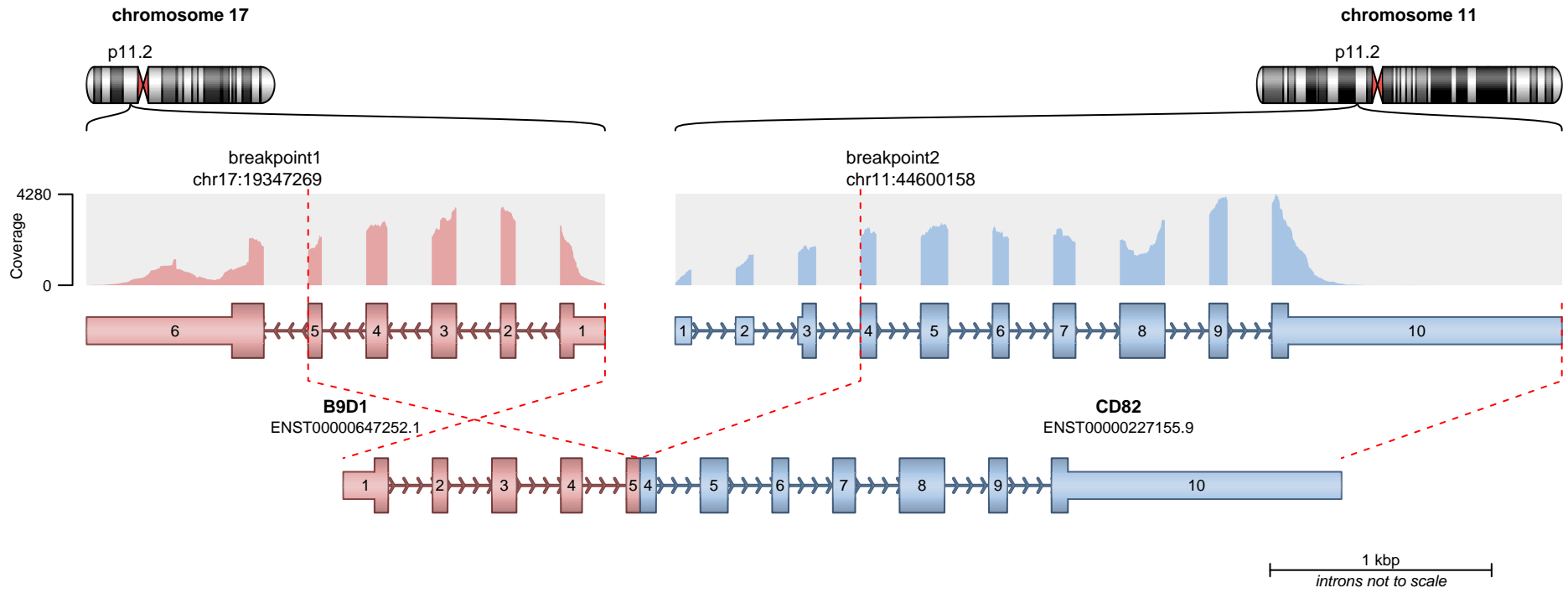

RETAINED PROTEIN DOMAINS
reading frame unclear

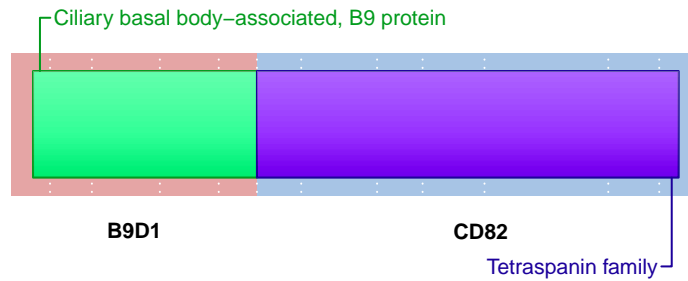

SUPPORTING READ COUNT

Split reads = 11
Discordant mates = 1

- translocation
- duplication
- deletion
- inversion

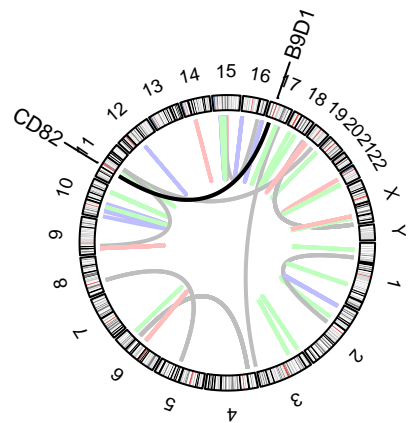
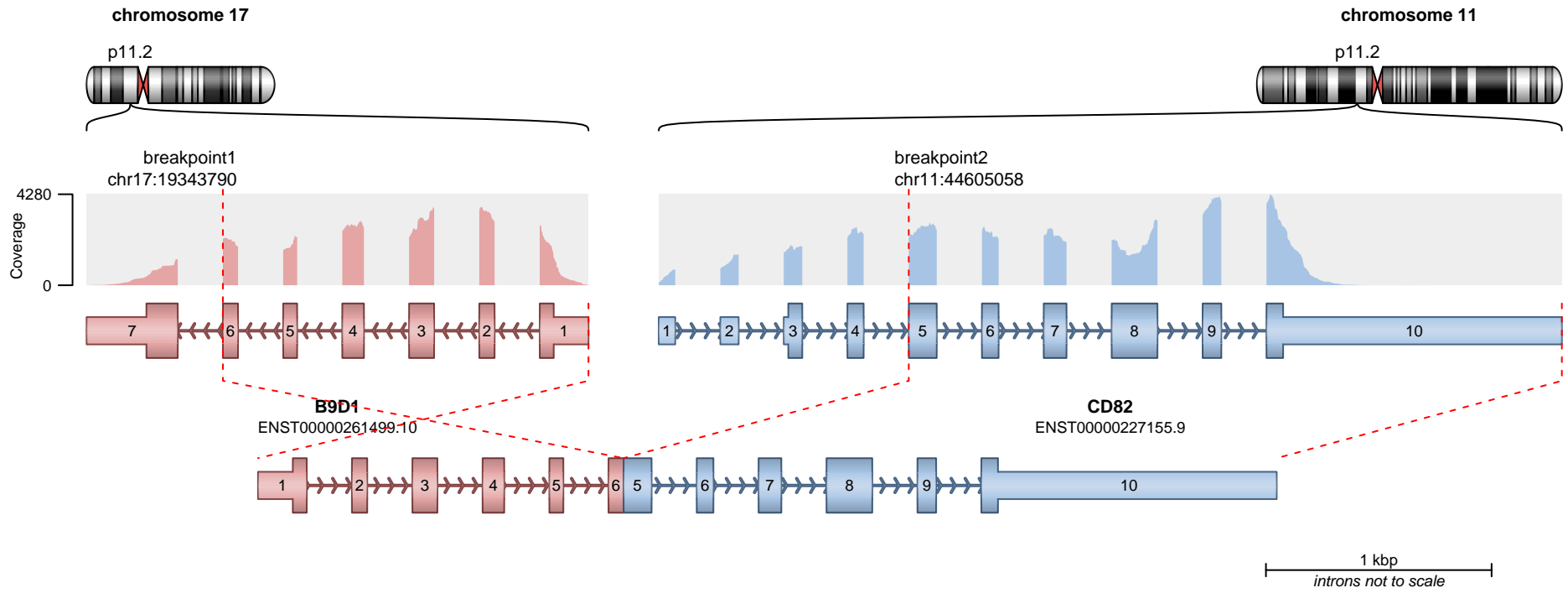

RETAINED PROTEIN DOMAINS
reading frame unclear

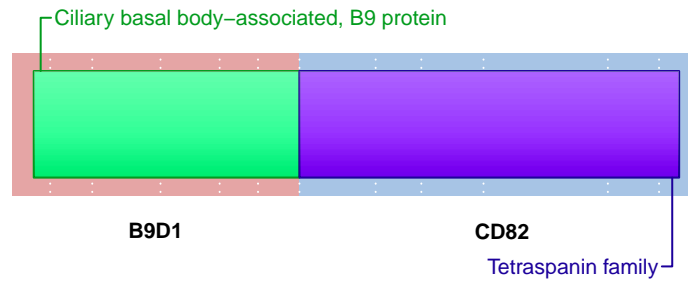

SUPPORTING READ COUNT

Split reads = 2
Discordant mates = 1

— translocation — deletion
— duplication — inversion

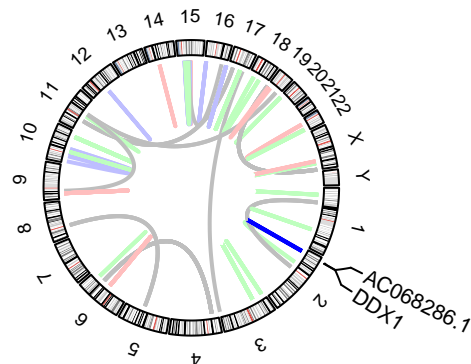
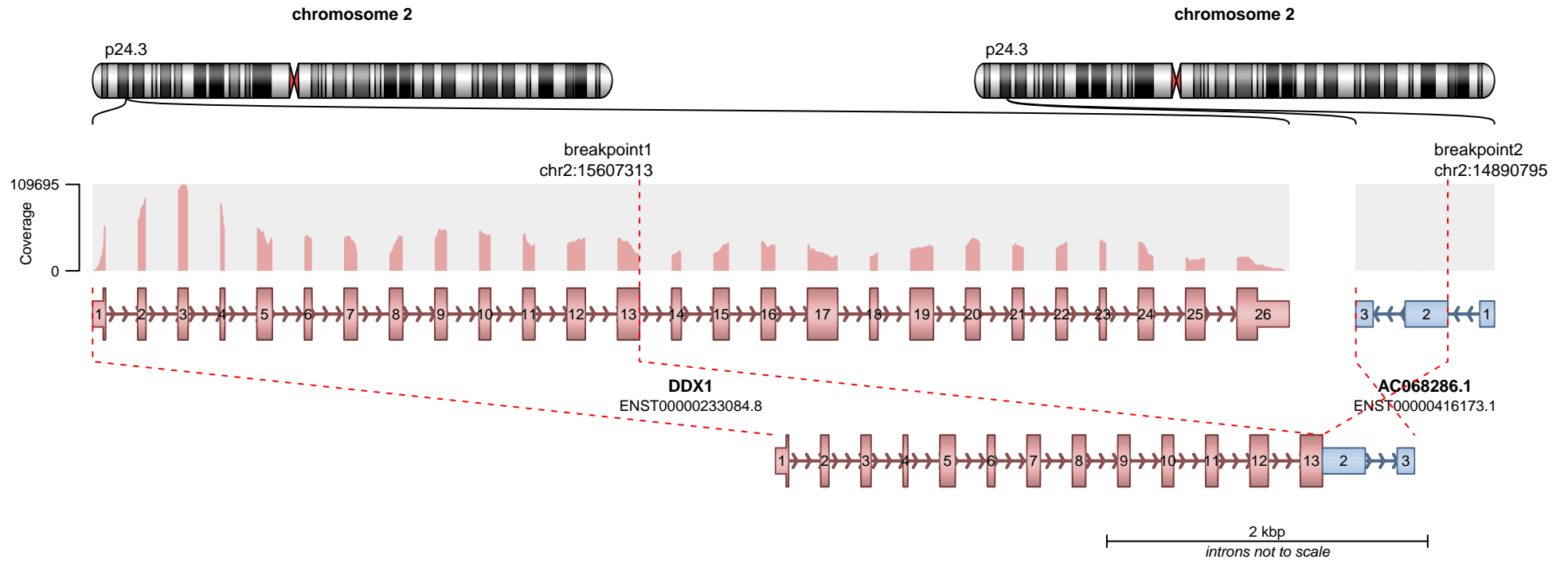

RETAINED PROTEIN DOMAINS
reading frame unclear

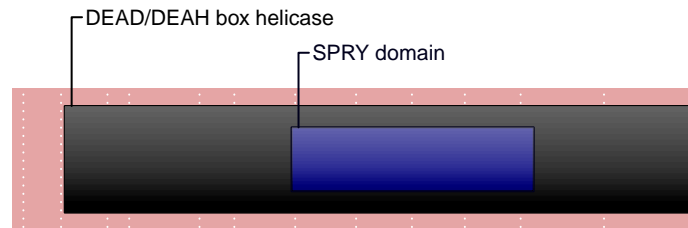

SUPPORTING READ COUNT

Split reads = 55
Discordant mates = 7

- translocation
- duplication
- deletion
- inversion

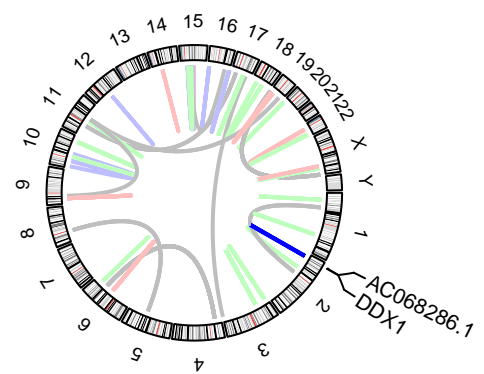
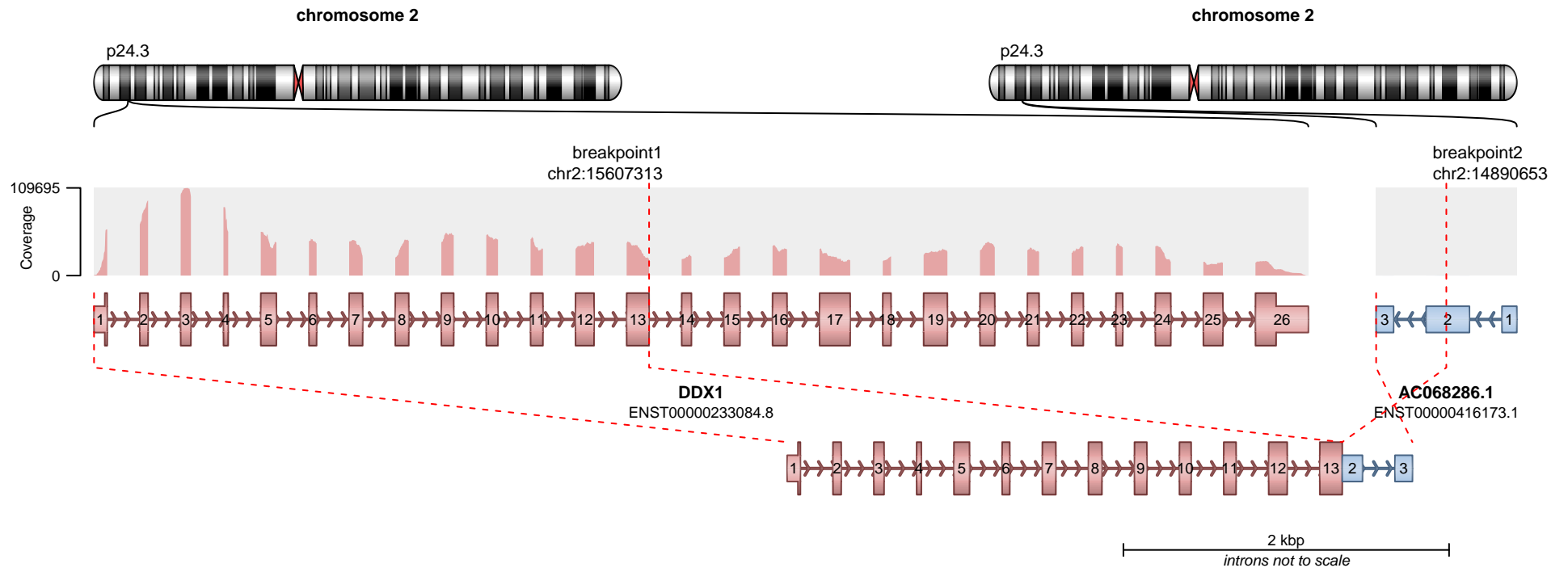

RETAINED PROTEIN DOMAINS
reading frame unclear

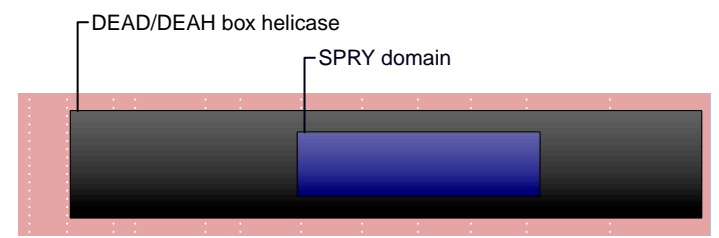

DDX1

SUPPORTING READ COUNT

Split reads = 48
Discordant mates = 3

- translocation
- duplication
- deletion
- inversion

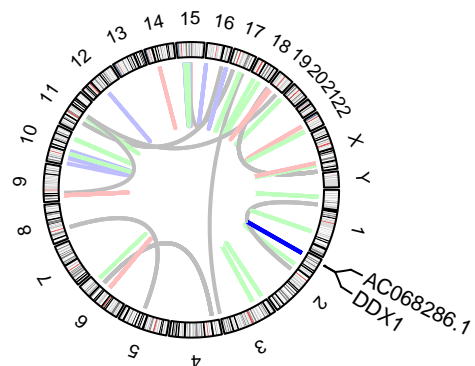
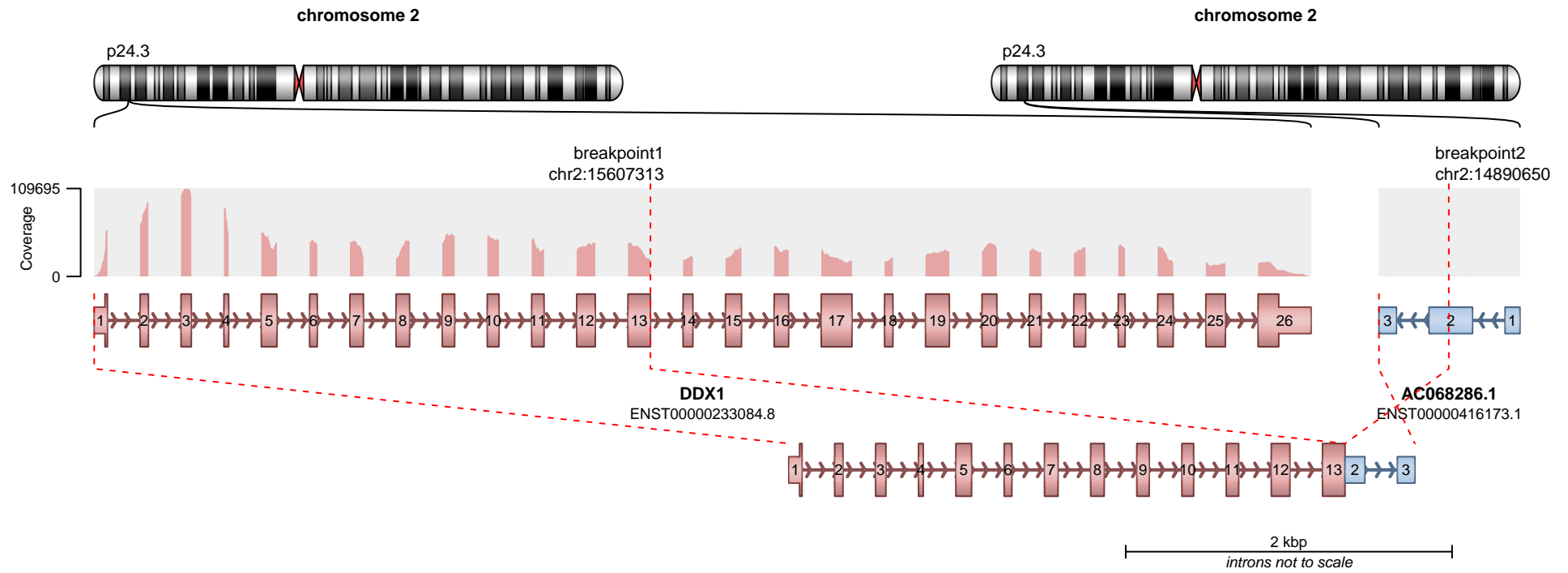

RETAINED PROTEIN DOMAINS
reading frame unclear

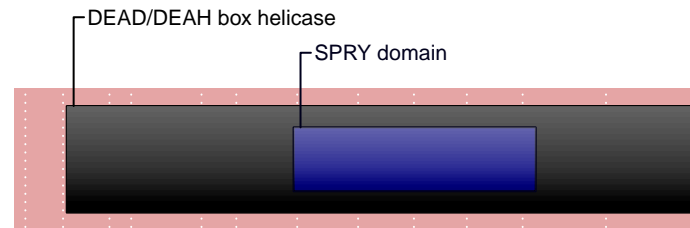

SUPPORTING READ COUNT

Split reads = 30
Discordant mates = 3

— translocation — deletion
— duplication — inversion

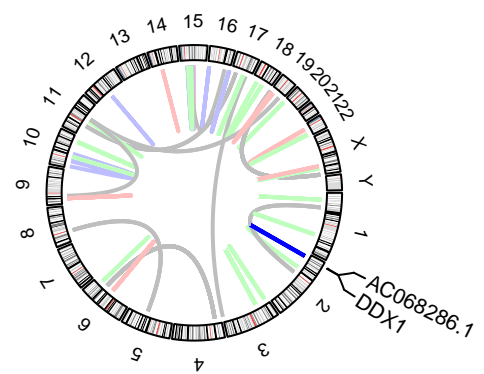
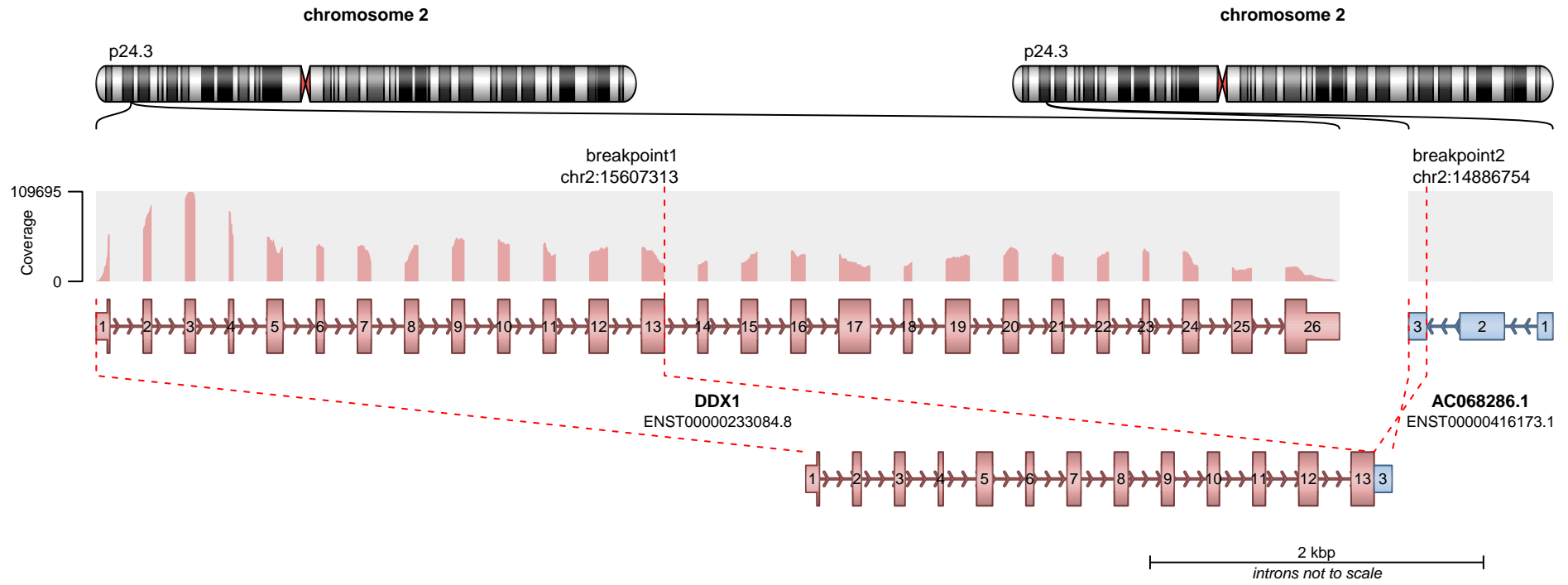

RETAINED PROTEIN DOMAINS
reading frame unclear

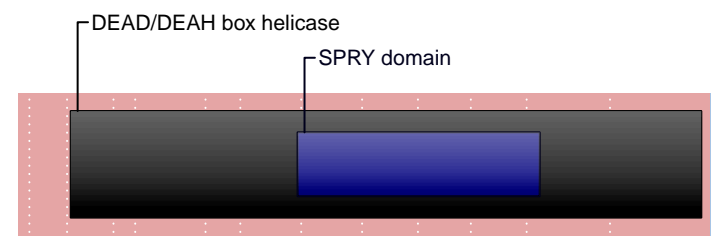

SUPPORTING READ COUNT

Split reads = 27
Discordant mates = 0

- translocation
- duplication
- deletion
- inversion

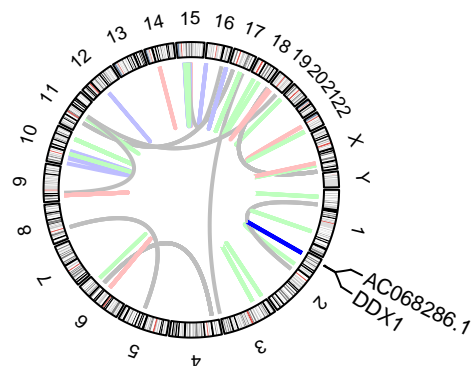
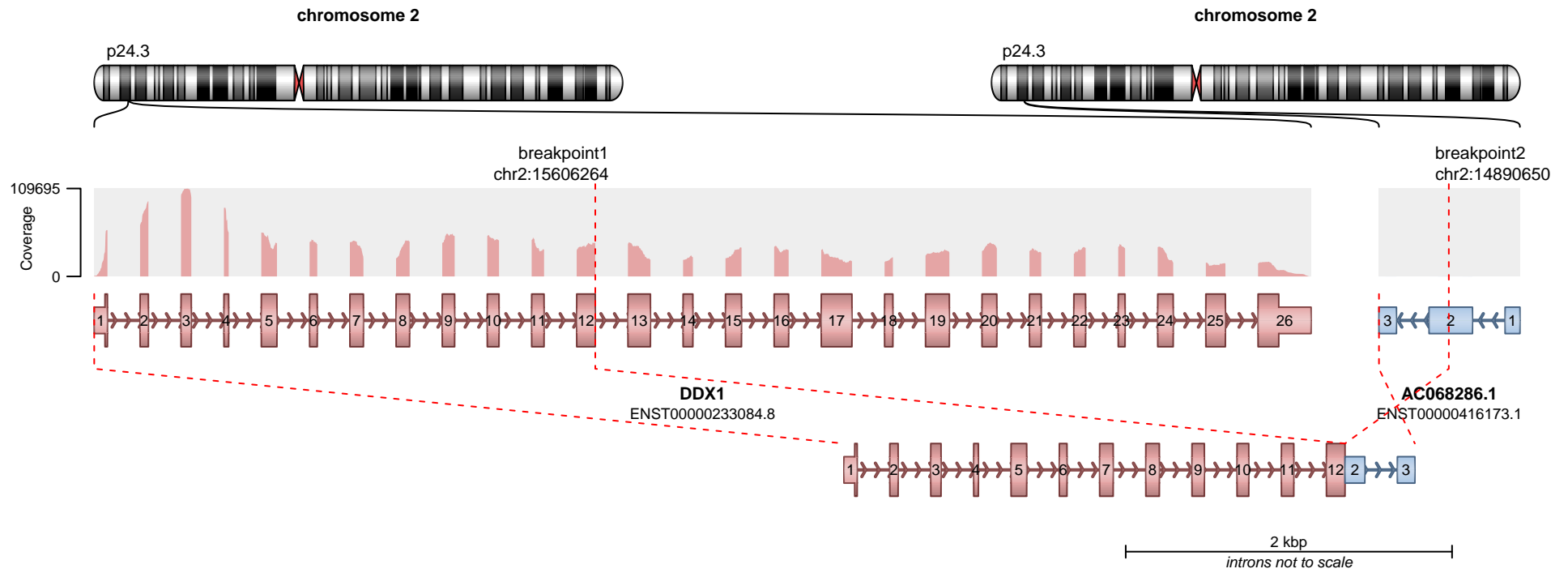

RETAINED PROTEIN DOMAINS
reading frame unclear

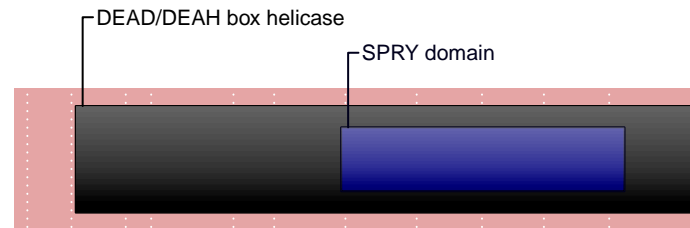

SUPPORTING READ COUNT

Split reads = 4
Discordant mates = 0

— translocation — deletion
— duplication — inversion

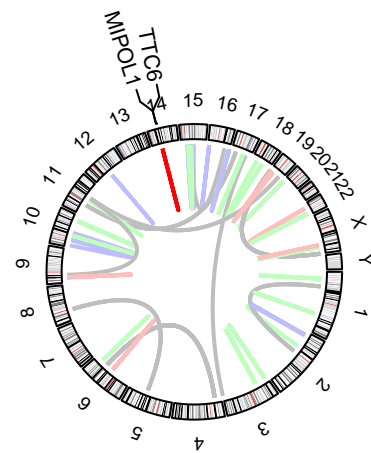
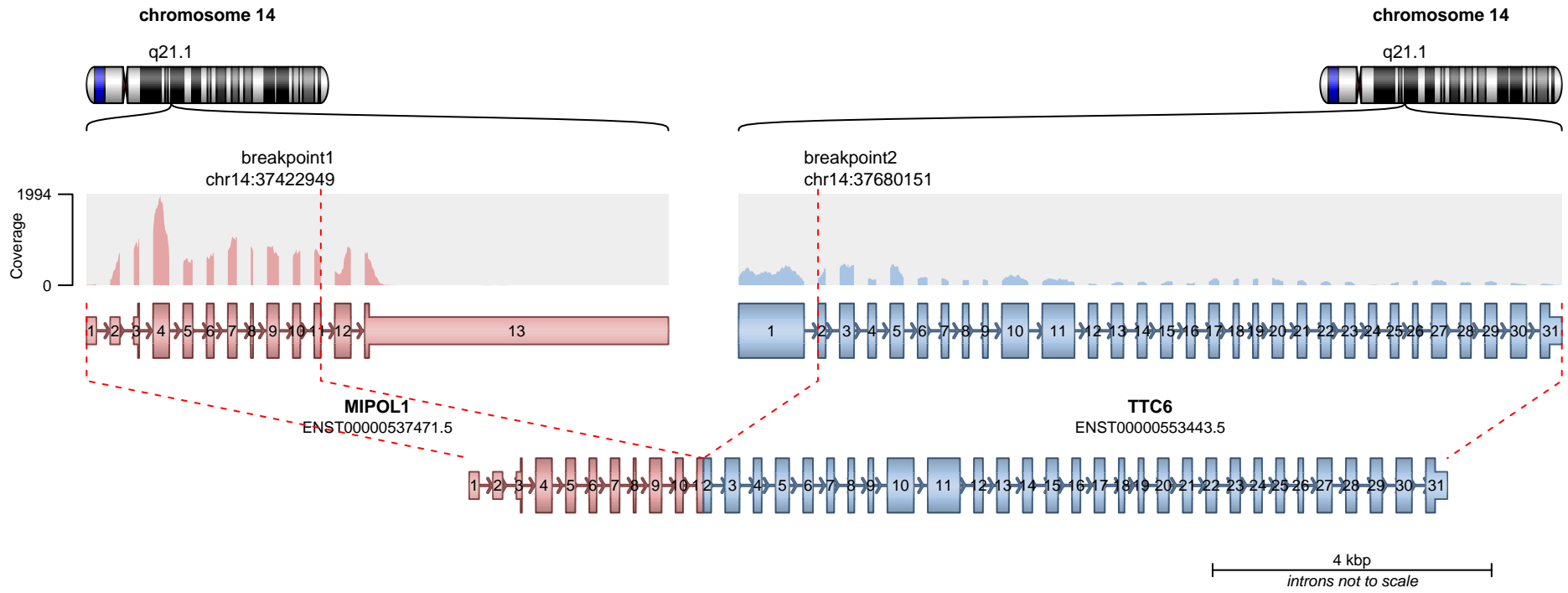

— translocation — deletion
— duplication — inversion

RETAINED PROTEIN DOMAINS
reading frame unclear

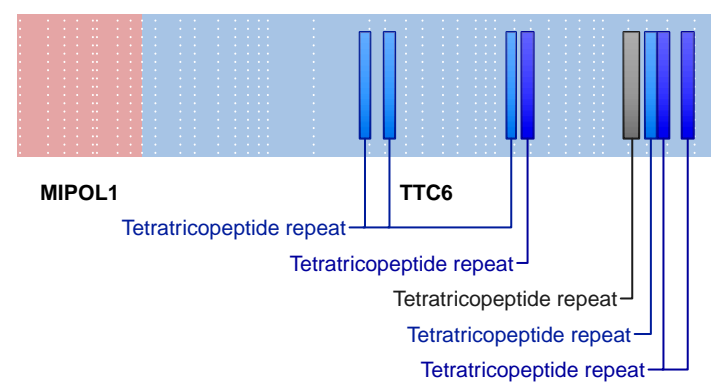

SUPPORTING READ COUNT

Split reads = 54
Discordant mates = 2

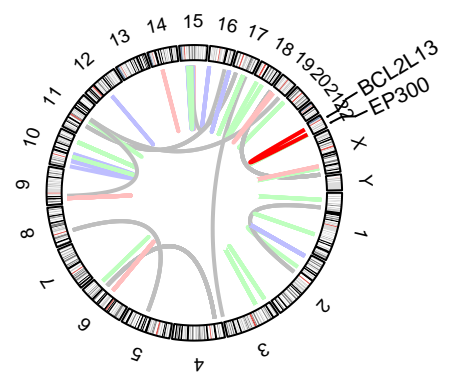
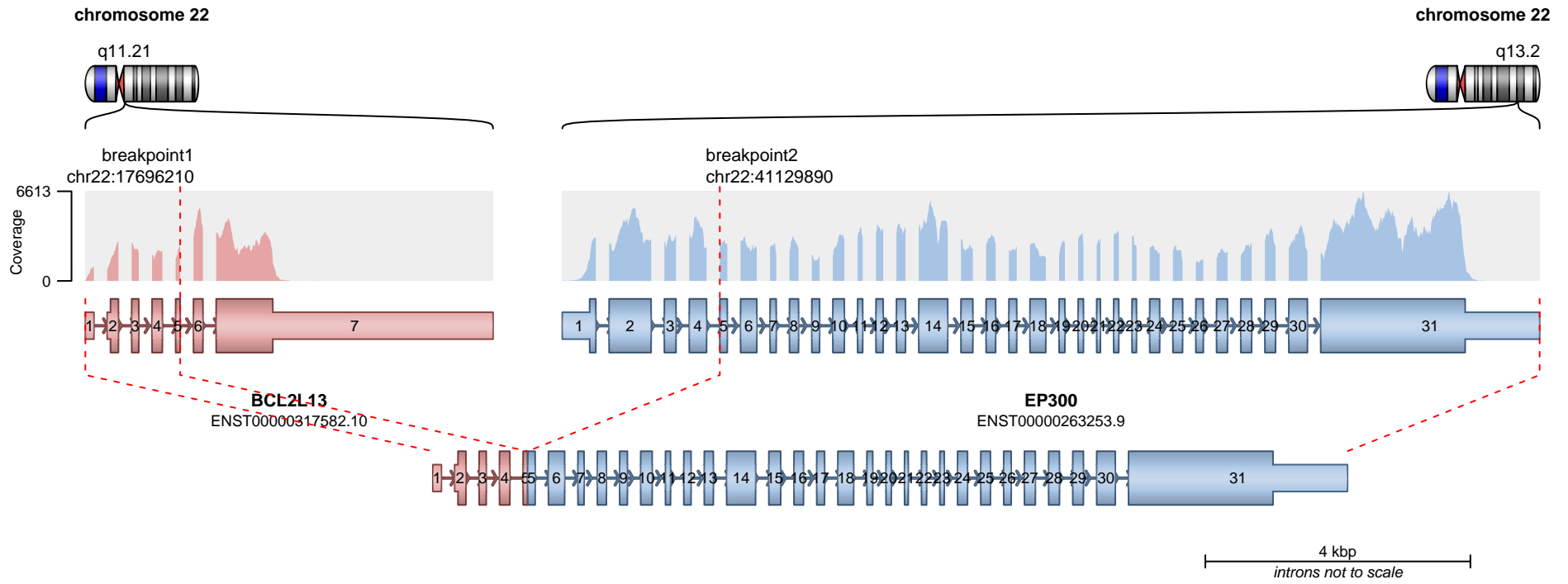

— translocation — deletion
— duplication — inversion

RETAINED PROTEIN DOMAINS
reading frame unclear

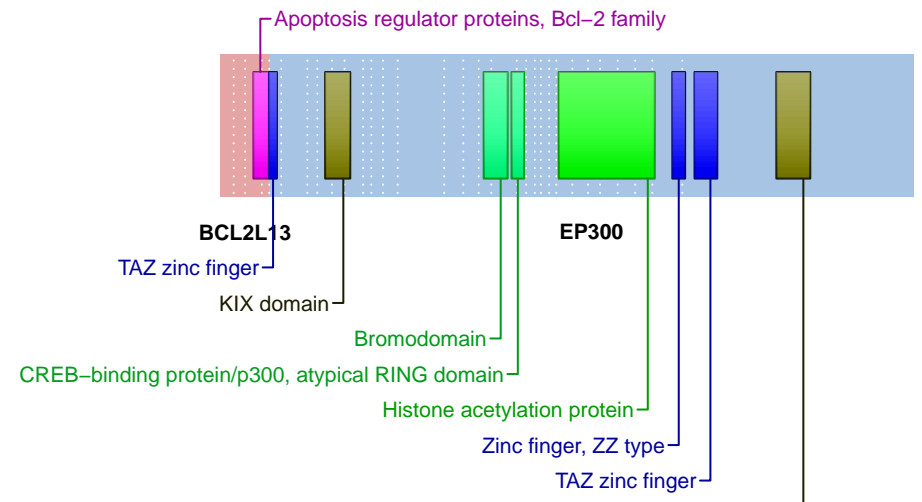

SUPPORTING READ COUNT

Split reads = 45
Discordant mates = 5

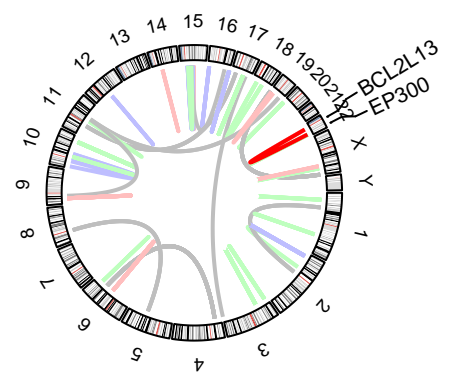
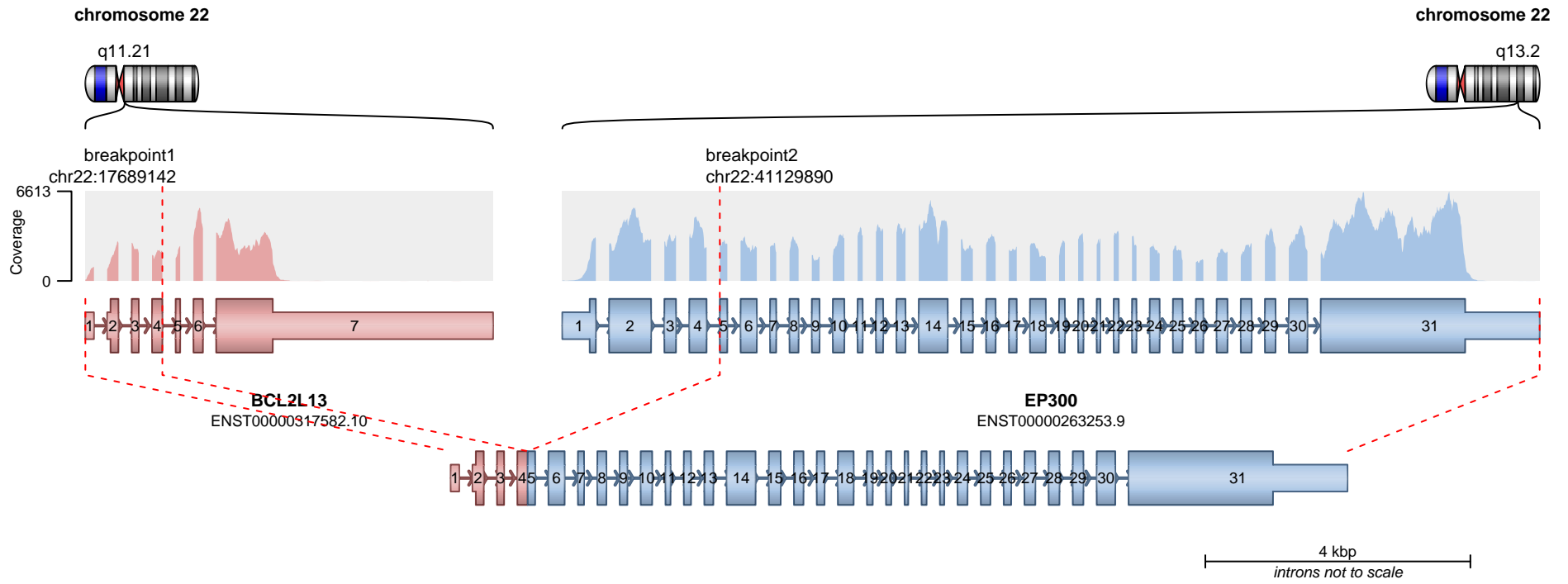

— translocation — deletion
— duplication — inversion

RETAINED PROTEIN DOMAINS
reading frame unclear

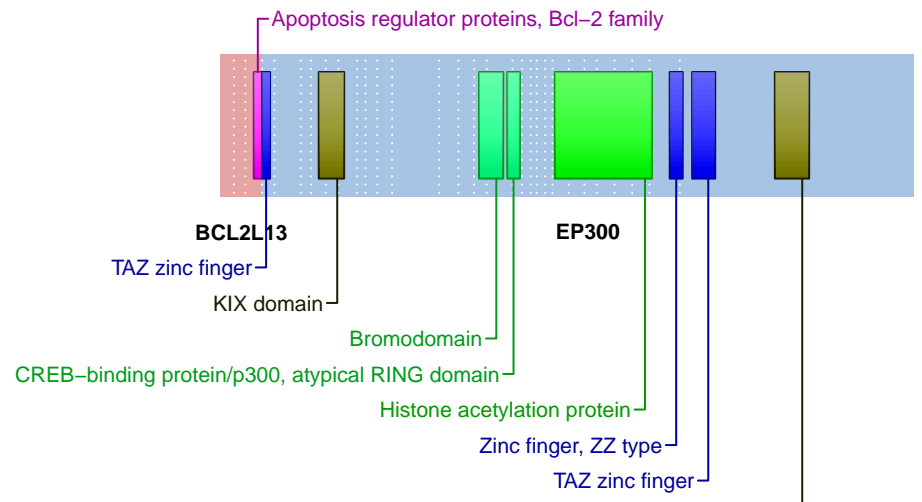

SUPPORTING READ COUNT

Split reads = 24
Discordant mates = 2

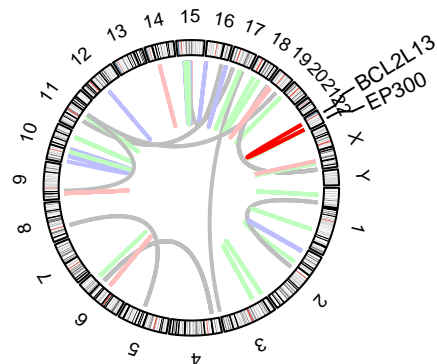
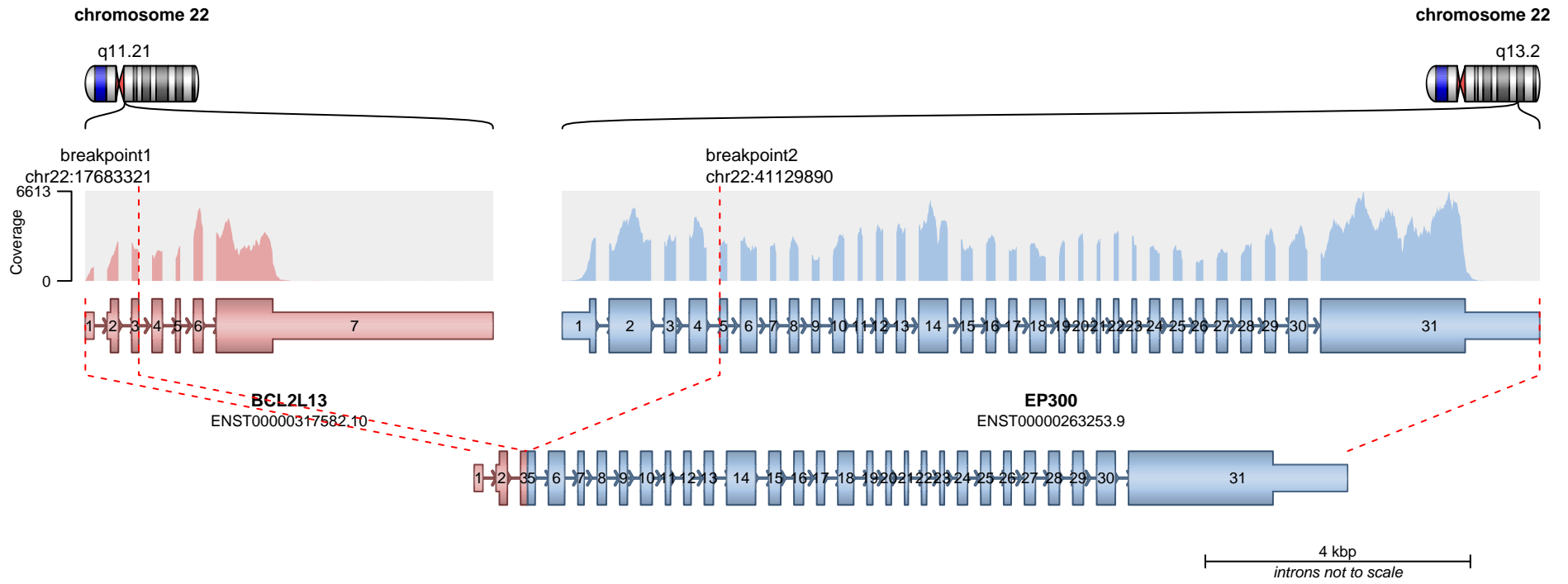

— translocation — deletion
— duplication — inversion

RETAINED PROTEIN DOMAINS
reading frame unclear

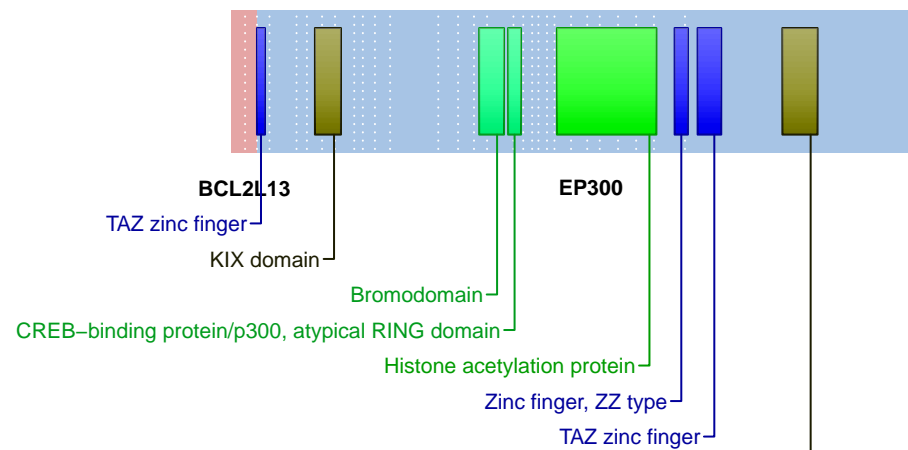

SUPPORTING READ COUNT

Split reads = 3
Discordant mates = 1

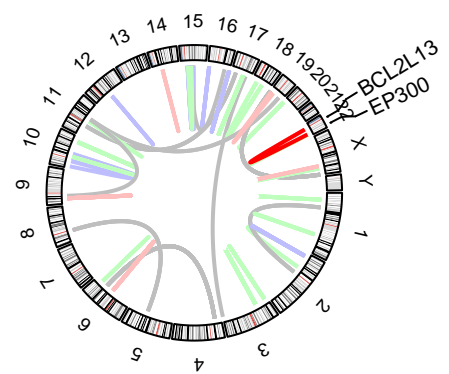
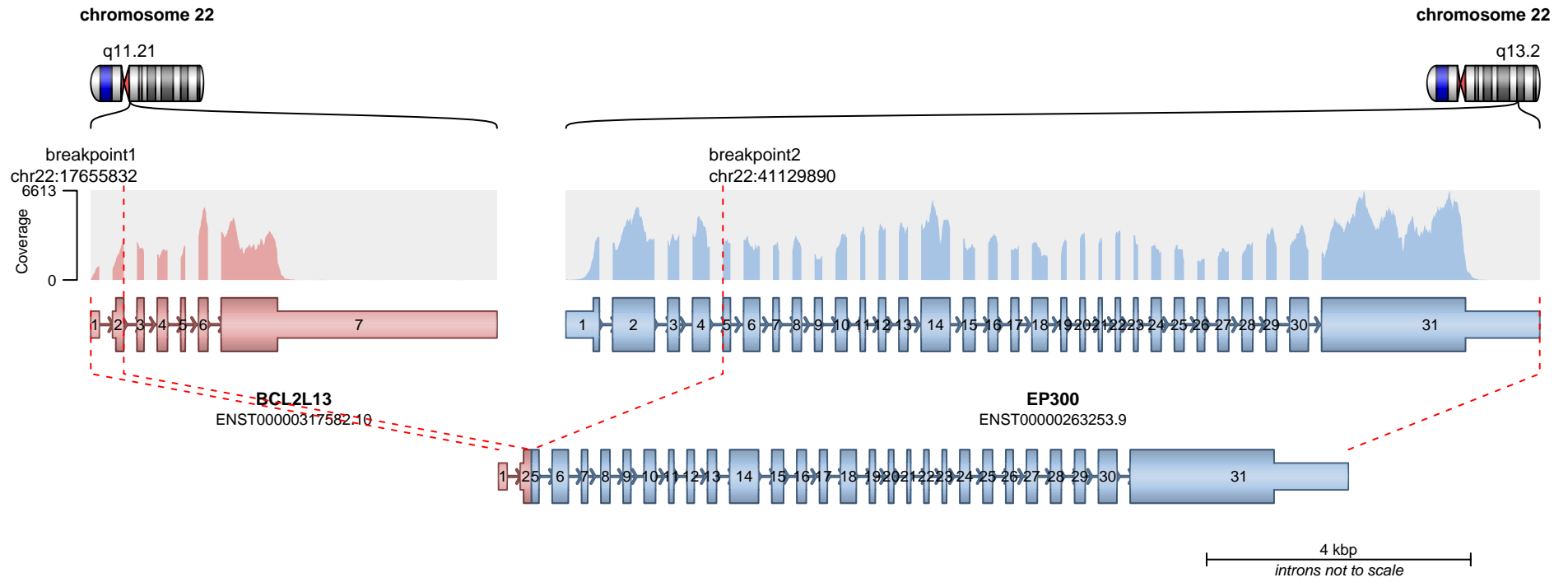

— translocation — deletion
 — duplication — inversion

RETAINED PROTEIN DOMAINS
reading frame unclear

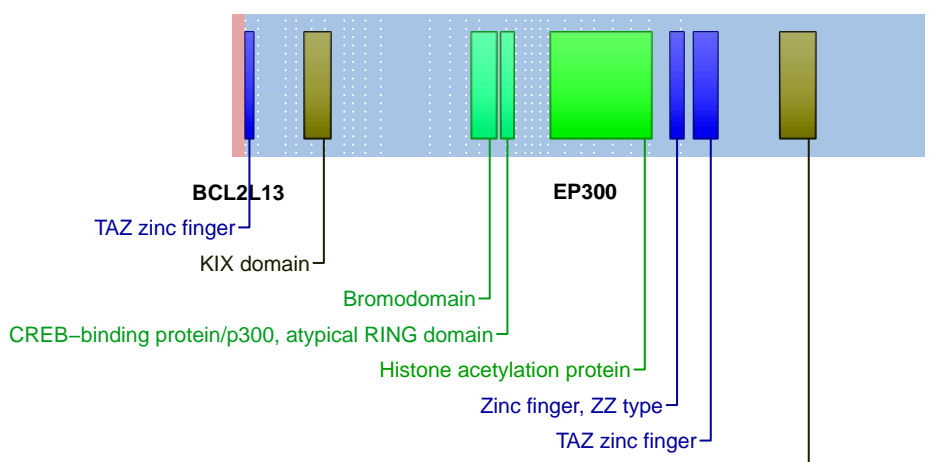

SUPPORTING READ COUNT

Split reads = 1
 Discordant mates = 0

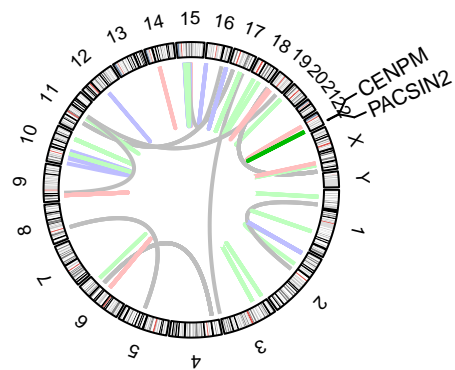
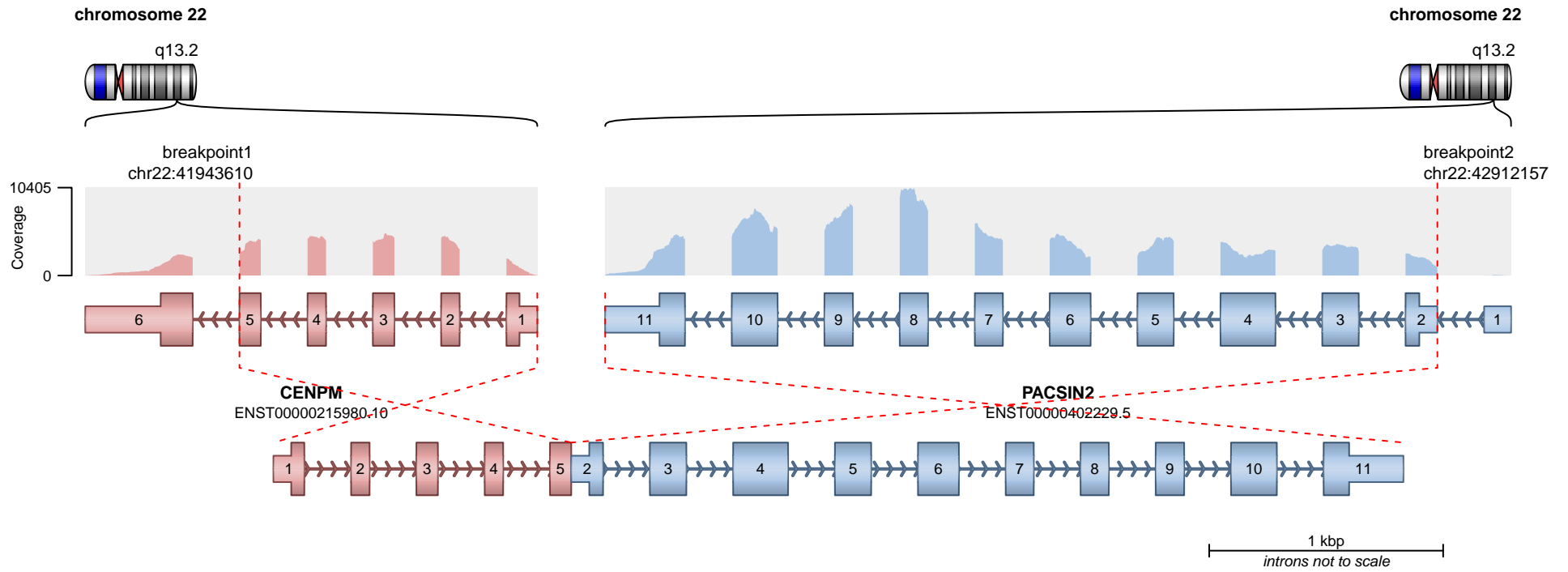

RETAINED PROTEIN DOMAINS
reading frame unclear

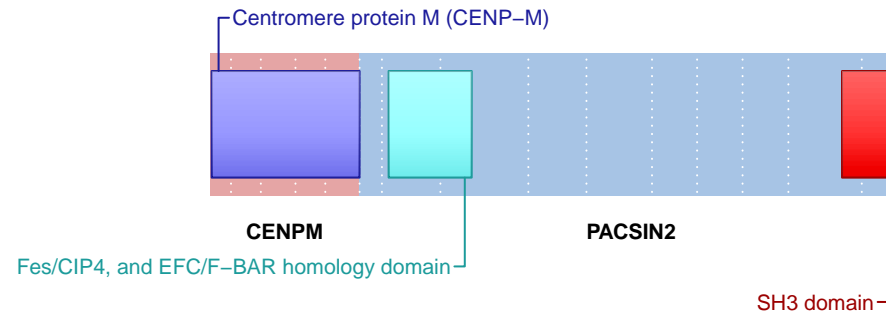

SUPPORTING READ COUNT

Split reads = 42
Discordant mates = 5

— translocation — deletion
— duplication — inversion

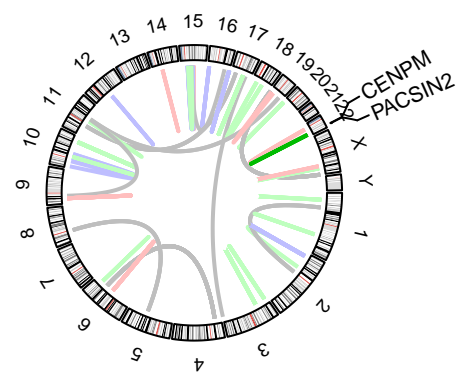
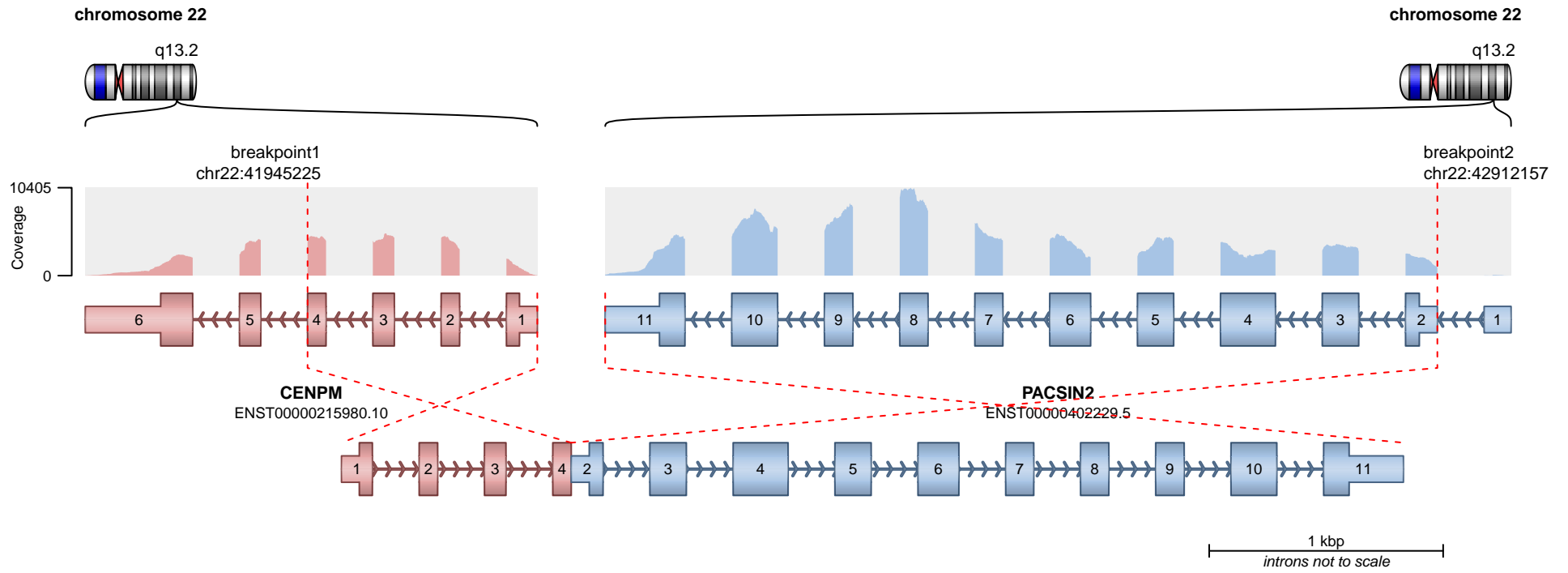

RETAINED PROTEIN DOMAINS
reading frame unclear

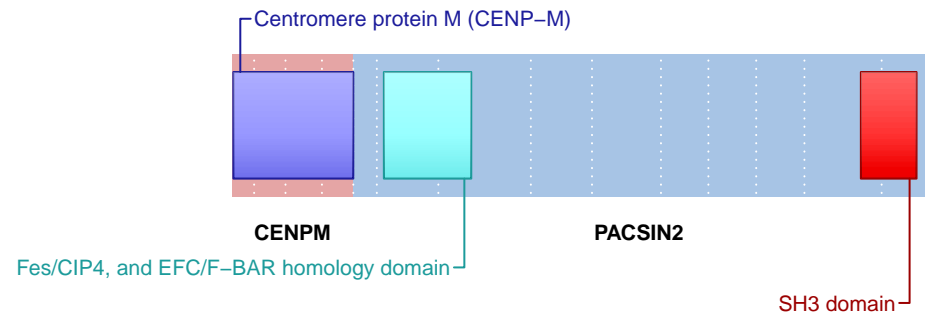

SUPPORTING READ COUNT

Split reads = 5
Discordant mates = 3

- translocation
- duplication
- deletion
- inversion

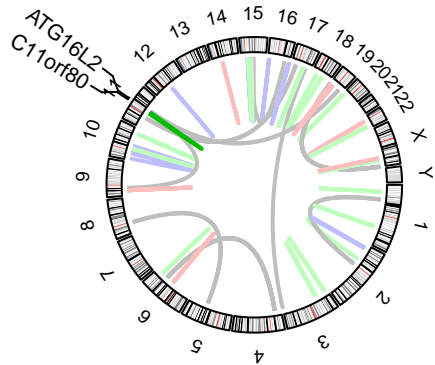
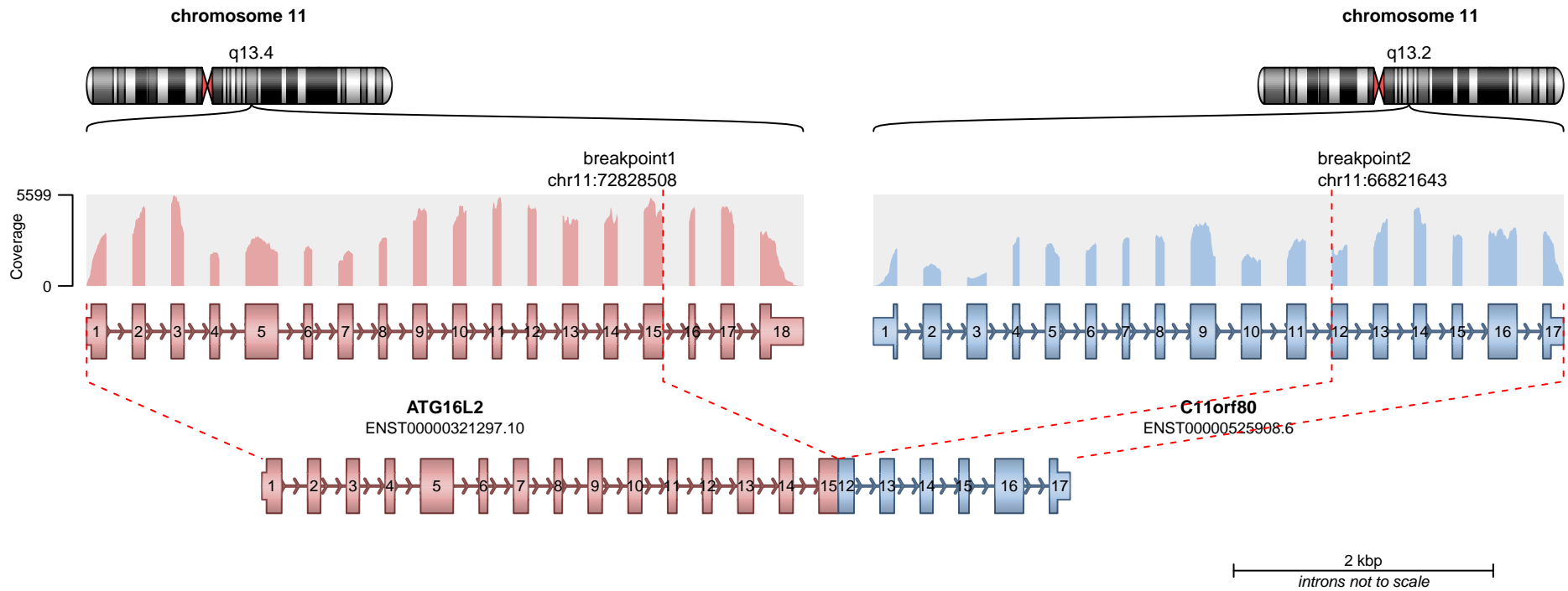

RETAINED PROTEIN DOMAINS
reading frame unclear

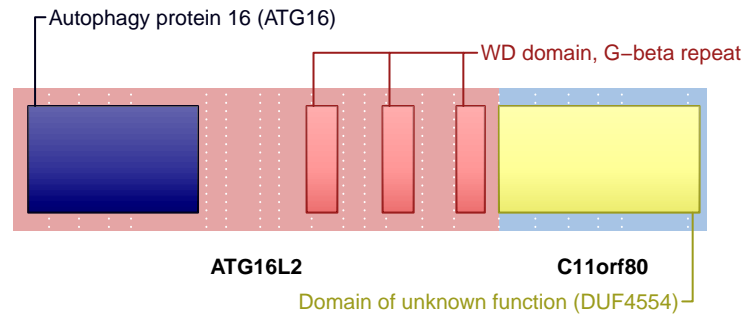

SUPPORTING READ COUNT

Split reads = 41
Discordant mates = 1

— translocation — deletion
— duplication — inversion

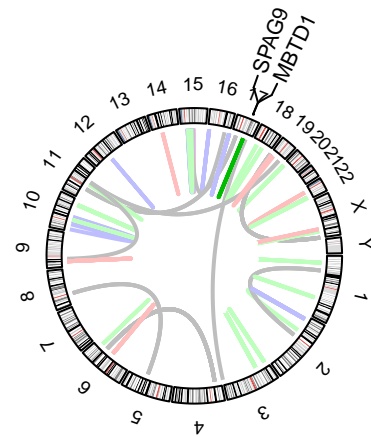
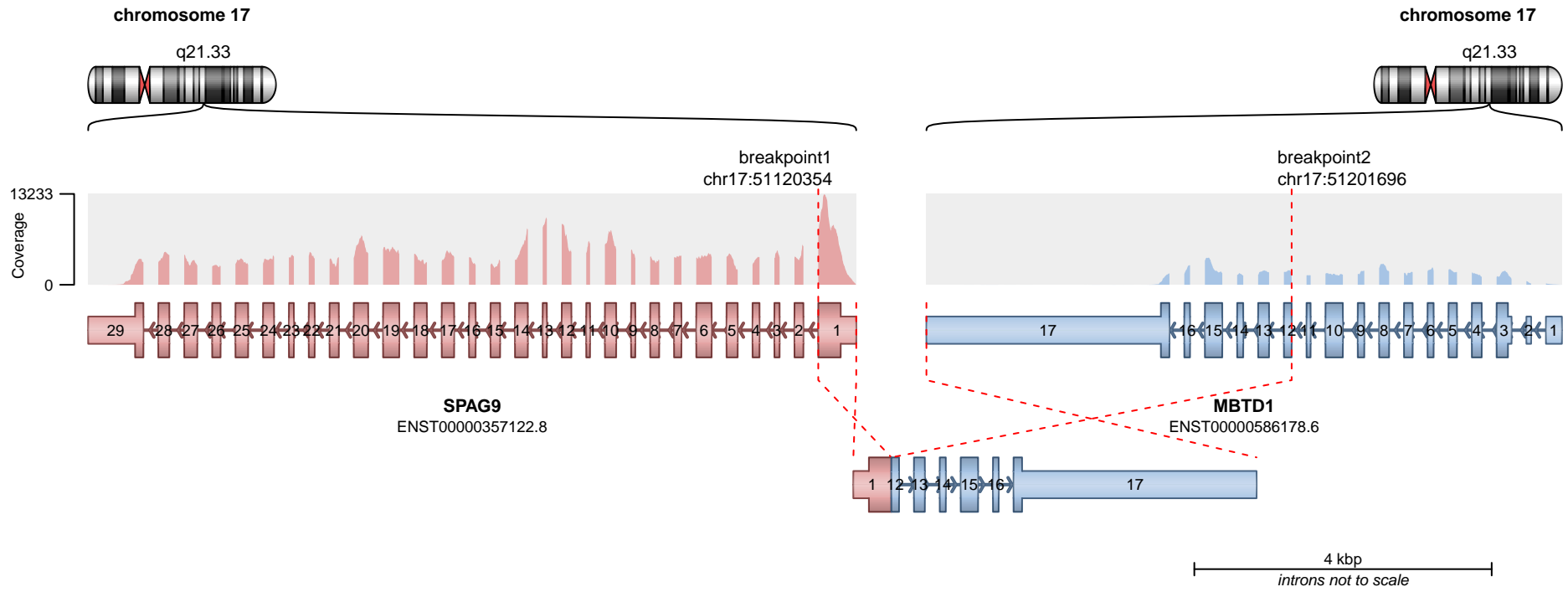

RETAINED PROTEIN DOMAINS
reading frame unclear

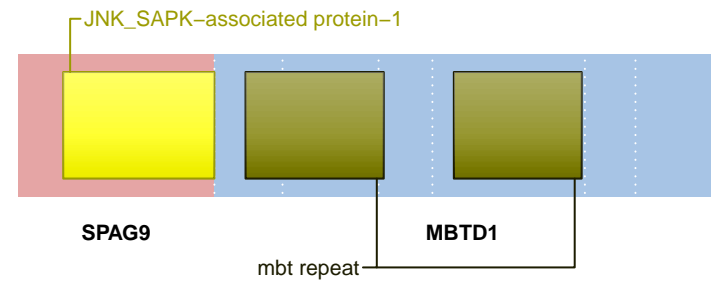

SUPPORTING READ COUNT

Split reads = 40
Discordant mates = 1

- translocation
- duplication
- deletion
- inversion

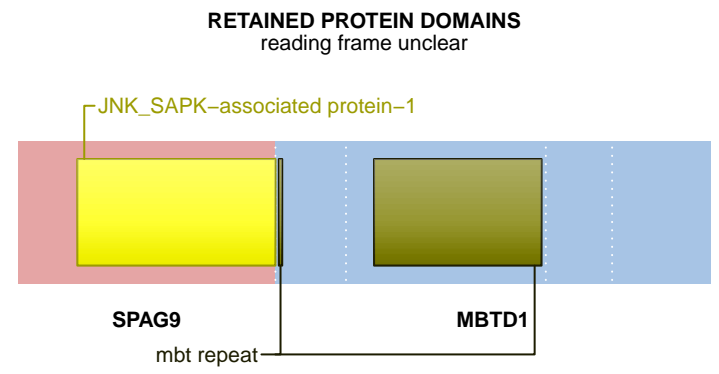
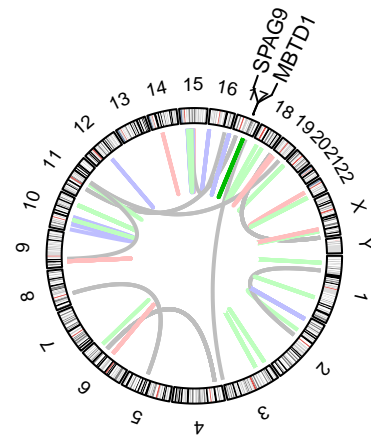
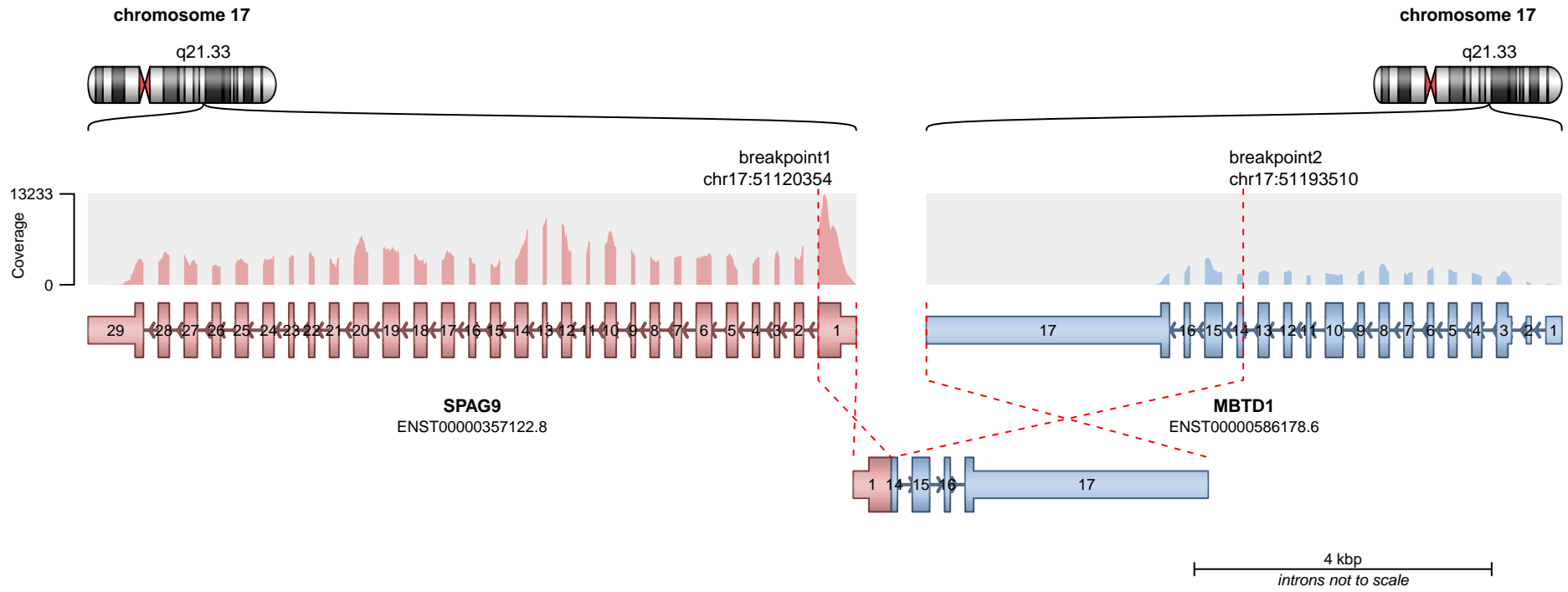

SUPPORTING READ COUNT

Split reads = 2
Discordant mates = 0

— translocation — deletion
— duplication — inversion

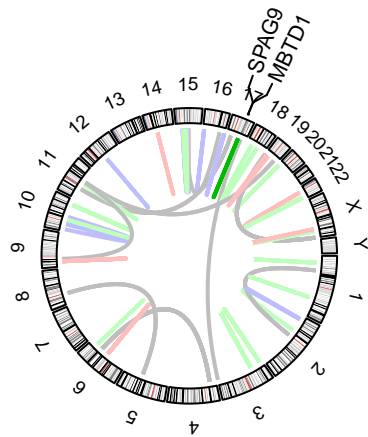
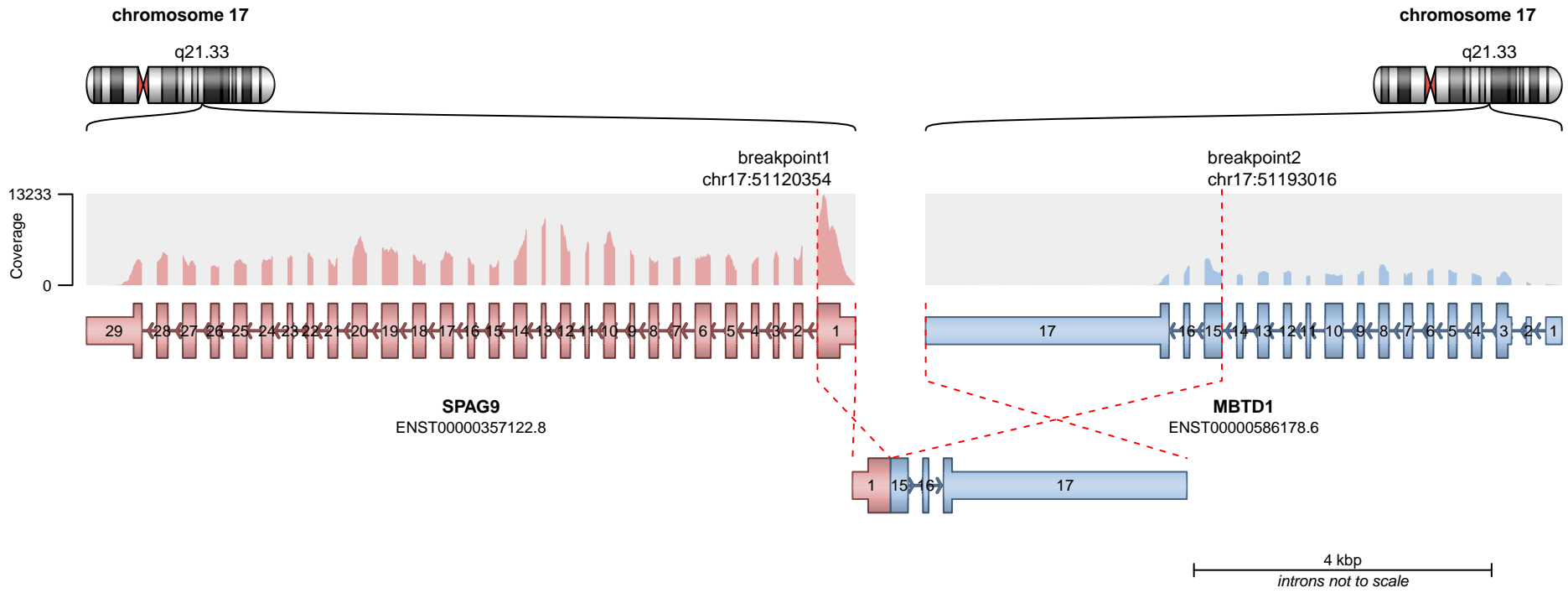

RETAINED PROTEIN DOMAINS
reading frame unclear

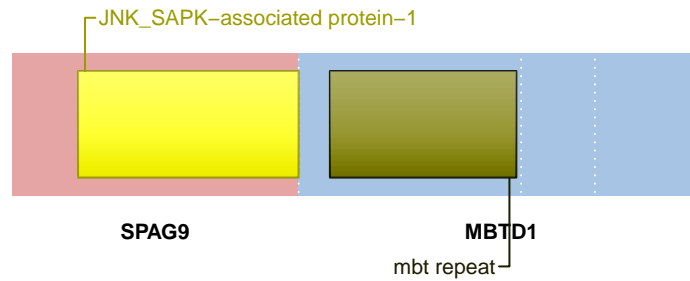

SUPPORTING READ COUNT

Split reads = 2
Discordant mates = 0

- translocation
- duplication
- deletion
- inversion

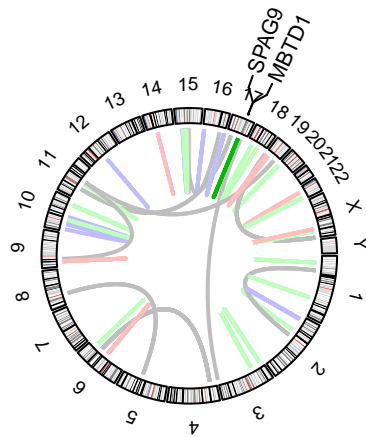
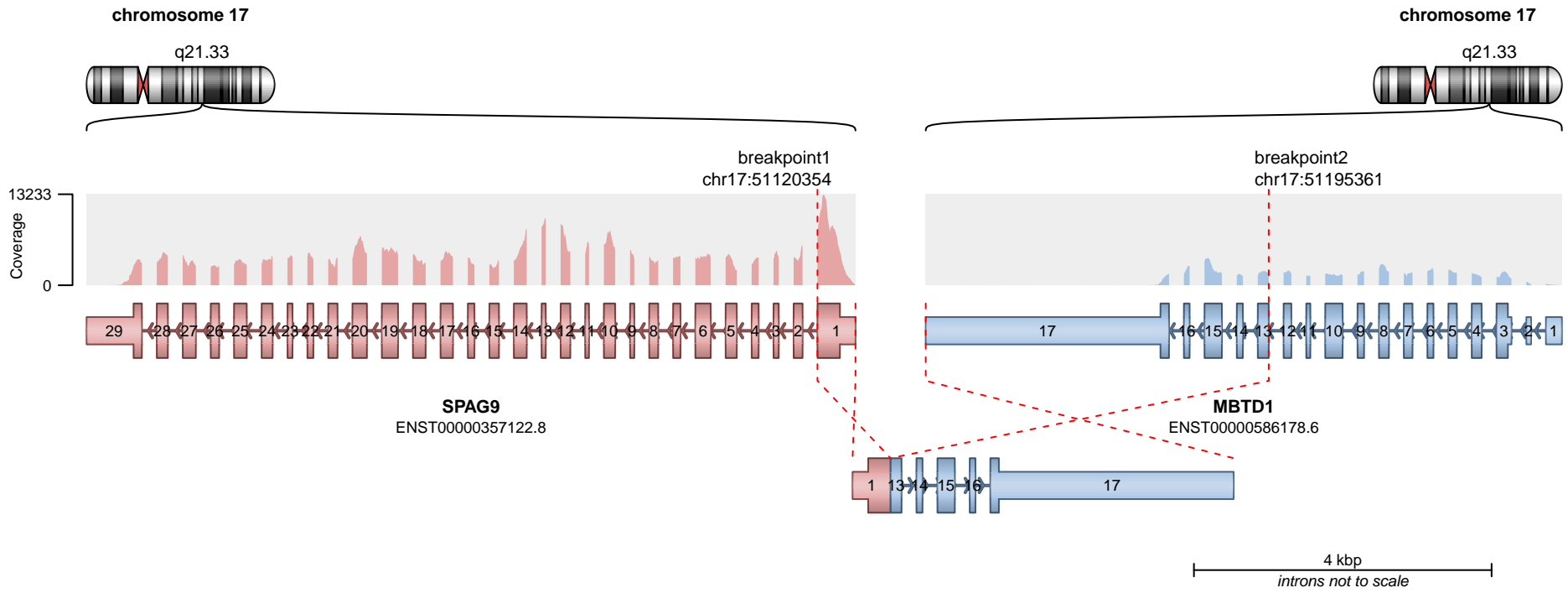

RETAINED PROTEIN DOMAINS
reading frame unclear

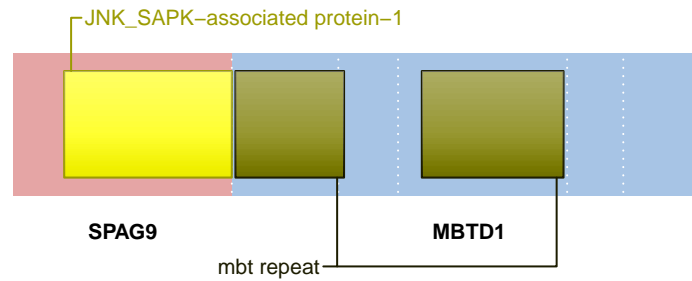

SUPPORTING READ COUNT

Split reads = 1
Discordant mates = 1

- translocation
- duplication
- deletion
- inversion

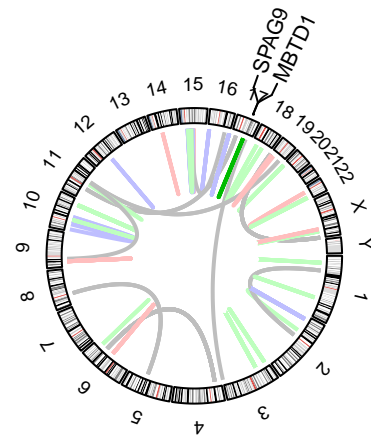
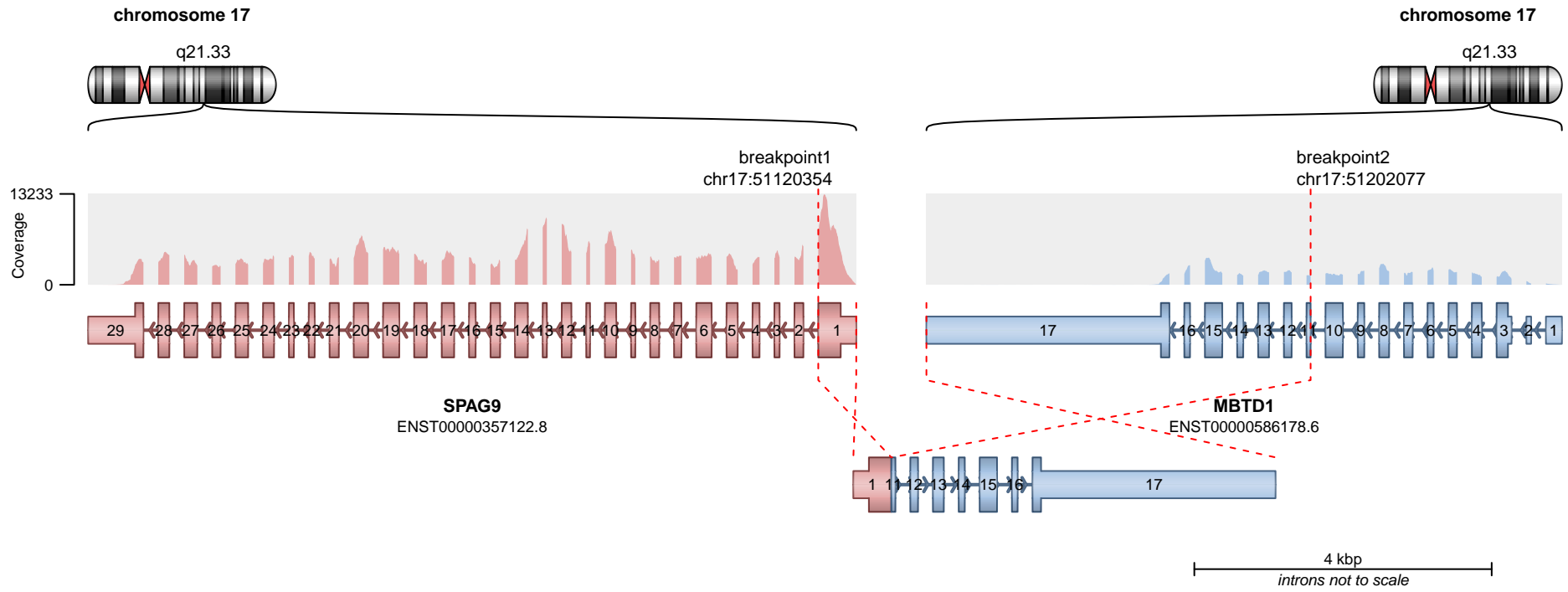

RETAINED PROTEIN DOMAINS
reading frame unclear

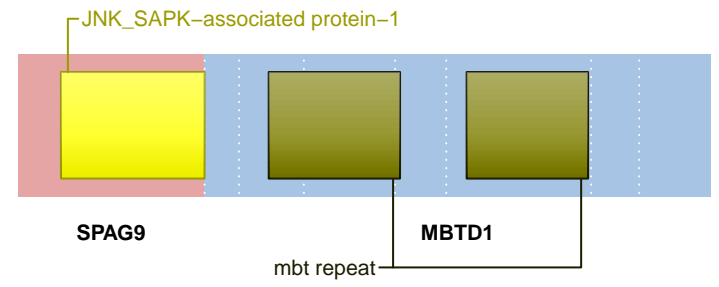

SUPPORTING READ COUNT

Split reads = 1
Discordant mates = 1

- translocation
- duplication
- deletion
- inversion

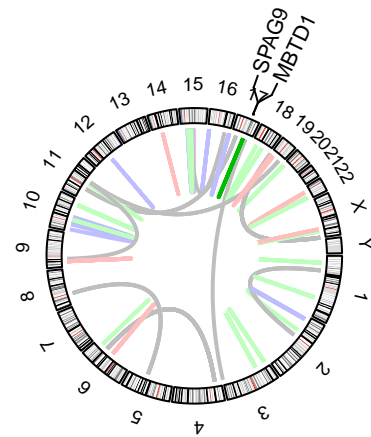
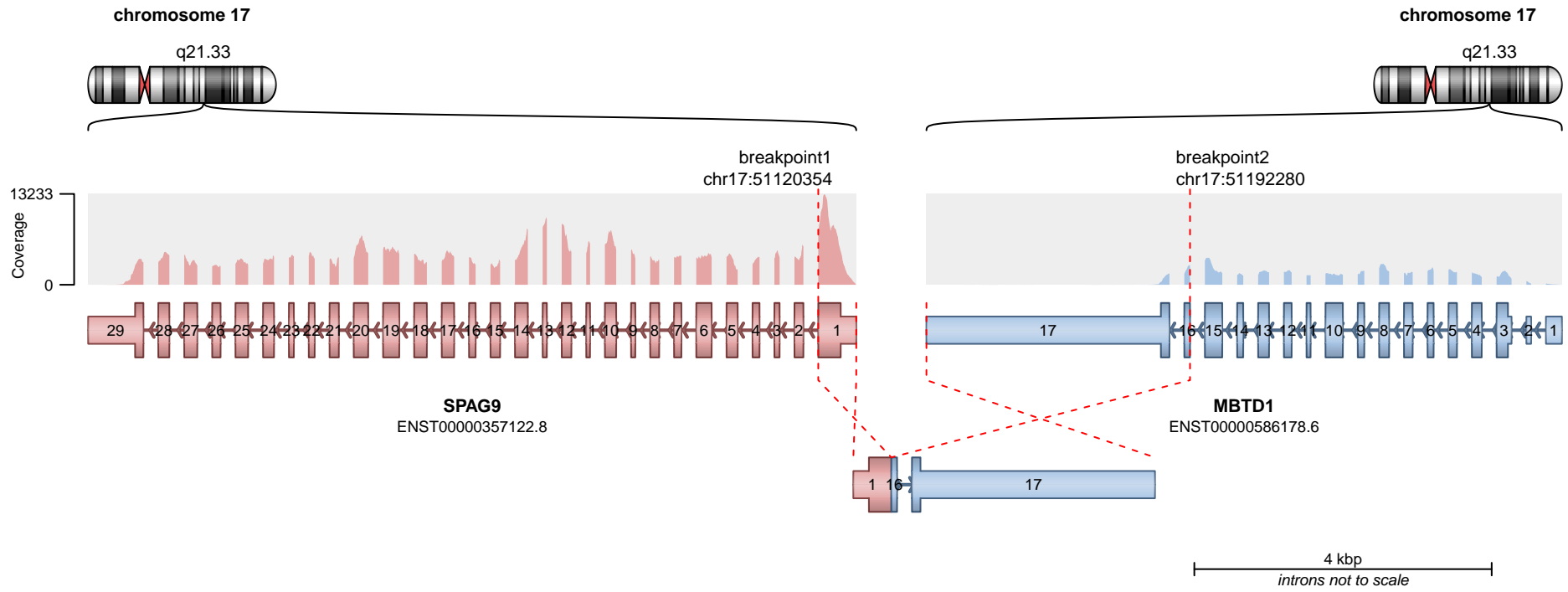

RETAINED PROTEIN DOMAINS
reading frame unclear

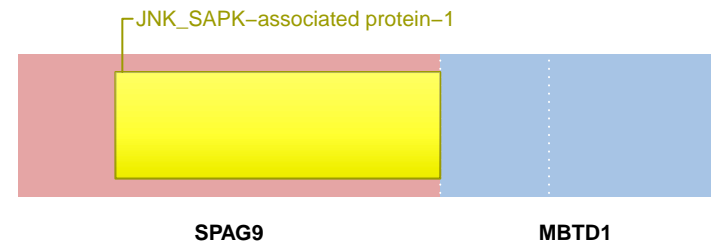

SUPPORTING READ COUNT

Split reads = 1
Discordant mates = 0

- translocation
- duplication
- deletion
- inversion

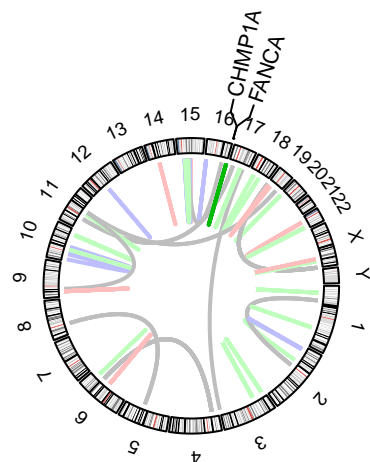
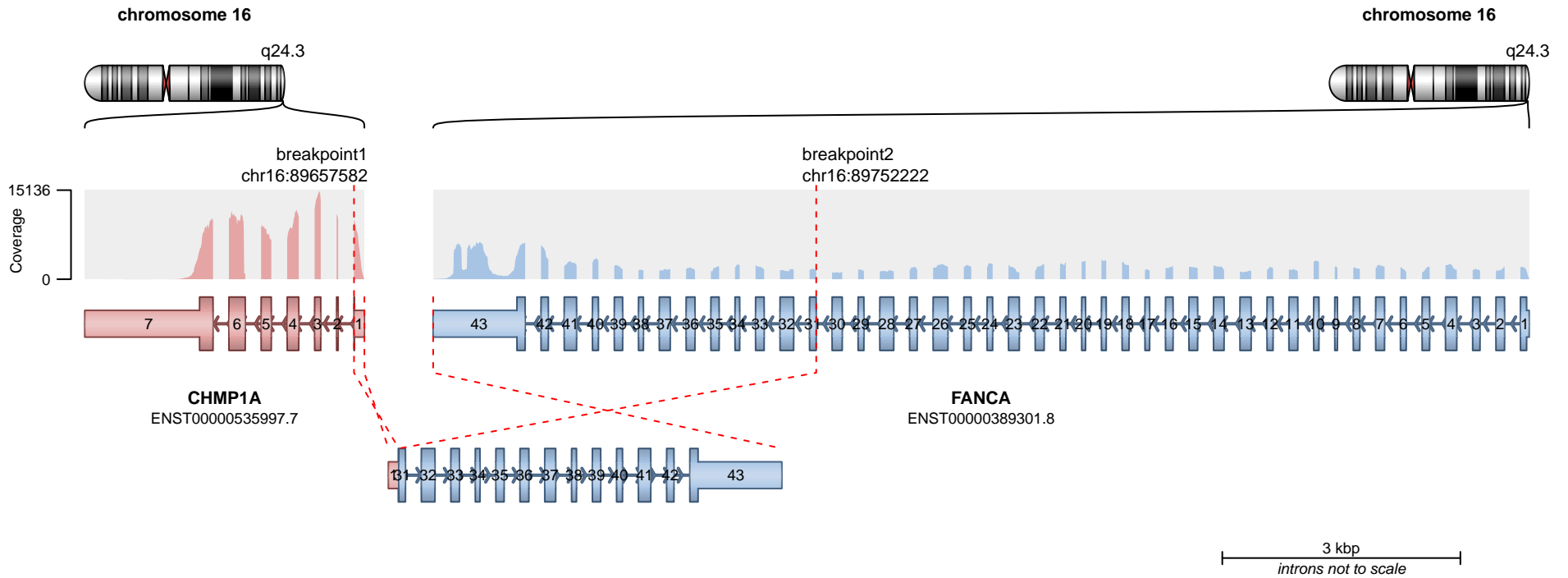

RETAINED PROTEIN DOMAINS
reading frame unclear

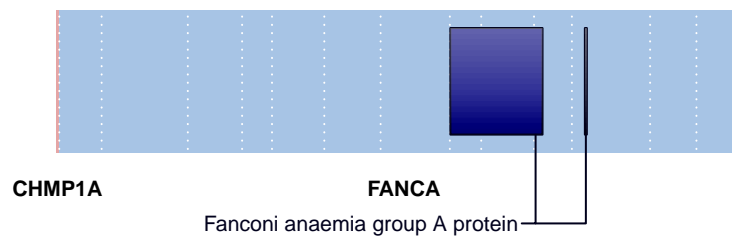

SUPPORTING READ COUNT

Split reads = 39
Discordant mates = 0

- translocation
- duplication
- deletion
- inversion

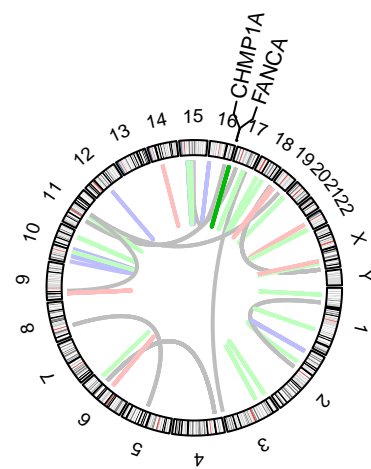
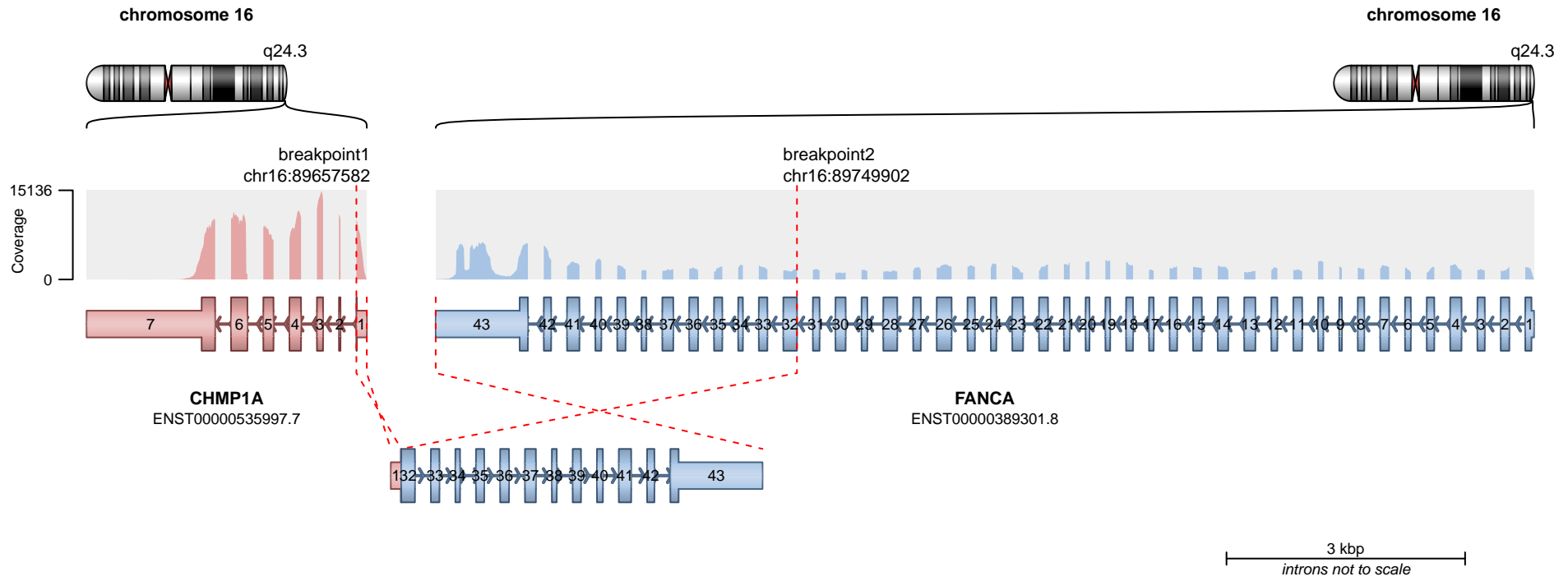

RETAINED PROTEIN DOMAINS
reading frame unclear

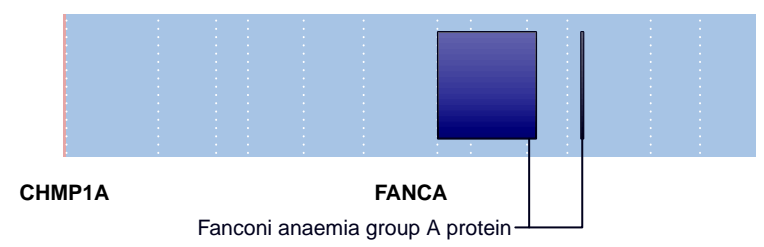

SUPPORTING READ COUNT

Split reads = 2
Discordant mates = 0

- translocation
- duplication
- deletion
- inversion

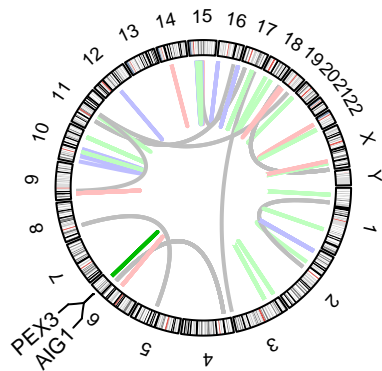
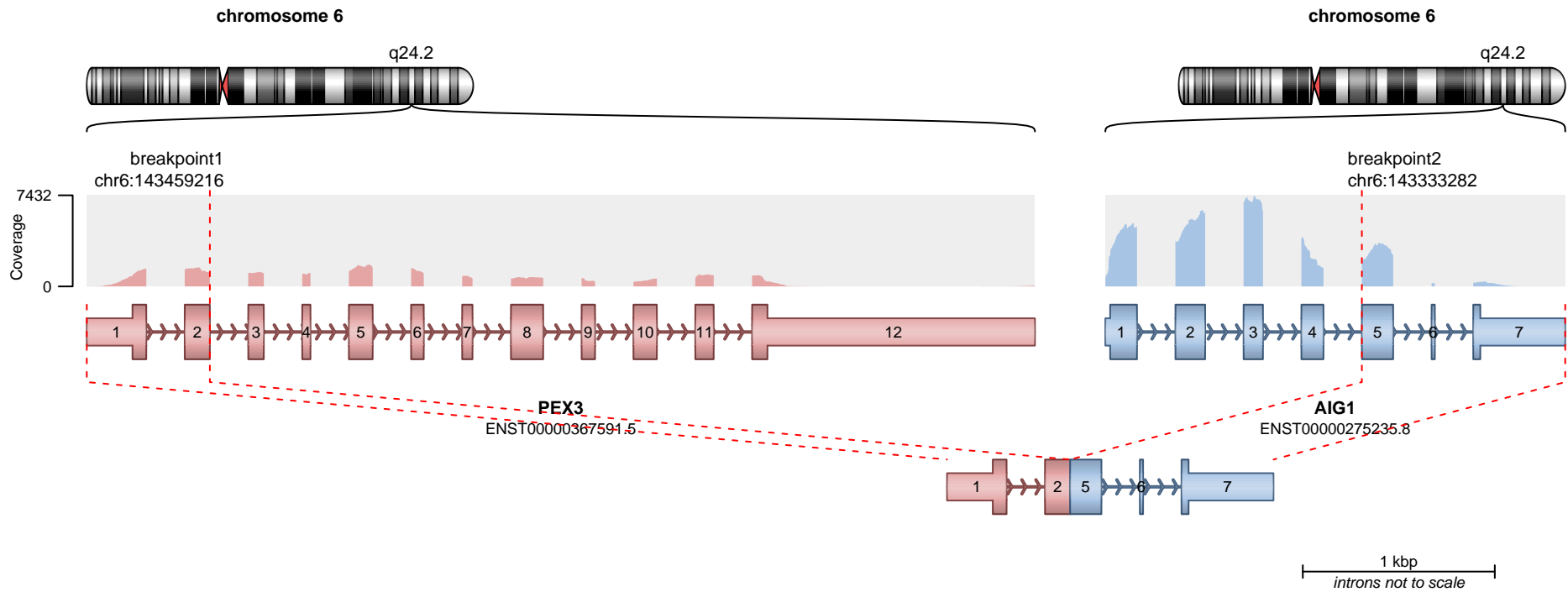

RETAINED PROTEIN DOMAINS
reading frame unclear

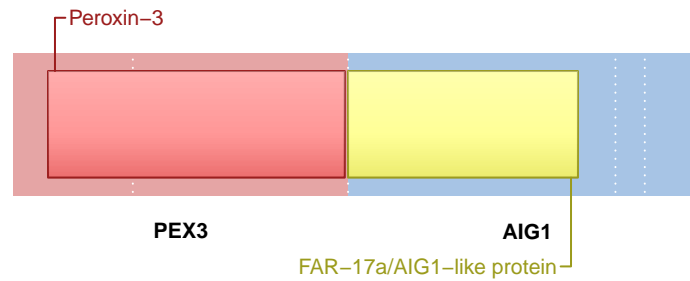

SUPPORTING READ COUNT

Split reads = 37
Discordant mates = 3

- translocation
- duplication
- deletion
- inversion

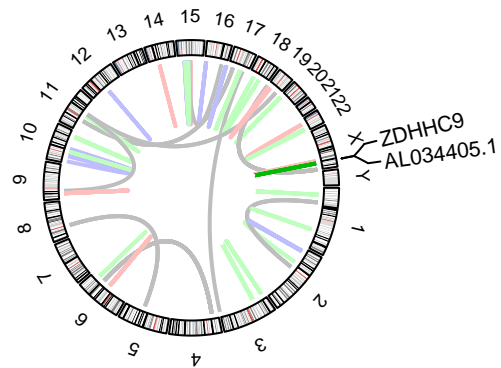
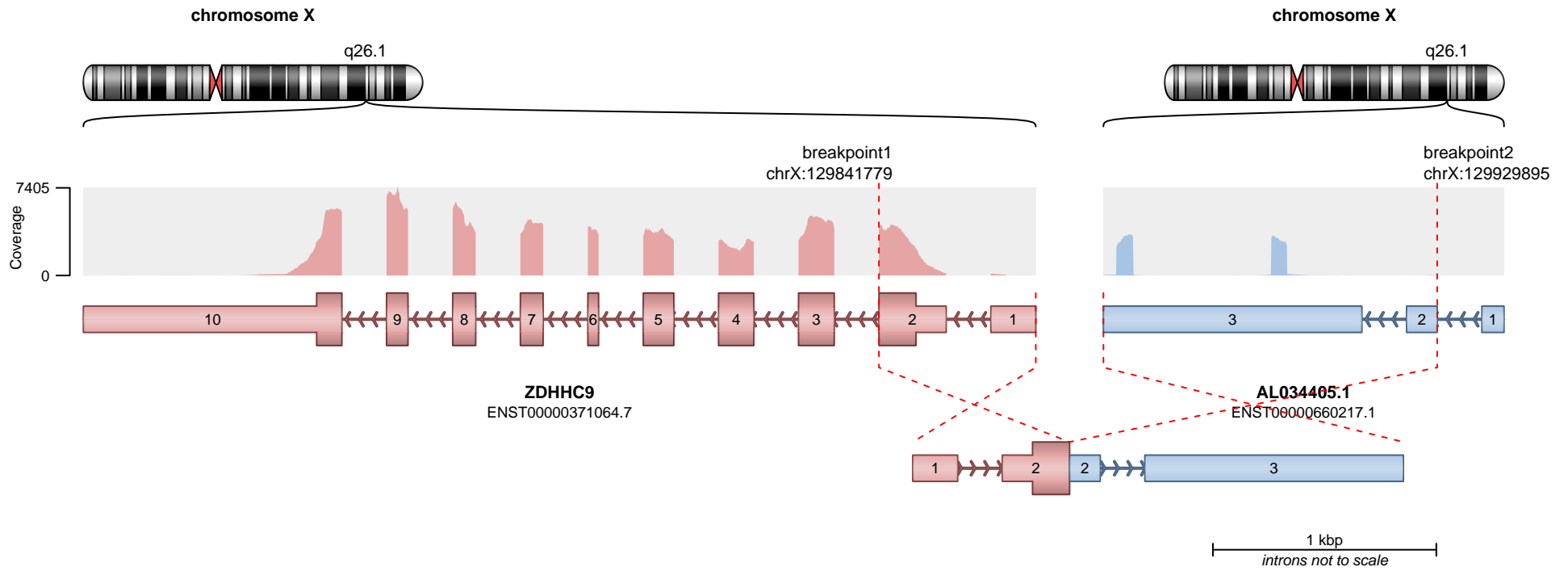

— translocation — deletion
 — duplication — inversion

No protein domains retained in fusion.

SUPPORTING READ COUNT

Split reads = 36
 Discordant mates = 0

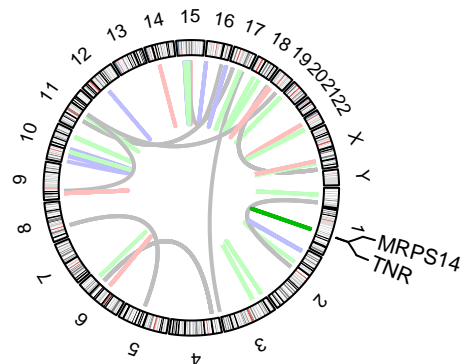
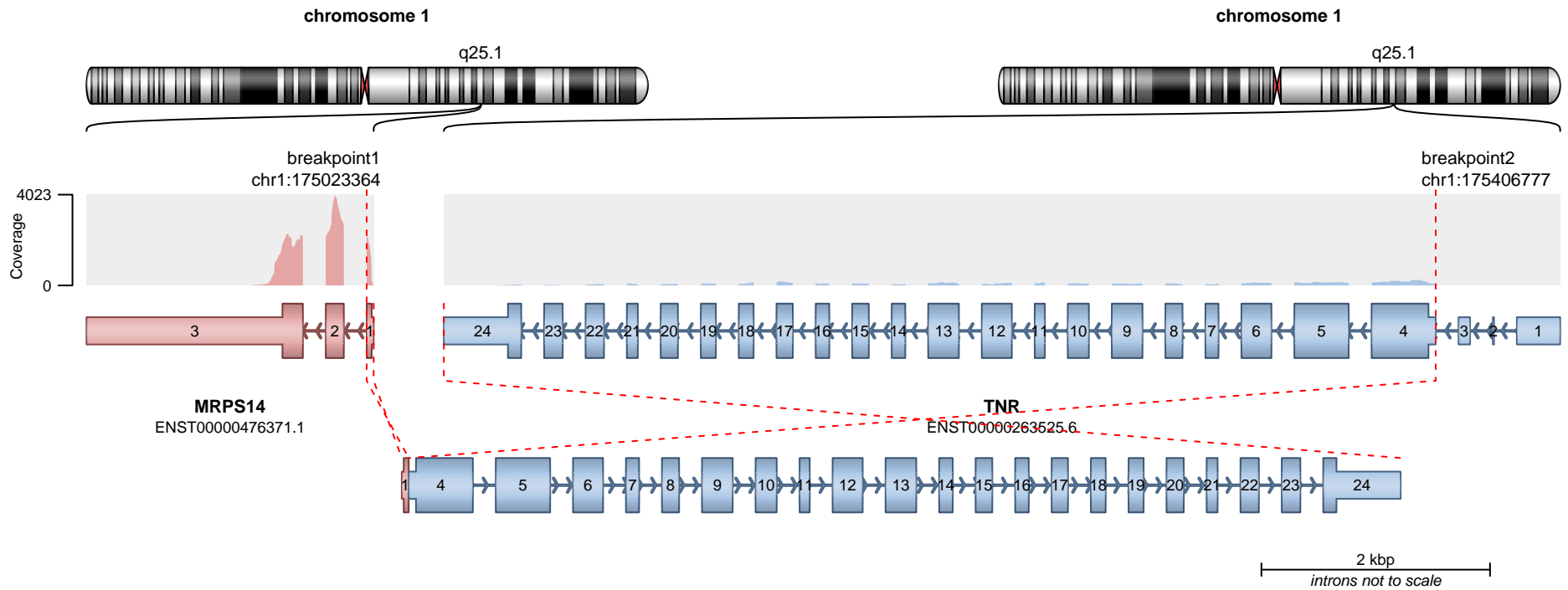

— translocation — deletion
— duplication — inversion

RETAINED PROTEIN DOMAINS
reading frame unclear

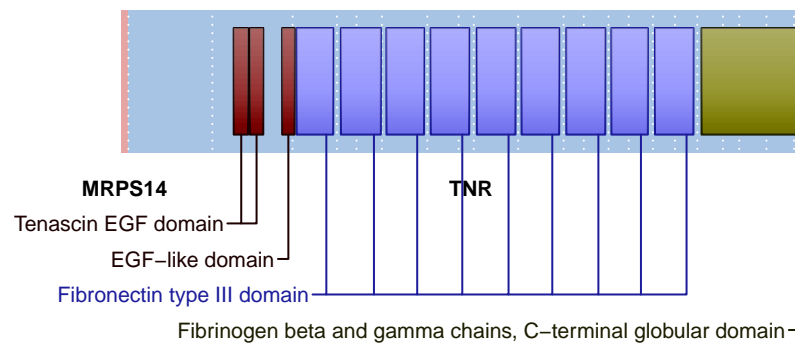

SUPPORTING READ COUNT

Split reads = 32
Discordant mates = 0

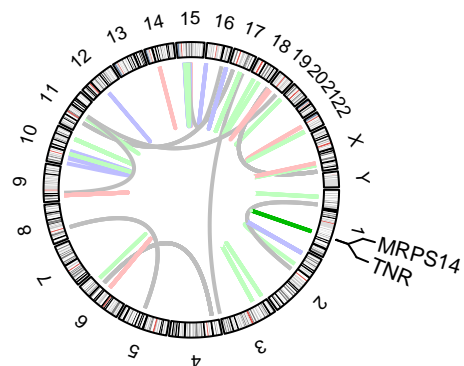
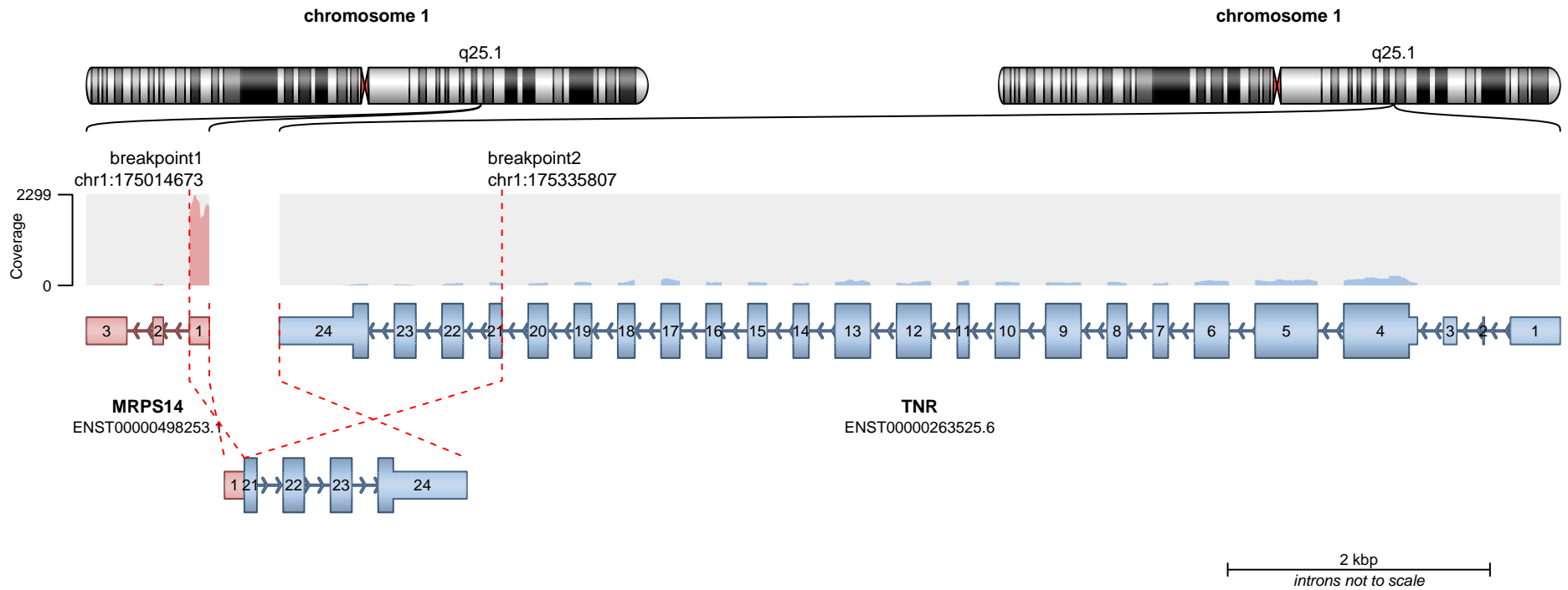

RETAINED PROTEIN DOMAINS
reading frame unclear

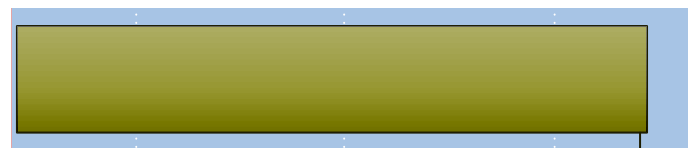

TNR

Fibrinogen beta and gamma chains, C-terminal globular domain

SUPPORTING READ COUNT

Split reads = 1
Discordant mates = 0

— translocation — deletion
— duplication — inversion

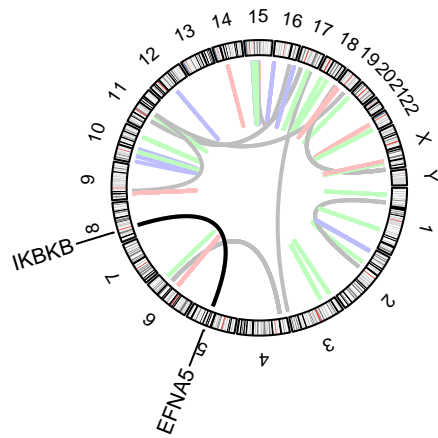
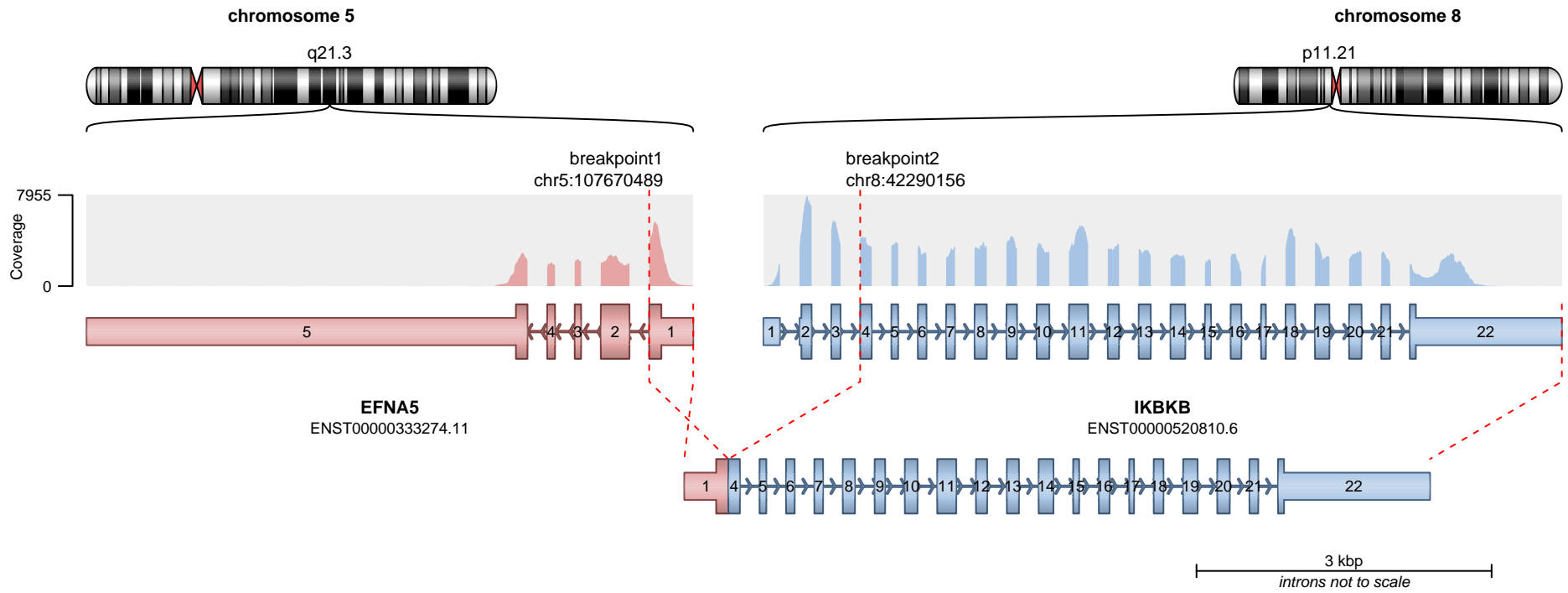

RETAINED PROTEIN DOMAINS
reading frame unclear

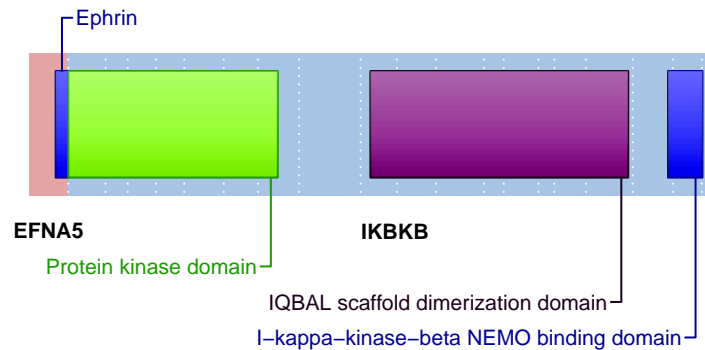

SUPPORTING READ COUNT

Split reads = 30
Discordant mates = 0

— translocation — deletion
— duplication — inversion

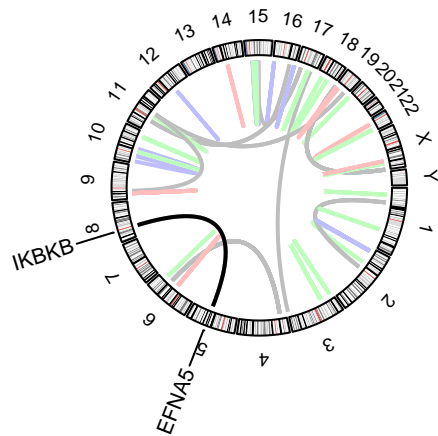
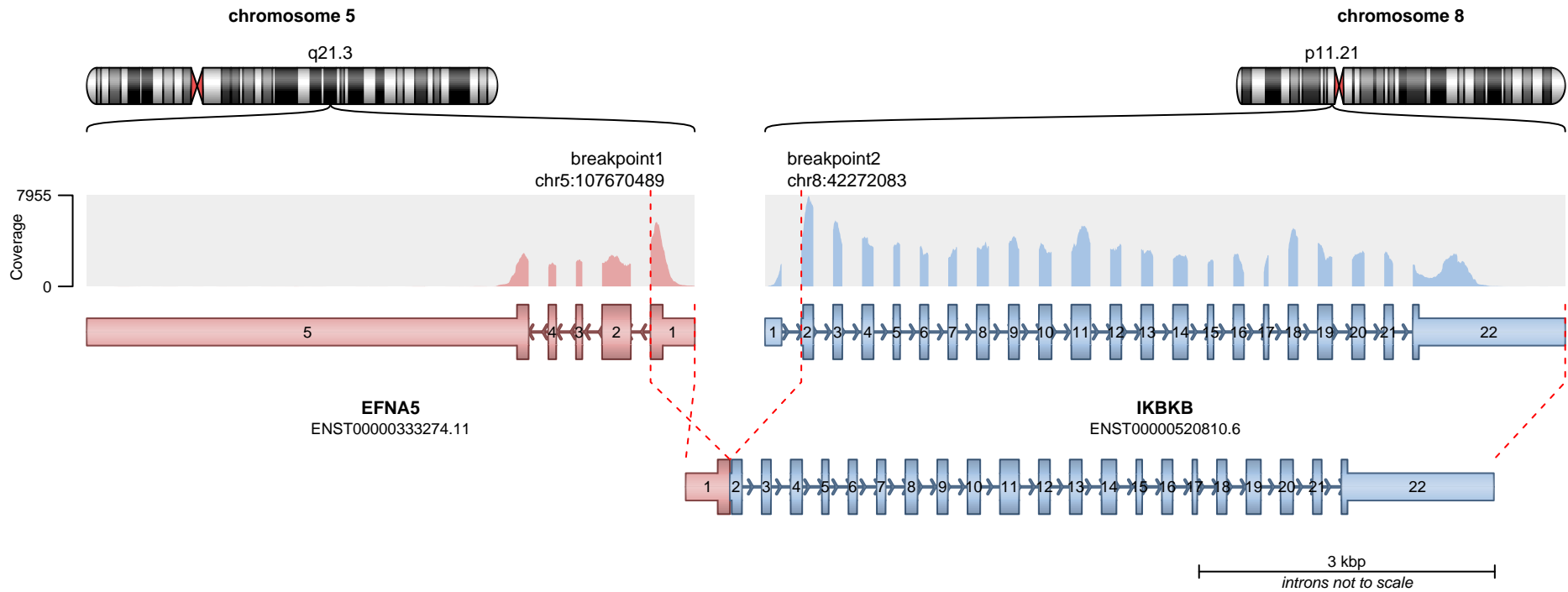

— translocation — deletion
— duplication — inversion

RETAINED PROTEIN DOMAINS
reading frame unclear

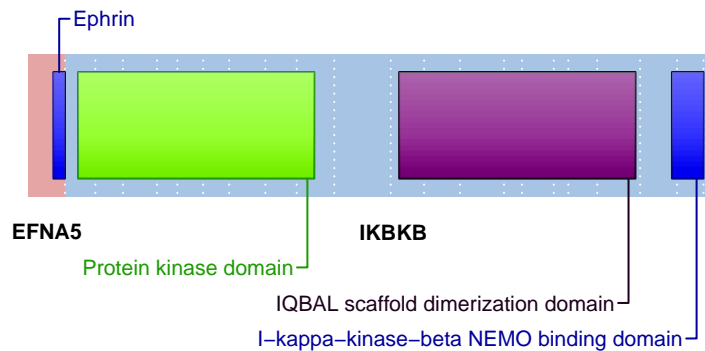

SUPPORTING READ COUNT

Split reads = 2
Discordant mates = 1

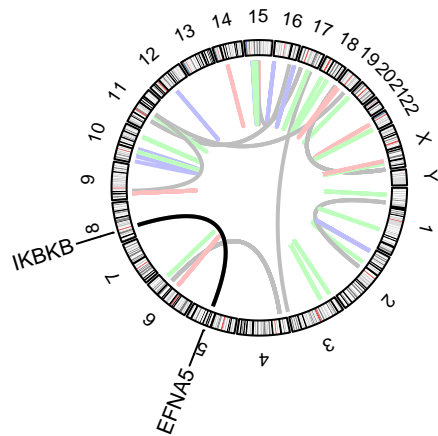
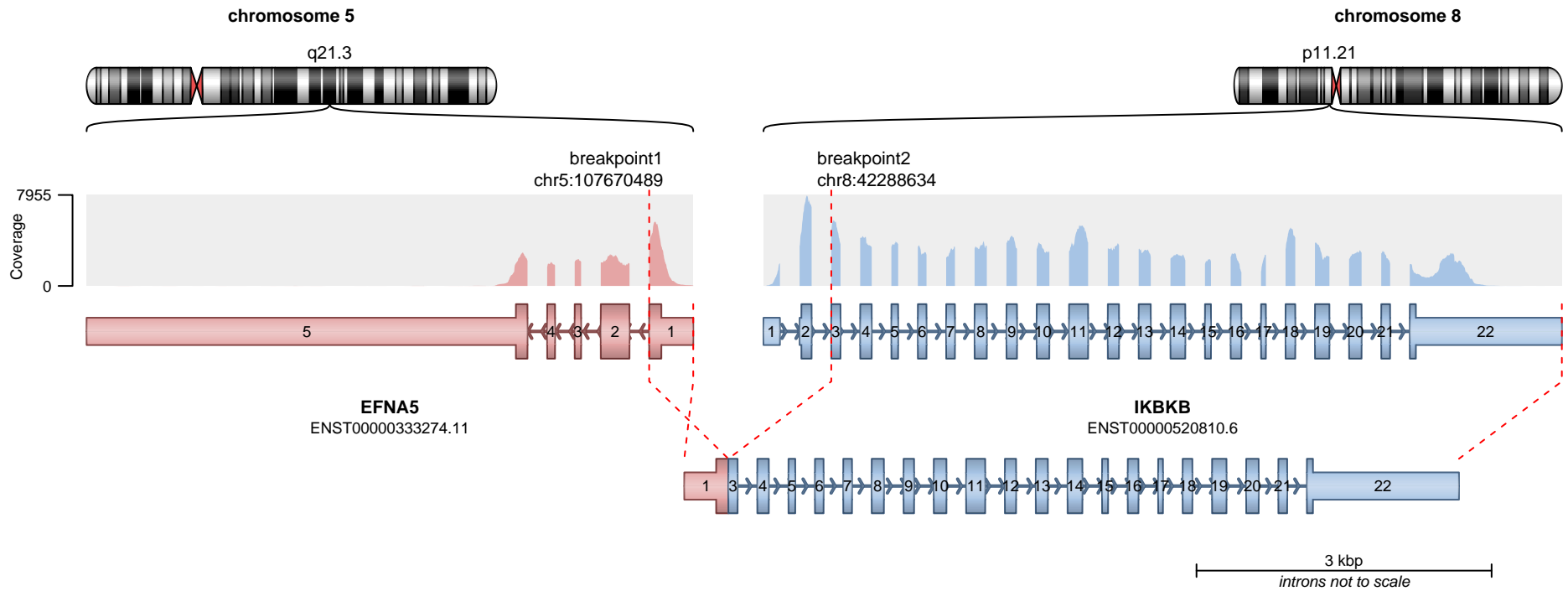

— translocation — deletion
— duplication — inversion

RETAINED PROTEIN DOMAINS
reading frame unclear

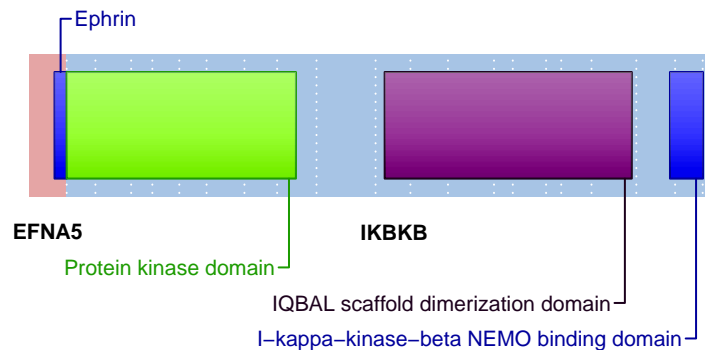

SUPPORTING READ COUNT

Split reads = 1
Discordant mates = 1

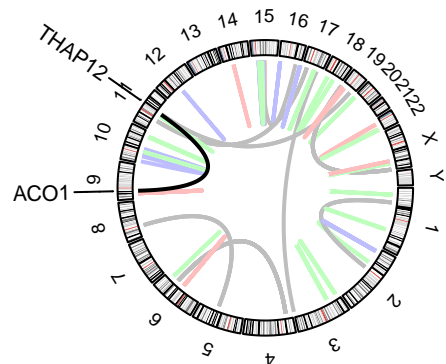
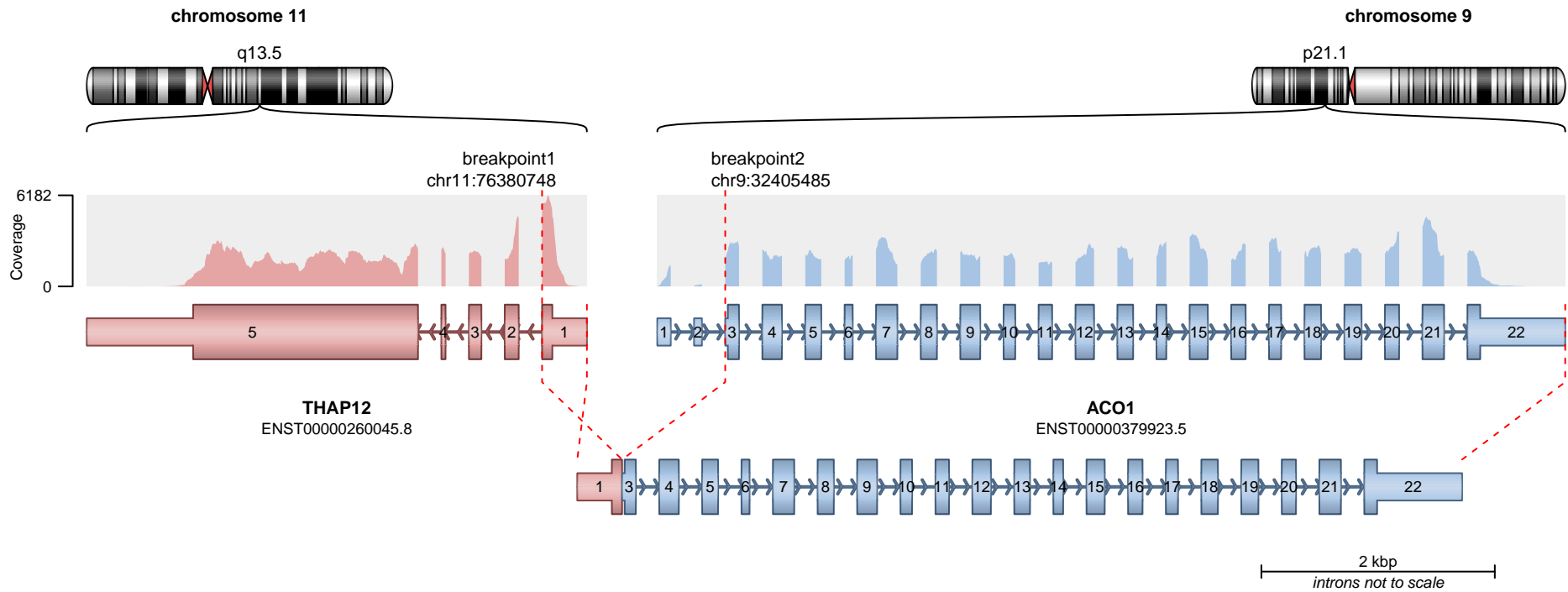

RETAINED PROTEIN DOMAINS
reading frame unclear

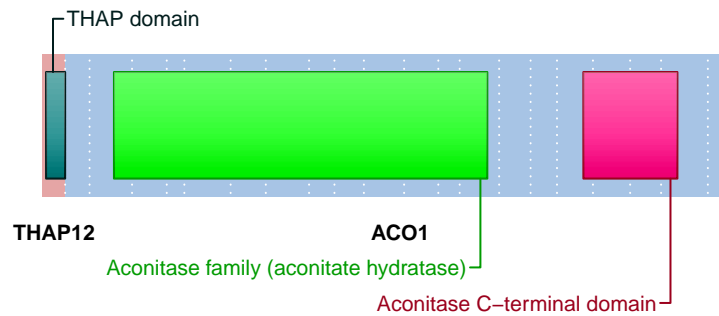

SUPPORTING READ COUNT

Split reads = 27
Discordant mates = 1

— translocation — deletion
— duplication — inversion

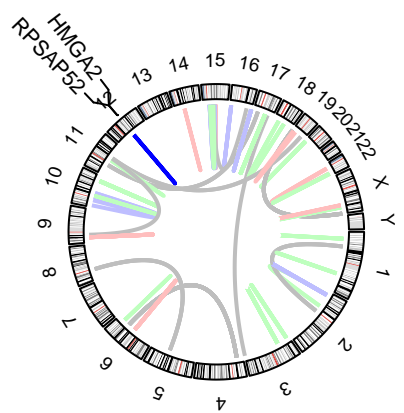
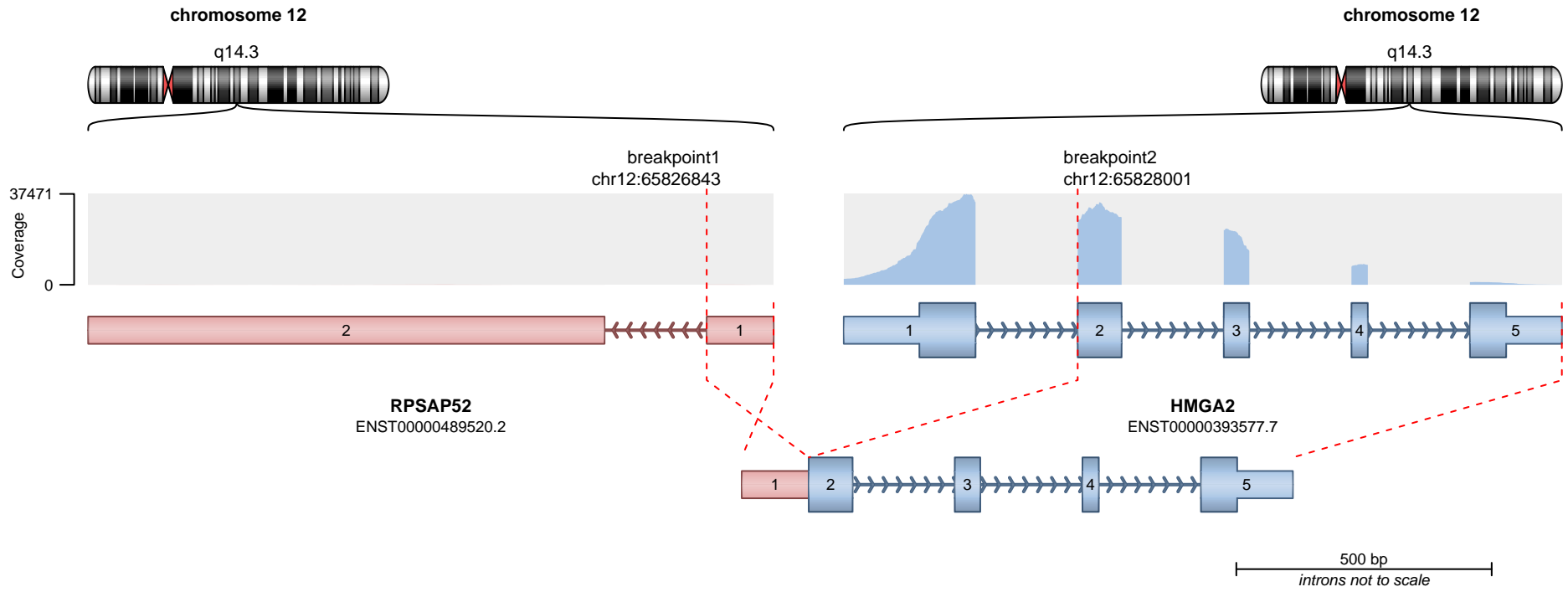

RETAINED PROTEIN DOMAINS
reading frame unclear

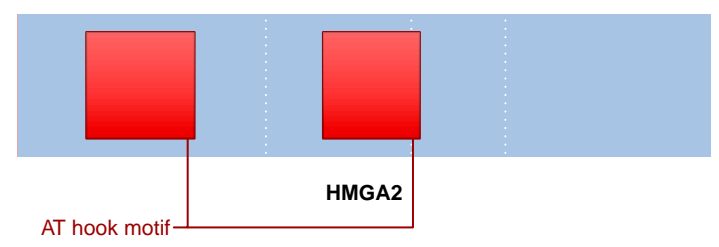

SUPPORTING READ COUNT

Split reads = 27
Discordant mates = 0

- translocation
- duplication
- deletion
- inversion

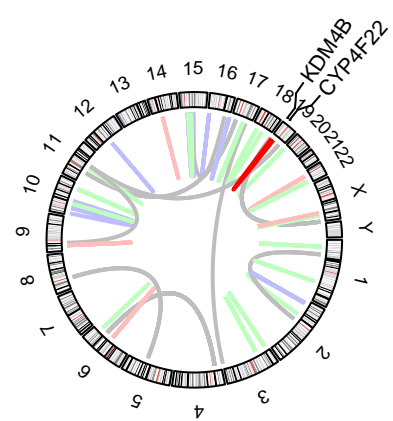
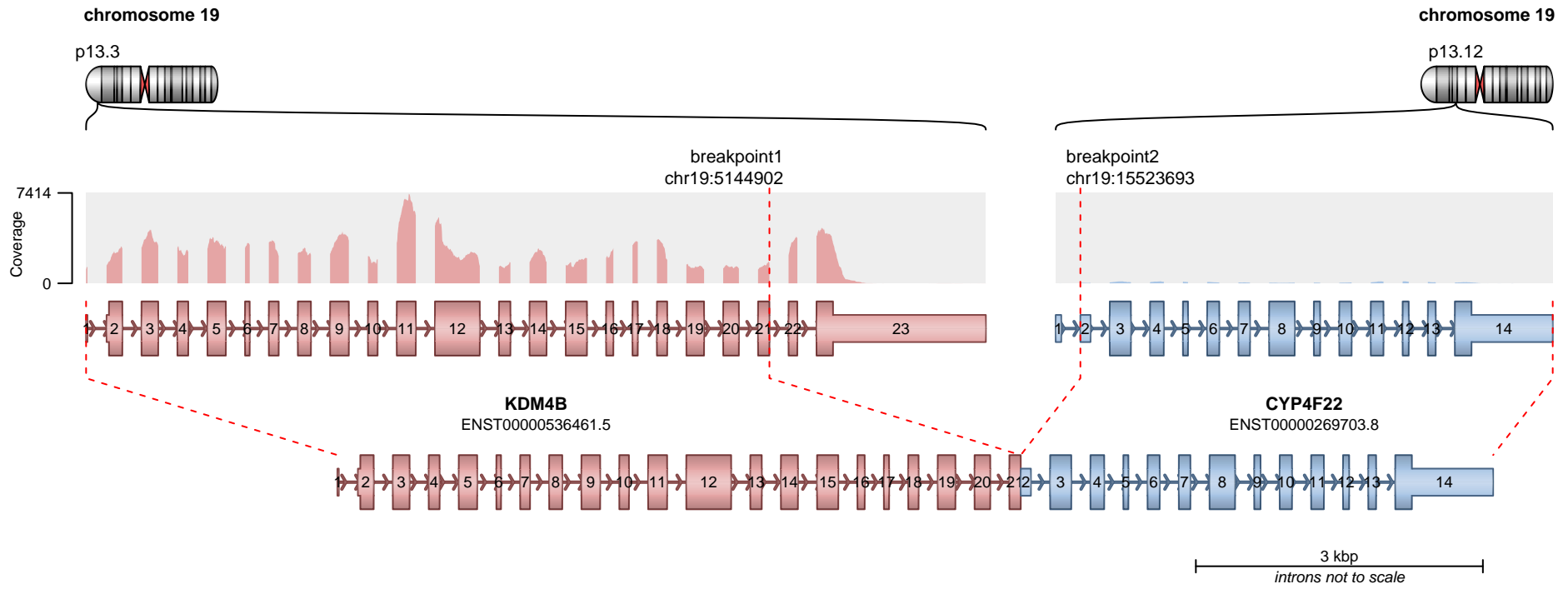

RETAINED PROTEIN DOMAINS
reading frame unclear

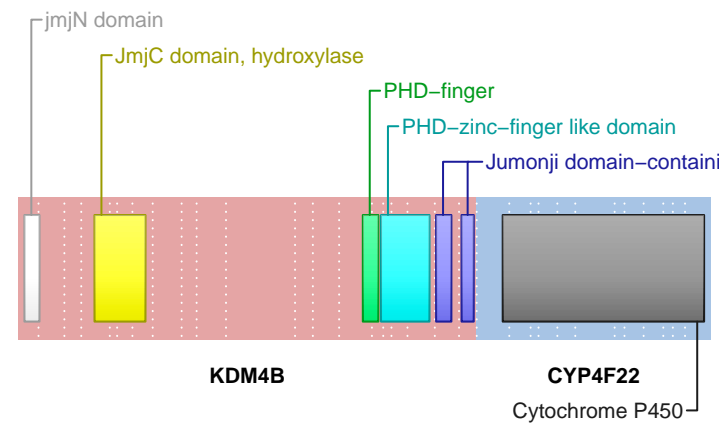

SUPPORTING READ COUNT

Split reads = 26
Discordant mates = 0

— translocation — deletion
— duplication — inversion

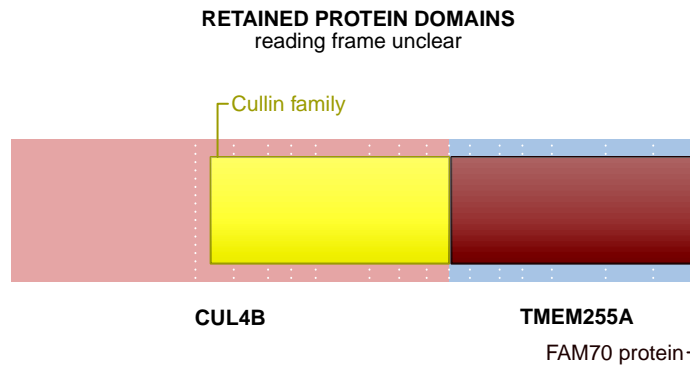
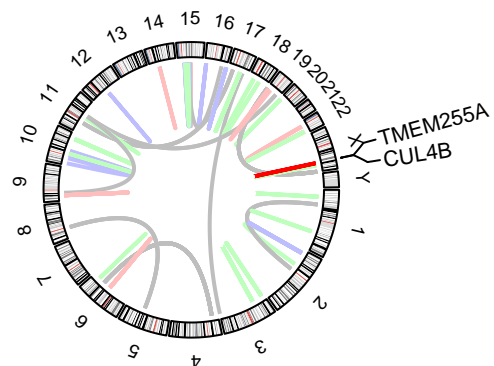
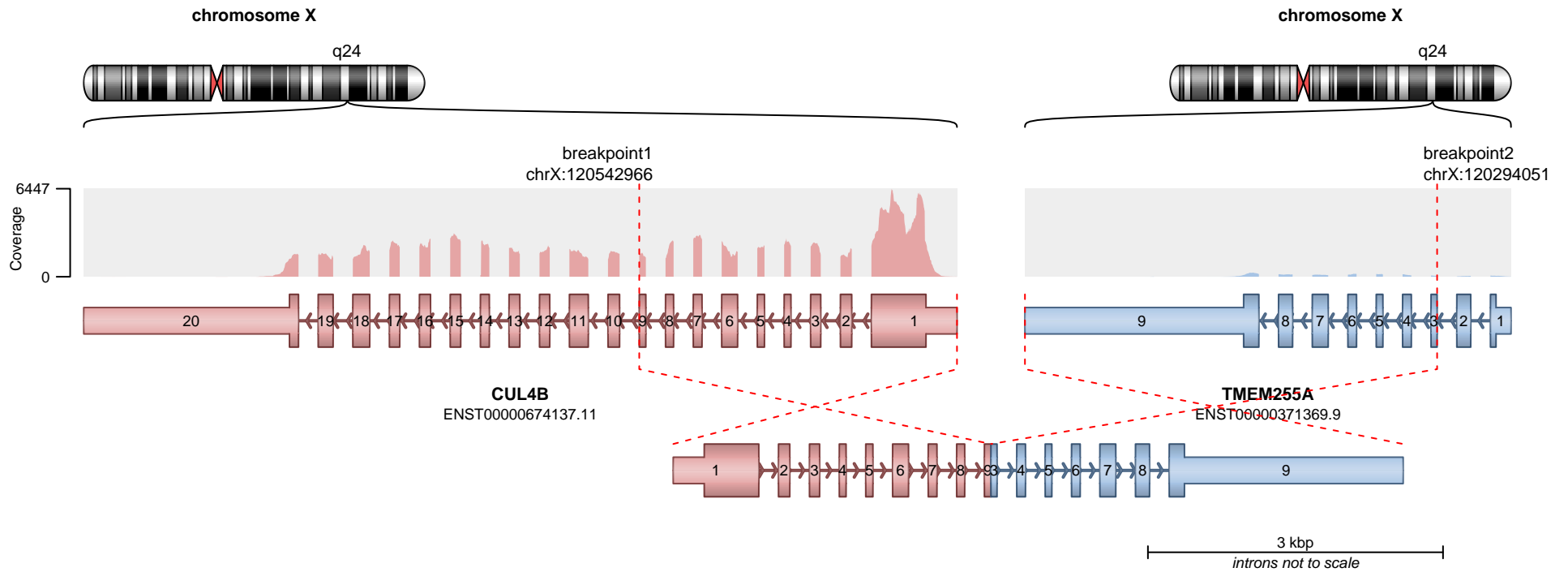

SUPPORTING READ COUNT

Split reads = 22
Discordant mates = 0

— translocation — deletion
— duplication — inversion

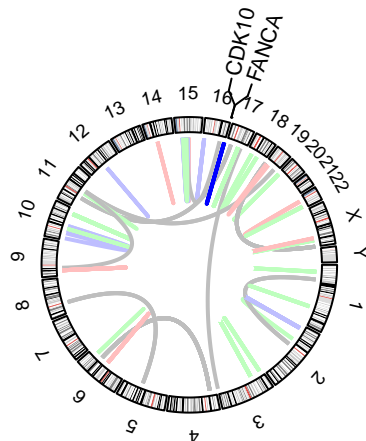
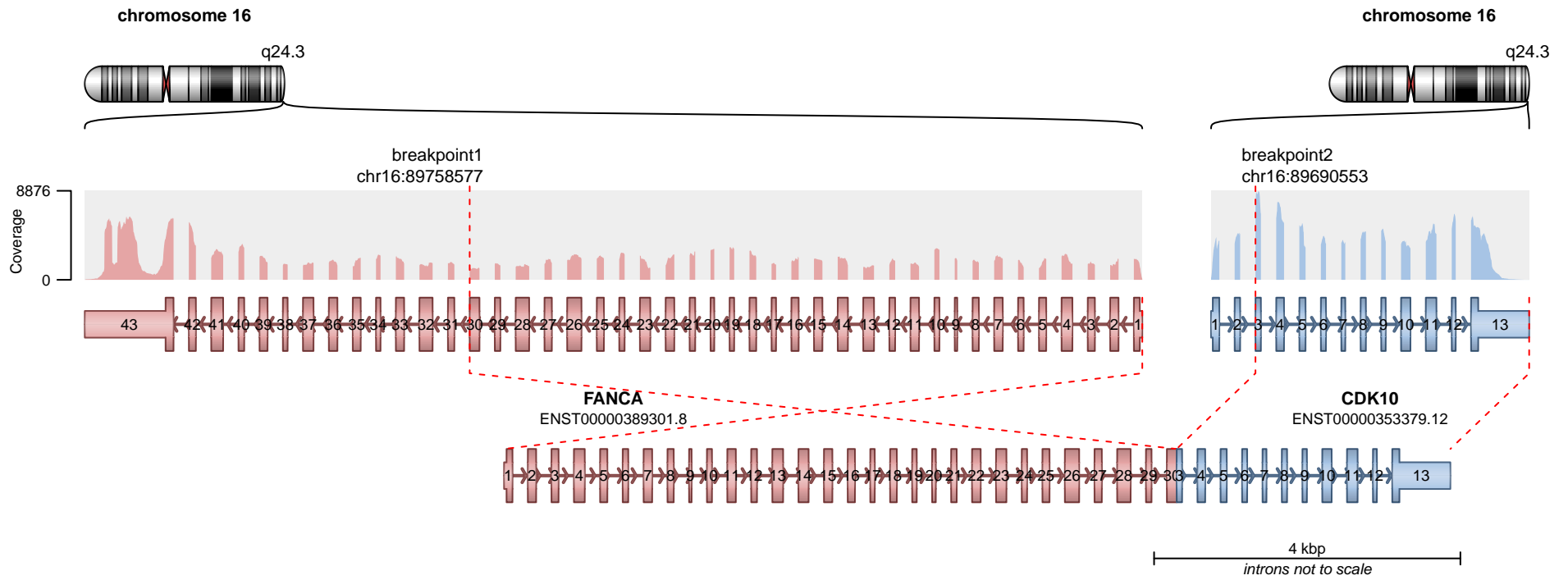

RETAINED PROTEIN DOMAINS
reading frame unclear

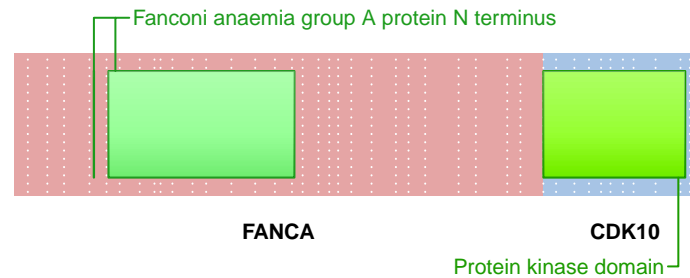

SUPPORTING READ COUNT

Split reads = 20
Discordant mates = 1

- translocation
- duplication
- deletion
- inversion

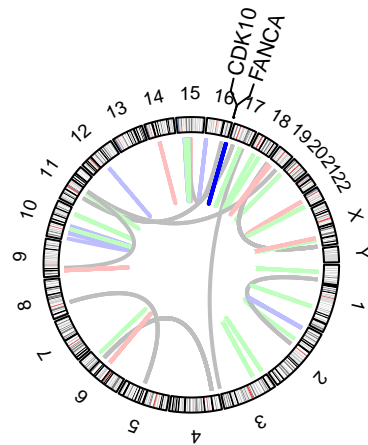
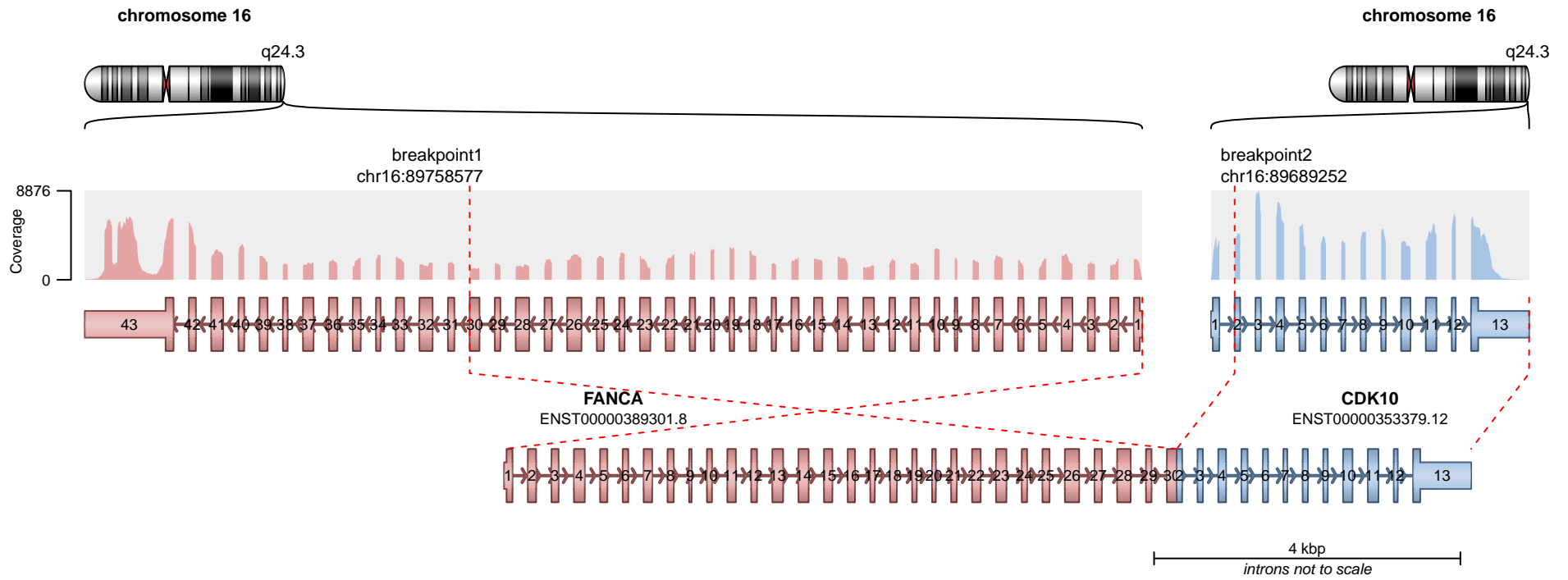

RETAINED PROTEIN DOMAINS
reading frame unclear

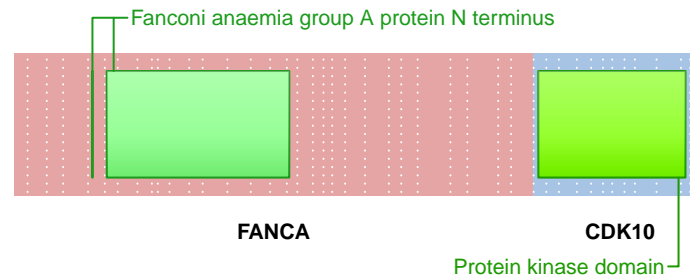

SUPPORTING READ COUNT

Split reads = 17
Discordant mates = 2

— translocation — deletion
— duplication — inversion

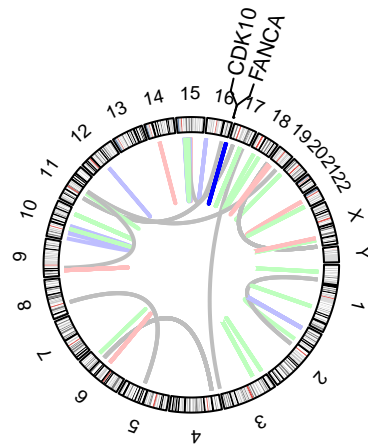
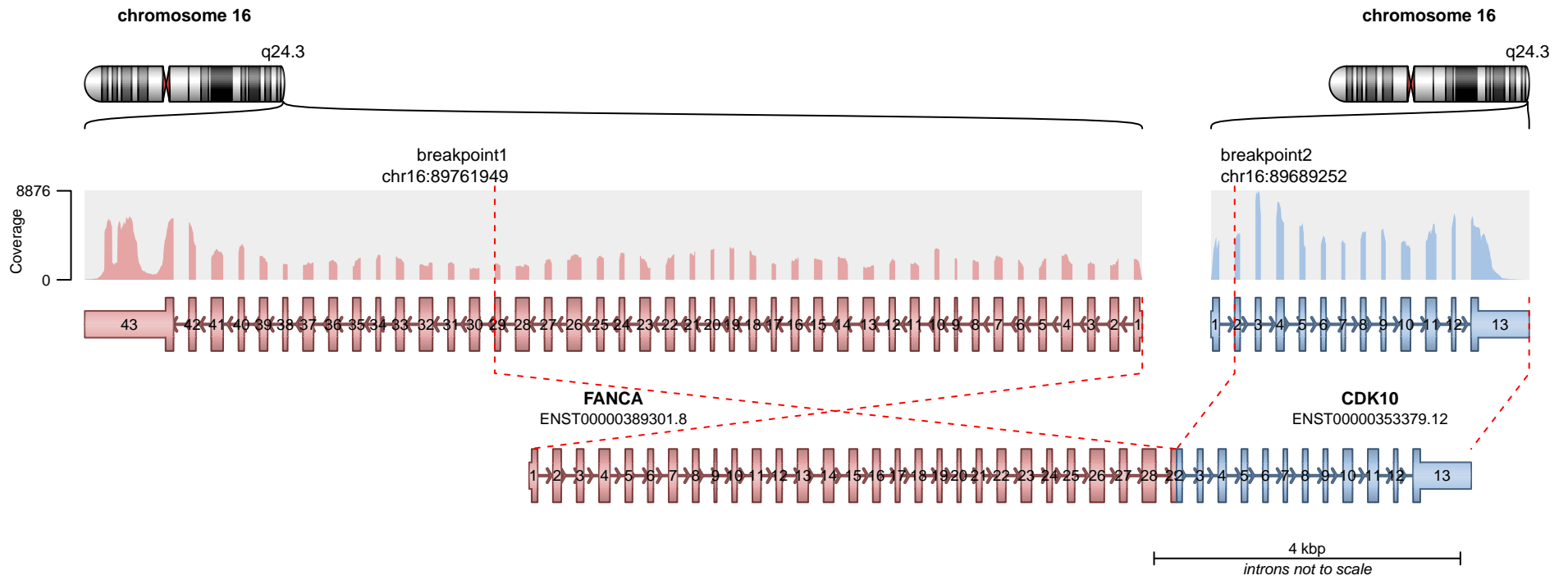

RETAINED PROTEIN DOMAINS
reading frame unclear

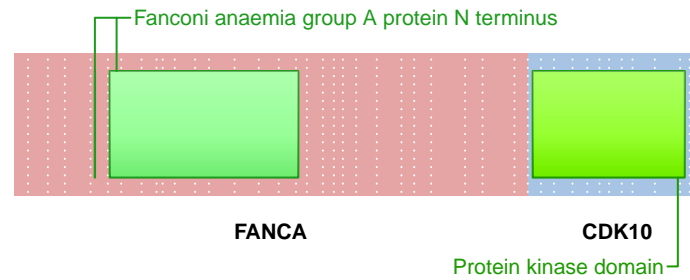

SUPPORTING READ COUNT

Split reads = 1
Discordant mates = 1

— translocation — deletion
— duplication — inversion

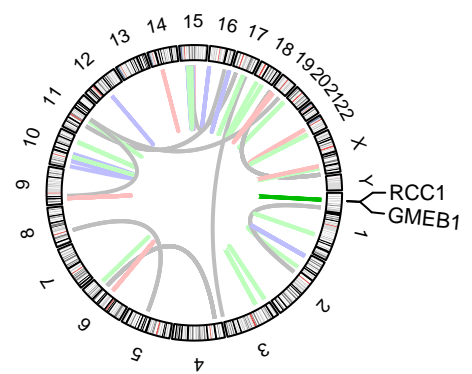
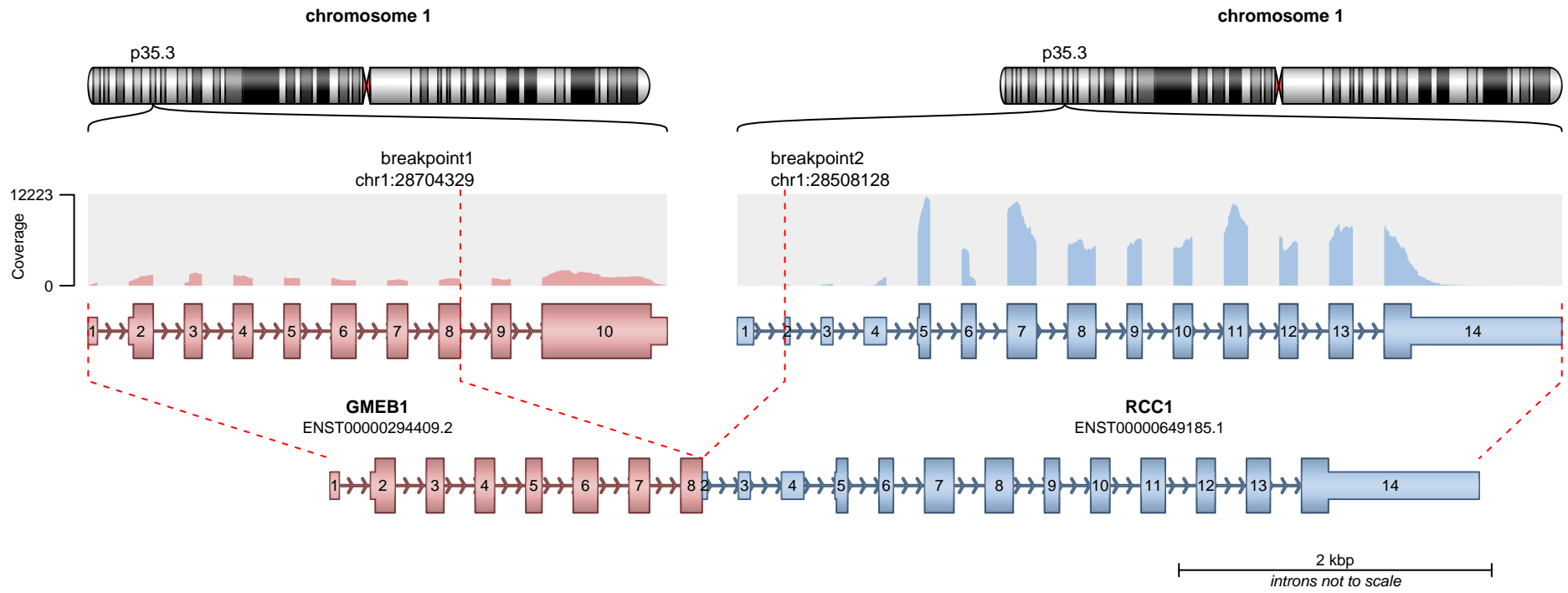

RETAINED PROTEIN DOMAINS
reading frame unclear

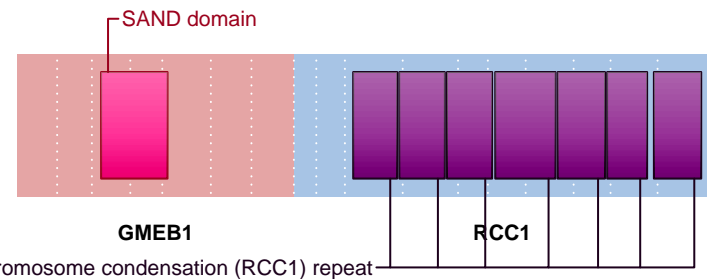

SUPPORTING READ COUNT

Split reads = 14
Discordant mates = 2

- translocation
- duplication
- deletion
- inversion

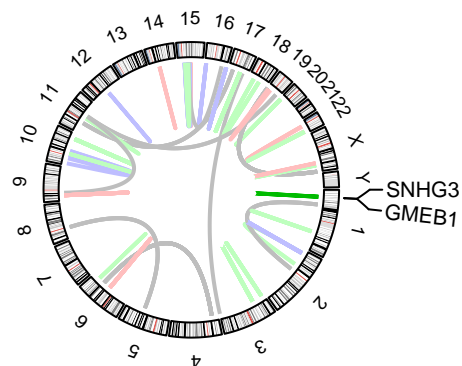
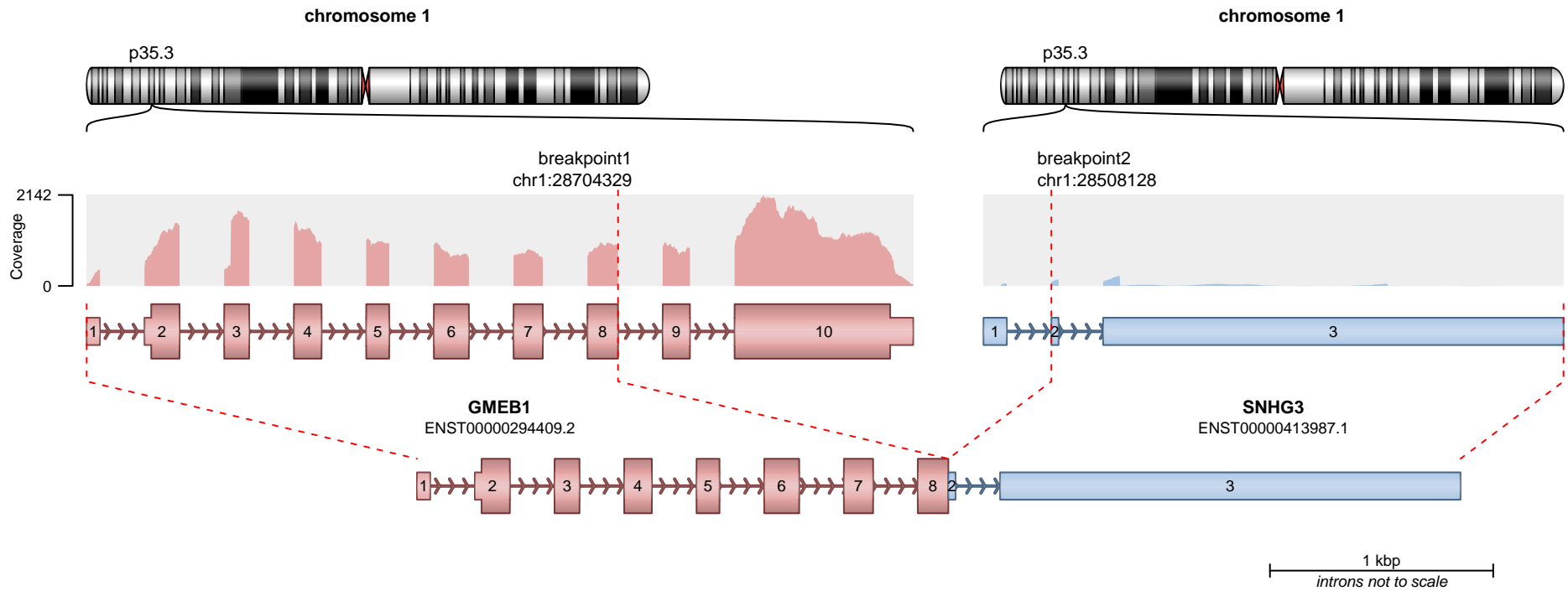

RETAINED PROTEIN DOMAINS
reading frame unclear

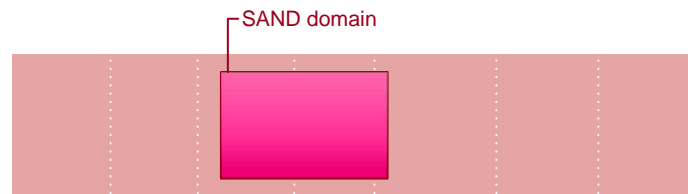

SUPPORTING READ COUNT

Split reads = 14
Discordant mates = 2

- translocation
- duplication
- deletion
- inversion

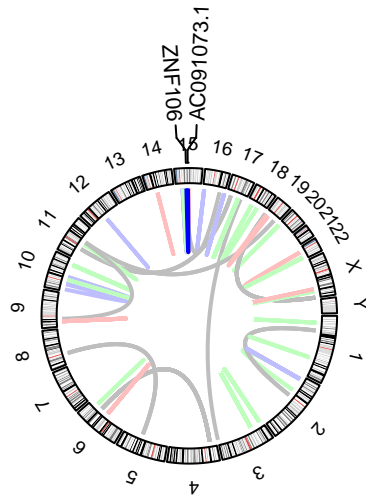
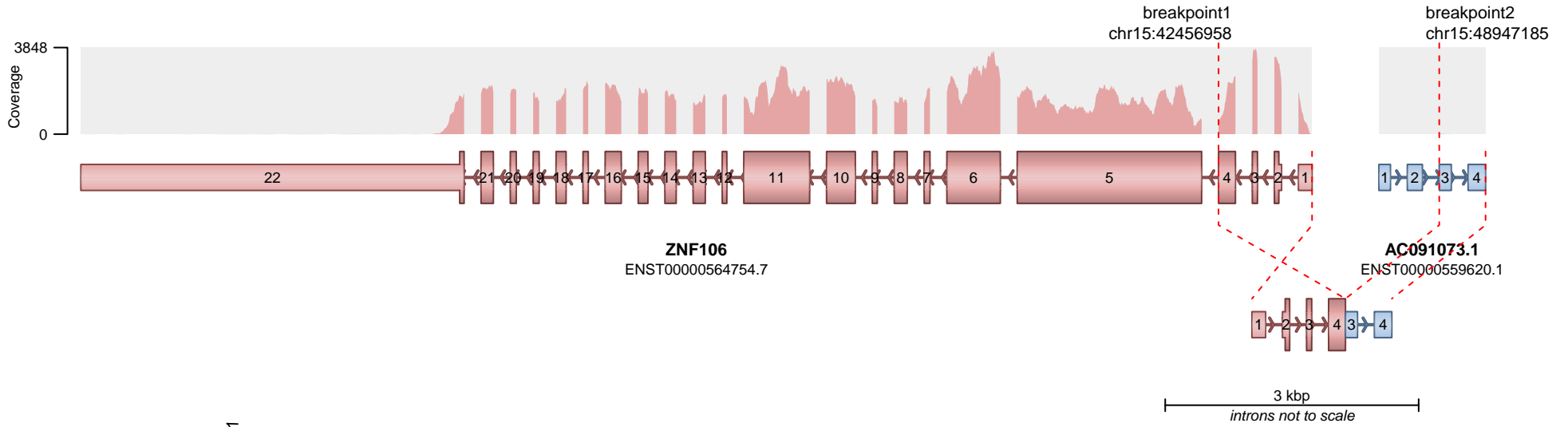
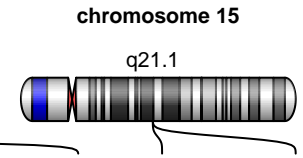
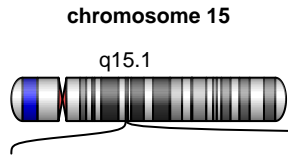

— translocation — deletion
— duplication — inversion

No protein domains retained in fusion.

SUPPORTING READ COUNT

Split reads = 14
Discordant mates = 2

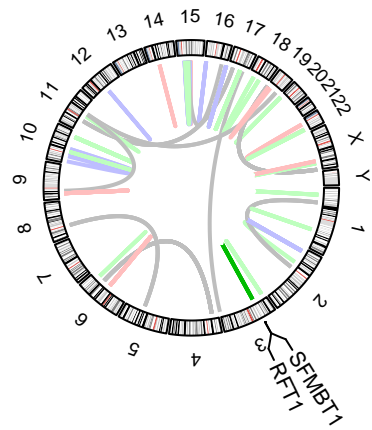
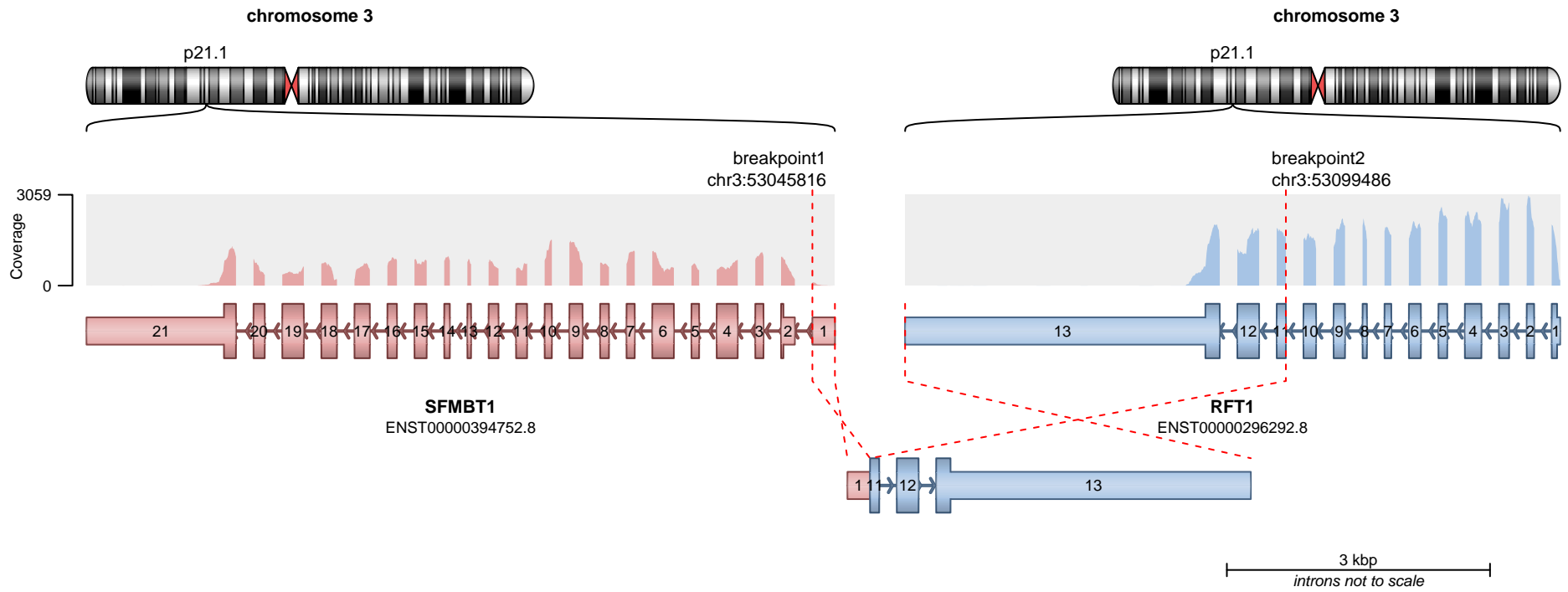

— translocation — deletion
— duplication — inversion

RETAINED PROTEIN DOMAINS
reading frame unclear

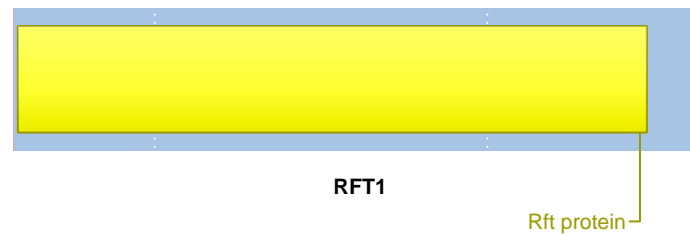

SUPPORTING READ COUNT

Split reads = 11
Discordant mates = 3

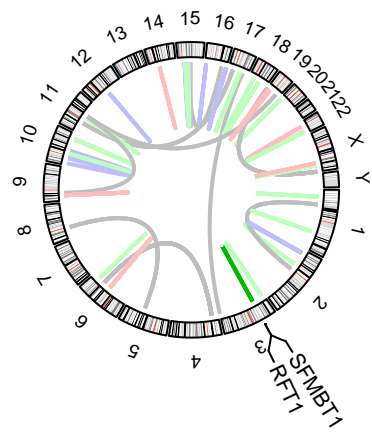
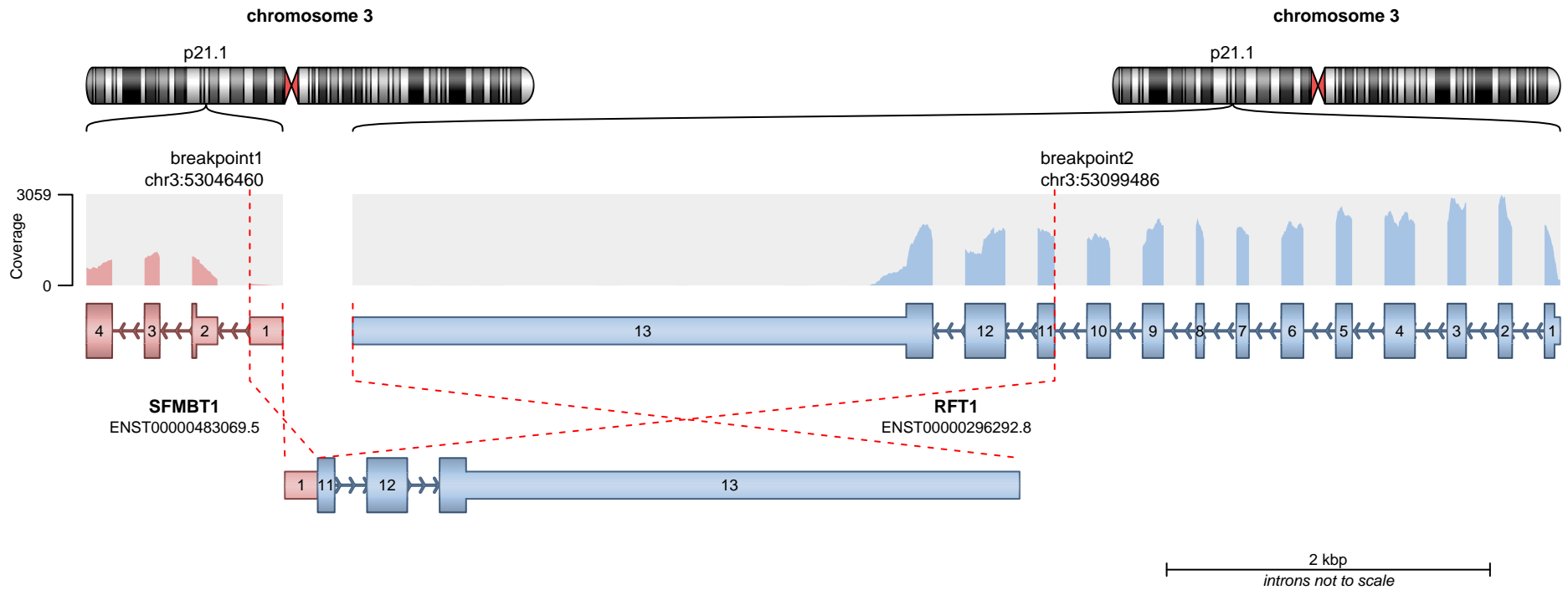

RETAINED PROTEIN DOMAINS
reading frame unclear

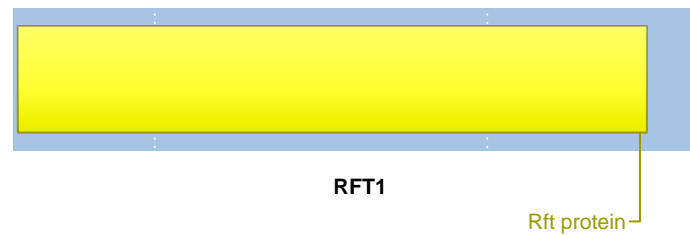

SUPPORTING READ COUNT

Split reads = 7
Discordant mates = 3

— translocation — deletion
— duplication — inversion

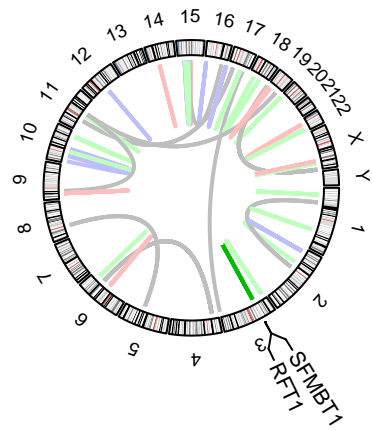
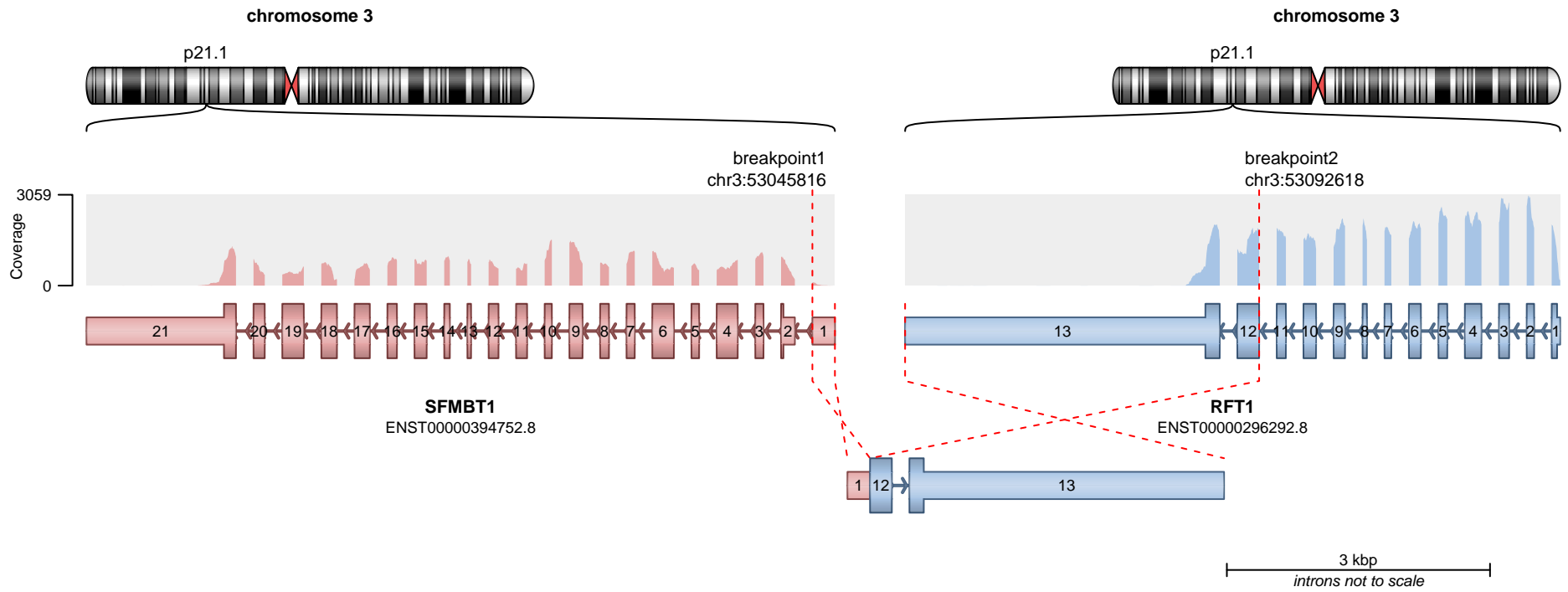

— translocation — deletion
— duplication — inversion

RETAINED PROTEIN DOMAINS
reading frame unclear

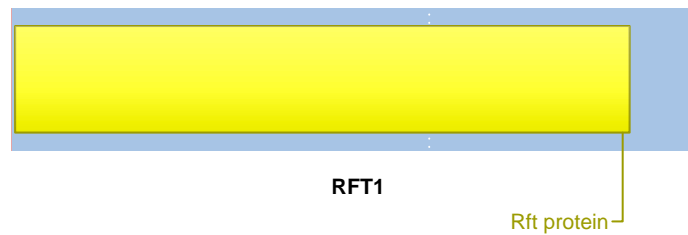

SUPPORTING READ COUNT

Split reads = 2
Discordant mates = 0

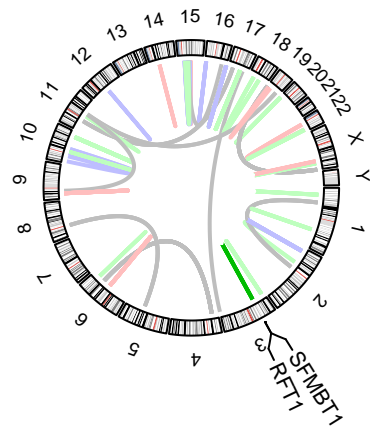
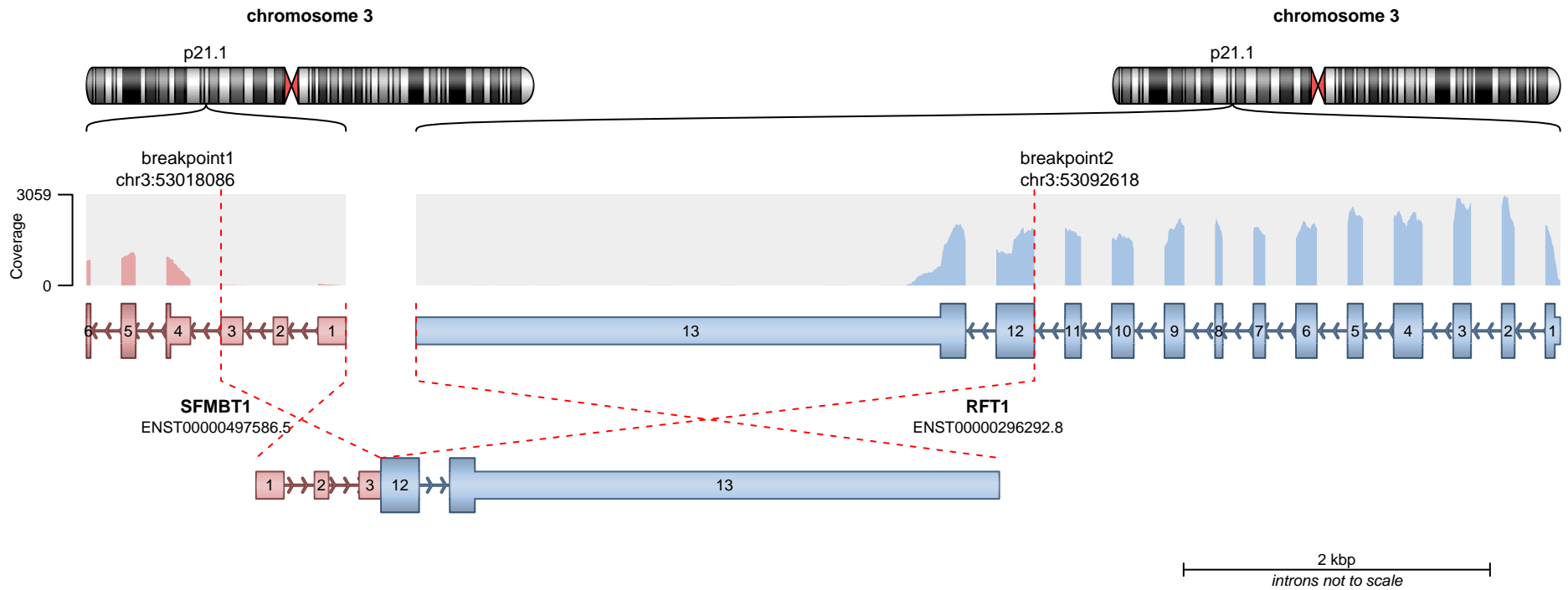

RETAINED PROTEIN DOMAINS
reading frame unclear

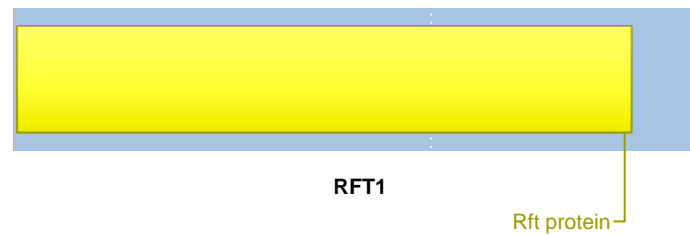

SUPPORTING READ COUNT

Split reads = 2
Discordant mates = 0

— translocation — deletion
— duplication — inversion

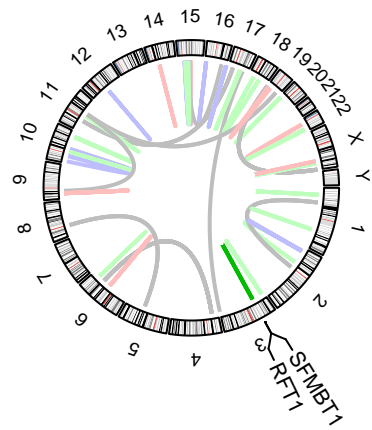
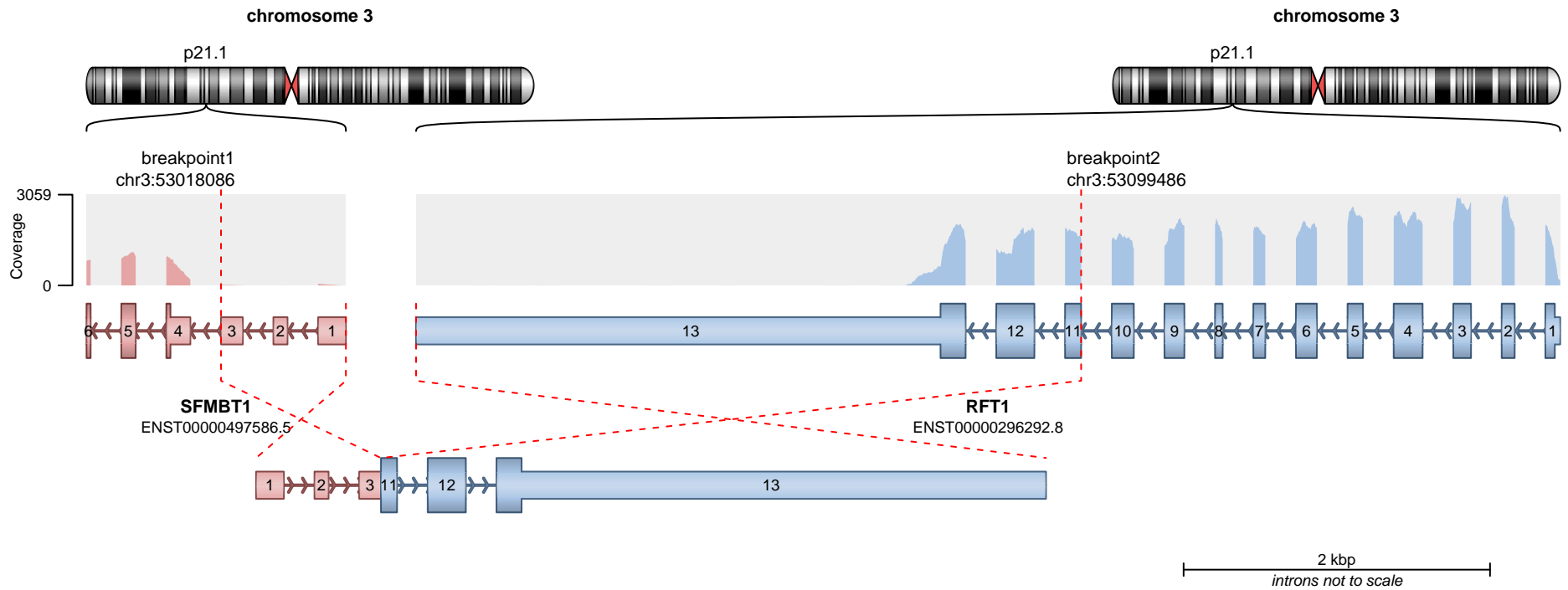

— translocation — deletion
— duplication — inversion

RETAINED PROTEIN DOMAINS
reading frame unclear

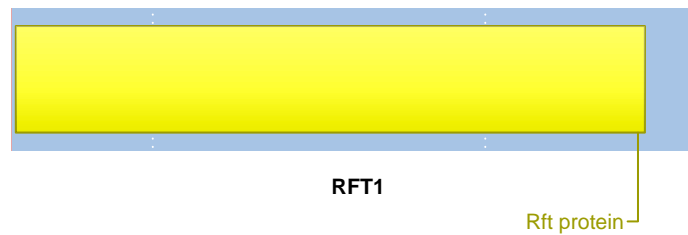

SUPPORTING READ COUNT

Split reads = 1
Discordant mates = 3

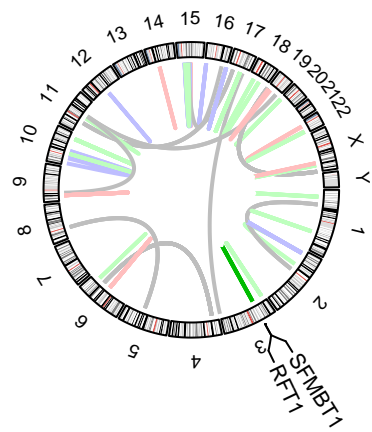
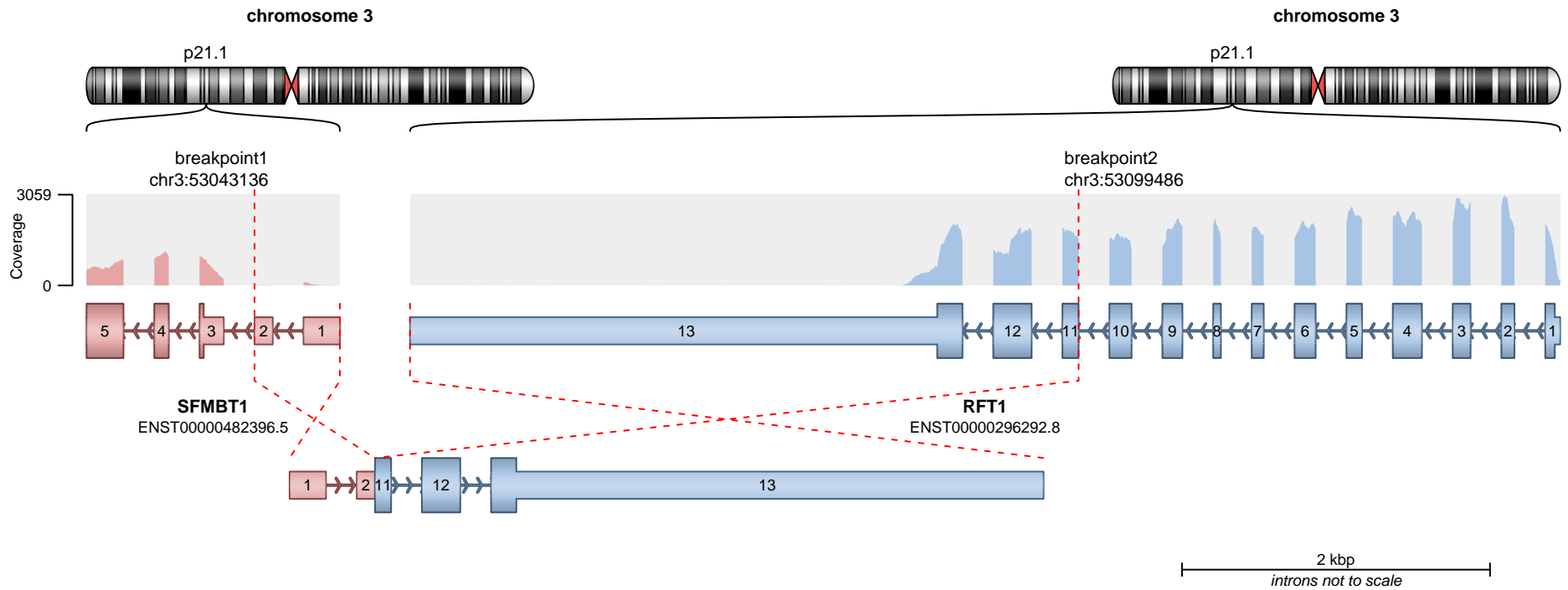

RETAINED PROTEIN DOMAINS
reading frame unclear

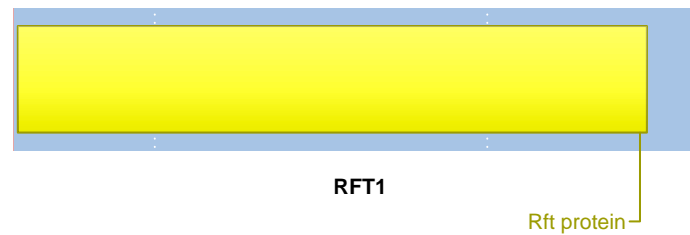

SUPPORTING READ COUNT

Split reads = 1
Discordant mates = 3

— translocation — deletion
— duplication — inversion

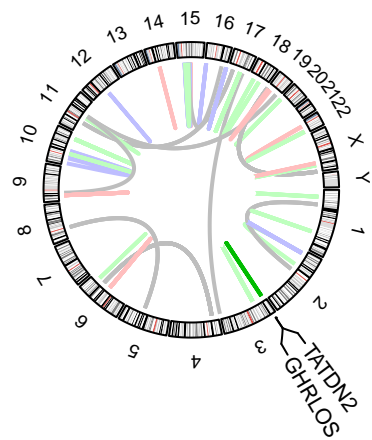
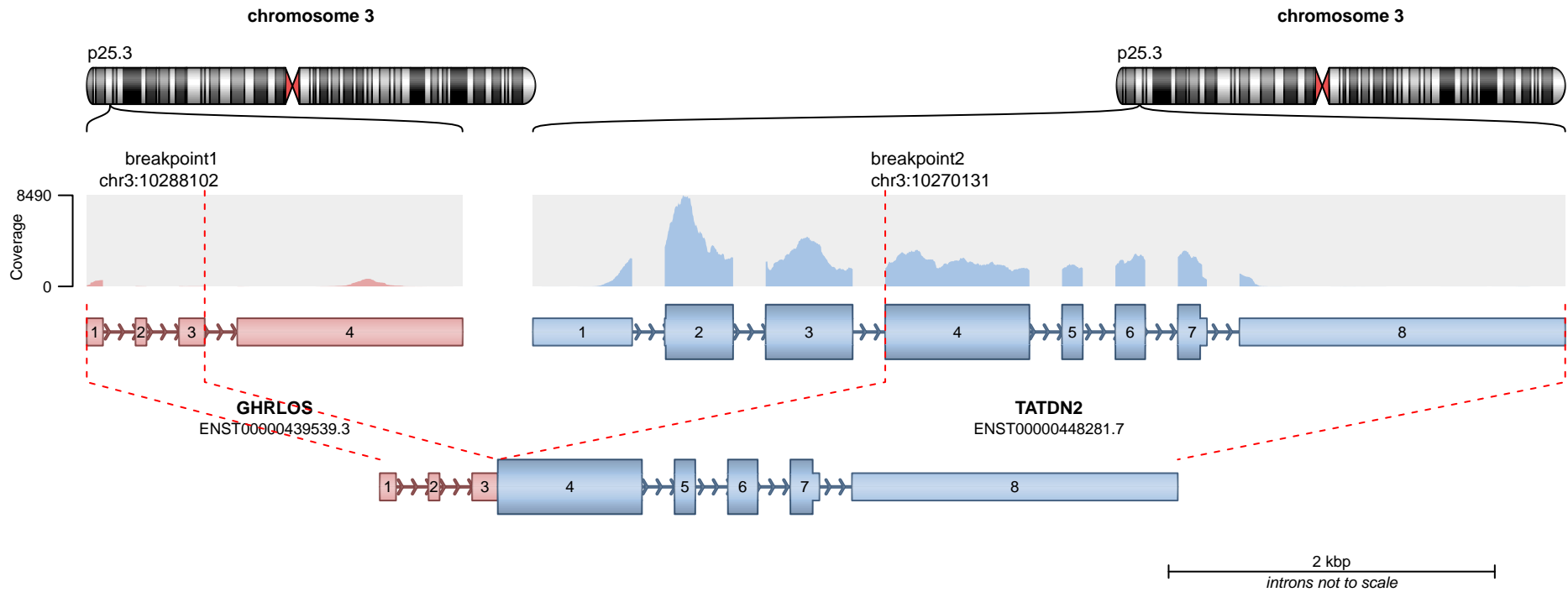

RETAINED PROTEIN DOMAINS
reading frame unclear

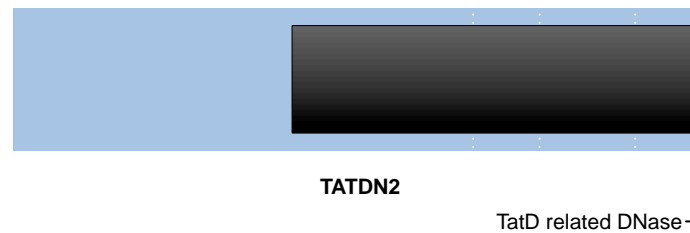

SUPPORTING READ COUNT

Split reads = 10
Discordant mates = 0

— translocation — deletion
— duplication — inversion

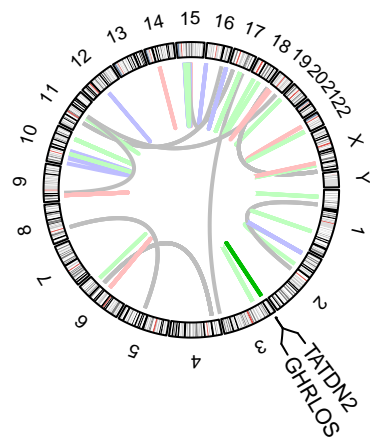
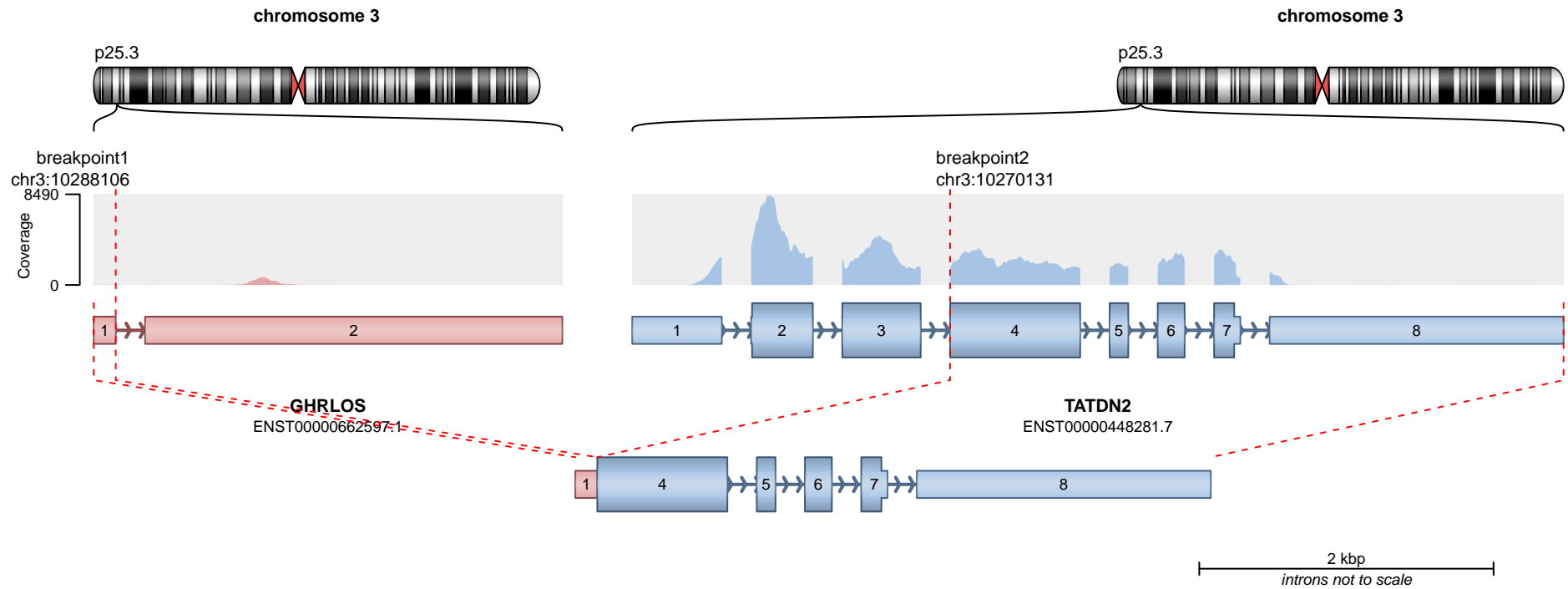

— translocation — deletion
— duplication — inversion

RETAINED PROTEIN DOMAINS
reading frame unclear

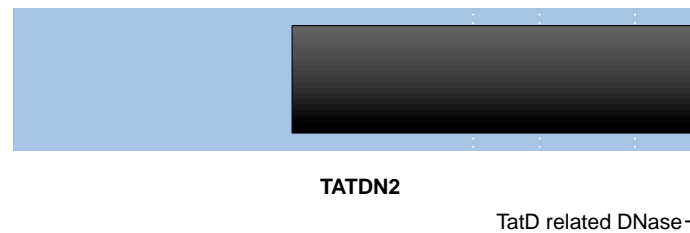

SUPPORTING READ COUNT

Split reads = 6
Discordant mates = 0

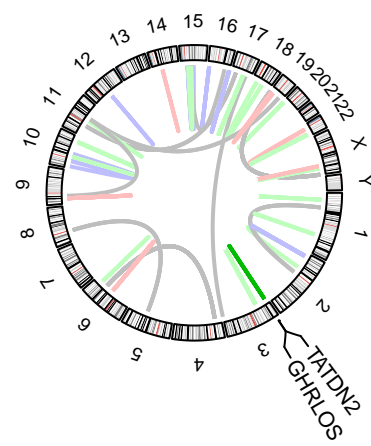
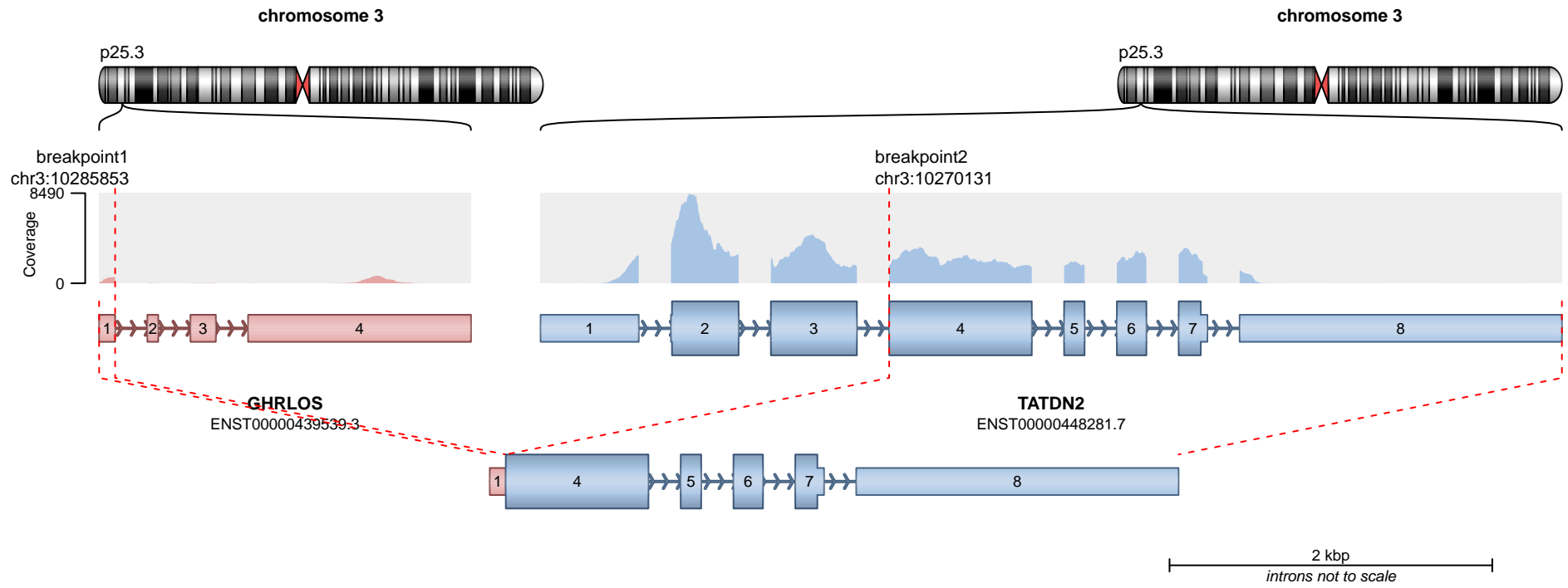

— translocation — deletion
— duplication — inversion

RETAINED PROTEIN DOMAINS
reading frame unclear

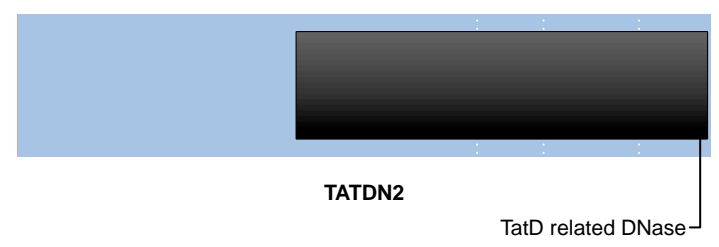

SUPPORTING READ COUNT

Split reads = 4
Discordant mates = 0

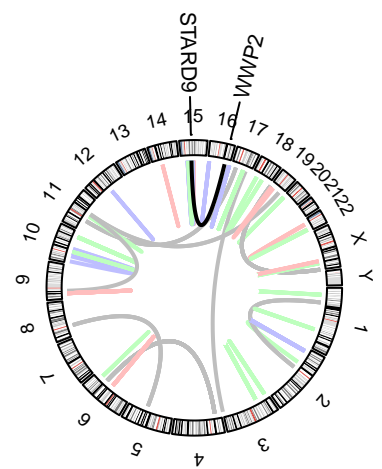
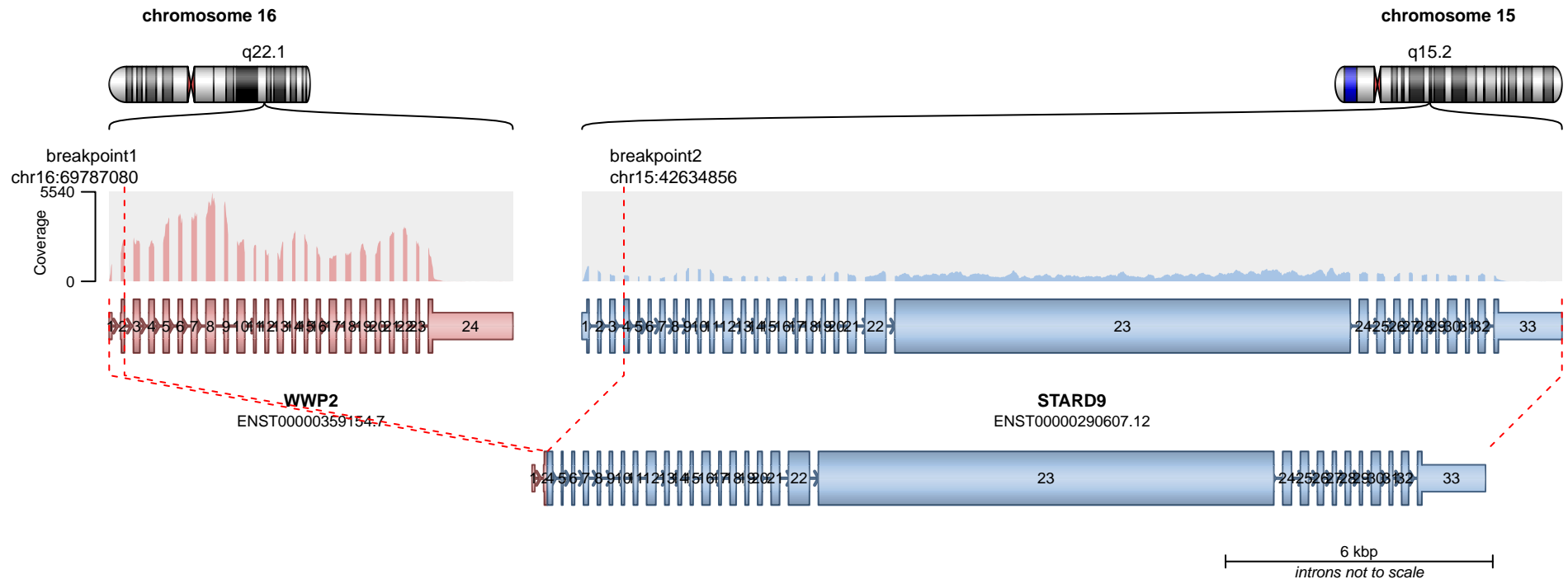

RETAINED PROTEIN DOMAINS
reading frame unclear

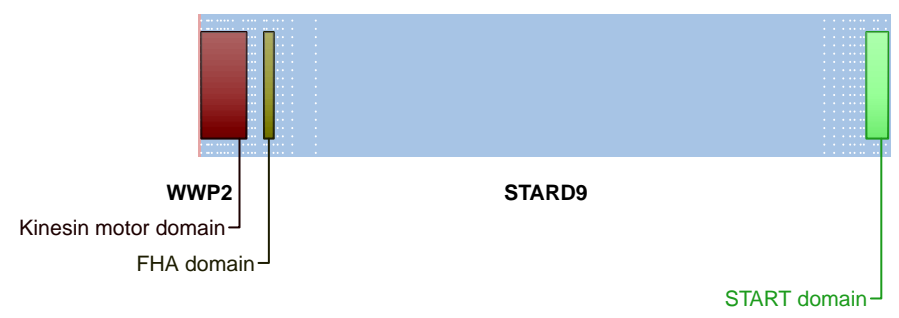

SUPPORTING READ COUNT

Split reads = 10
Discordant mates = 0

— translocation — deletion
— duplication — inversion

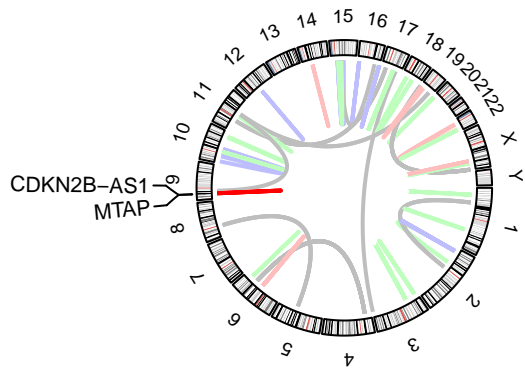
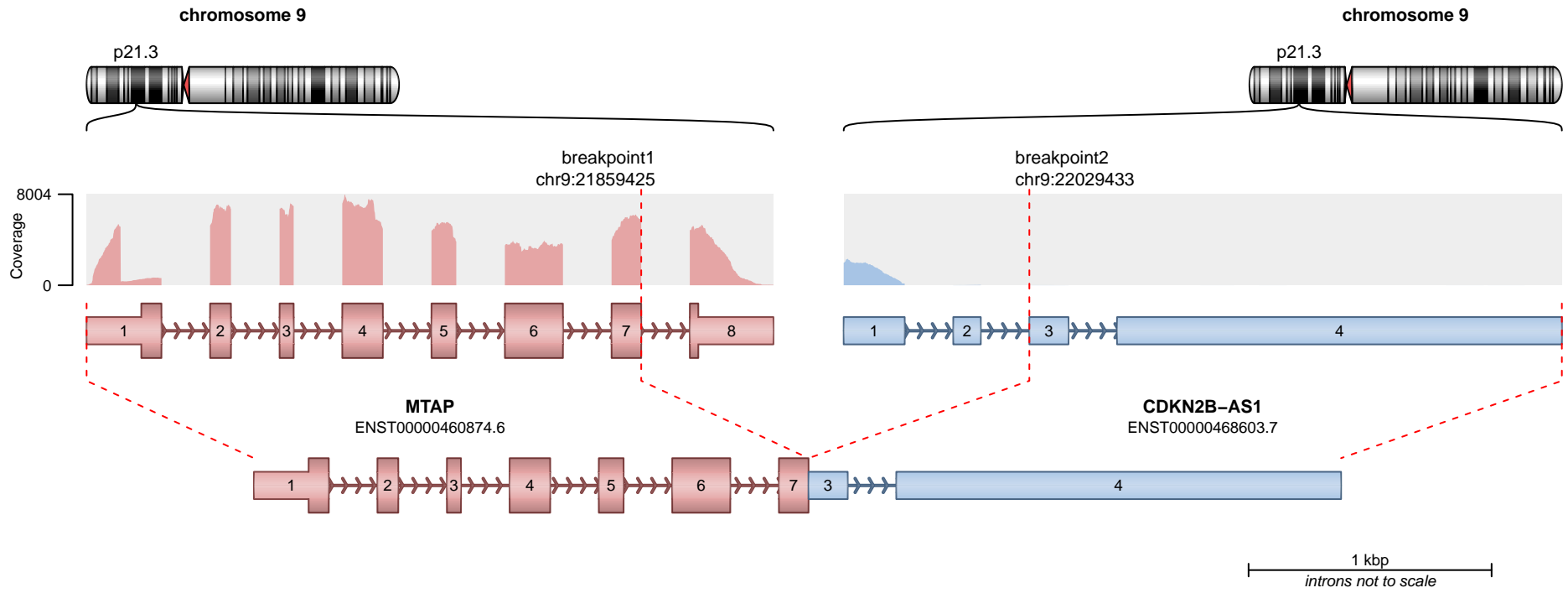

RETAINED PROTEIN DOMAINS
reading frame unclear

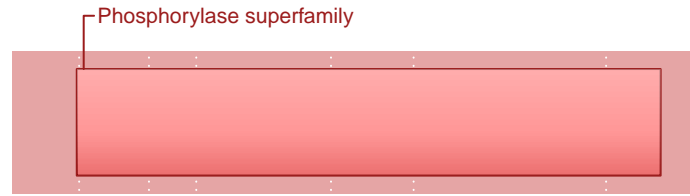

MTAP

SUPPORTING READ COUNT

Split reads = 6
Discordant mates = 1

- translocation
- duplication
- deletion
- inversion

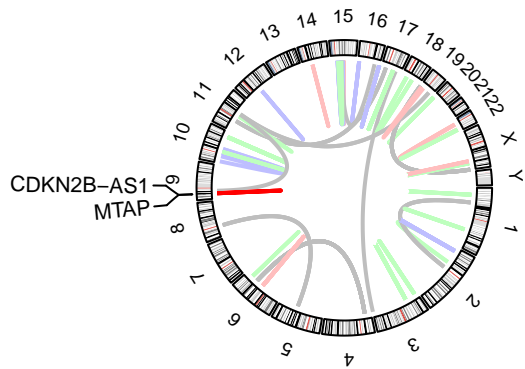
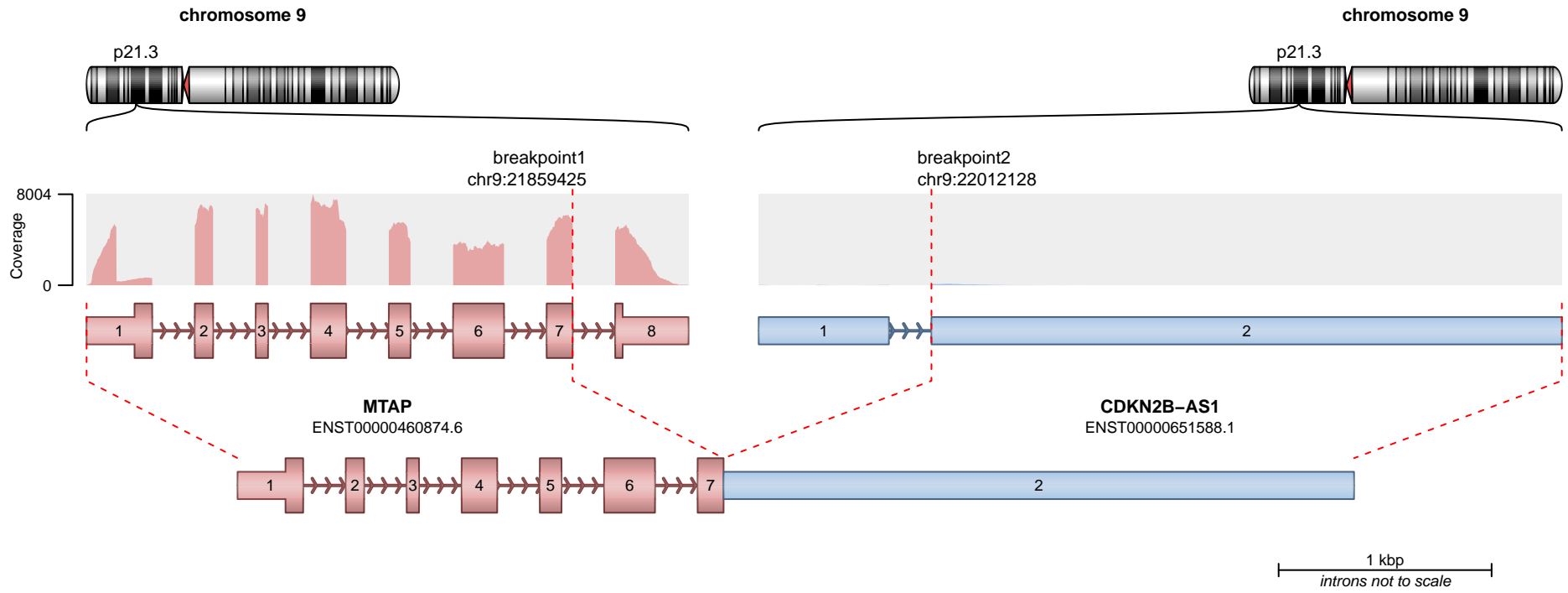

RETAINED PROTEIN DOMAINS
reading frame unclear

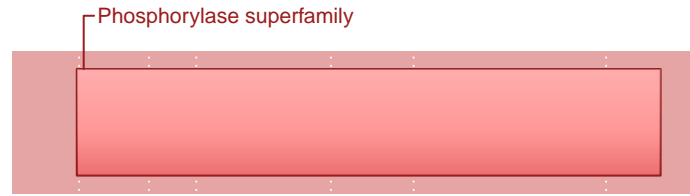

MTAP

SUPPORTING READ COUNT

Split reads = 3
Discordant mates = 1

— translocation — deletion
— duplication — inversion

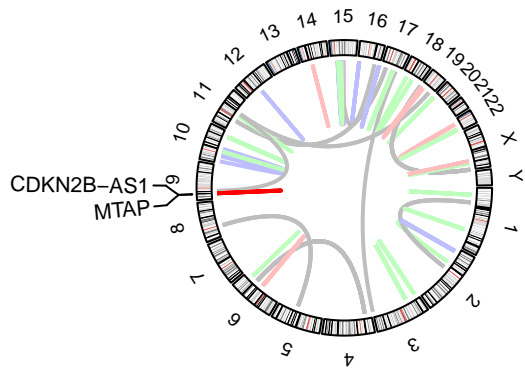
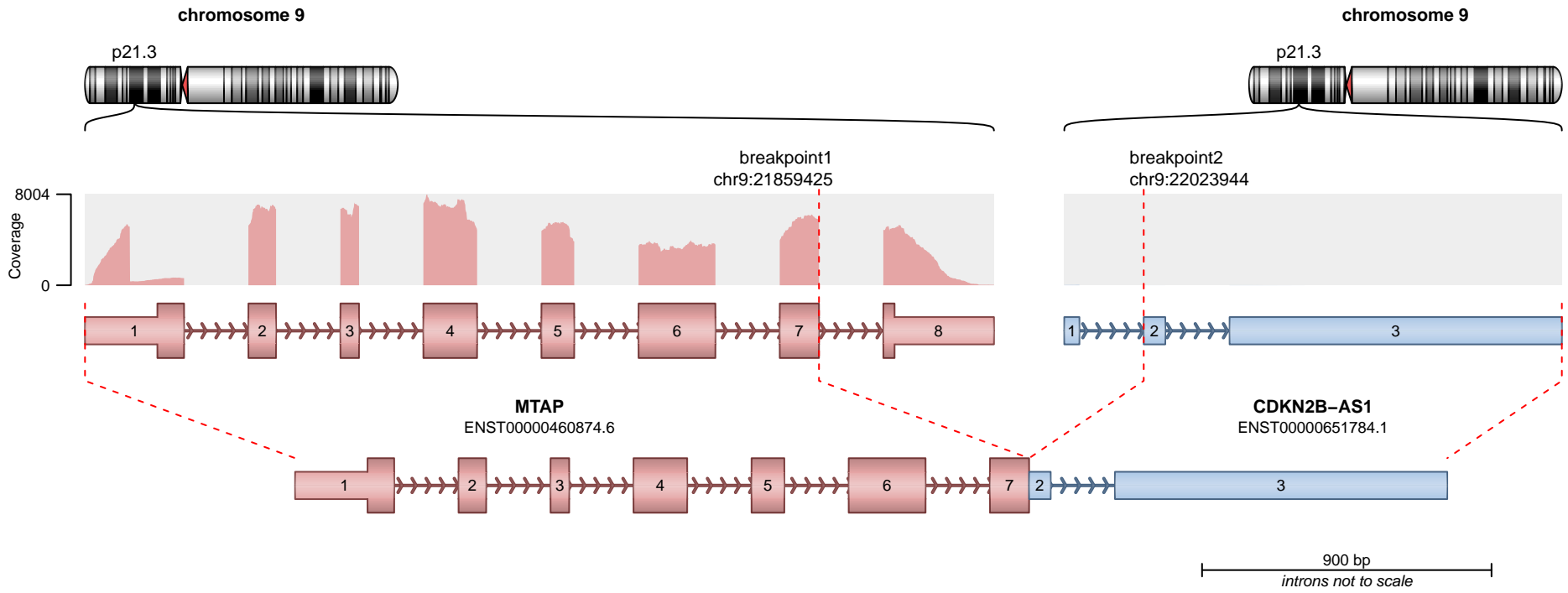

RETAINED PROTEIN DOMAINS
reading frame unclear

Phosphorylase superfamily



MTAP

SUPPORTING READ COUNT

Split reads = 2
Discordant mates = 1

- translocation
- duplication
- deletion
- inversion

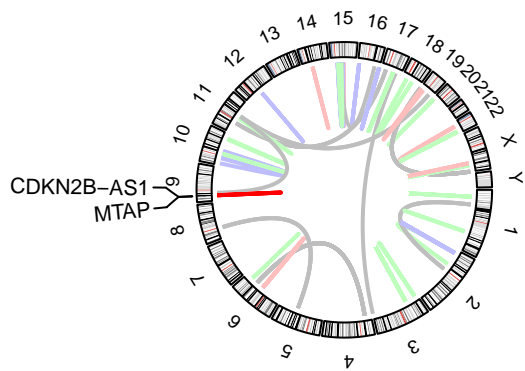
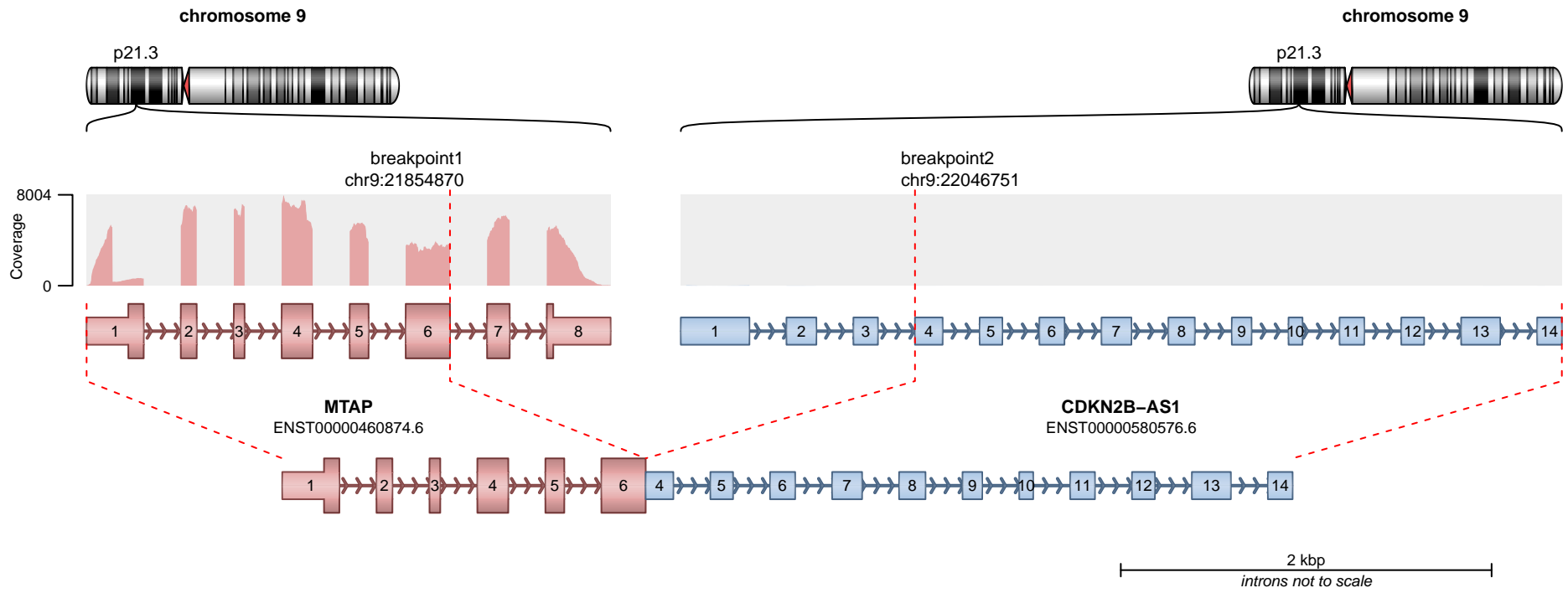

— translocation — deletion
 — duplication — inversion

RETAINED PROTEIN DOMAINS
reading frame unclear

Phosphorylase superfamily



MTAP

SUPPORTING READ COUNT

Split reads = 2
Discordant mates = 0

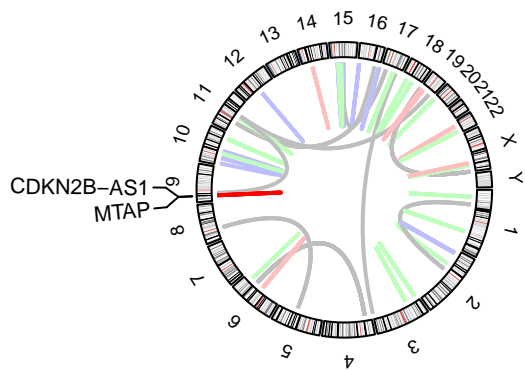
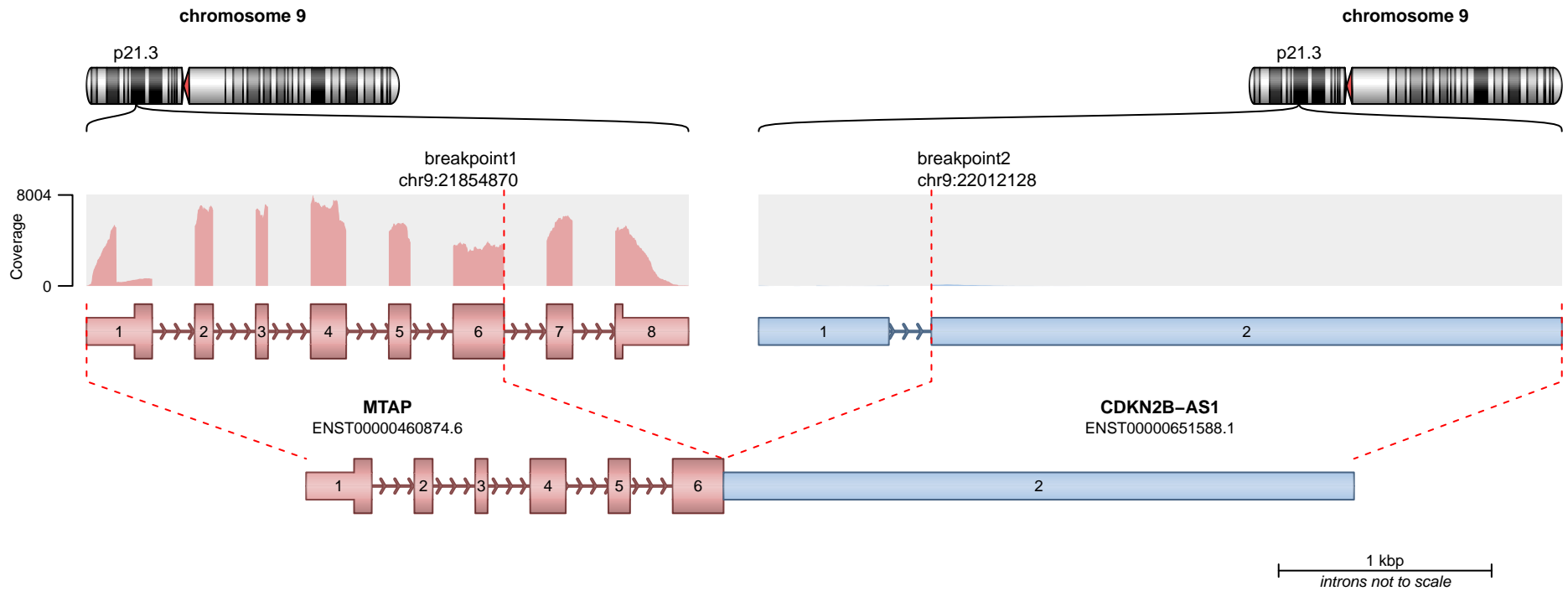

RETAINED PROTEIN DOMAINS
reading frame unclear

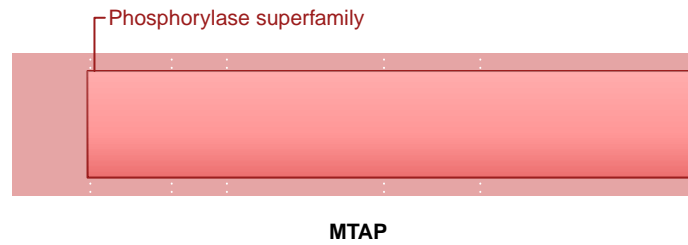

SUPPORTING READ COUNT

Split reads = 1
Discordant mates = 1

- translocation
- duplication
- deletion
- inversion

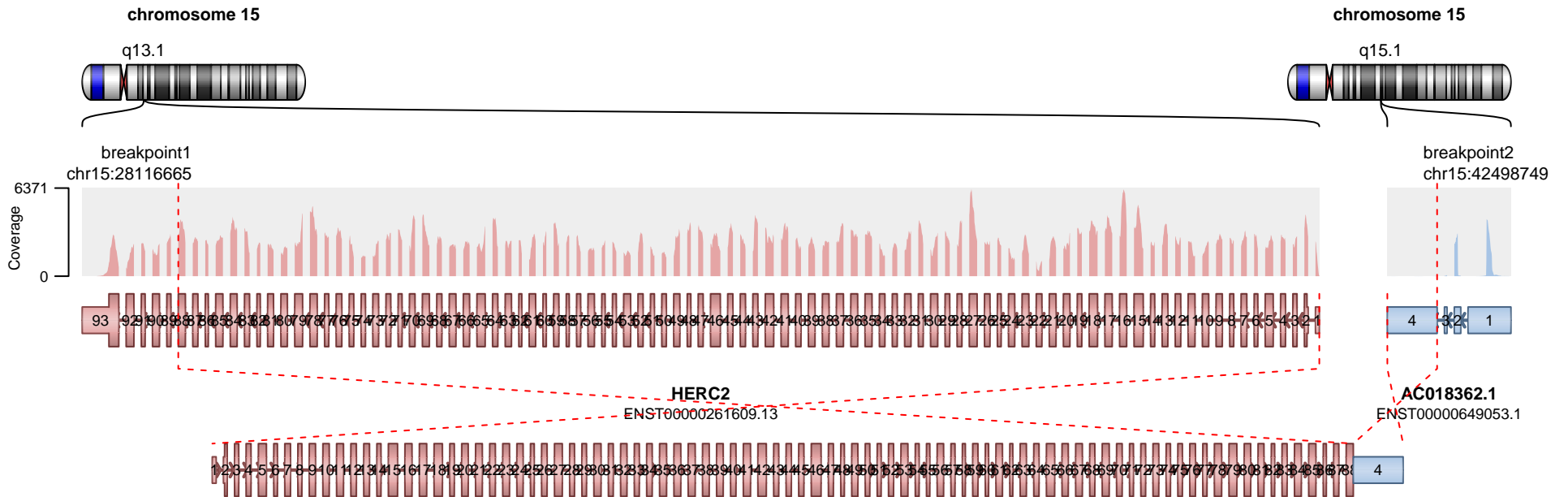

RETAINED PROTEIN DOMAINS
reading frame unclear

7 kbp
introns not to scale

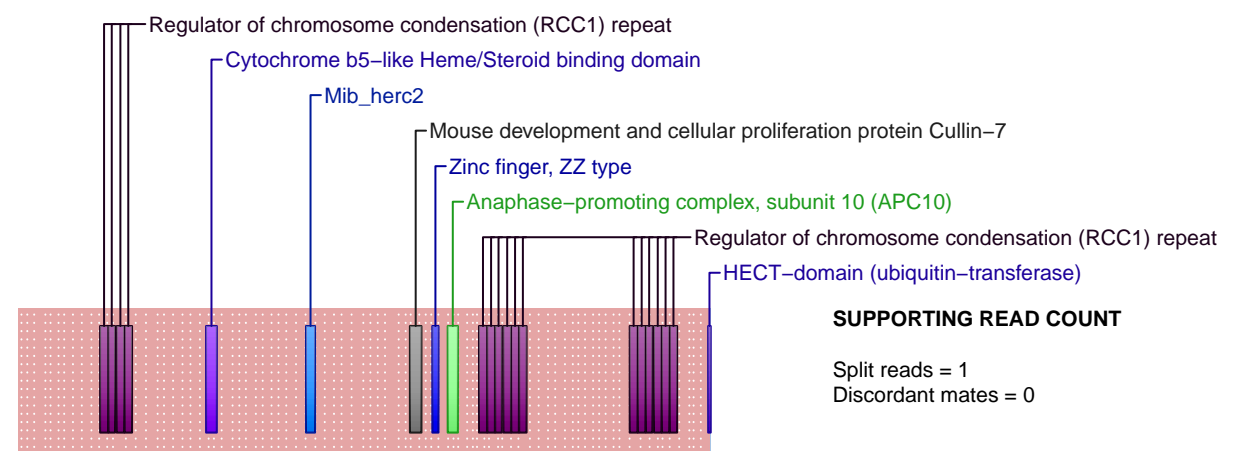
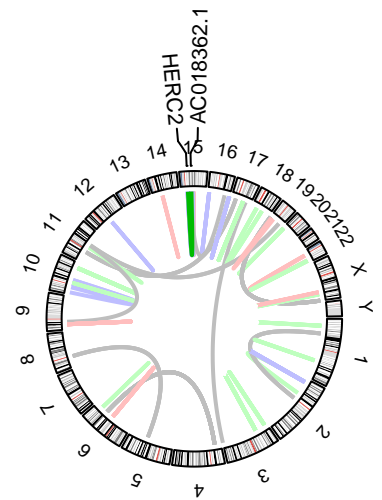

SUPPORTING READ COUNT

Split reads = 1
Discordant mates = 0

HERC2

— translocation — deletion
— duplication — inversion