

RETAINED PROTEIN DOMAINS
reading frame unclear



SUPPORTING READ COUNT

Split reads = 4544
Discordant mates = 147

- translocation
- duplication
- deletion
- inversion

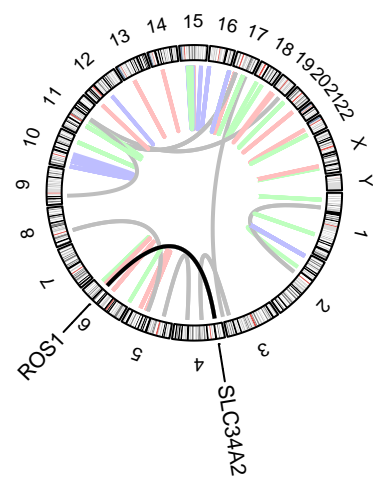
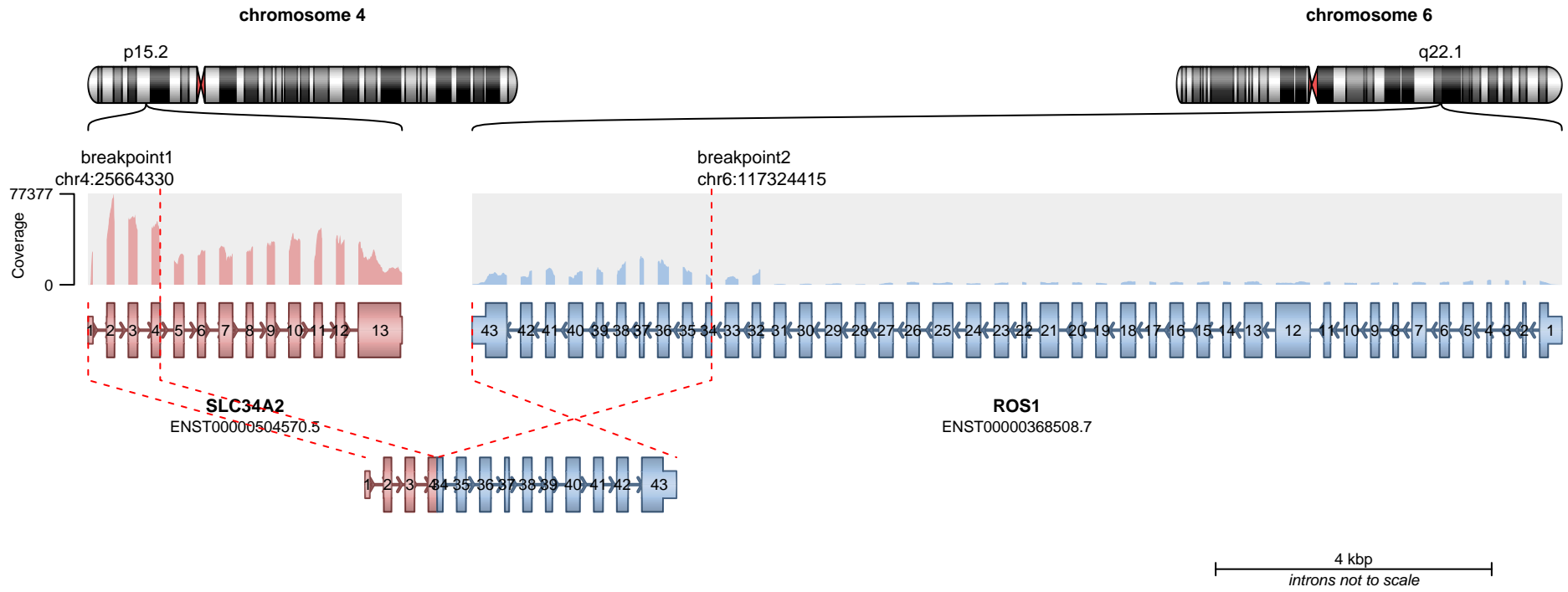

RETAINED PROTEIN DOMAINS
reading frame unclear



SUPPORTING READ COUNT

Split reads = 476
Discordant mates = 43

- translocation
- duplication
- deletion
- inversion

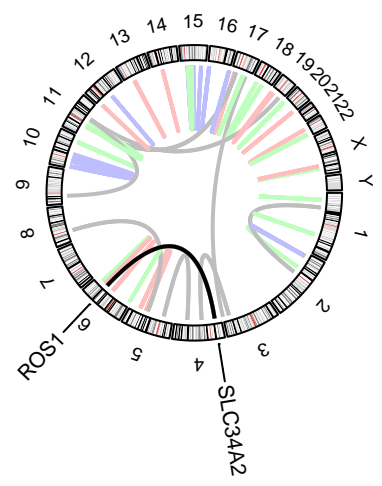
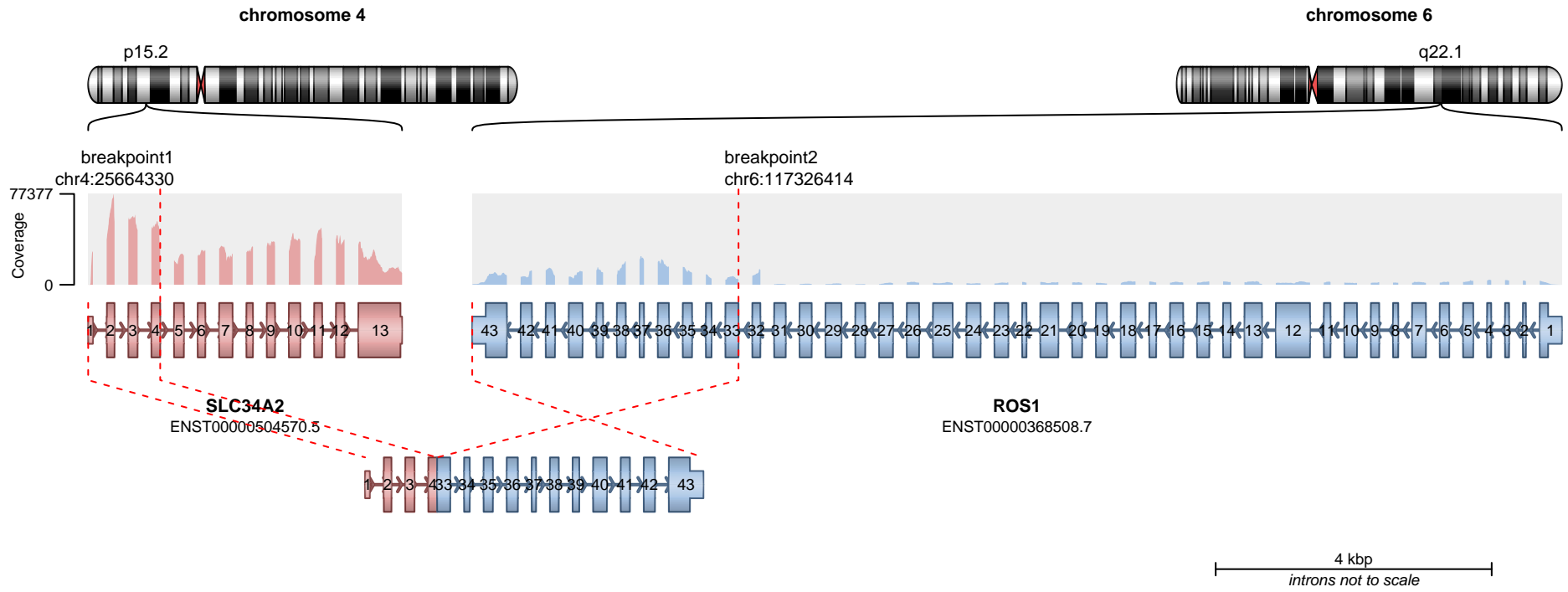

RETAINED PROTEIN DOMAINS
reading frame unclear



SUPPORTING READ COUNT

Split reads = 67
Discordant mates = 47

- translocation
- duplication
- deletion
- inversion

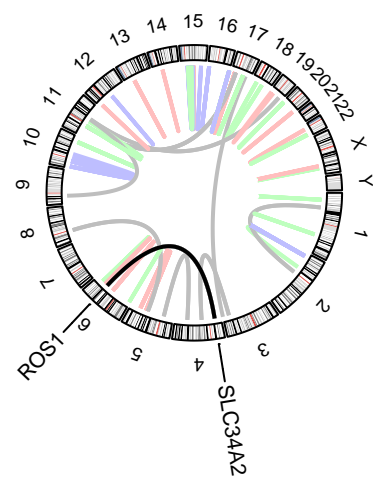
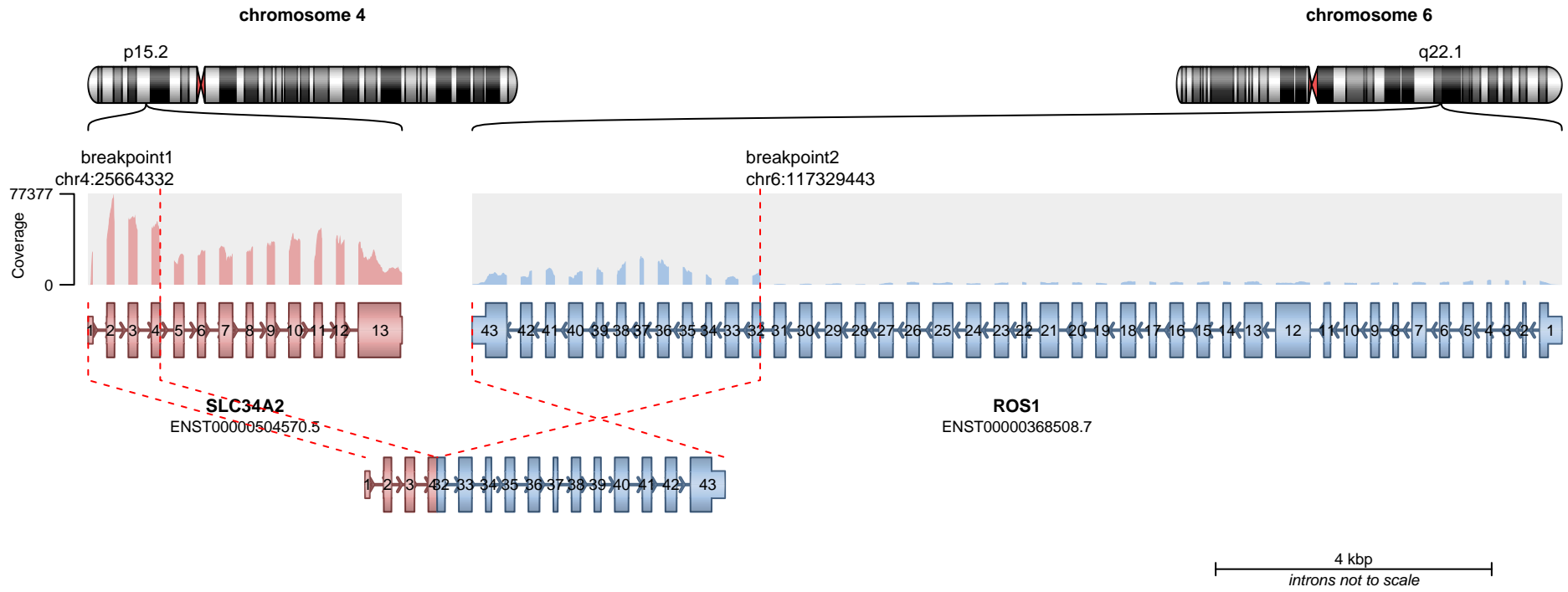

RETAINED PROTEIN DOMAINS
reading frame unclear

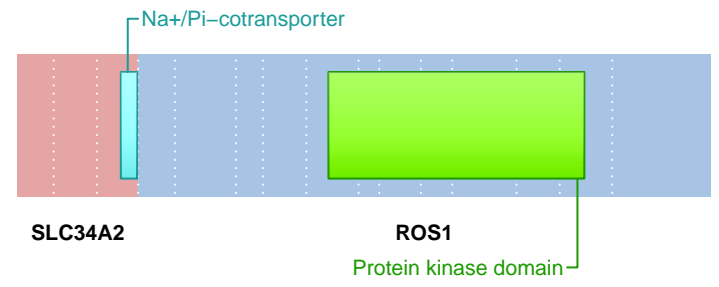

SUPPORTING READ COUNT

Split reads = 3
Discordant mates = 111

- translocation
- duplication
- deletion
- inversion

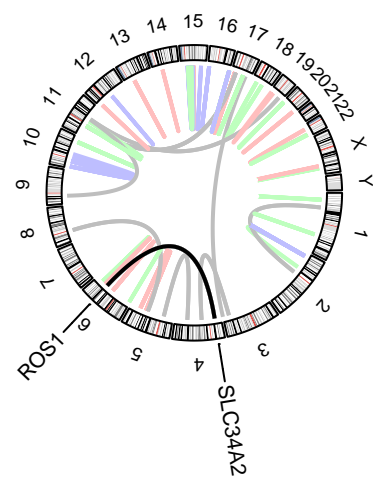
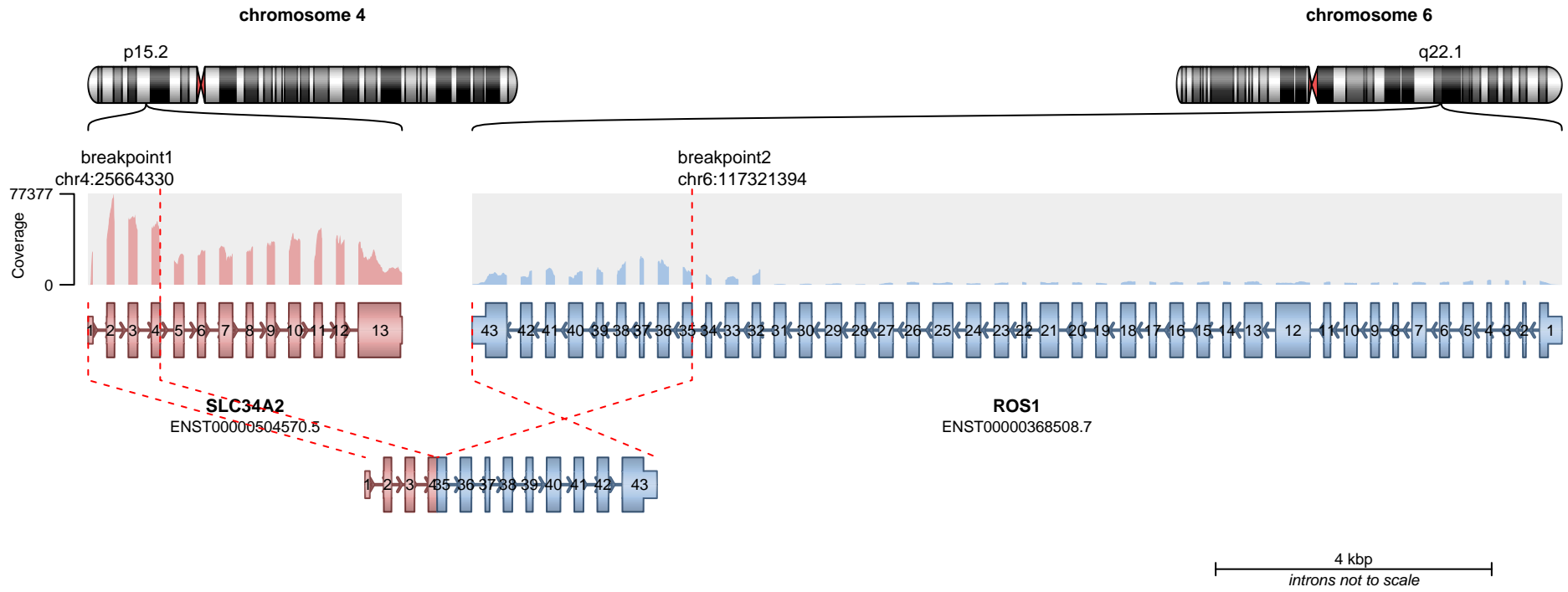

RETAINED PROTEIN DOMAINS
reading frame unclear

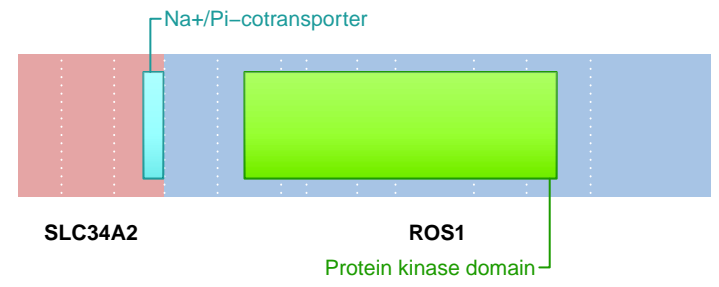

SUPPORTING READ COUNT

Split reads = 15
Discordant mates = 6

- translocation
- duplication
- deletion
- inversion

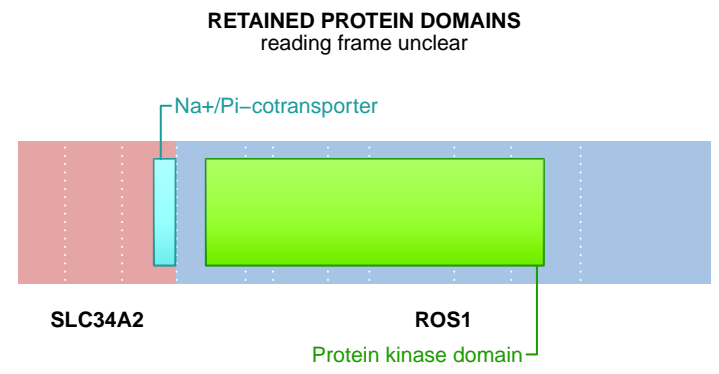
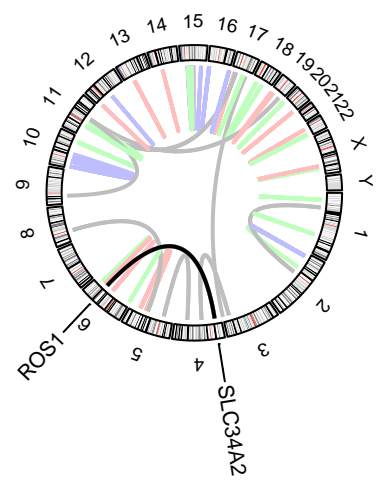
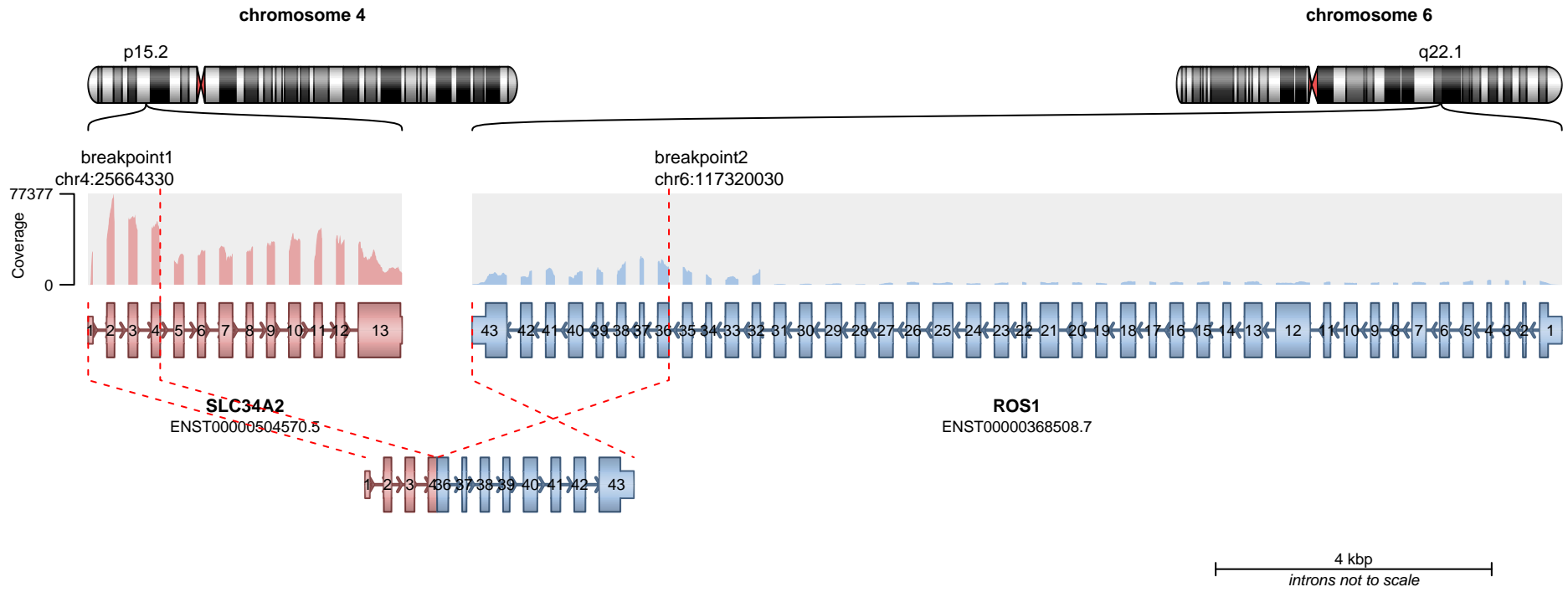

SUPPORTING READ COUNT

Split reads = 4
Discordant mates = 1

— translocation — deletion
— duplication — inversion

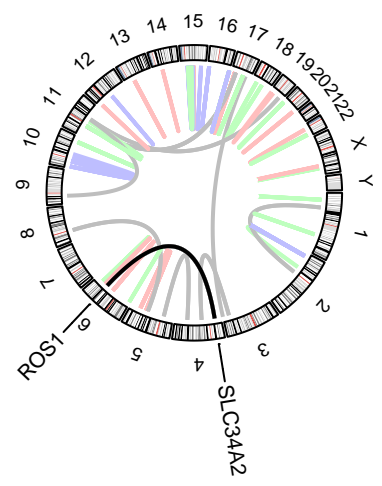
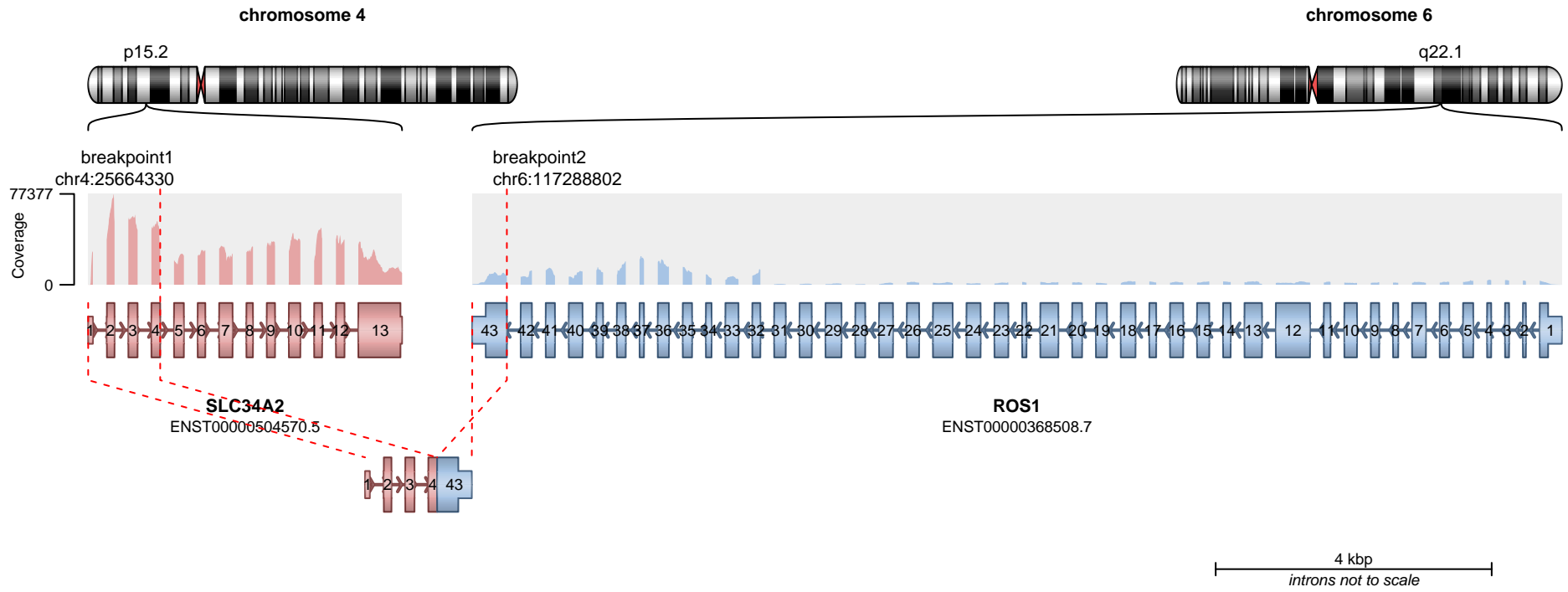

RETAINED PROTEIN DOMAINS
reading frame unclear

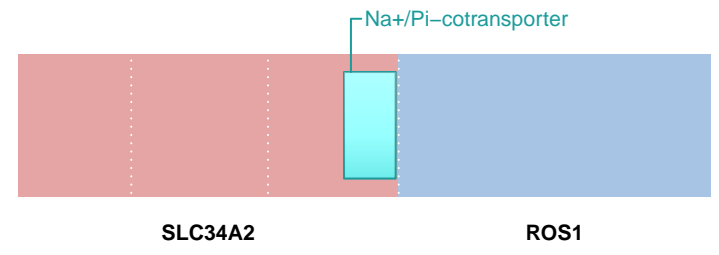

SUPPORTING READ COUNT

Split reads = 4
Discordant mates = 0

— translocation — deletion
— duplication — inversion

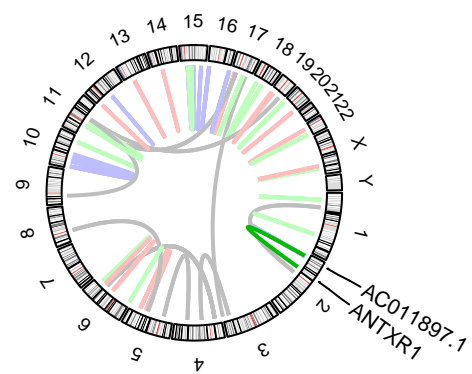
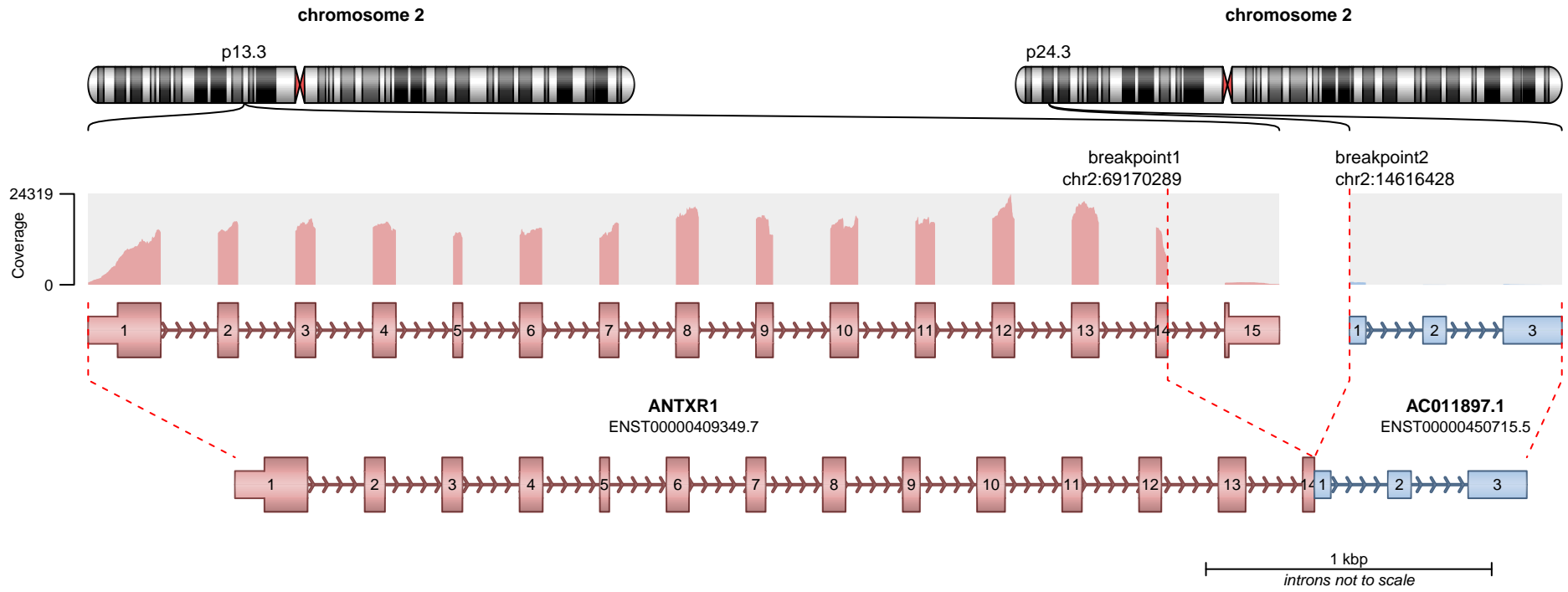

RETAINED PROTEIN DOMAINS
reading frame unclear

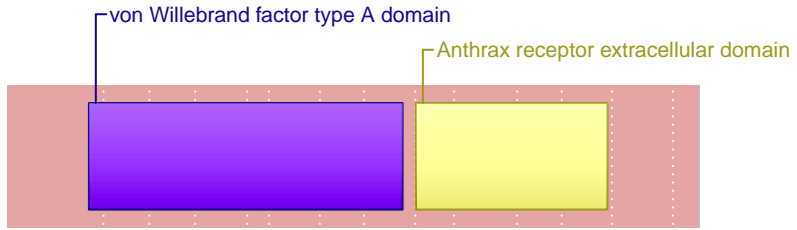

ANTXR1

SUPPORTING READ COUNT

Split reads = 632
Discordant mates = 14

- translocation
- duplication
- deletion
- inversion

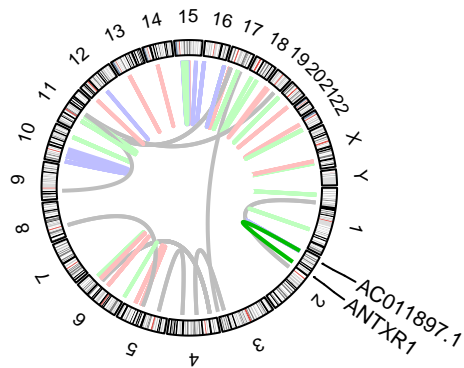
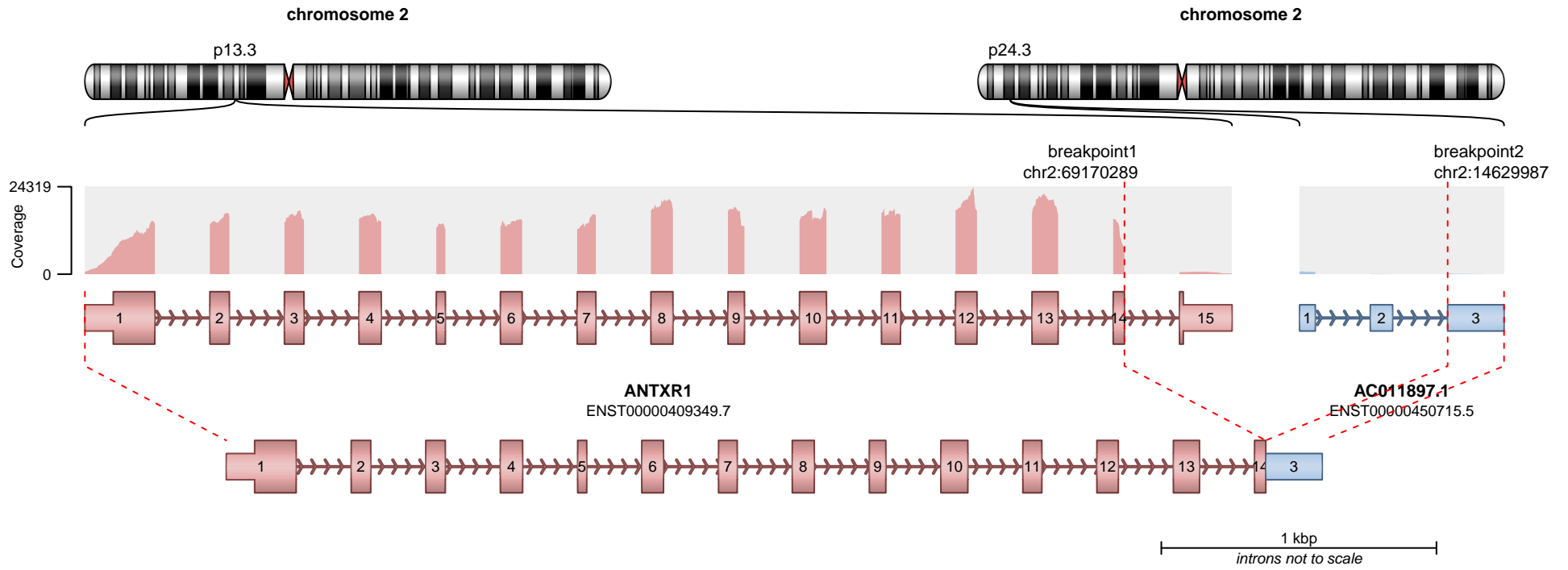

RETAINED PROTEIN DOMAINS
reading frame unclear

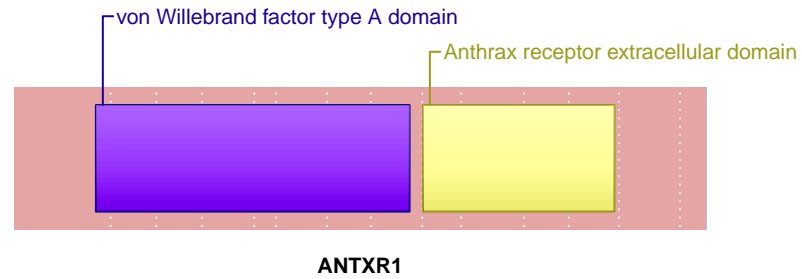

SUPPORTING READ COUNT

Split reads = 9
Discordant mates = 2

— translocation — deletion
— duplication — inversion

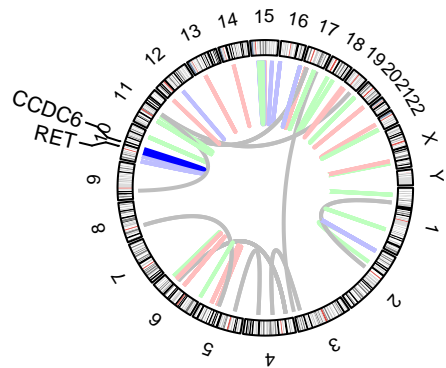
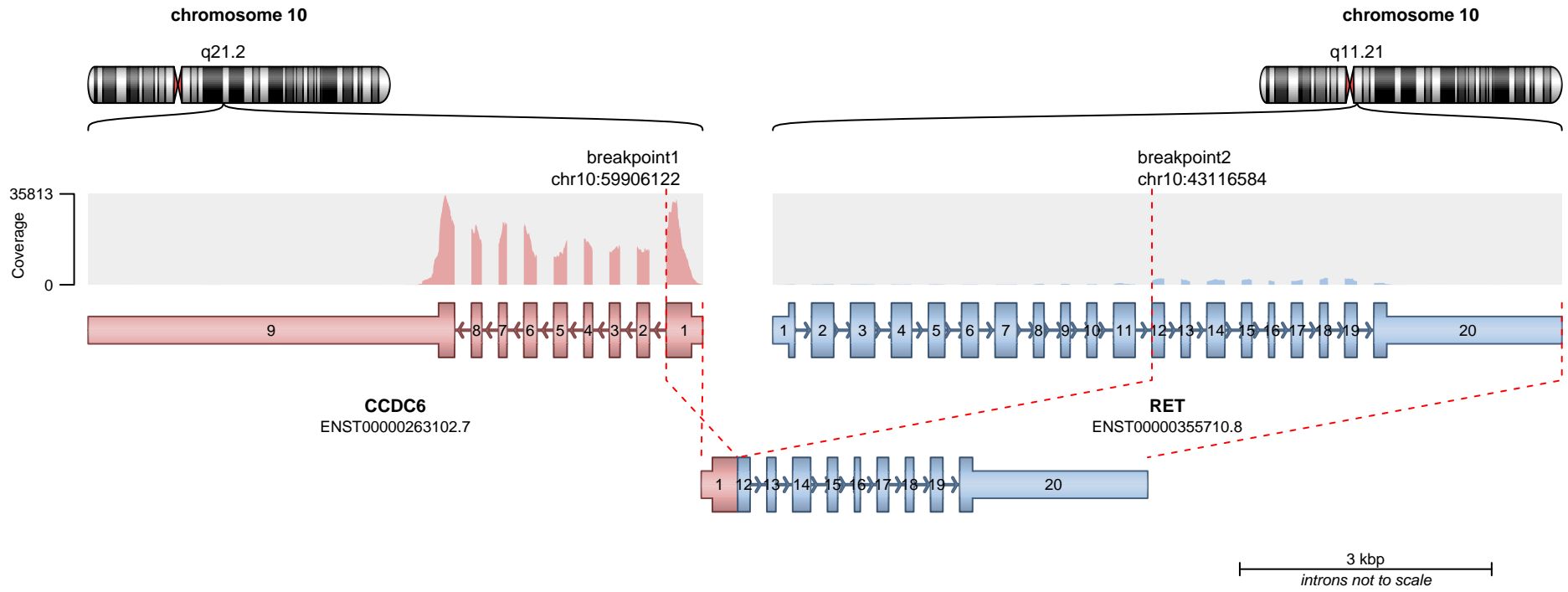

RETAINED PROTEIN DOMAINS
reading frame unclear

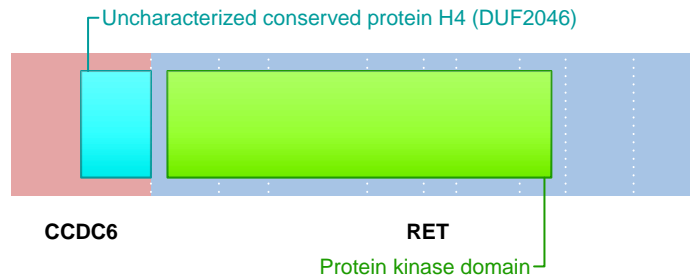

SUPPORTING READ COUNT

Split reads = 479
Discordant mates = 15

- translocation
- duplication
- deletion
- inversion

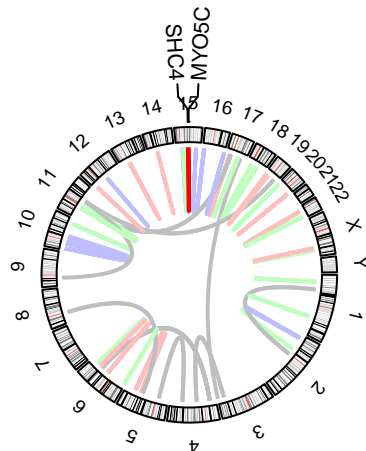
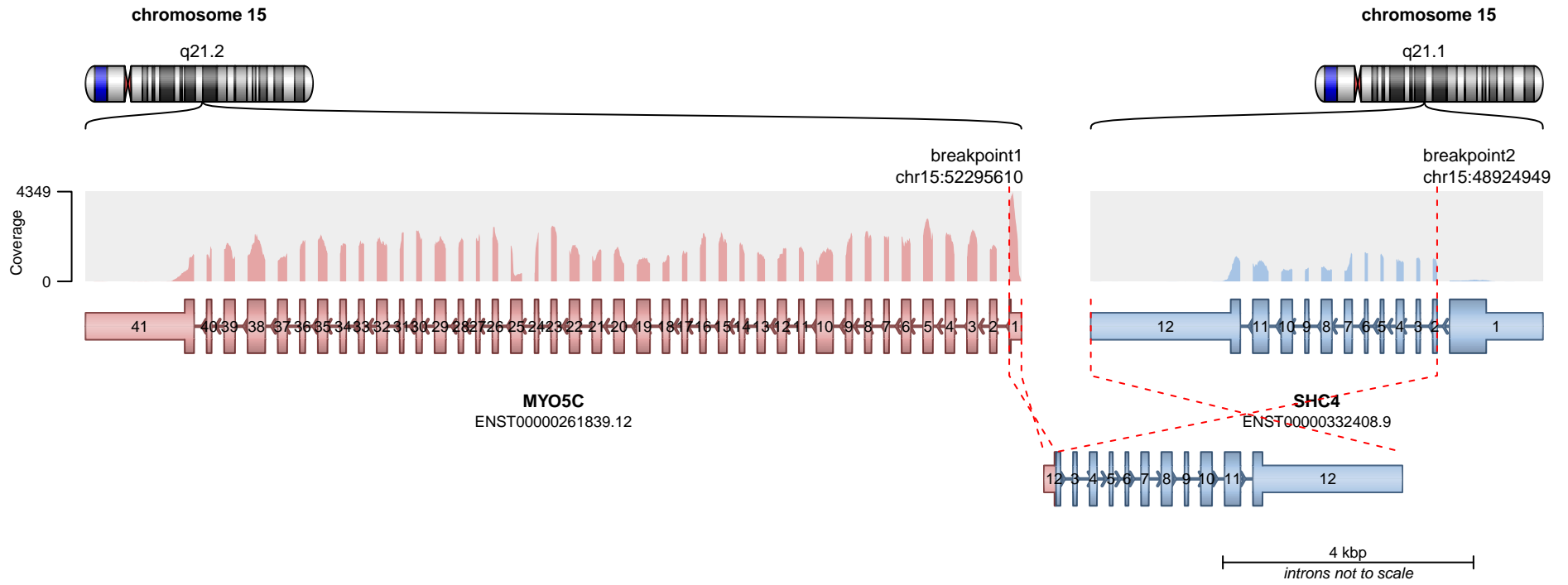

RETAINED PROTEIN DOMAINS
reading frame unclear

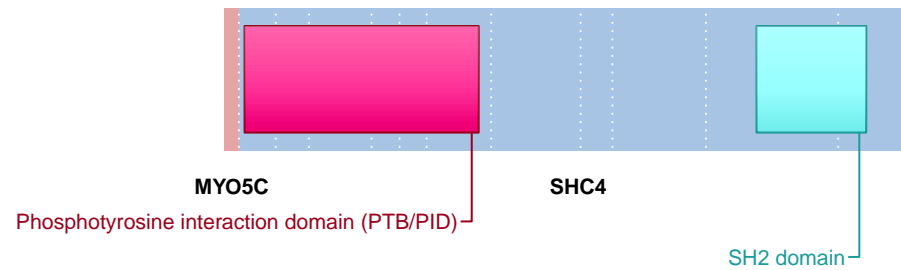

SUPPORTING READ COUNT

Split reads = 463
Discordant mates = 19

- translocation
- duplication
- deletion
- inversion

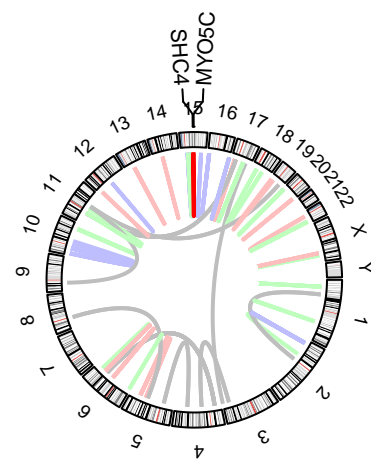
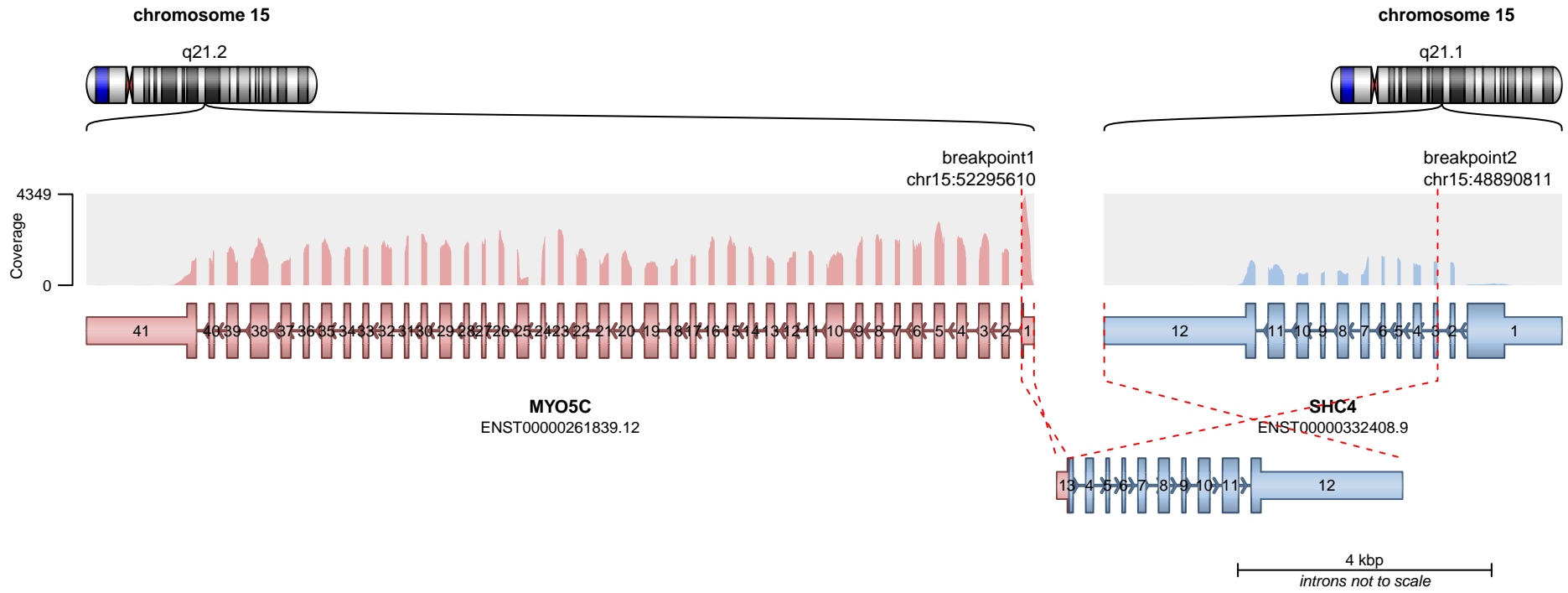

RETAINED PROTEIN DOMAINS
reading frame unclear

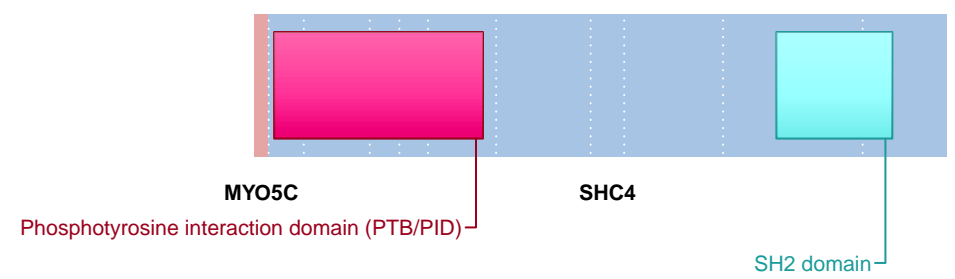

SUPPORTING READ COUNT

Split reads = 10
Discordant mates = 9

- translocation
- duplication
- deletion
- inversion

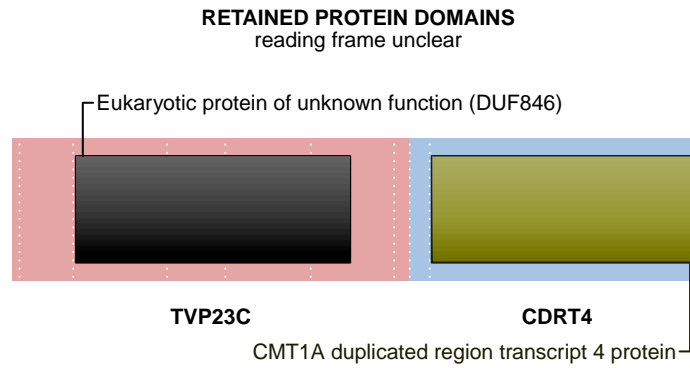
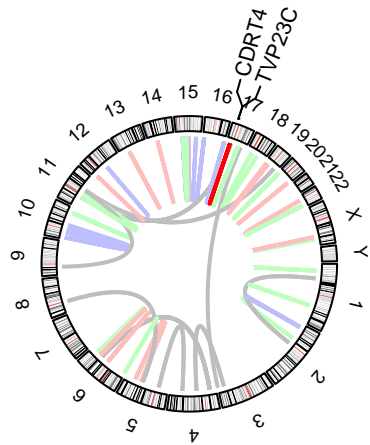
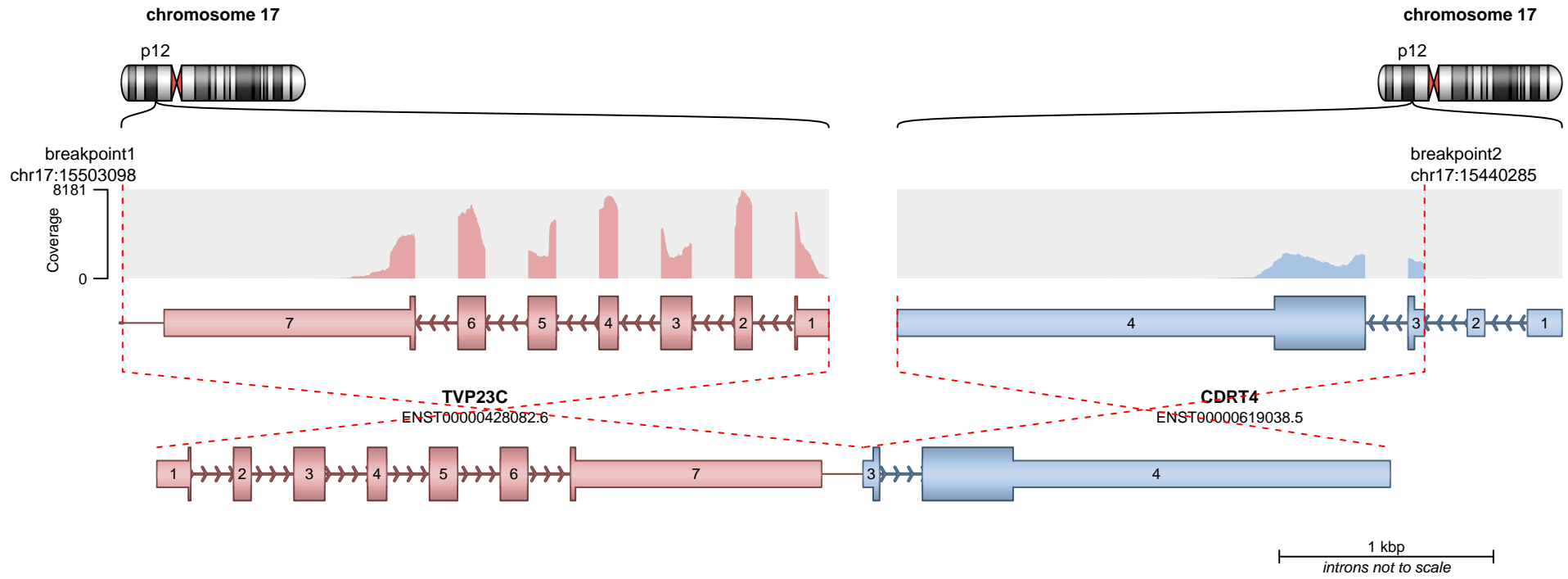

SUPPORTING READ COUNT

Split reads = 320
Discordant mates = 14

— translocation — deletion
— duplication — inversion

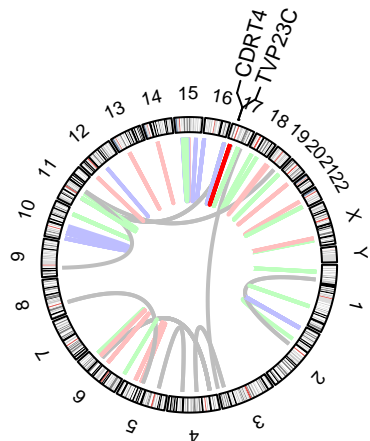
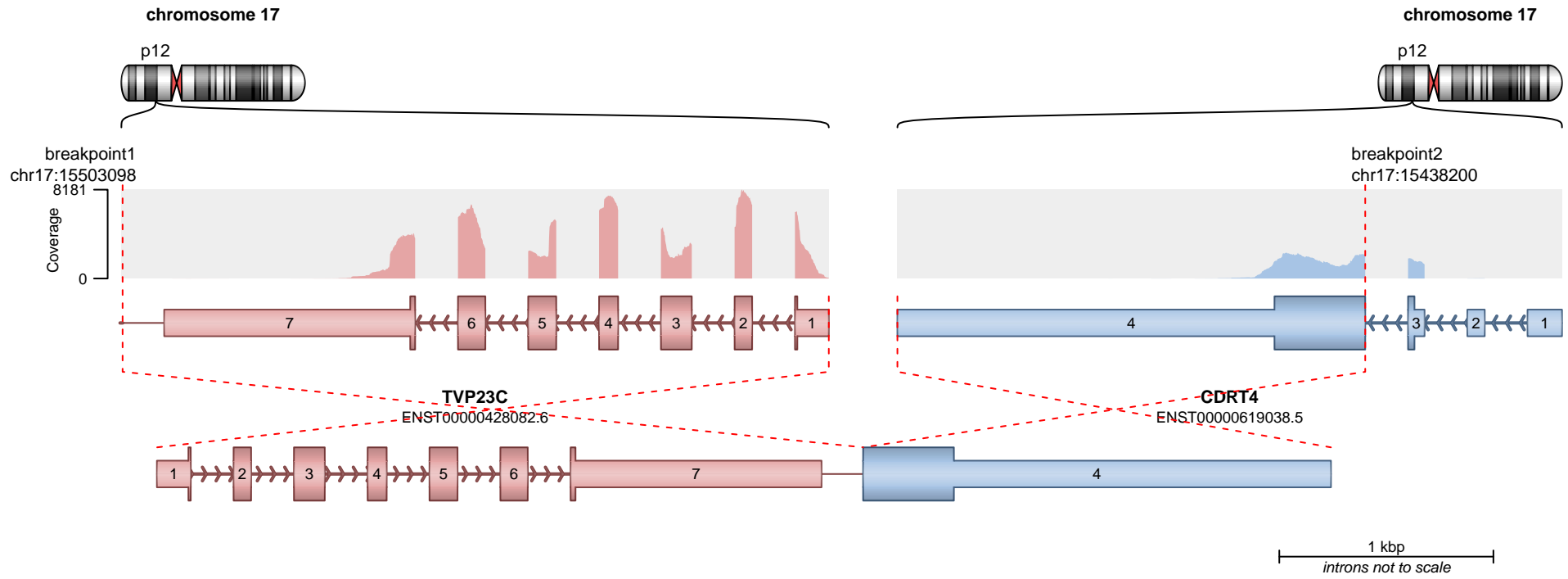

RETAINED PROTEIN DOMAINS
reading frame unclear

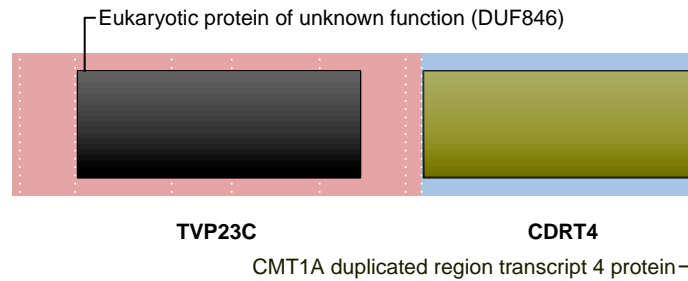

SUPPORTING READ COUNT

Split reads = 74
Discordant mates = 4

— translocation — deletion
— duplication — inversion

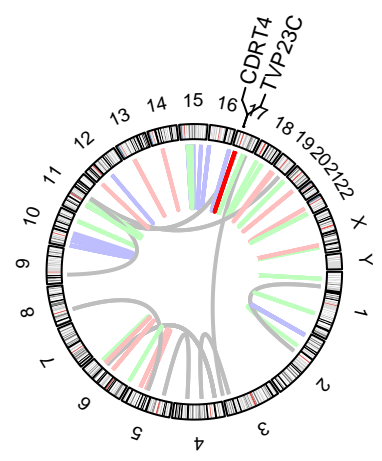
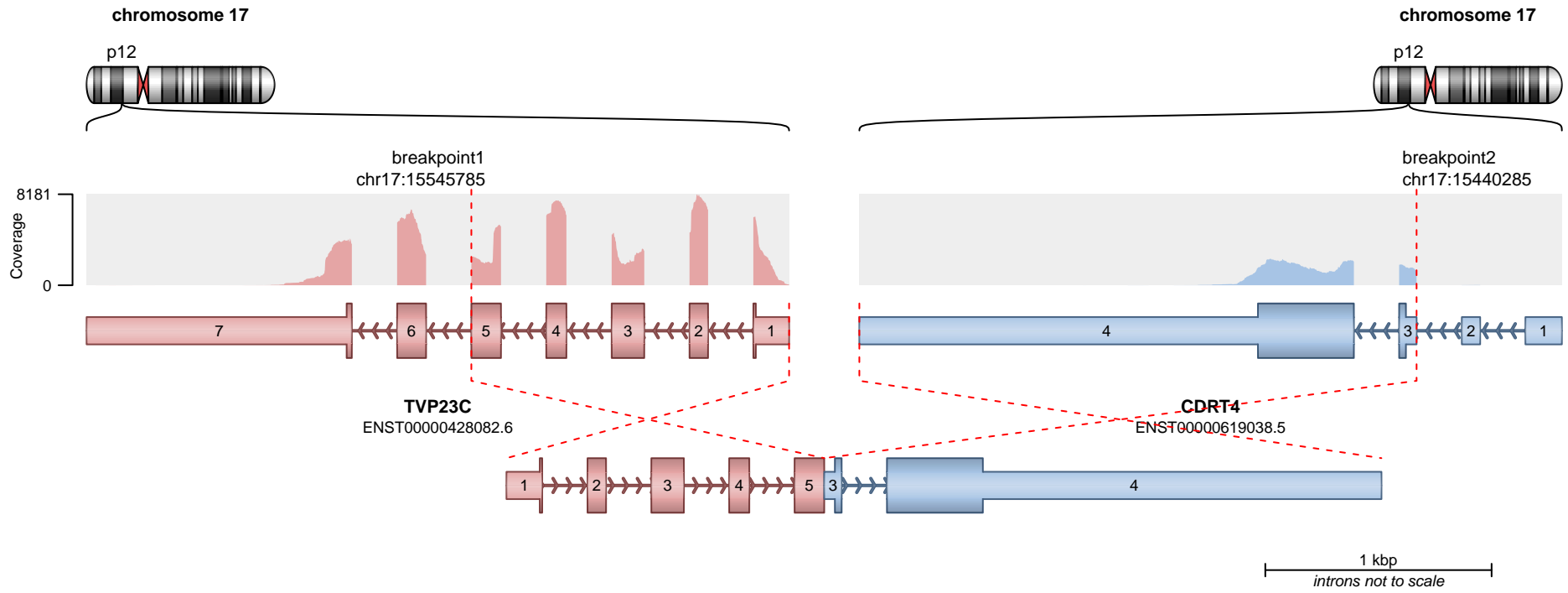

RETAINED PROTEIN DOMAINS
reading frame unclear

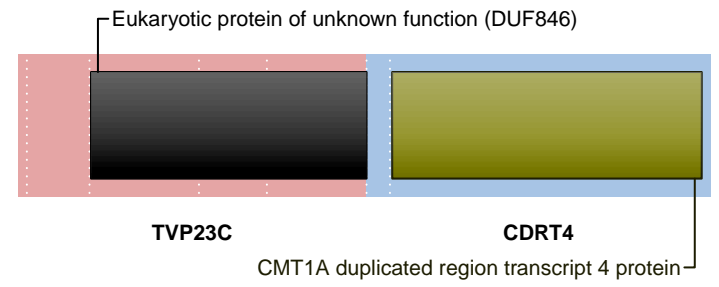

SUPPORTING READ COUNT

Split reads = 55
Discordant mates = 3

- translocation
- duplication
- deletion
- inversion

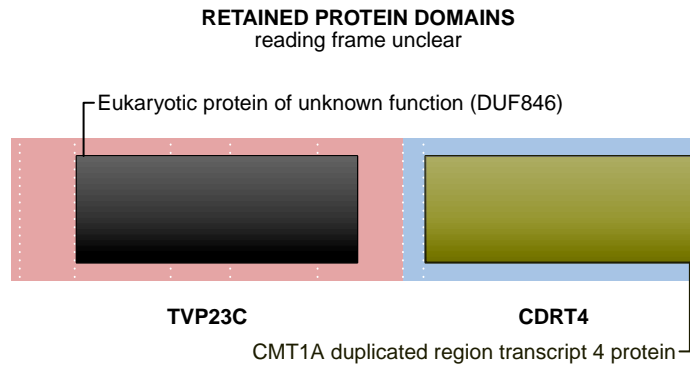
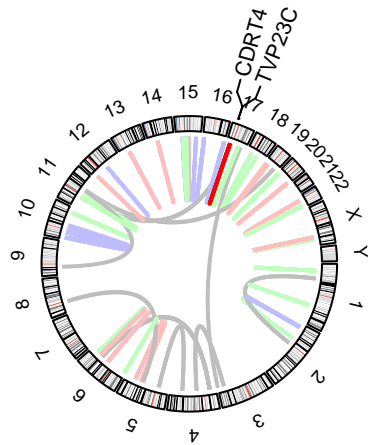
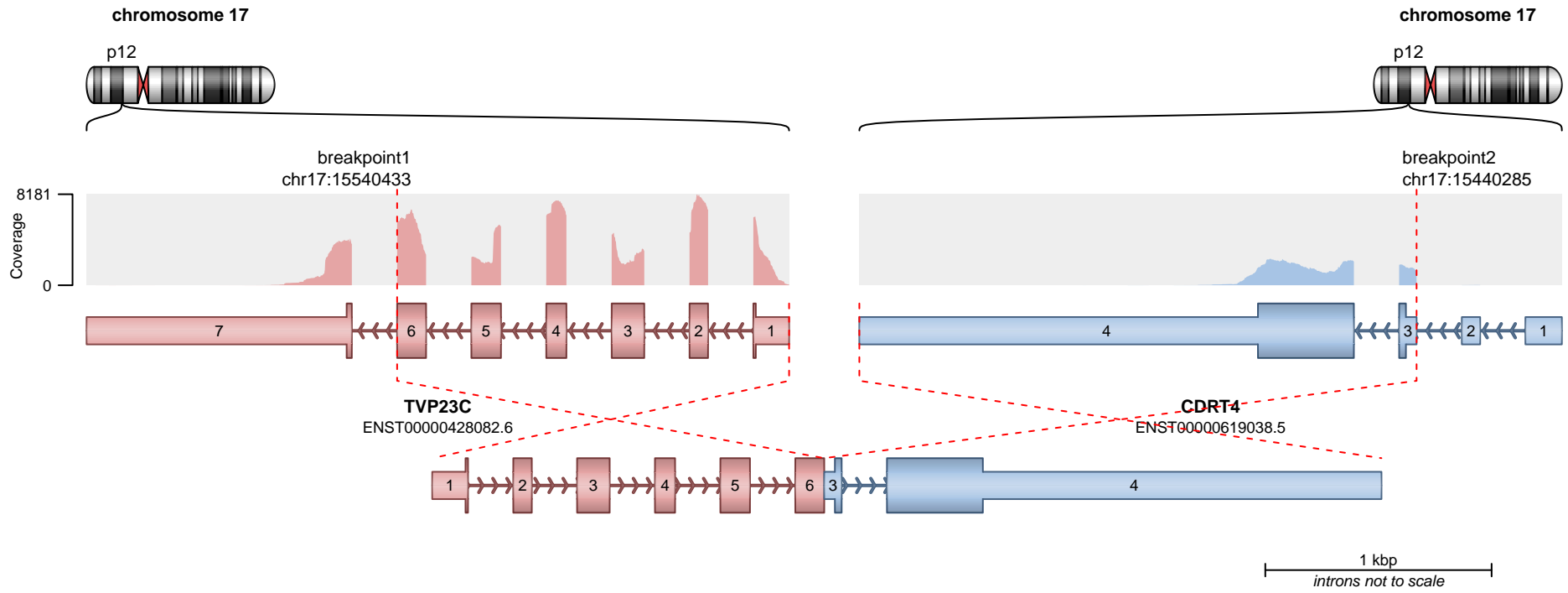

SUPPORTING READ COUNT

Split reads = 50
Discordant mates = 4

— translocation — deletion
— duplication — inversion

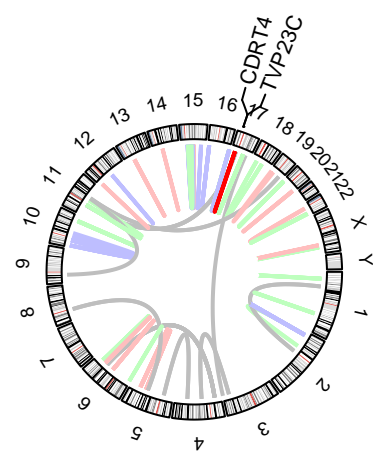
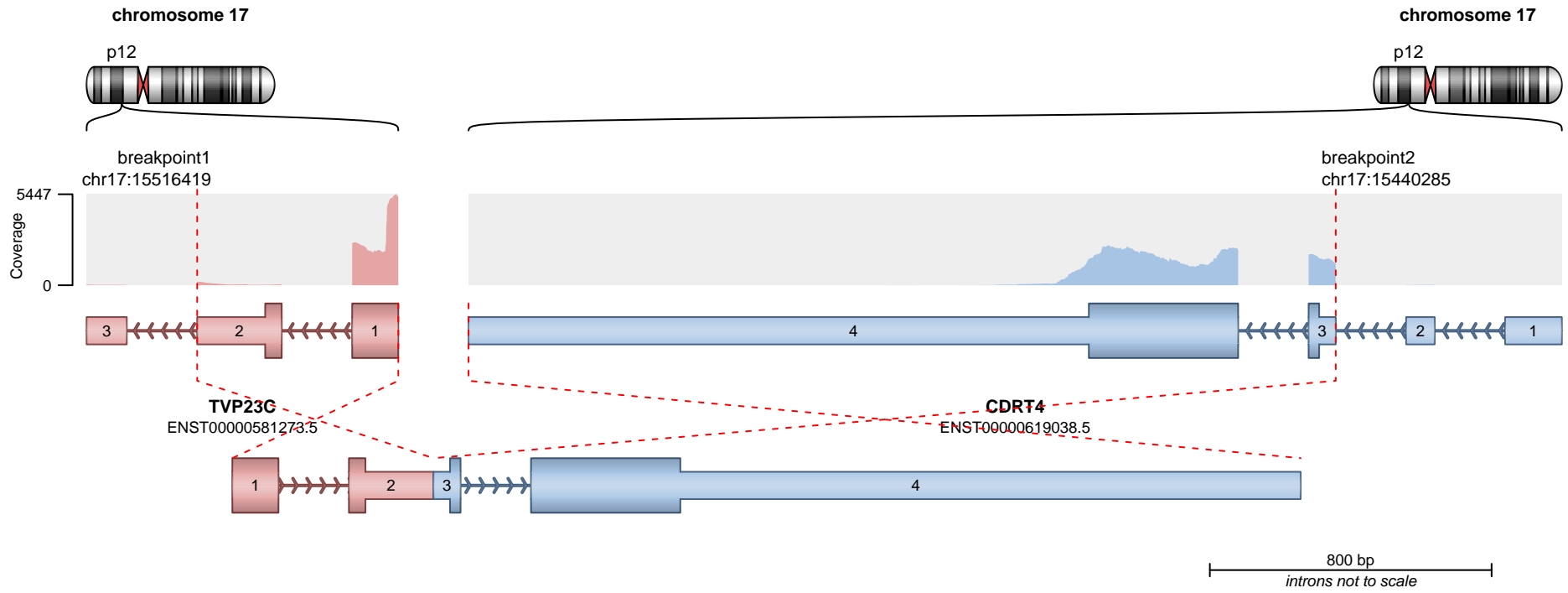

RETAINED PROTEIN DOMAINS
reading frame unclear

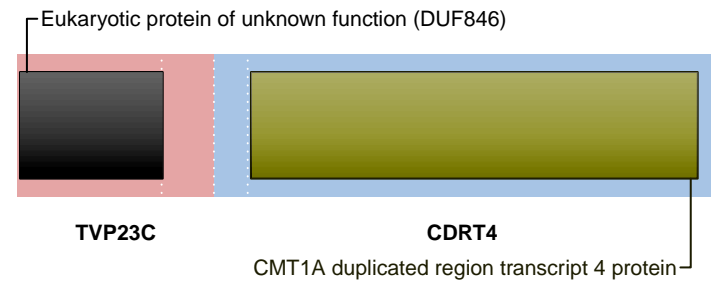

SUPPORTING READ COUNT

Split reads = 33
Discordant mates = 6

- translocation
- duplication
- deletion
- inversion

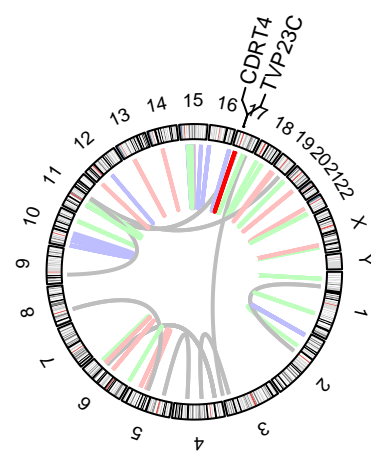
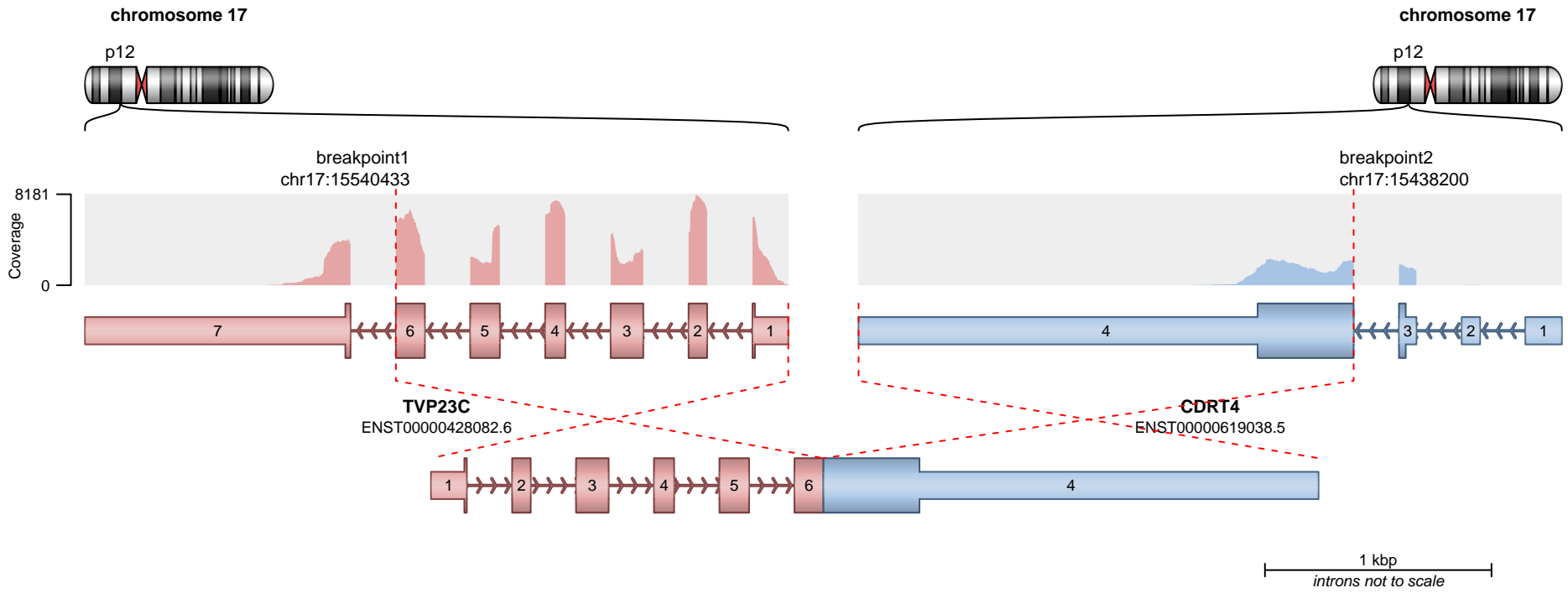

RETAINED PROTEIN DOMAINS
reading frame unclear

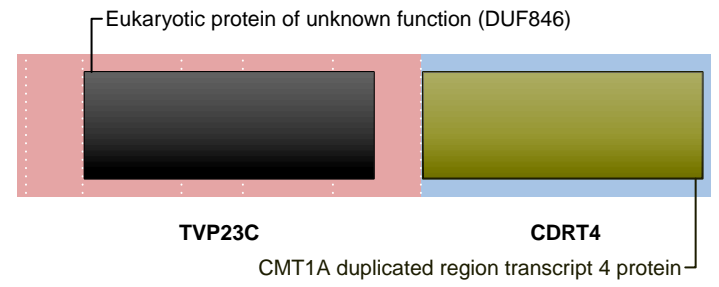

SUPPORTING READ COUNT

Split reads = 22
Discordant mates = 1

- translocation
- duplication
- deletion
- inversion

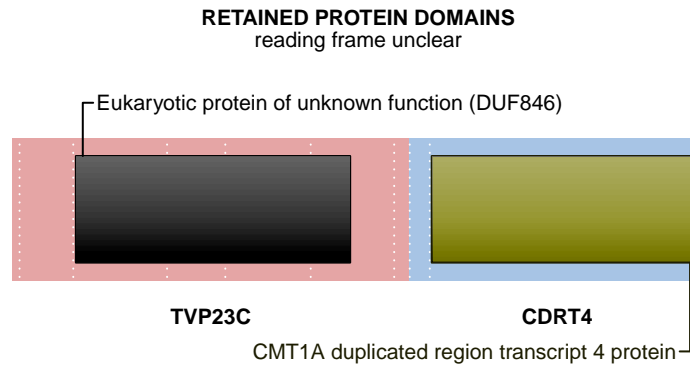
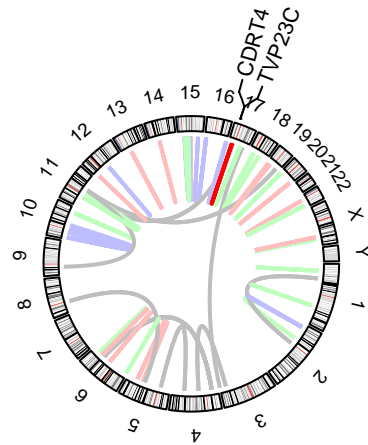
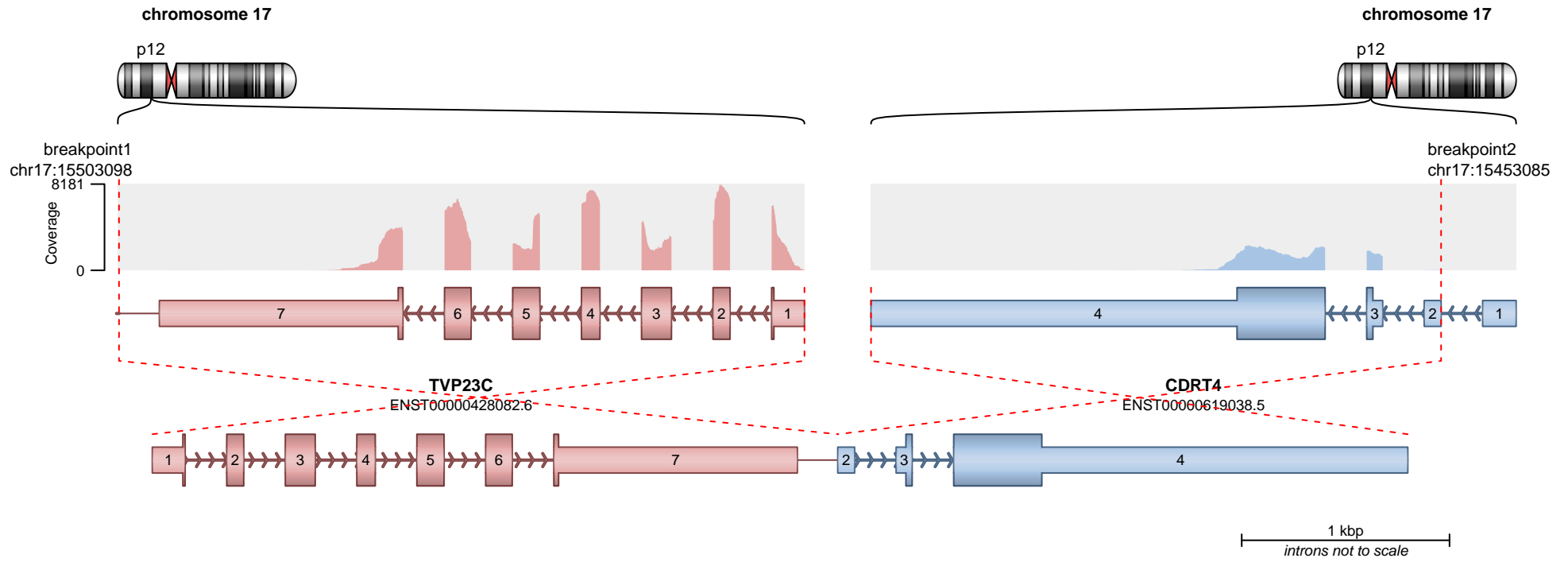

SUPPORTING READ COUNT

Split reads = 9
Discordant mates = 14

— translocation — deletion
— duplication — inversion

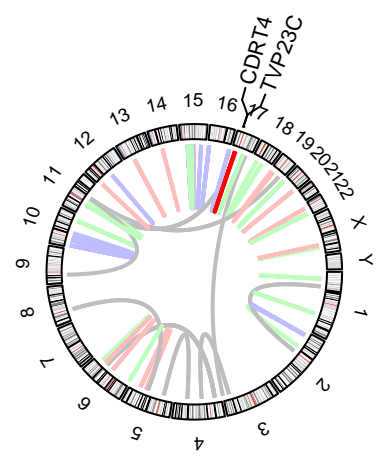
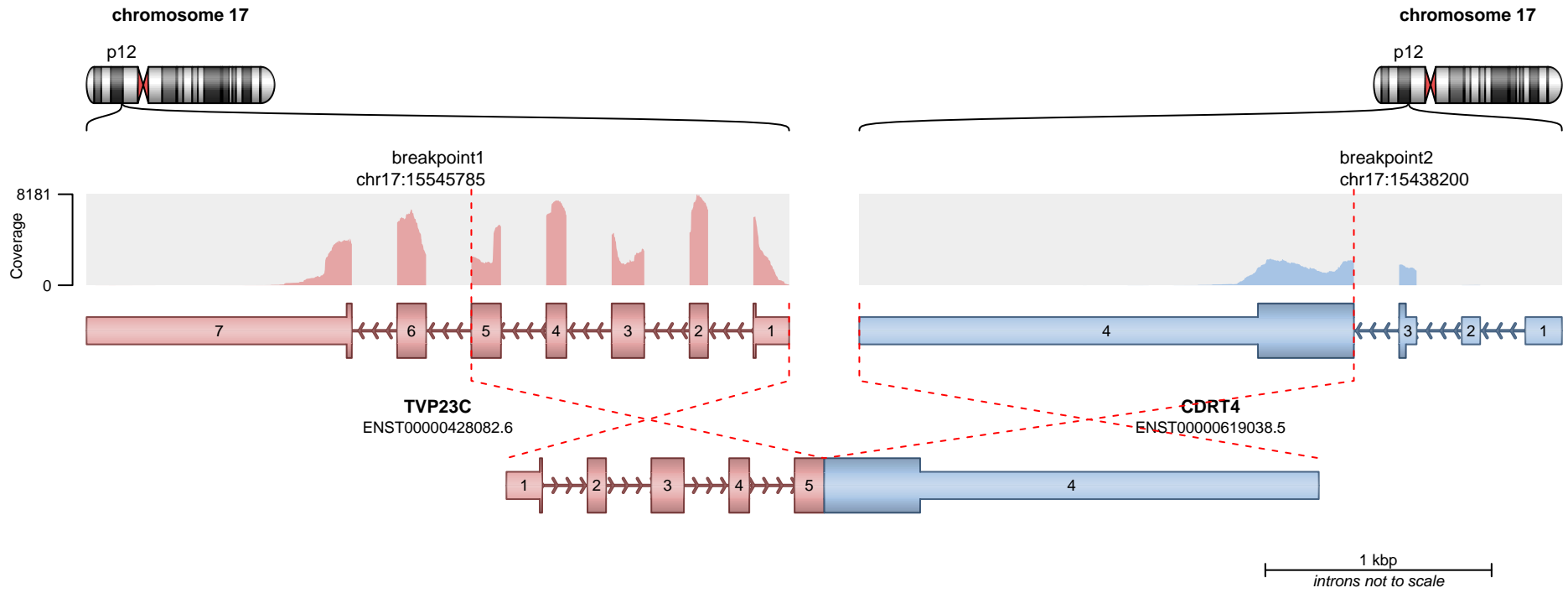

RETAINED PROTEIN DOMAINS
reading frame unclear

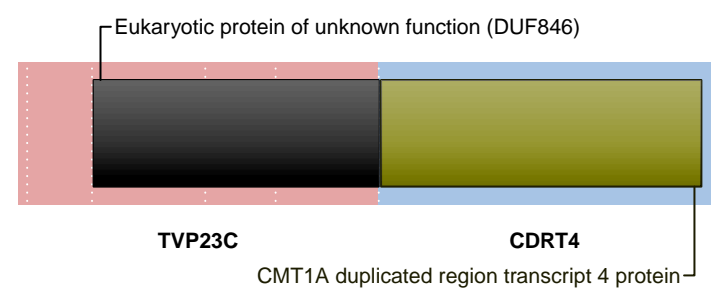

SUPPORTING READ COUNT

Split reads = 8
Discordant mates = 0

- translocation
- duplication
- deletion
- inversion

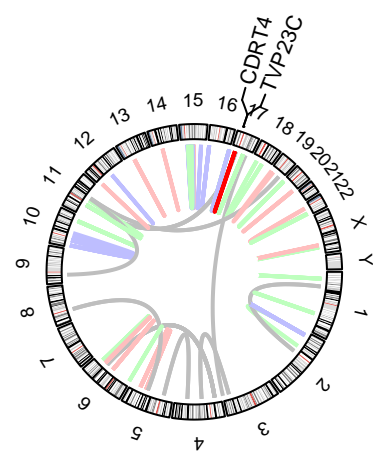
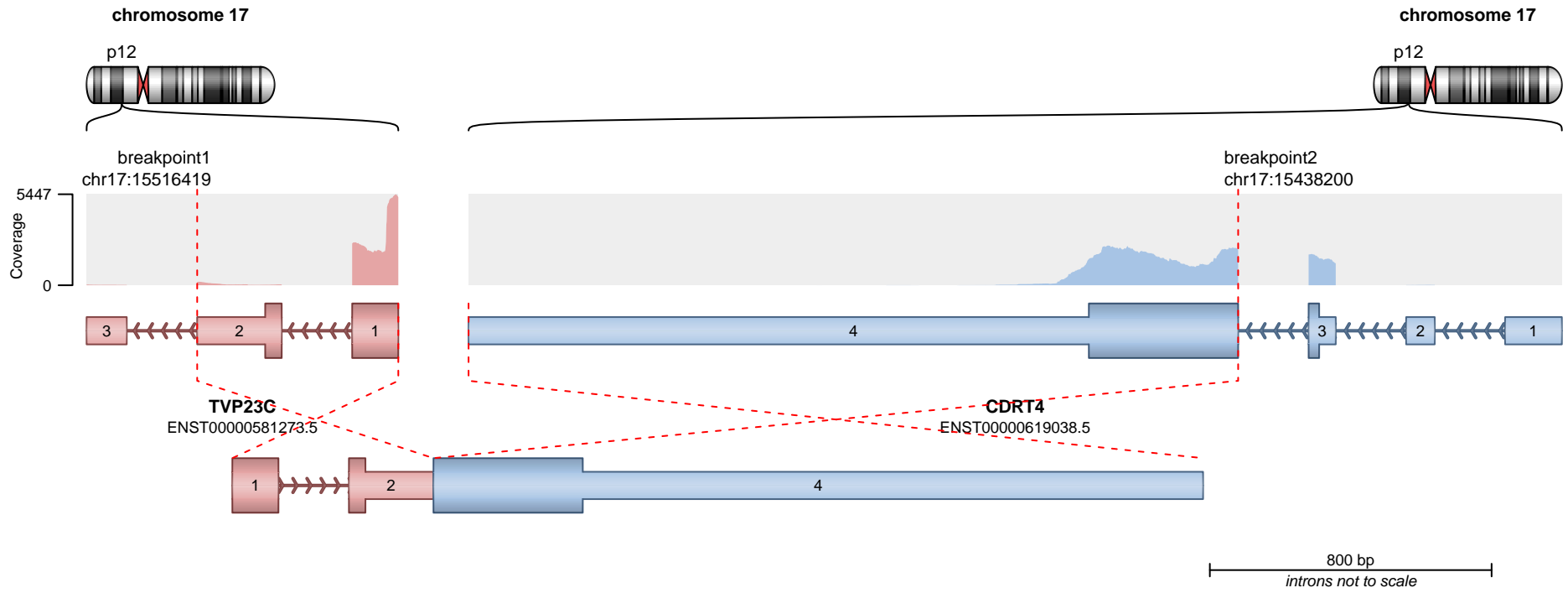

RETAINED PROTEIN DOMAINS
reading frame unclear

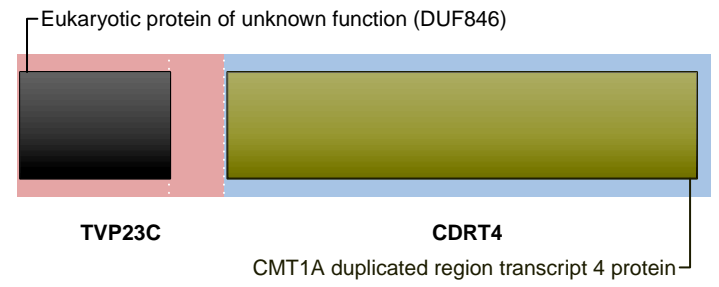

SUPPORTING READ COUNT

Split reads = 3
Discordant mates = 1

- translocation
- duplication
- deletion
- inversion

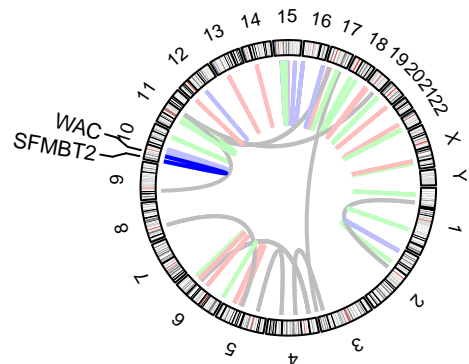
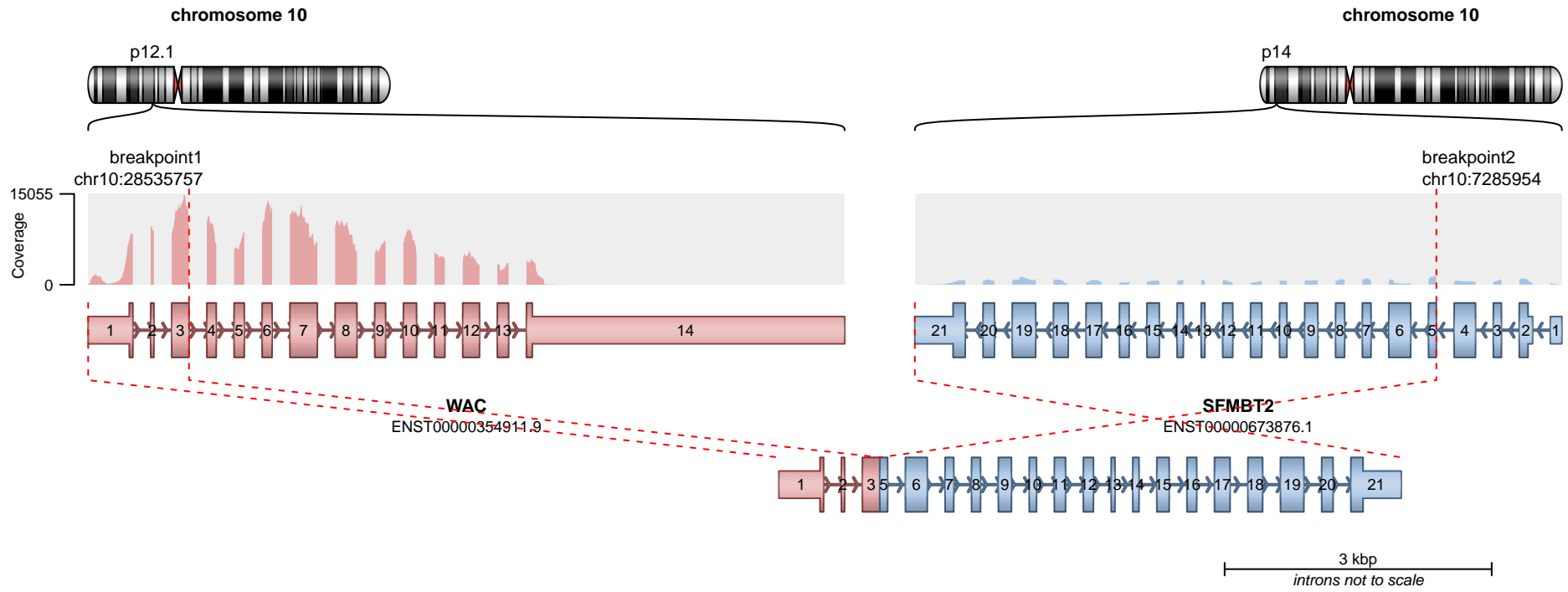

— translocation — deletion
— duplication — inversion

RETAINED PROTEIN DOMAINS
reading frame unclear

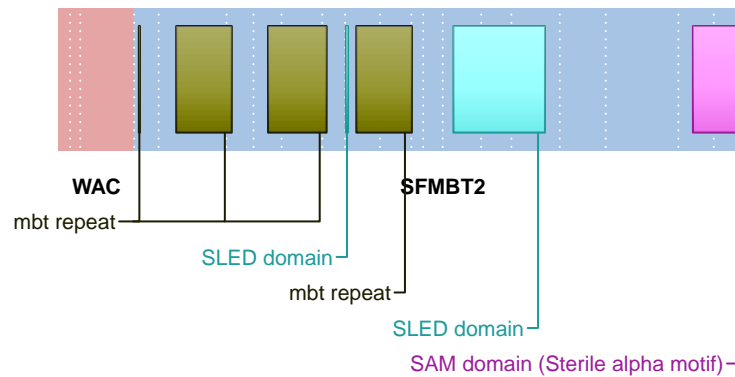

SUPPORTING READ COUNT

Split reads = 229
Discordant mates = 5

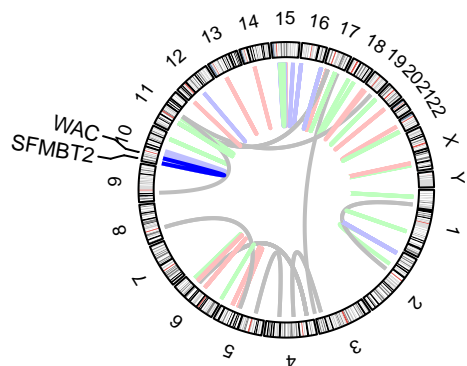
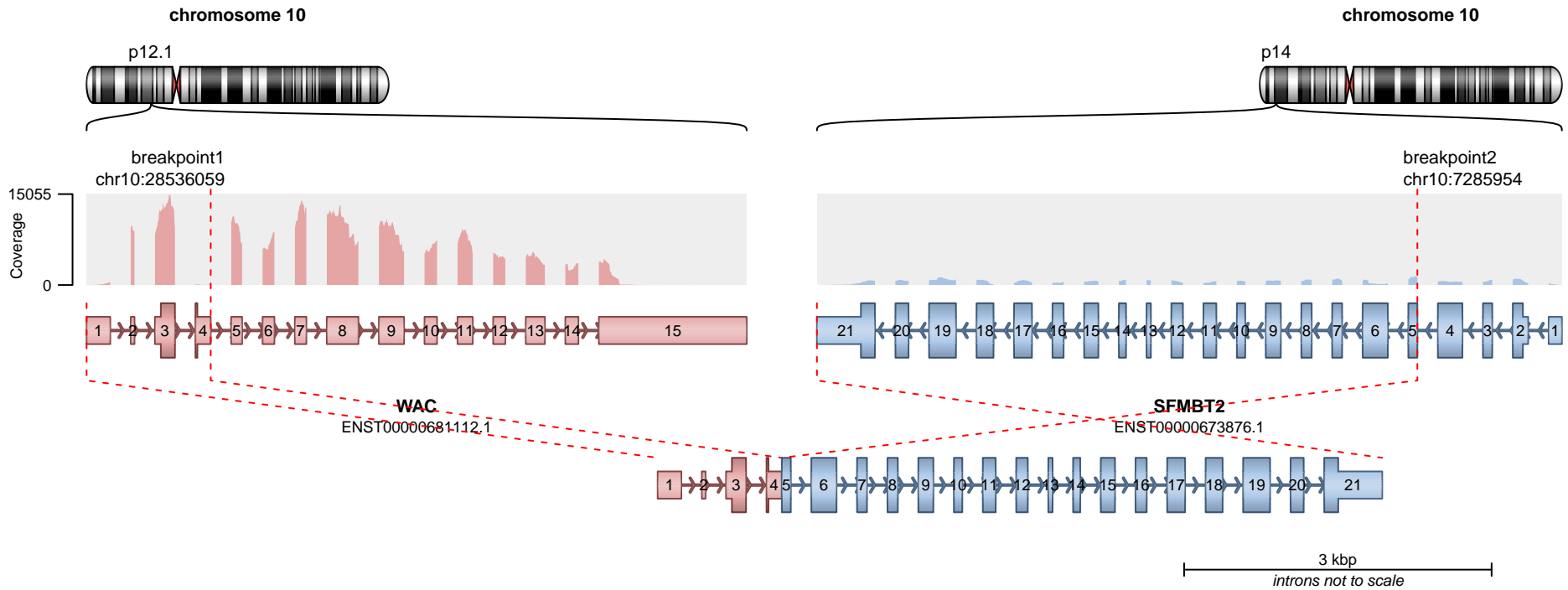

— translocation — deletion
— duplication — inversion

RETAINED PROTEIN DOMAINS
reading frame unclear

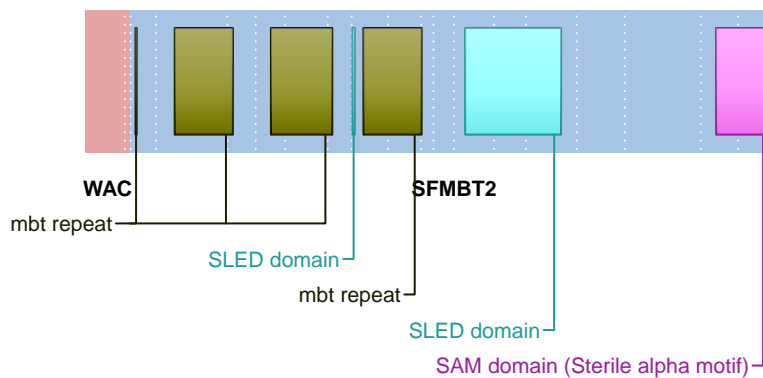

SUPPORTING READ COUNT

Split reads = 2
Discordant mates = 5

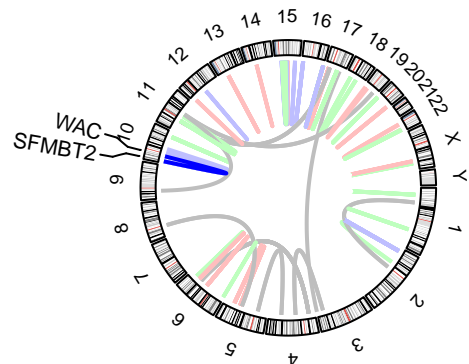
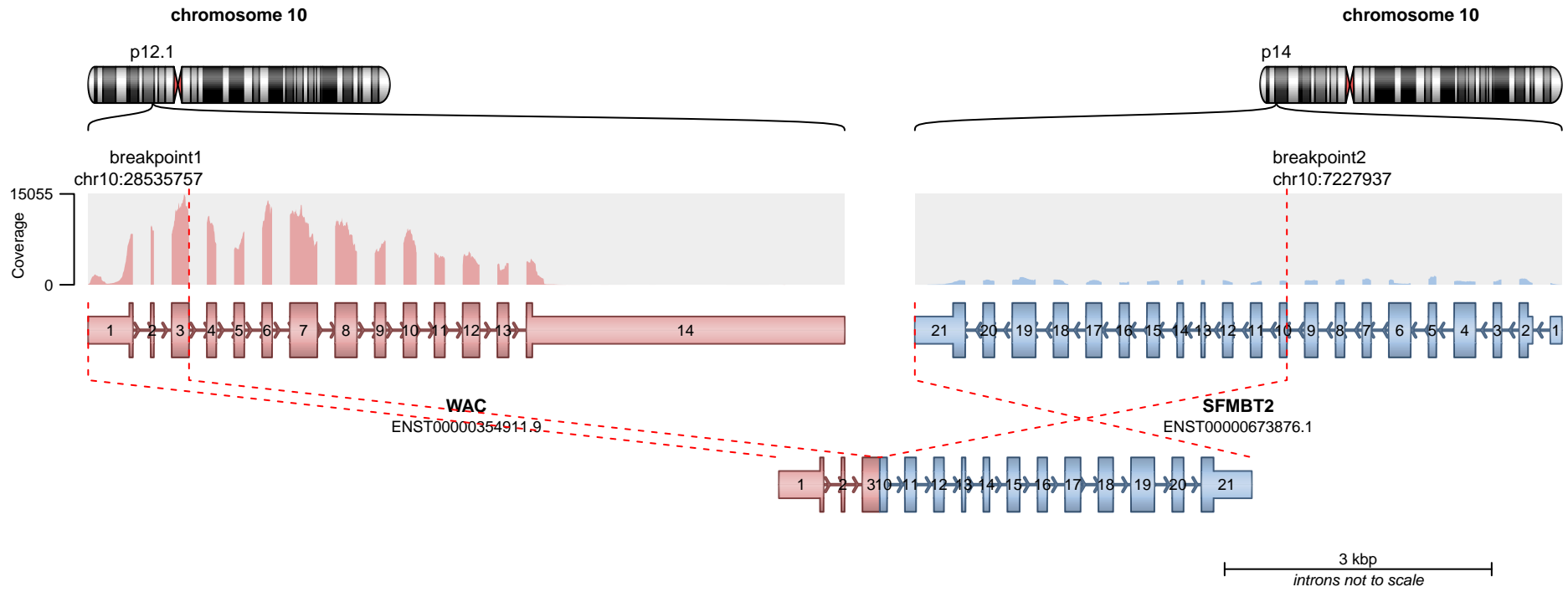

— translocation — deletion
— duplication — inversion

RETAINED PROTEIN DOMAINS
reading frame unclear

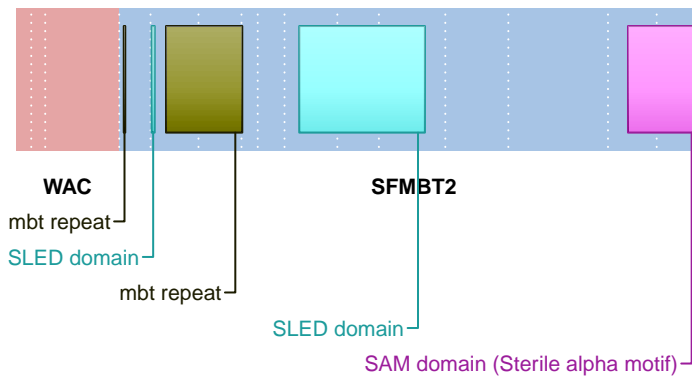

SUPPORTING READ COUNT

Split reads = 2
Discordant mates = 0

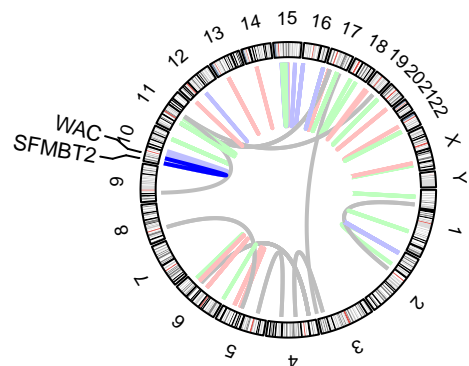
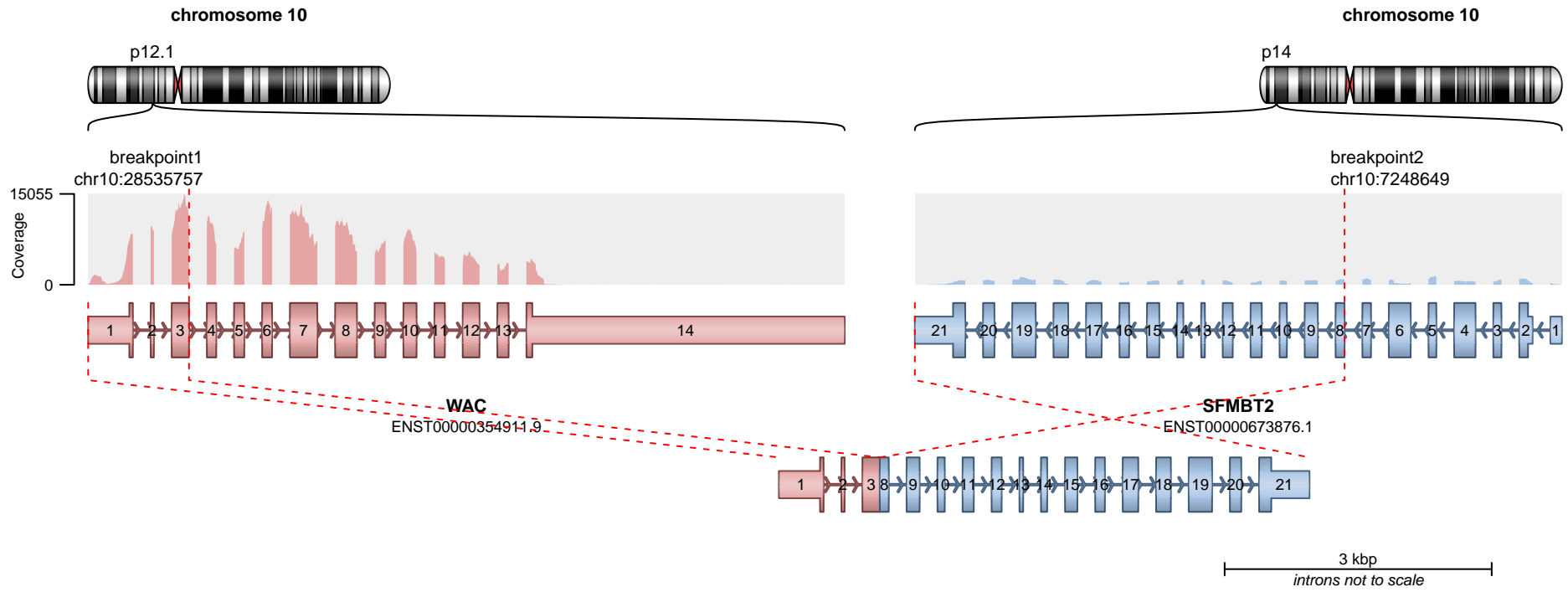

— translocation — deletion
— duplication — inversion

RETAINED PROTEIN DOMAINS
reading frame unclear

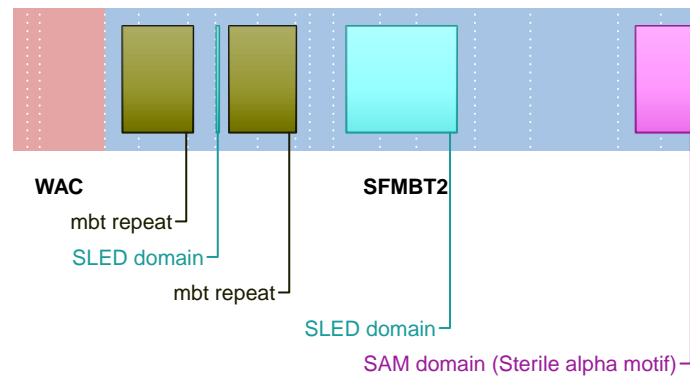

SUPPORTING READ COUNT

Split reads = 2
Discordant mates = 0

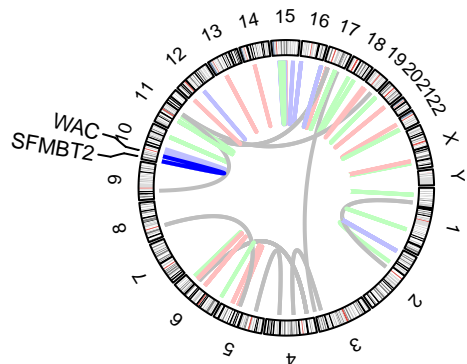
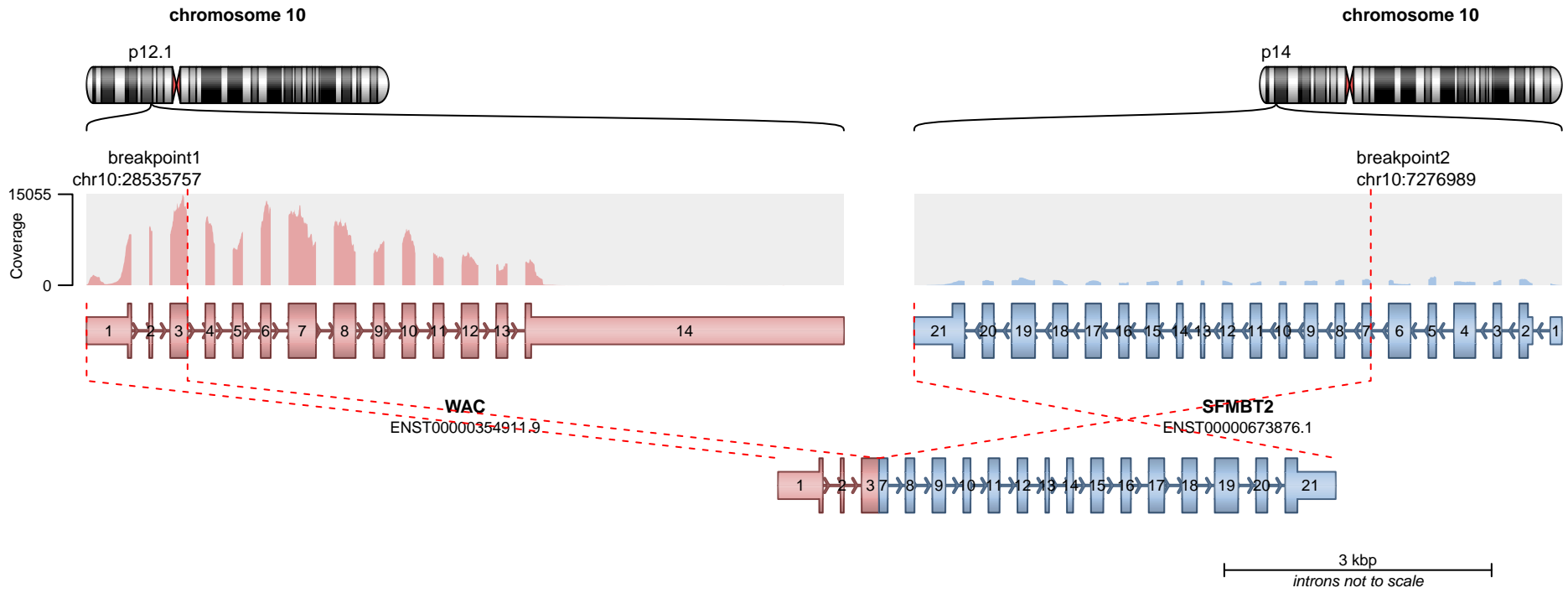

— translocation — deletion
— duplication — inversion

RETAINED PROTEIN DOMAINS
reading frame unclear

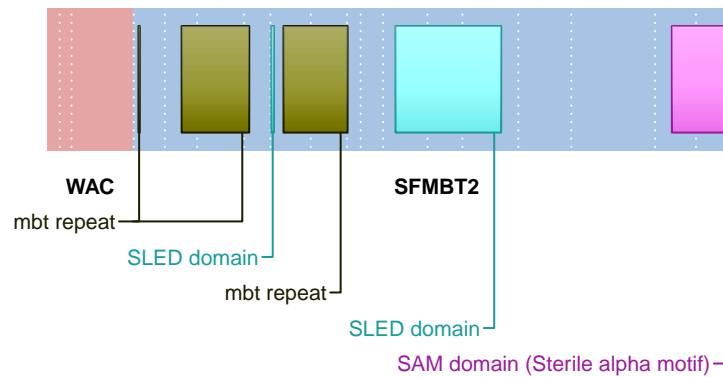

SUPPORTING READ COUNT

Split reads = 1
Discordant mates = 0

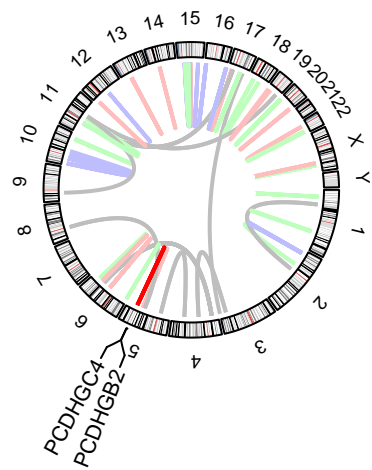
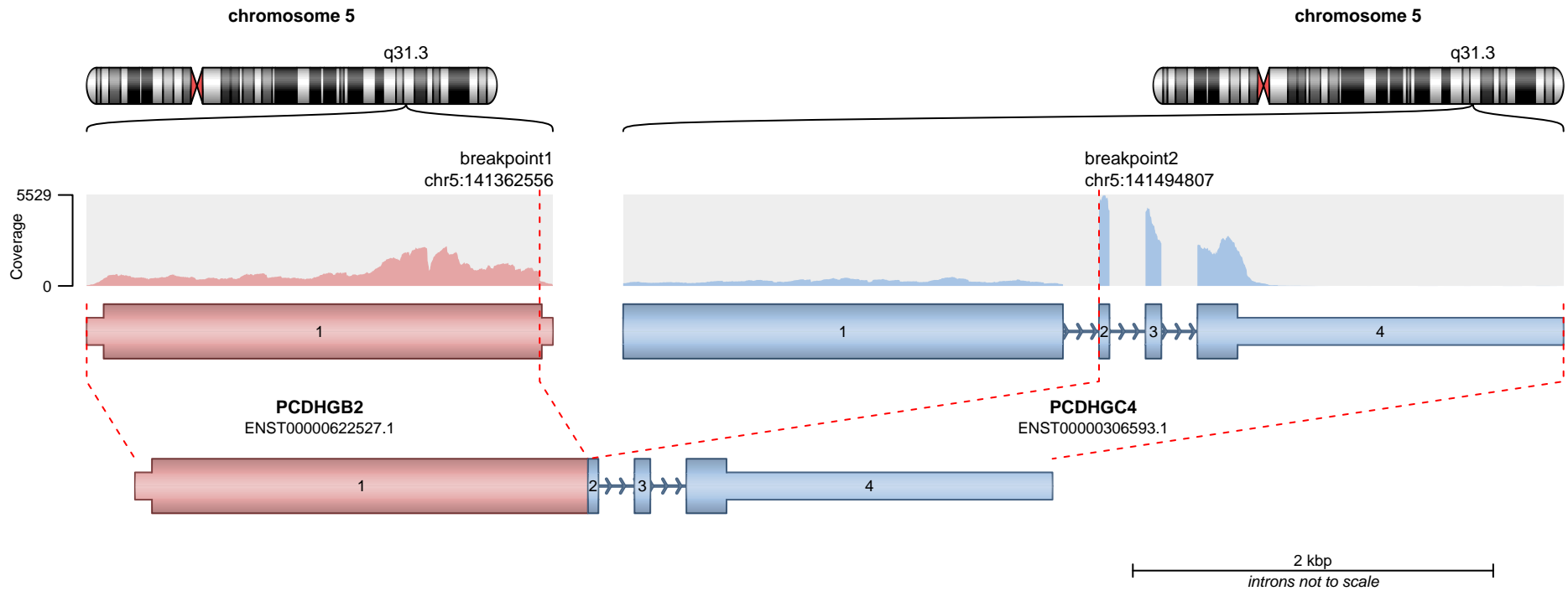

— translocation — deletion
— duplication — inversion

RETAINED PROTEIN DOMAINS
reading frame unclear

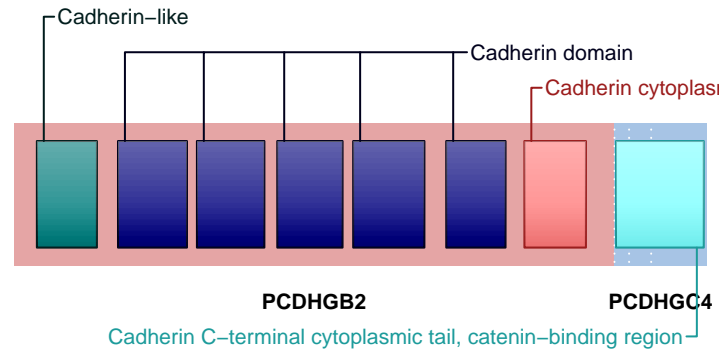

SUPPORTING READ COUNT

Split reads = 176
Discordant mates = 3

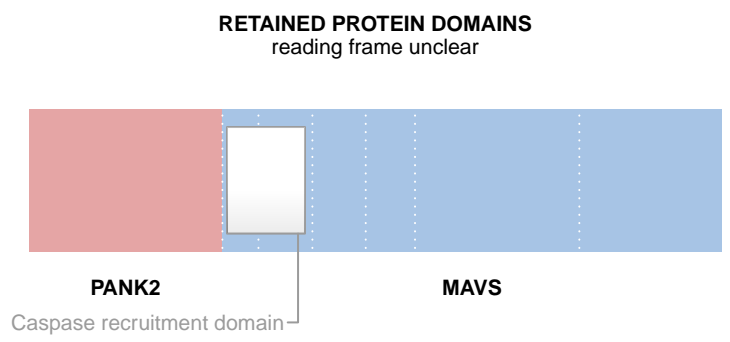
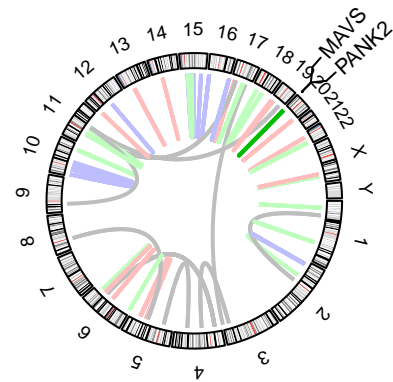
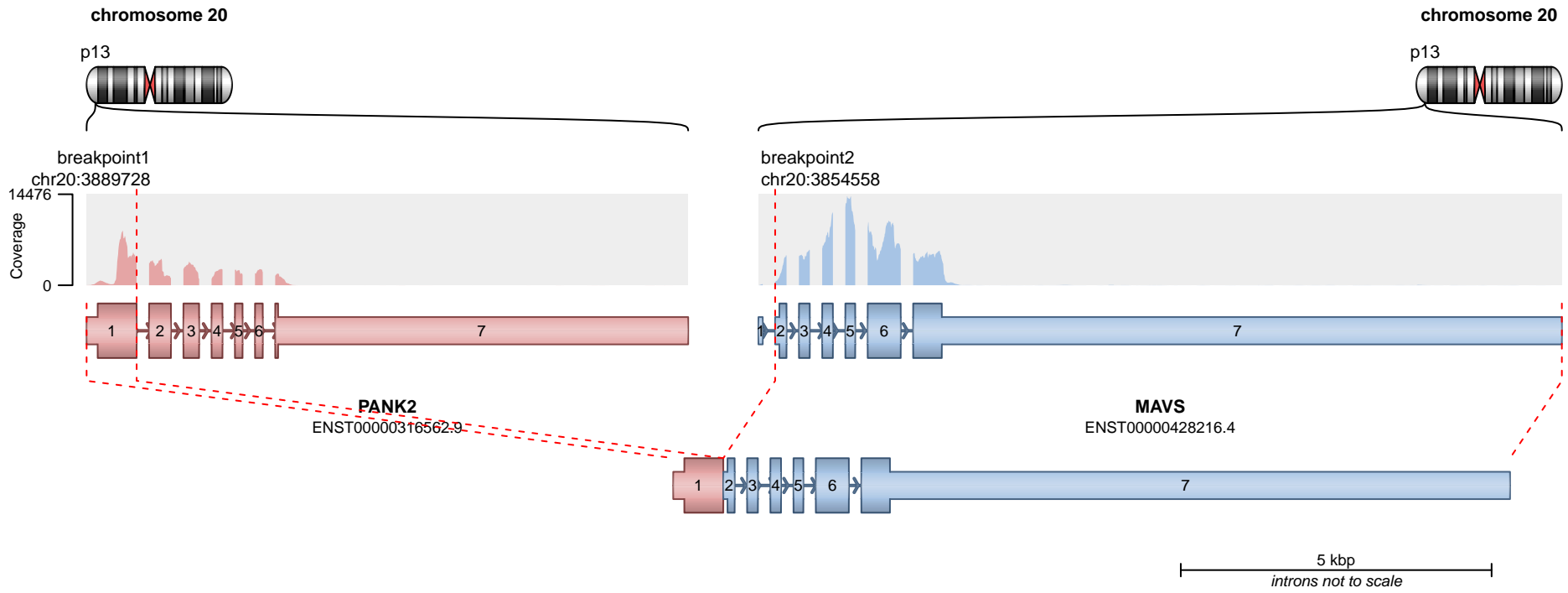

SUPPORTING READ COUNT

Split reads = 171
Discordant mates = 8

— translocation — deletion
— duplication — inversion

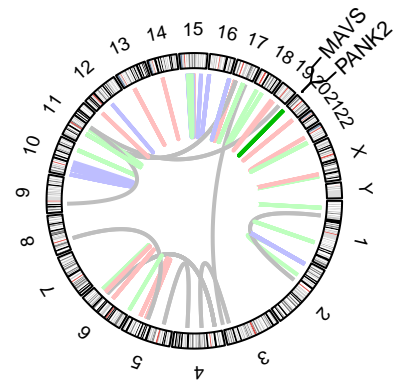
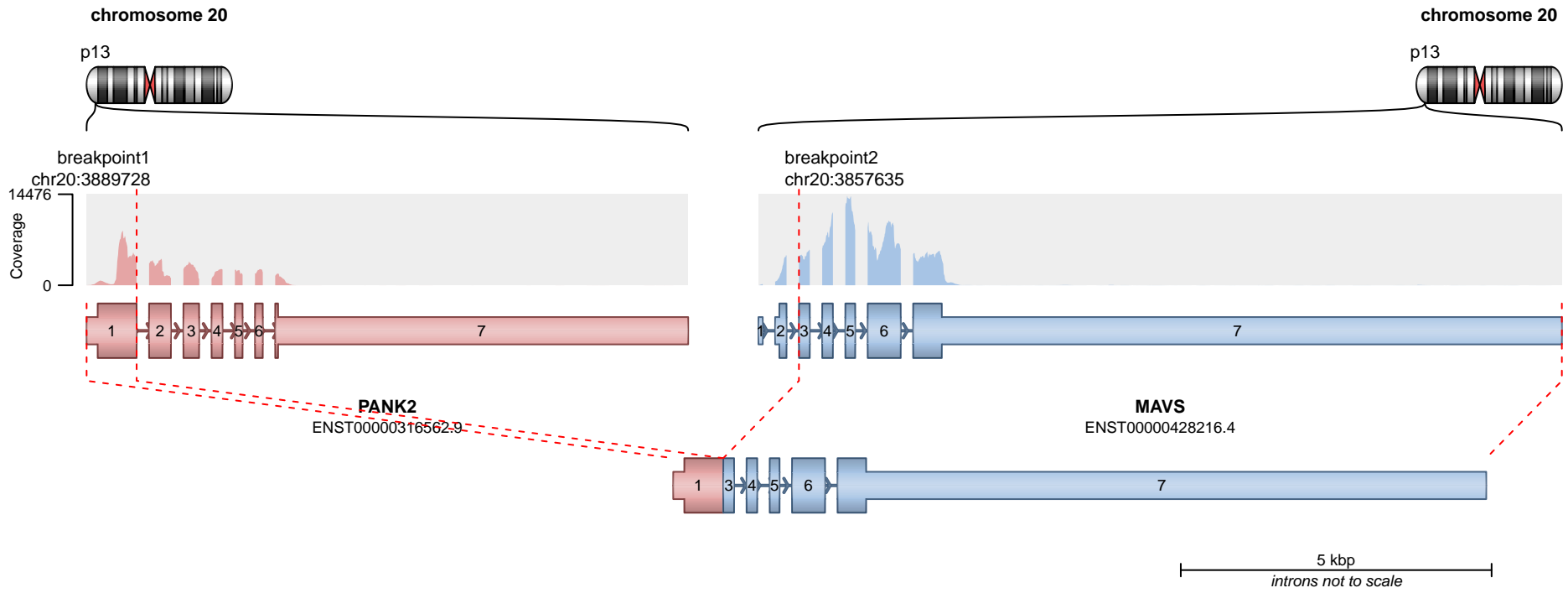

RETAINED PROTEIN DOMAINS
reading frame unclear

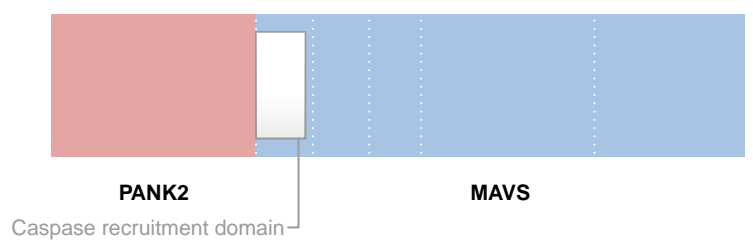

SUPPORTING READ COUNT

Split reads = 12
Discordant mates = 0

- translocation
- duplication
- deletion
- inversion

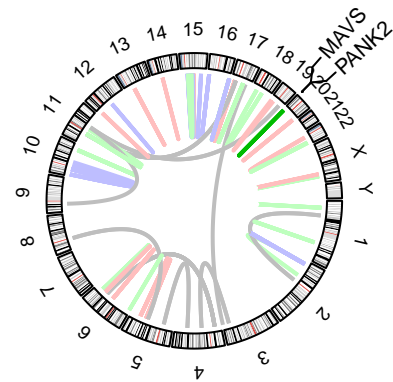
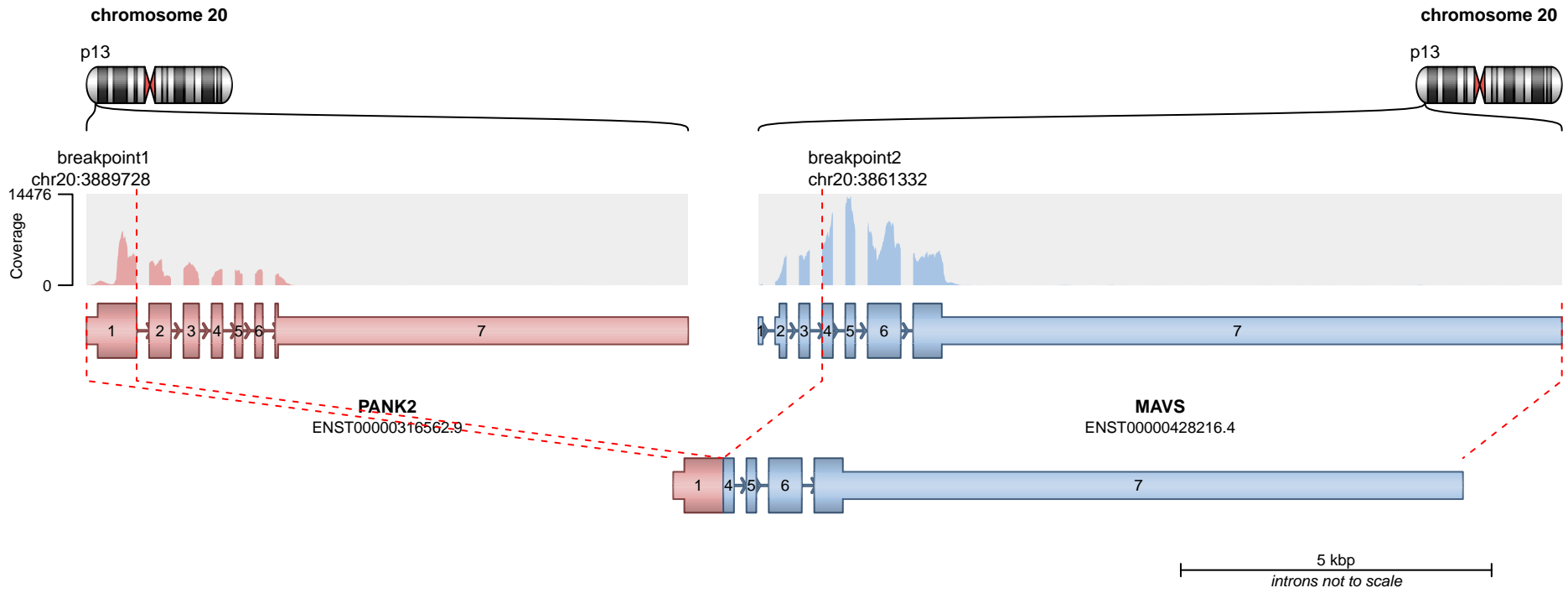

— translocation — deletion
— duplication — inversion

No protein domains retained in fusion.

SUPPORTING READ COUNT

Split reads = 3
Discordant mates = 0

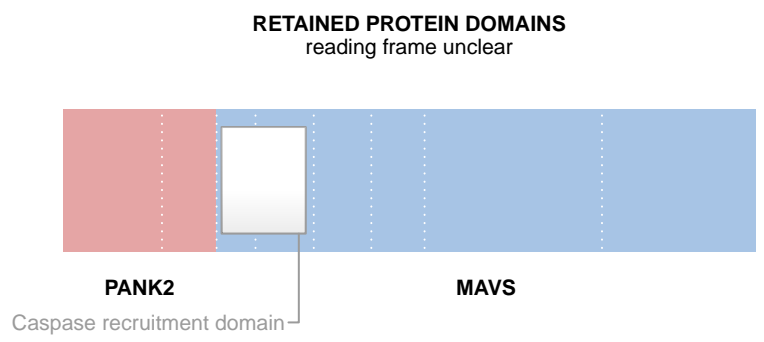
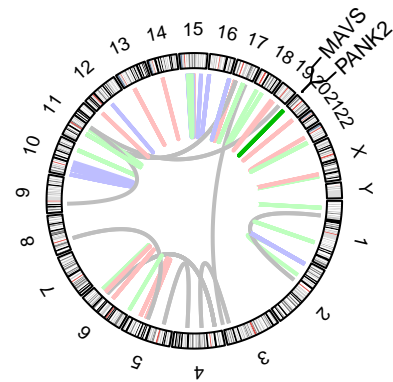
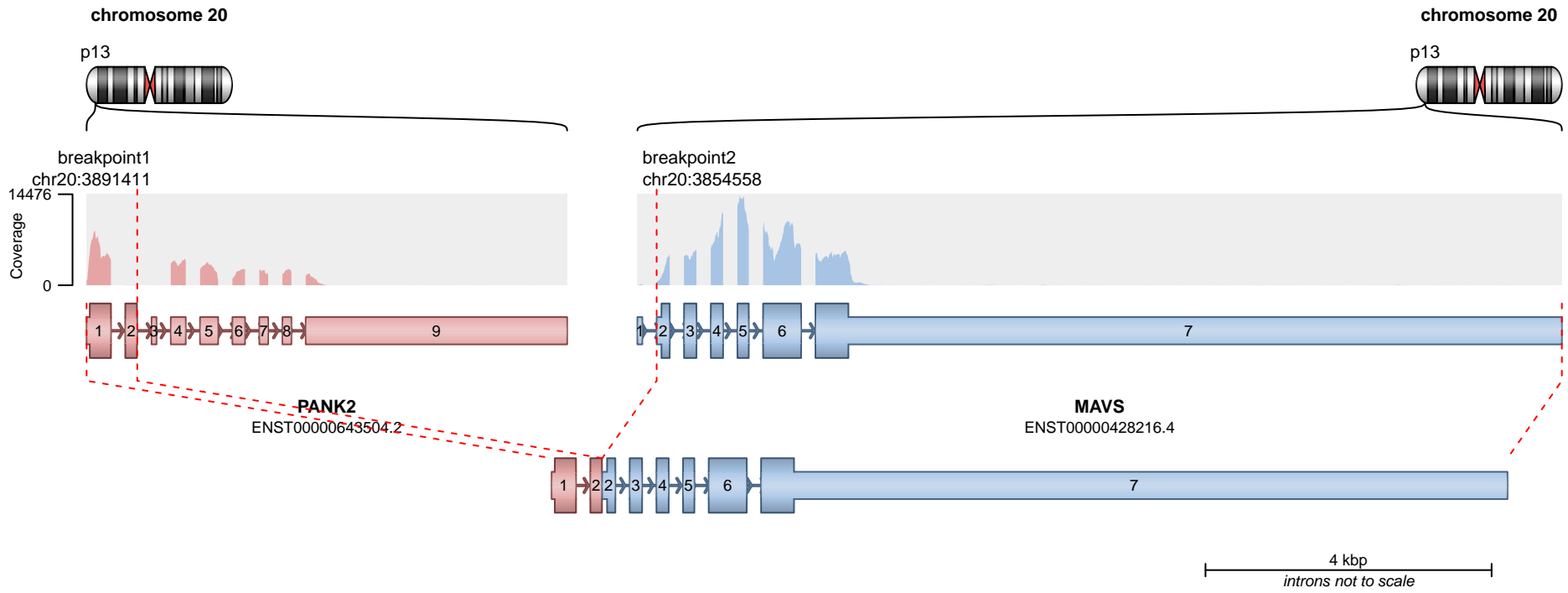

SUPPORTING READ COUNT

Split reads = 1
Discordant mates = 8

— translocation — deletion
— duplication — inversion

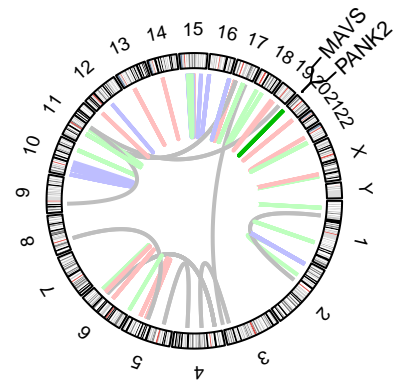
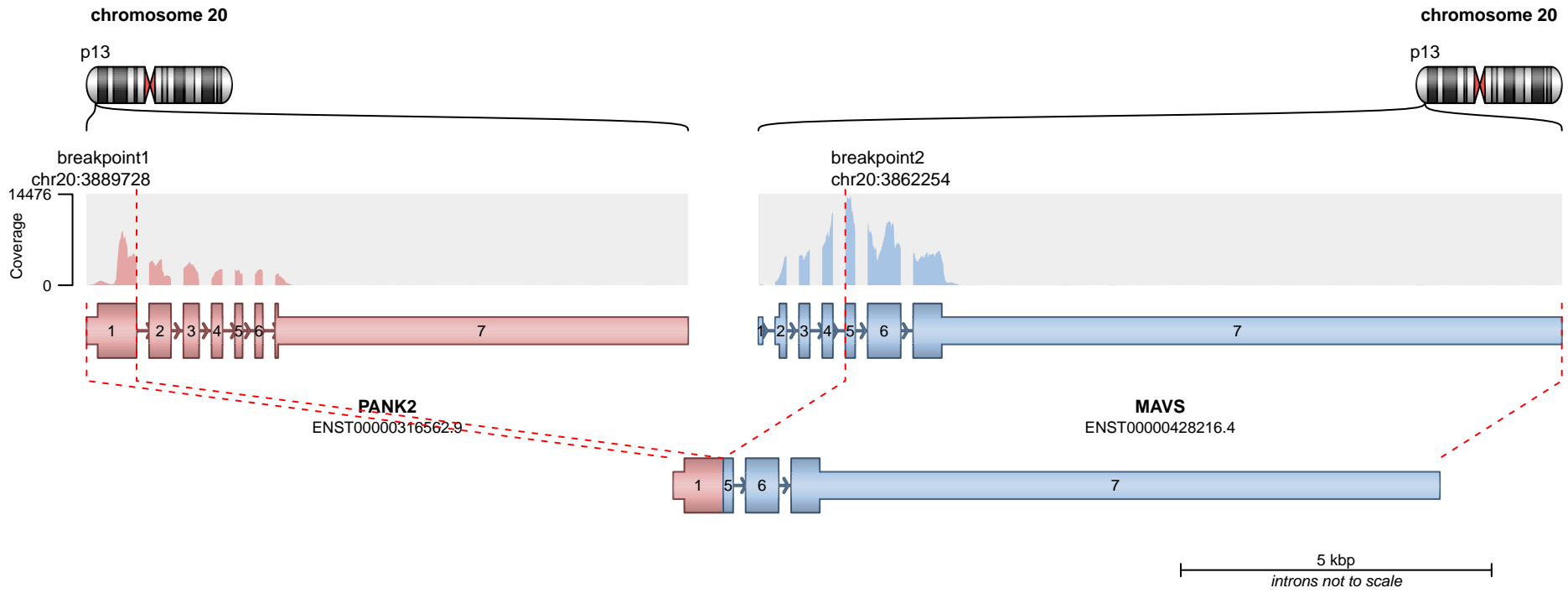

— translocation — deletion
— duplication — inversion

No protein domains retained in fusion.

SUPPORTING READ COUNT

Split reads = 1
Discordant mates = 0

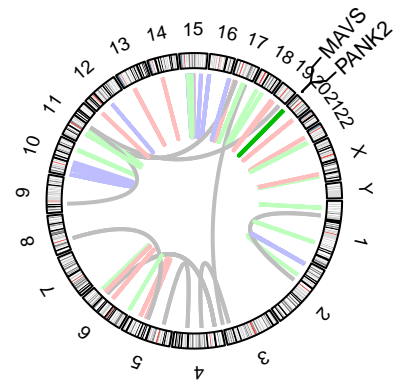
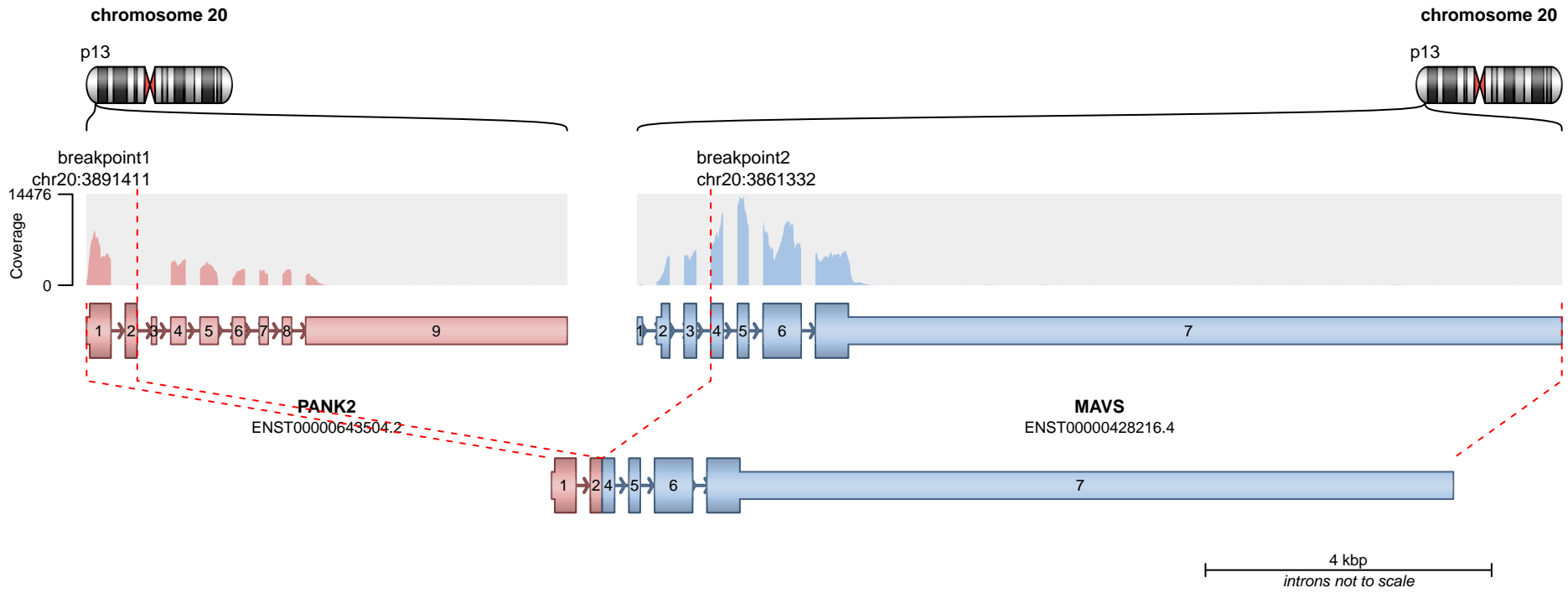

— translocation — deletion
— duplication — inversion

No protein domains retained in fusion.

SUPPORTING READ COUNT

Split reads = 1
Discordant mates = 0

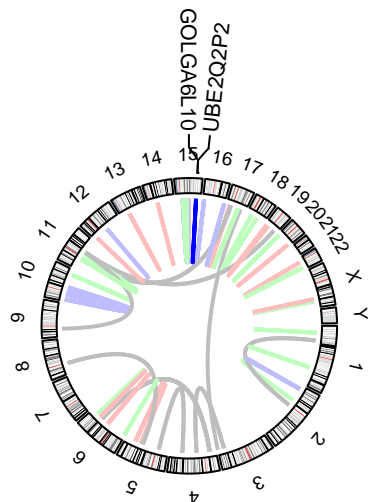
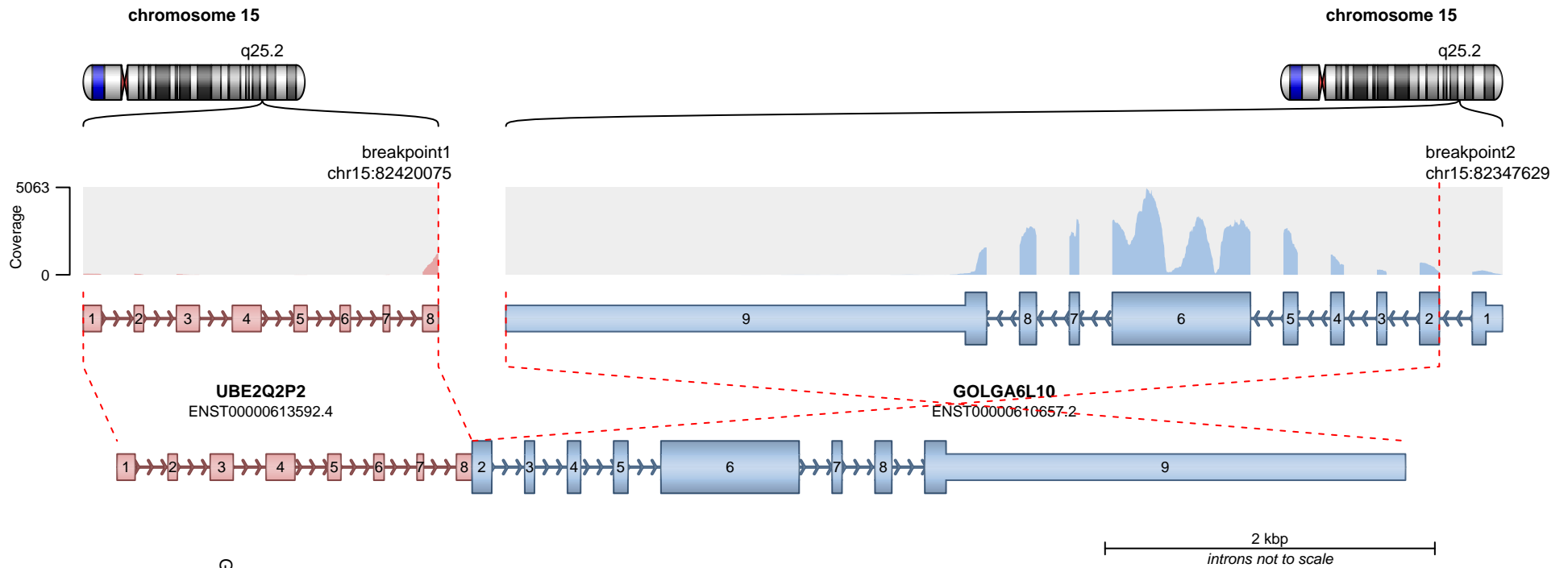

RETAINED PROTEIN DOMAINS
reading frame unclear



SUPPORTING READ COUNT

Split reads = 167
Discordant mates = 3

Putative golgin subfamily A member 2-like protein 5

- translocation
- duplication
- deletion
- inversion

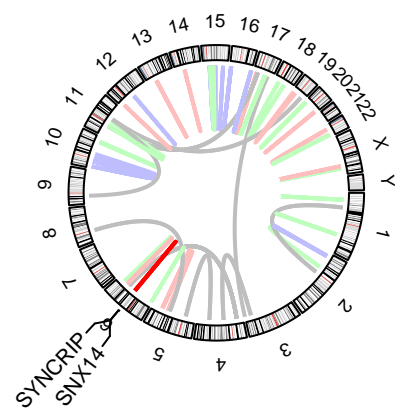
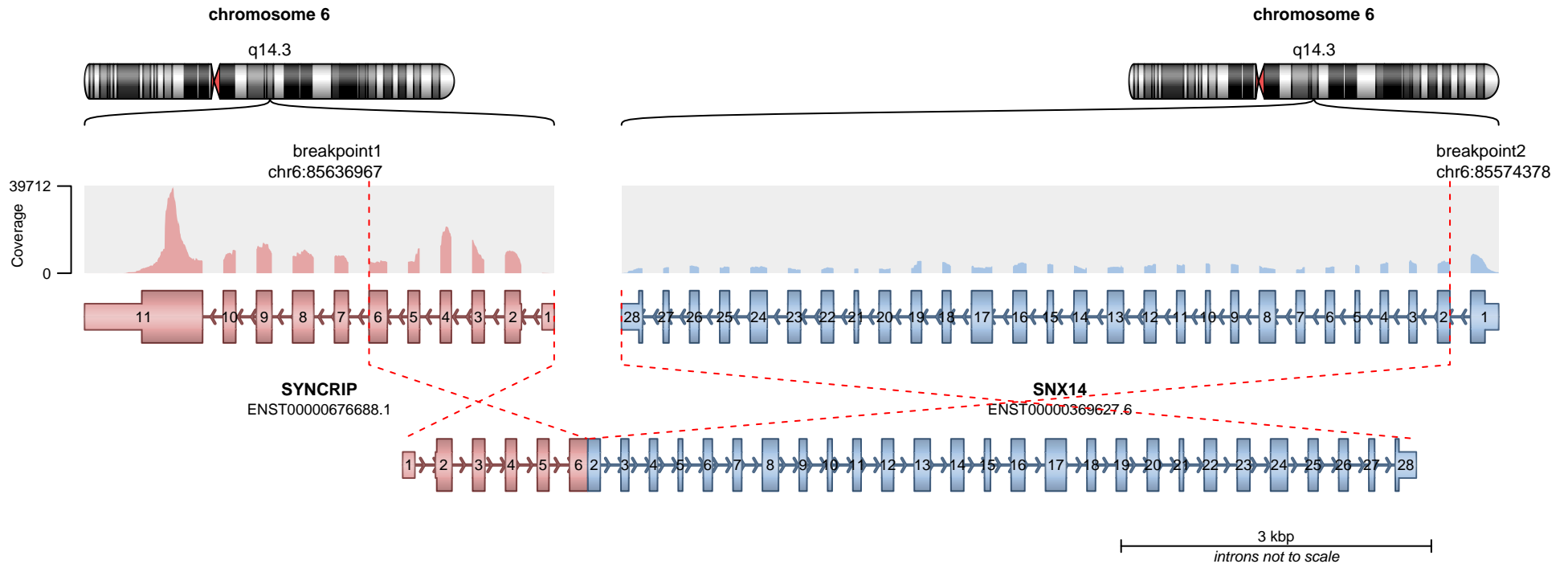

— translocation — deletion
— duplication — inversion

RETAINED PROTEIN DOMAINS
reading frame unclear

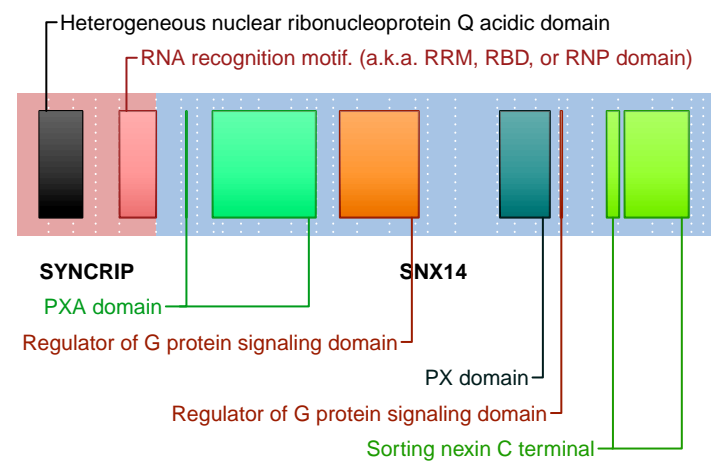

SUPPORTING READ COUNT

Split reads = 159
Discordant mates = 8

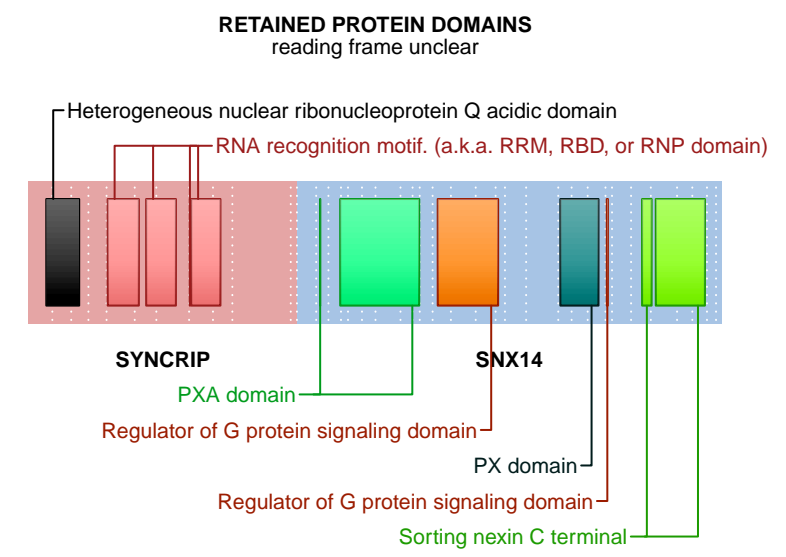
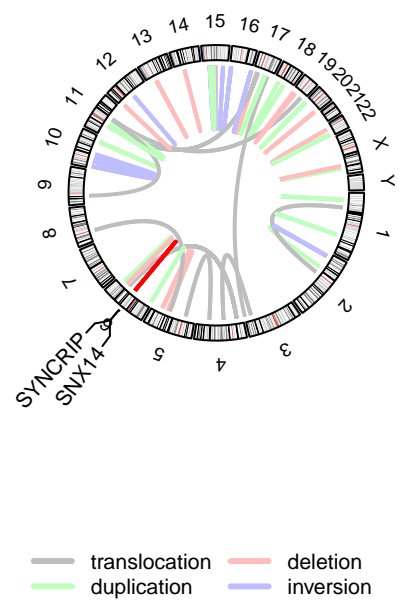
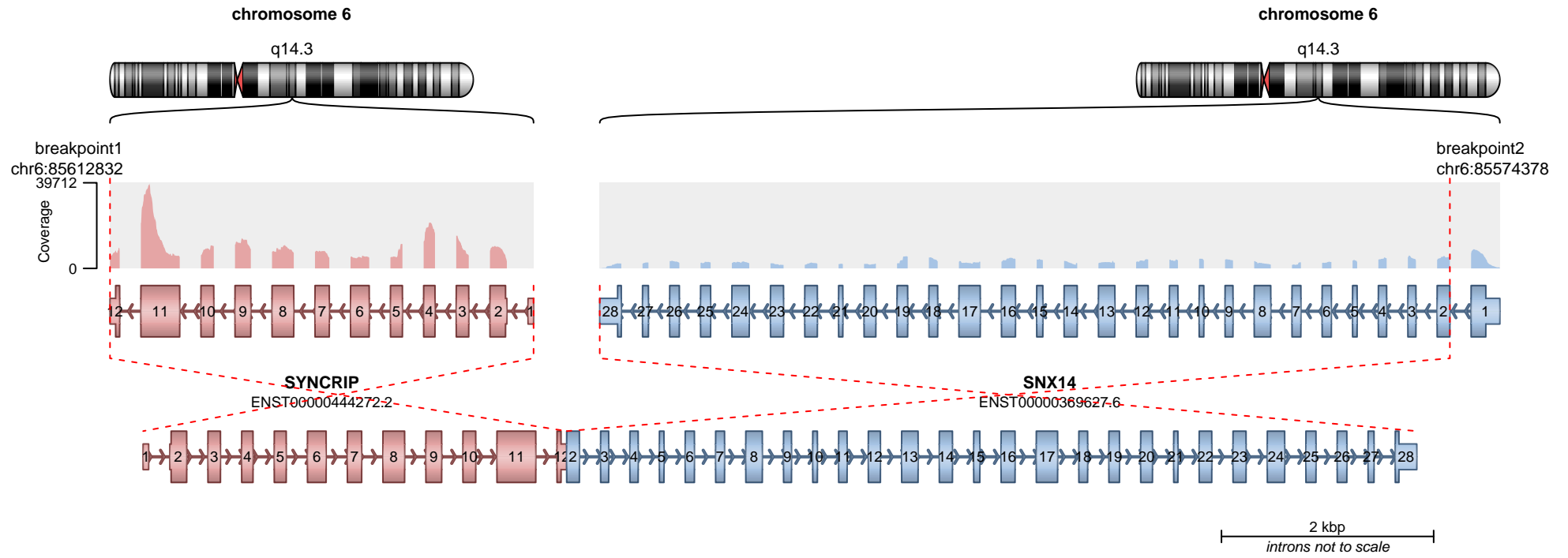

SUPPORTING READ COUNT

Split reads = 66
Discordant mates = 14

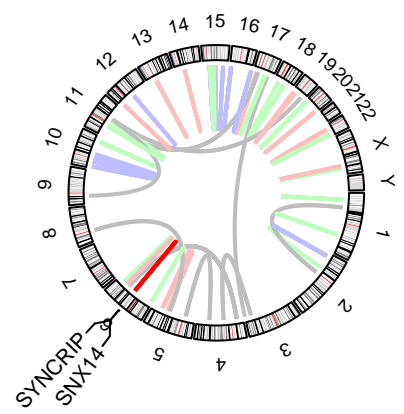
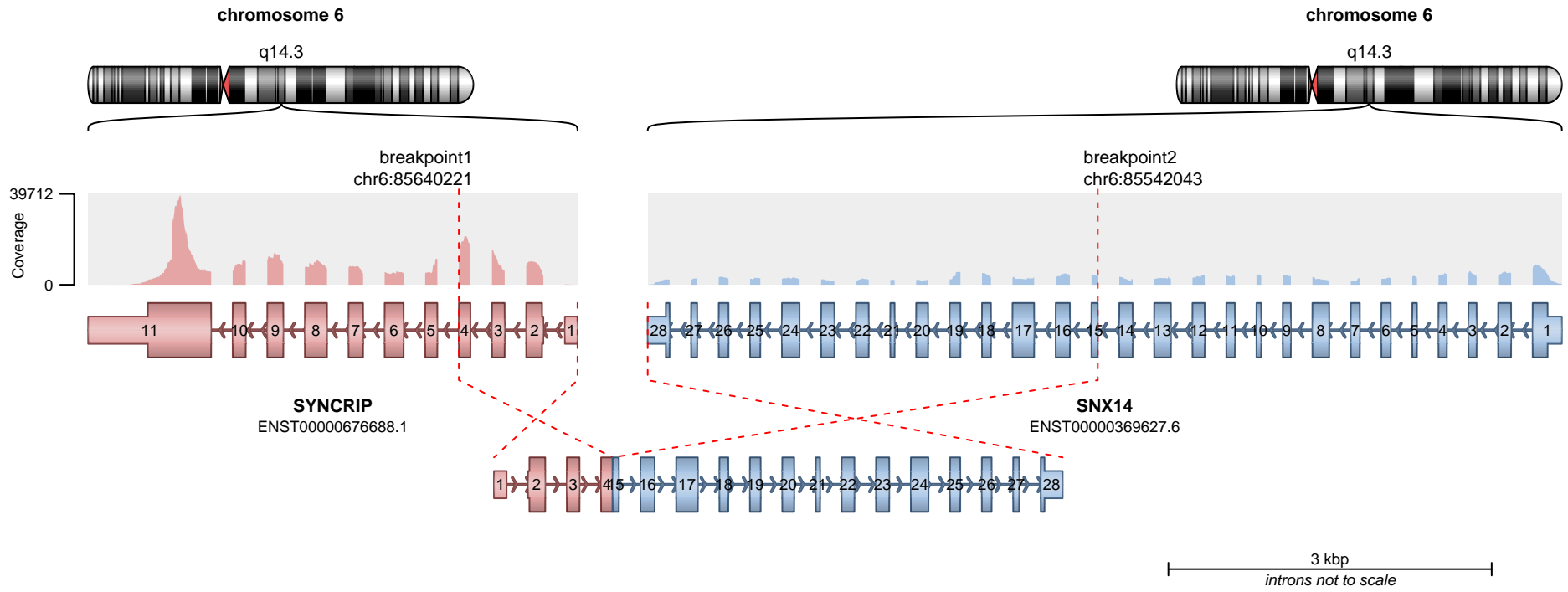

— translocation — deletion
— duplication — inversion

RETAINED PROTEIN DOMAINS
reading frame unclear

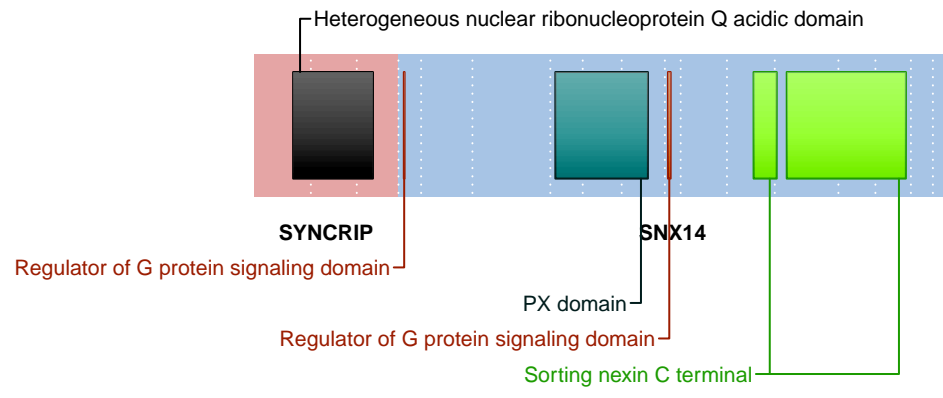

SUPPORTING READ COUNT

Split reads = 1
Discordant mates = 0

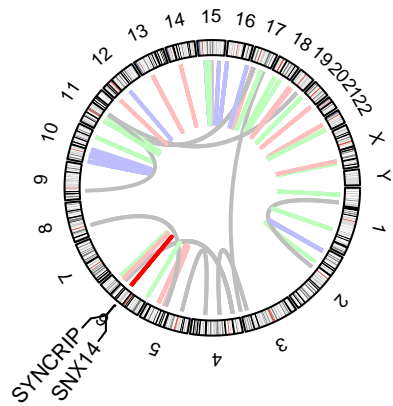
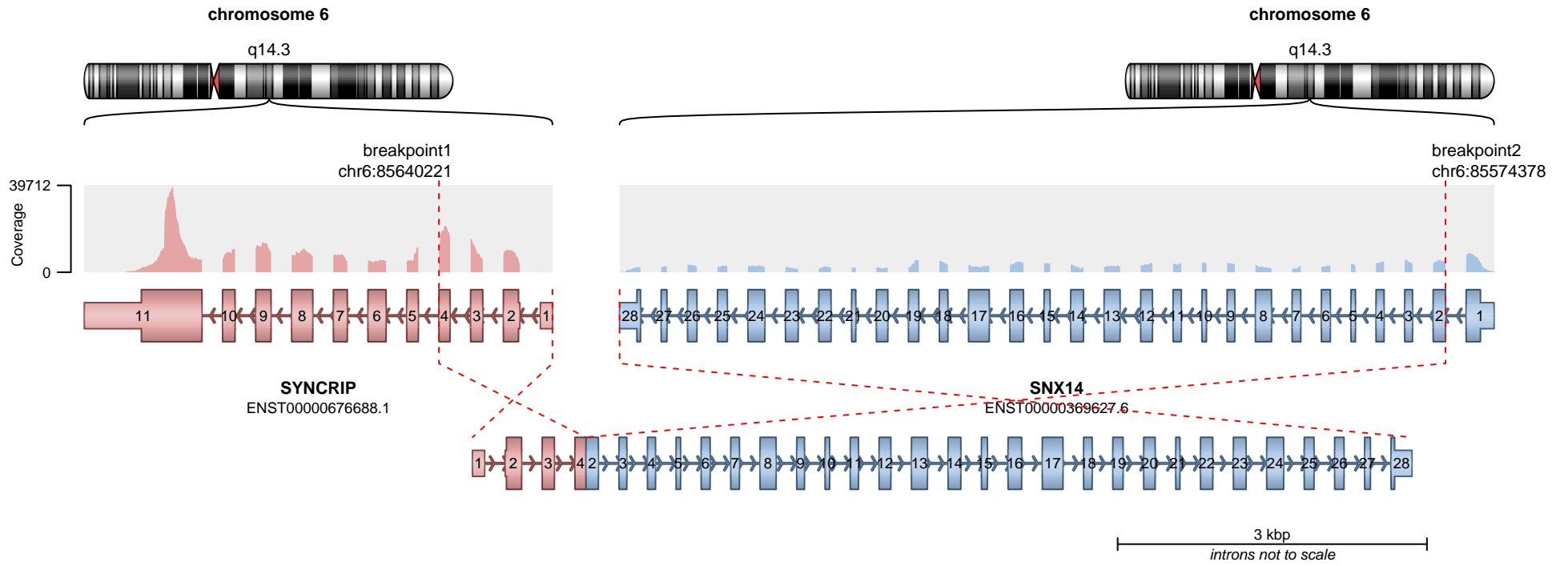

— translocation — deletion
— duplication — inversion

RETAINED PROTEIN DOMAINS
reading frame unclear

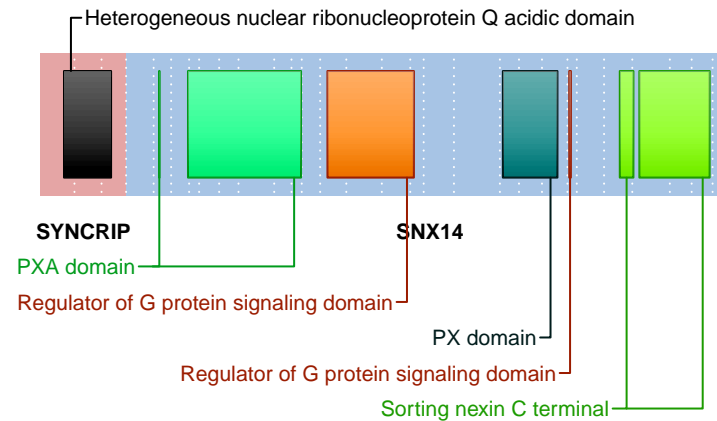

SUPPORTING READ COUNT

Split reads = 1
Discordant mates = 0

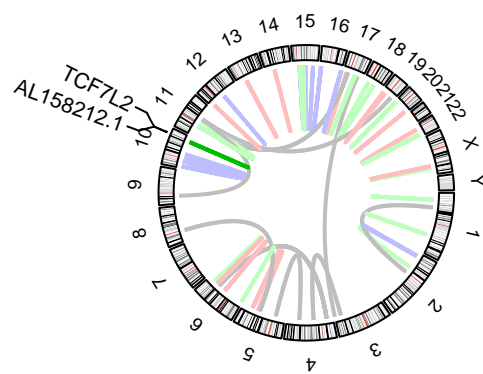
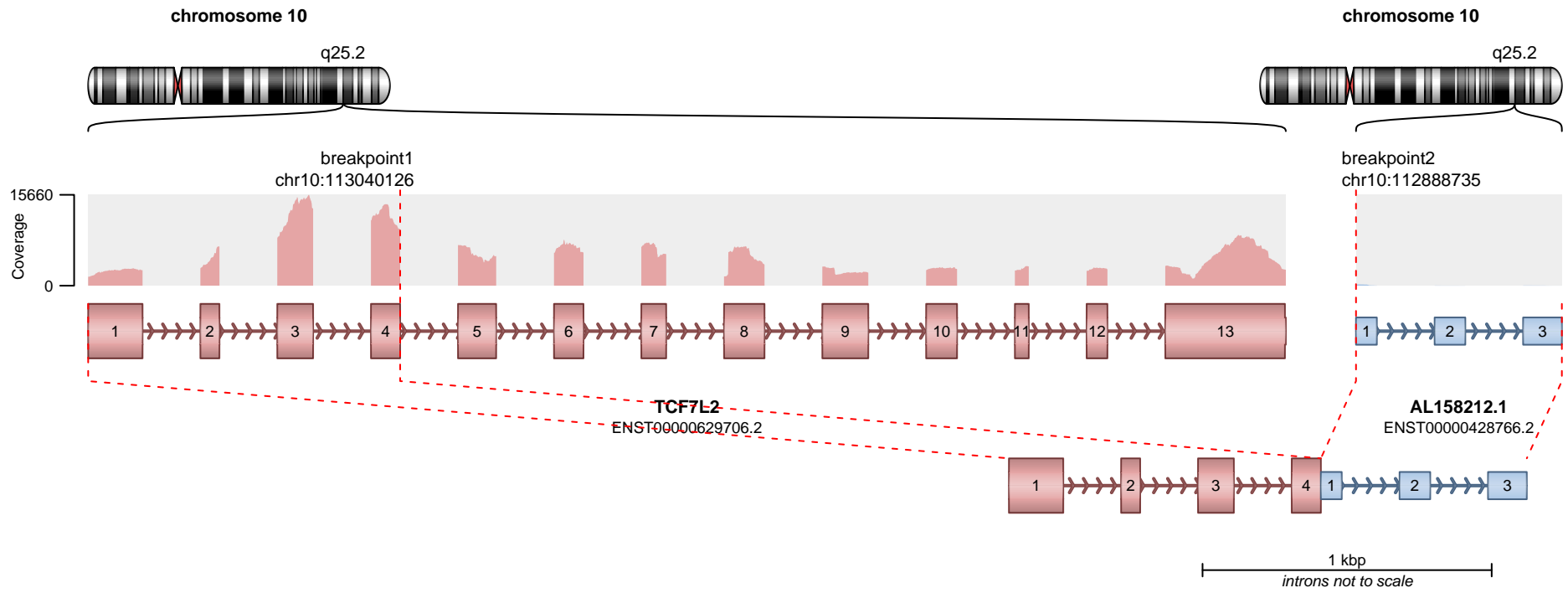

RETAINED PROTEIN DOMAINS
reading frame unclear

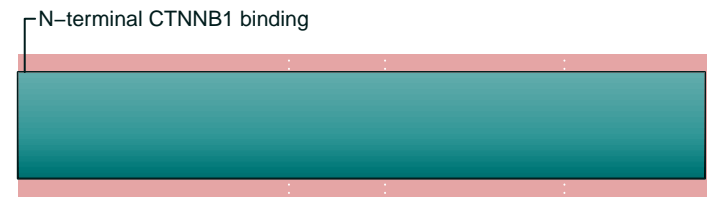

SUPPORTING READ COUNT

Split reads = 115
Discordant mates = 1

- translocation
- duplication
- deletion
- inversion

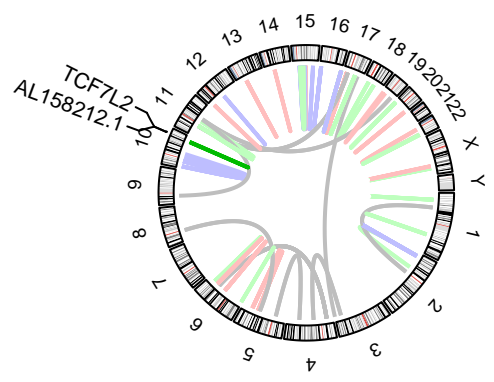
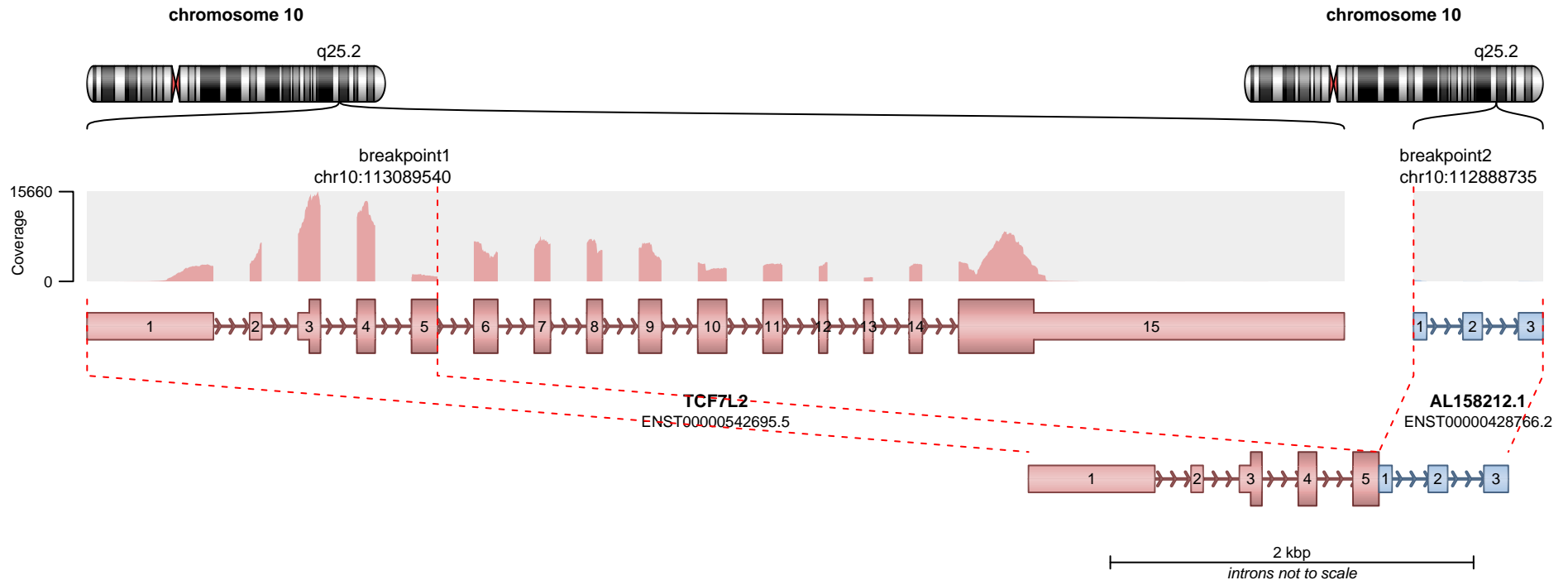

RETAINED PROTEIN DOMAINS
reading frame unclear

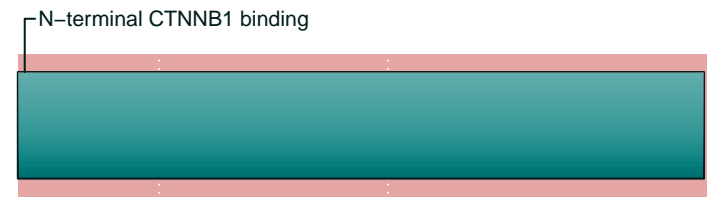

TCF7L2

SUPPORTING READ COUNT

Split reads = 19
Discordant mates = 1

- translocation
- duplication
- deletion
- inversion

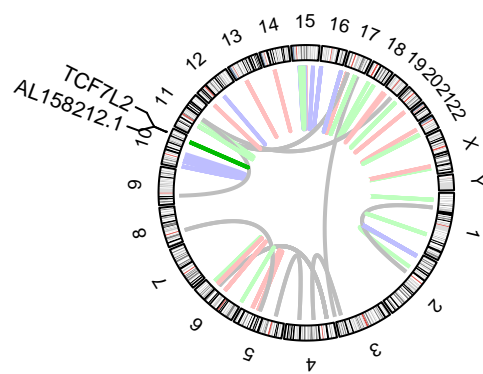
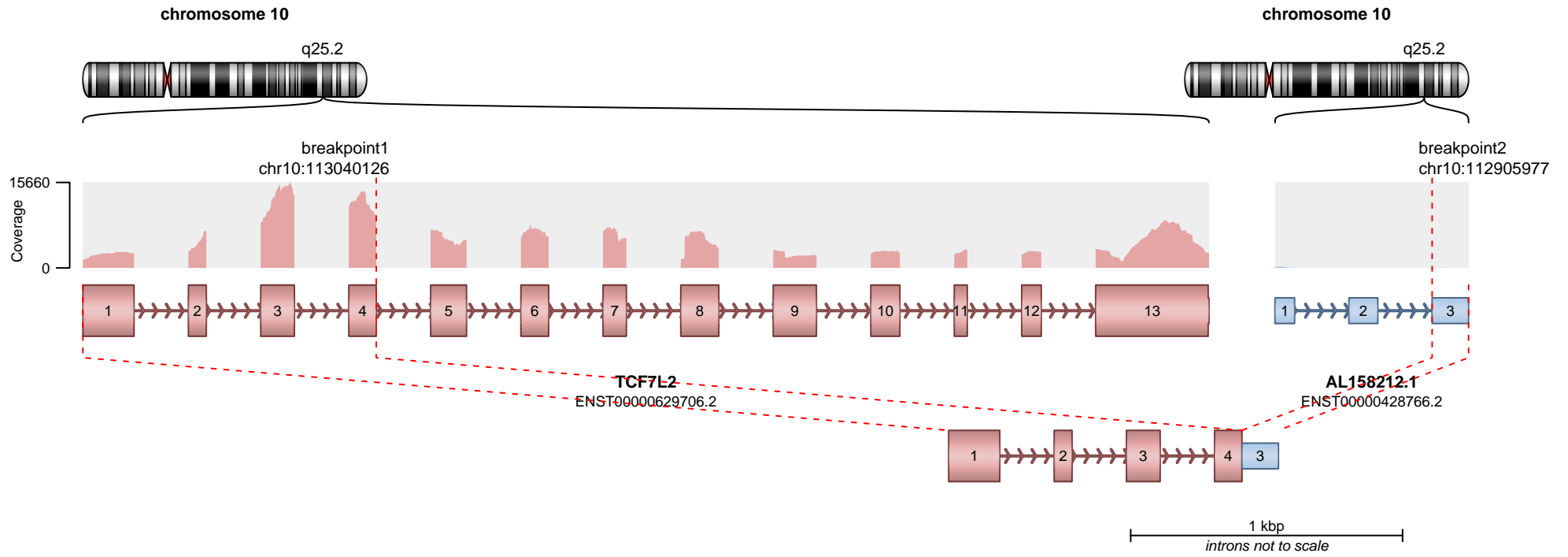

RETAINED PROTEIN DOMAINS
reading frame unclear

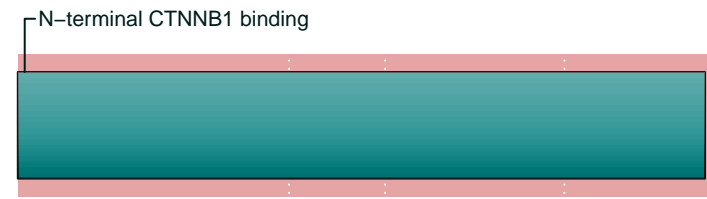

SUPPORTING READ COUNT

Split reads = 10
Discordant mates = 1

- translocation
- duplication
- deletion
- inversion

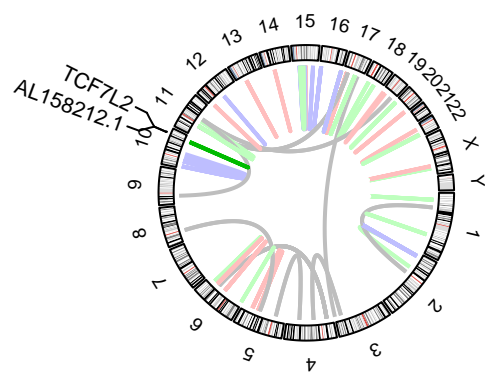
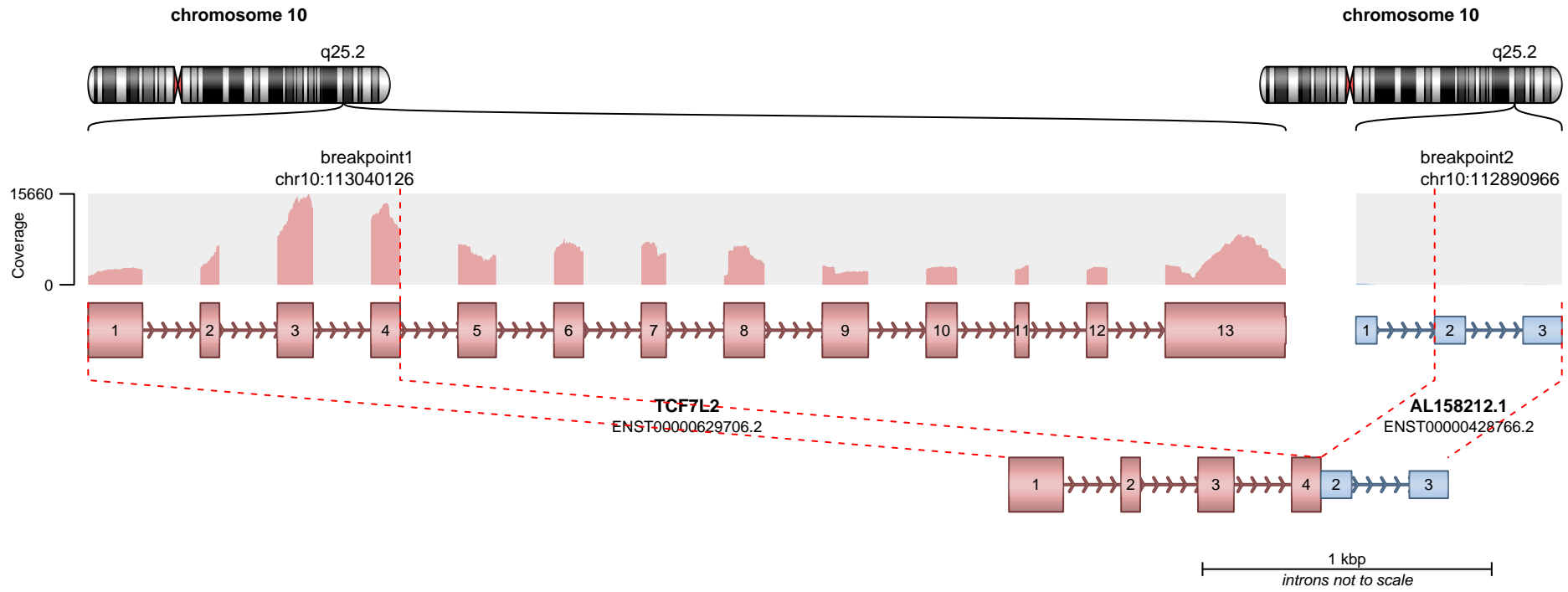

RETAINED PROTEIN DOMAINS
reading frame unclear

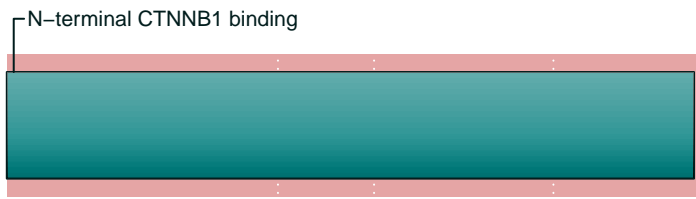

SUPPORTING READ COUNT

Split reads = 6
Discordant mates = 1

- translocation
- duplication
- deletion
- inversion

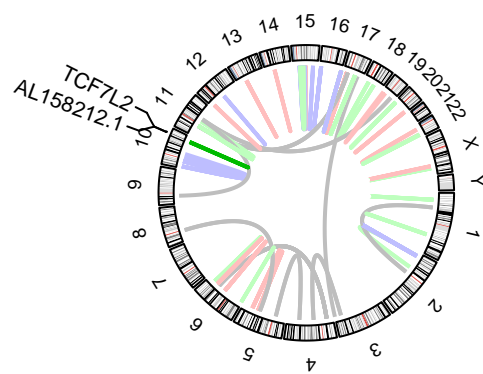
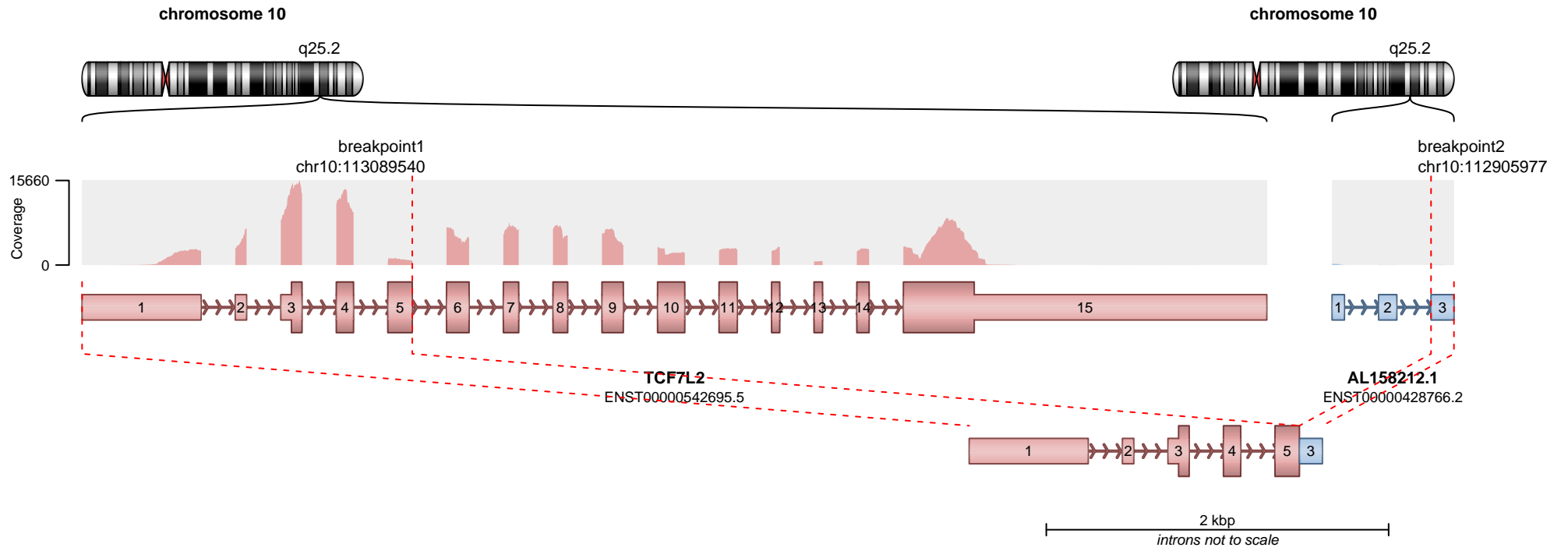

RETAINED PROTEIN DOMAINS
reading frame unclear

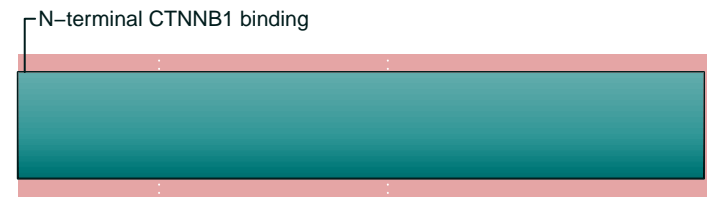

SUPPORTING READ COUNT

Split reads = 2
Discordant mates = 1

- translocation
- duplication
- deletion
- inversion

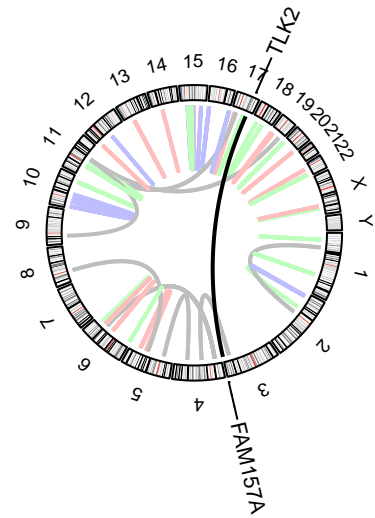
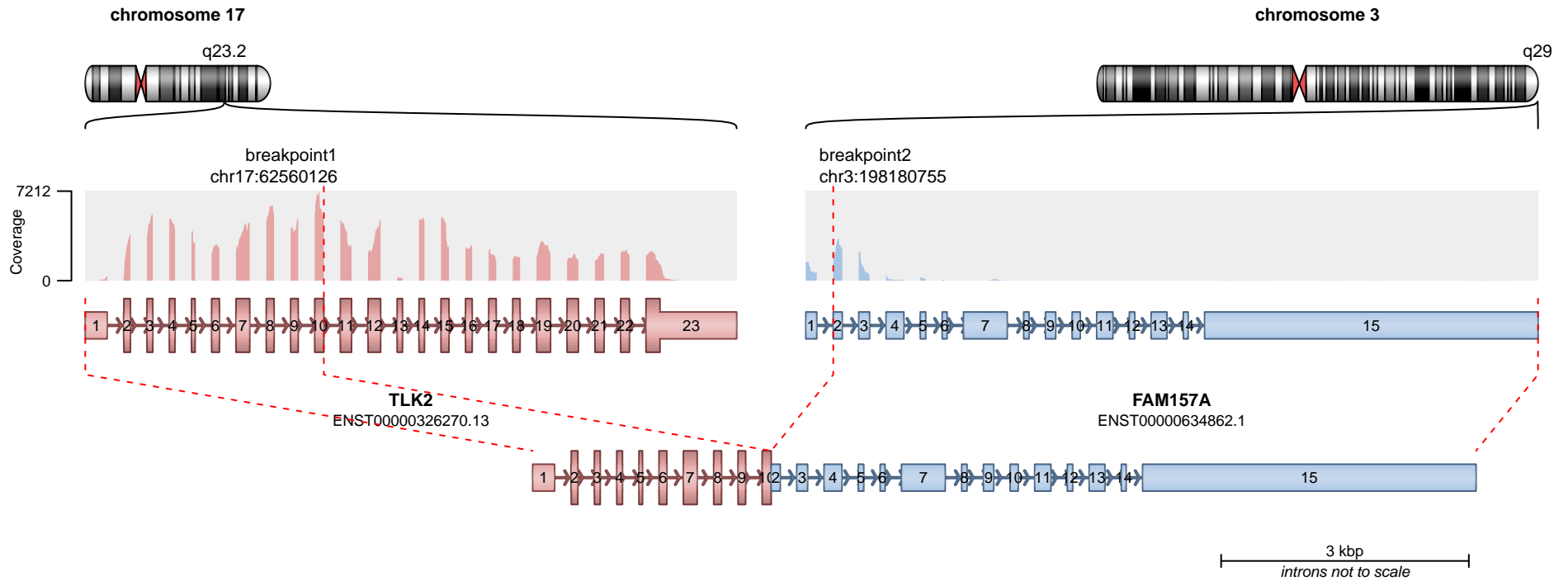

— translocation — deletion
— duplication — inversion

No protein domains retained in fusion.

SUPPORTING READ COUNT

Split reads = 115
Discordant mates = 1

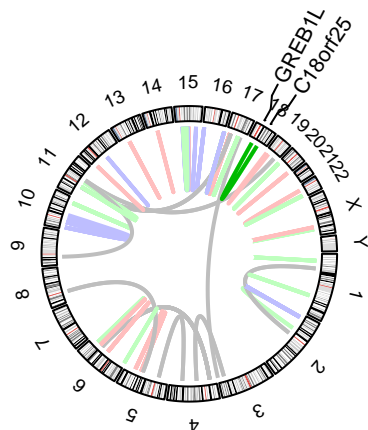
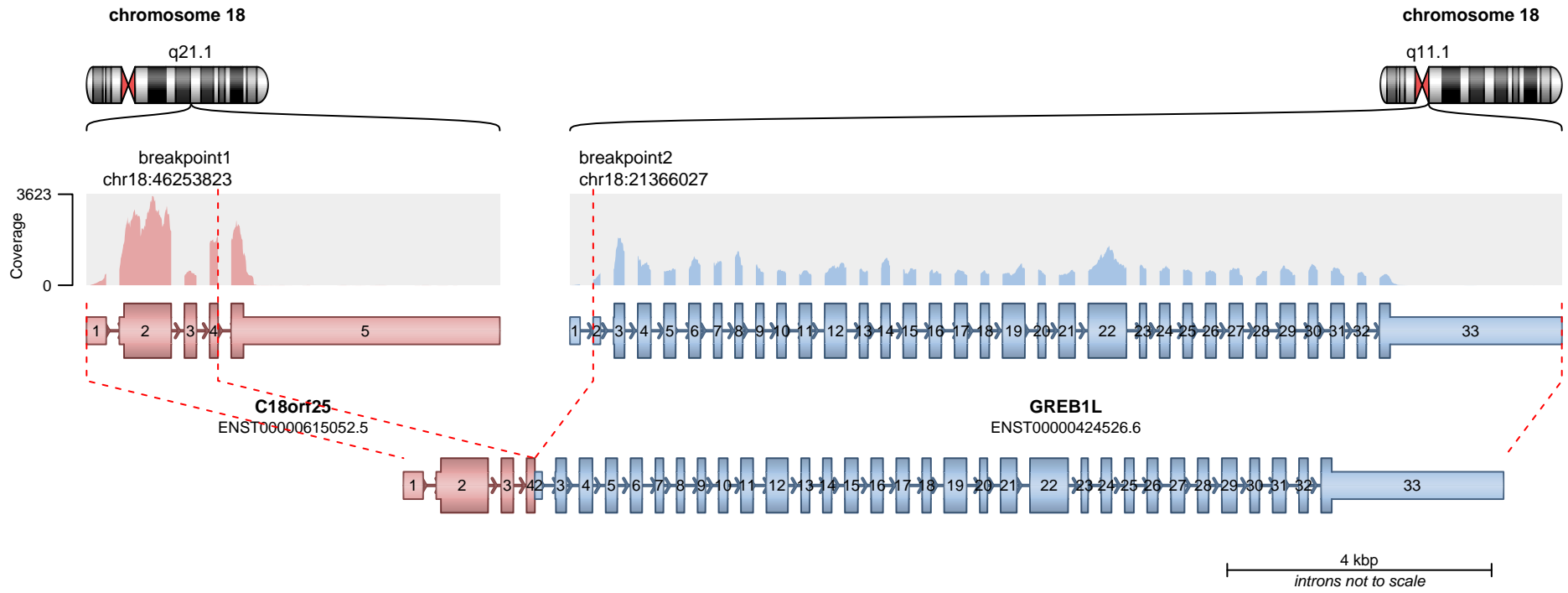

RETAINED PROTEIN DOMAINS
reading frame unclear

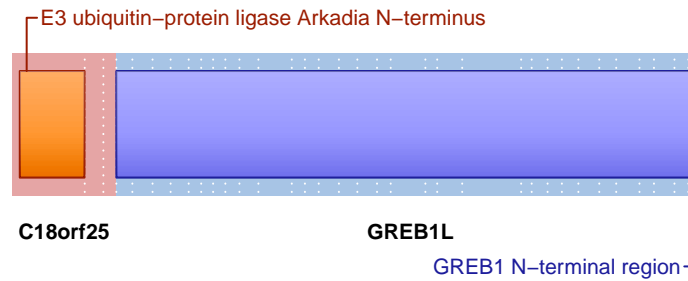

SUPPORTING READ COUNT

Split reads = 109
Discordant mates = 7

— translocation — deletion
— duplication — inversion

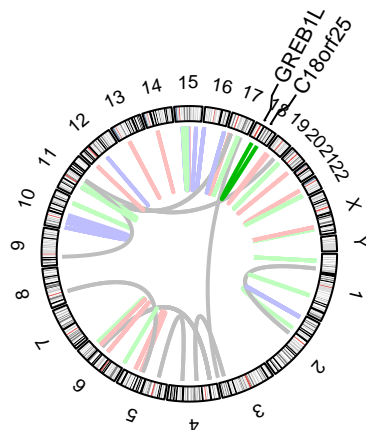
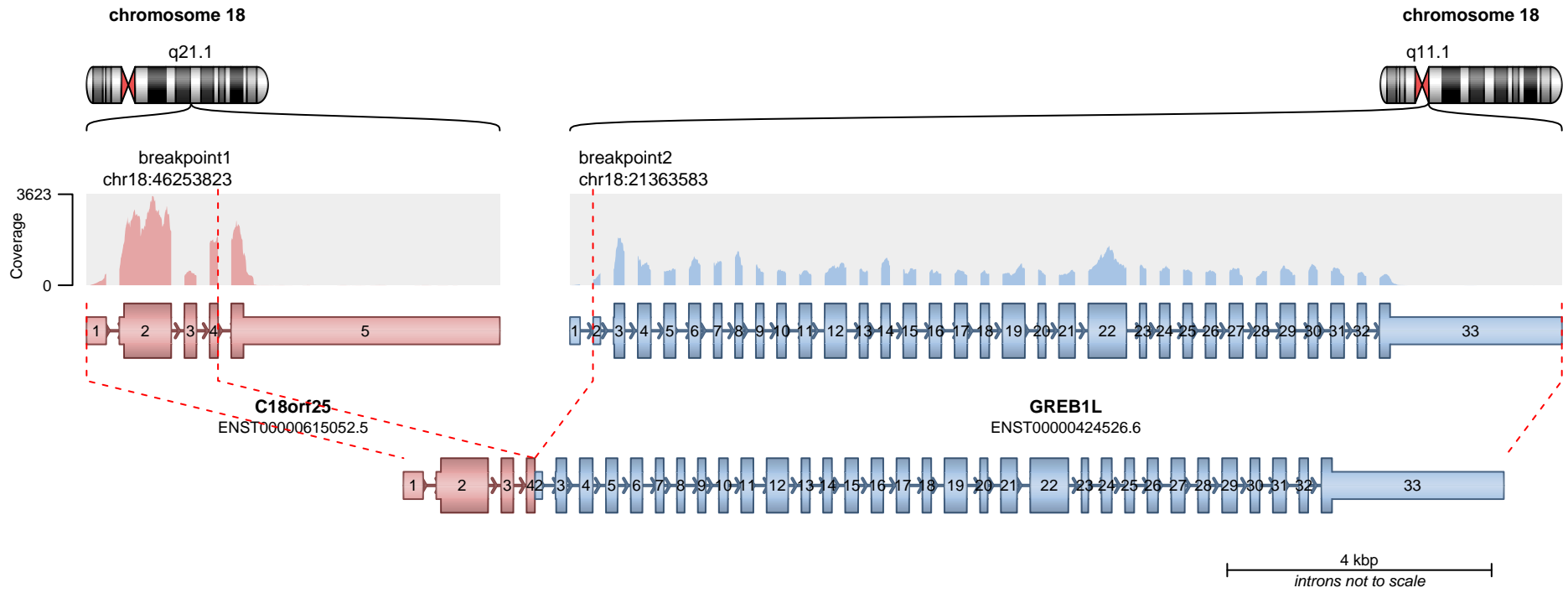

RETAINED PROTEIN DOMAINS
reading frame unclear

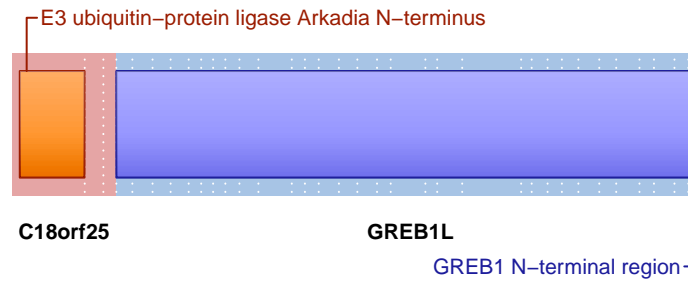

SUPPORTING READ COUNT

Split reads = 4
Discordant mates = 7

— translocation — deletion
— duplication — inversion

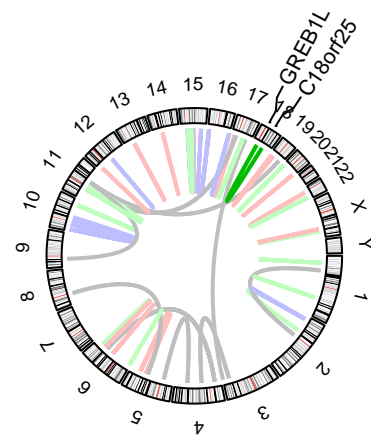
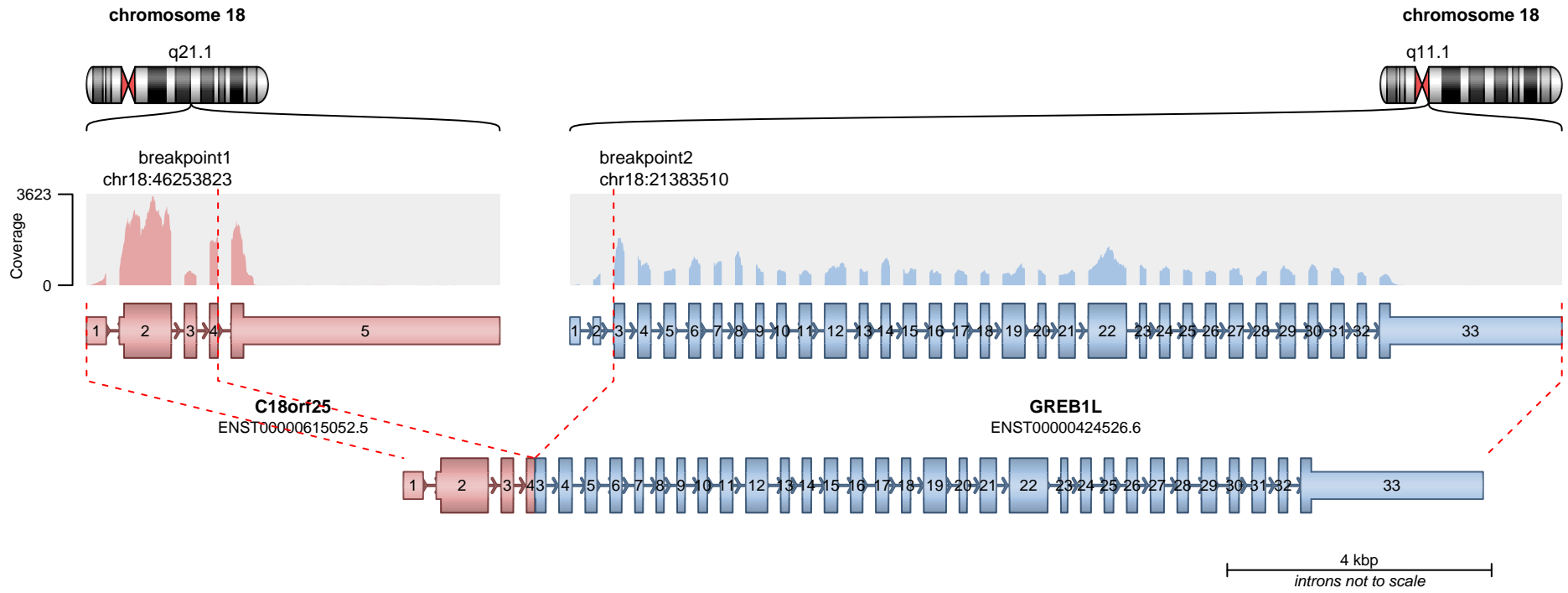

RETAINED PROTEIN DOMAINS
reading frame unclear

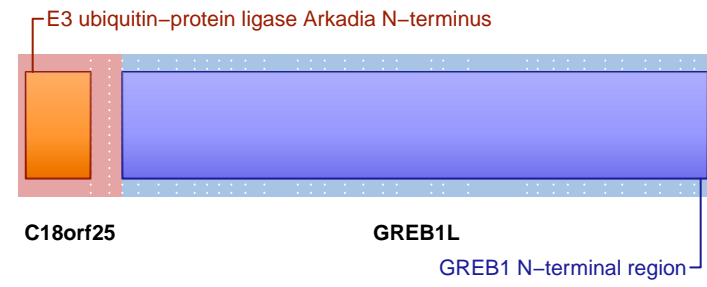

SUPPORTING READ COUNT

Split reads = 3
Discordant mates = 2

- translocation
- duplication
- deletion
- inversion

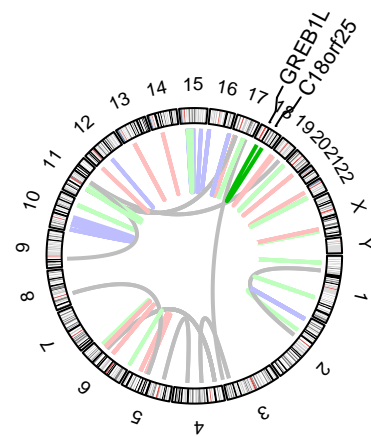
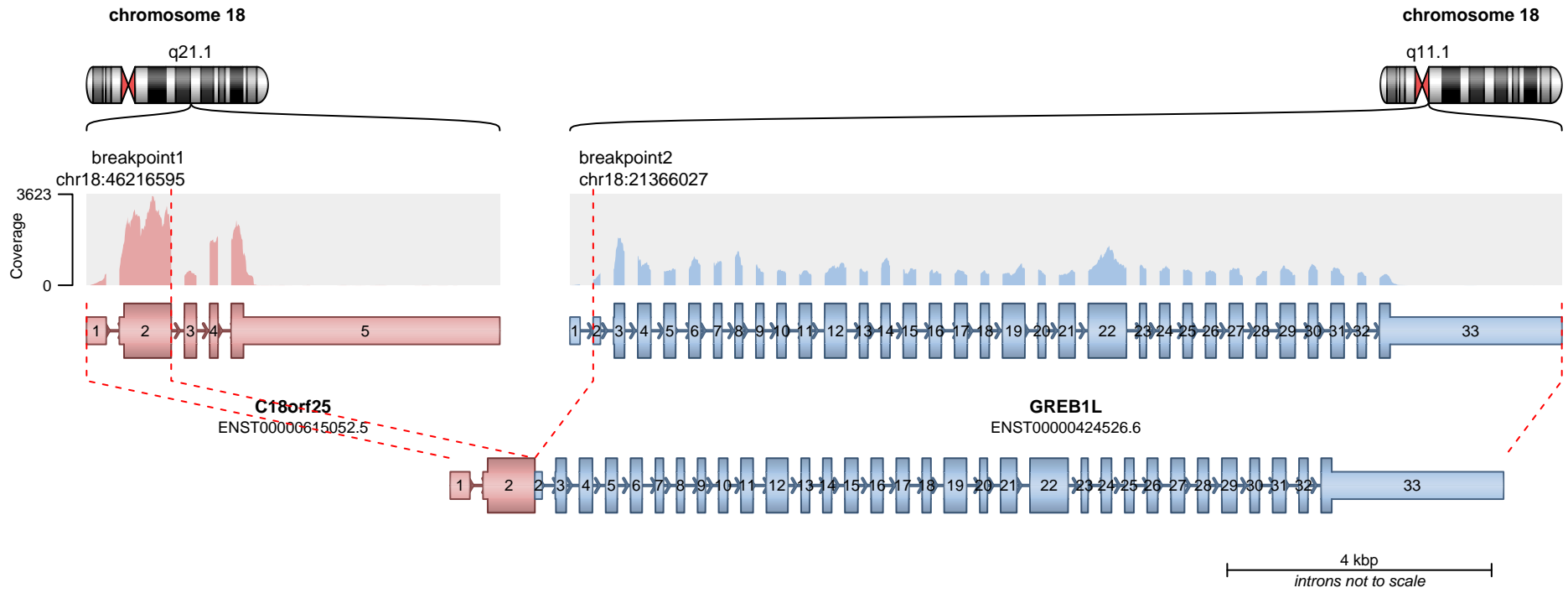

RETAINED PROTEIN DOMAINS
reading frame unclear

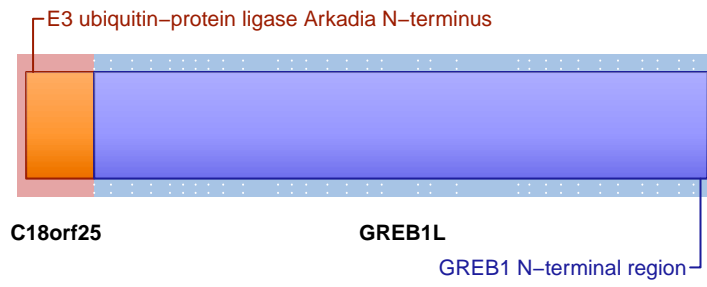

SUPPORTING READ COUNT

Split reads = 1
Discordant mates = 3

- translocation
- duplication
- deletion
- inversion

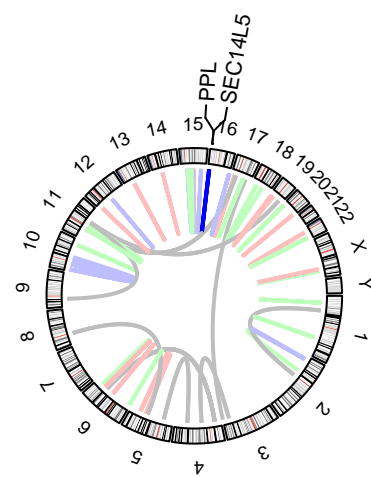
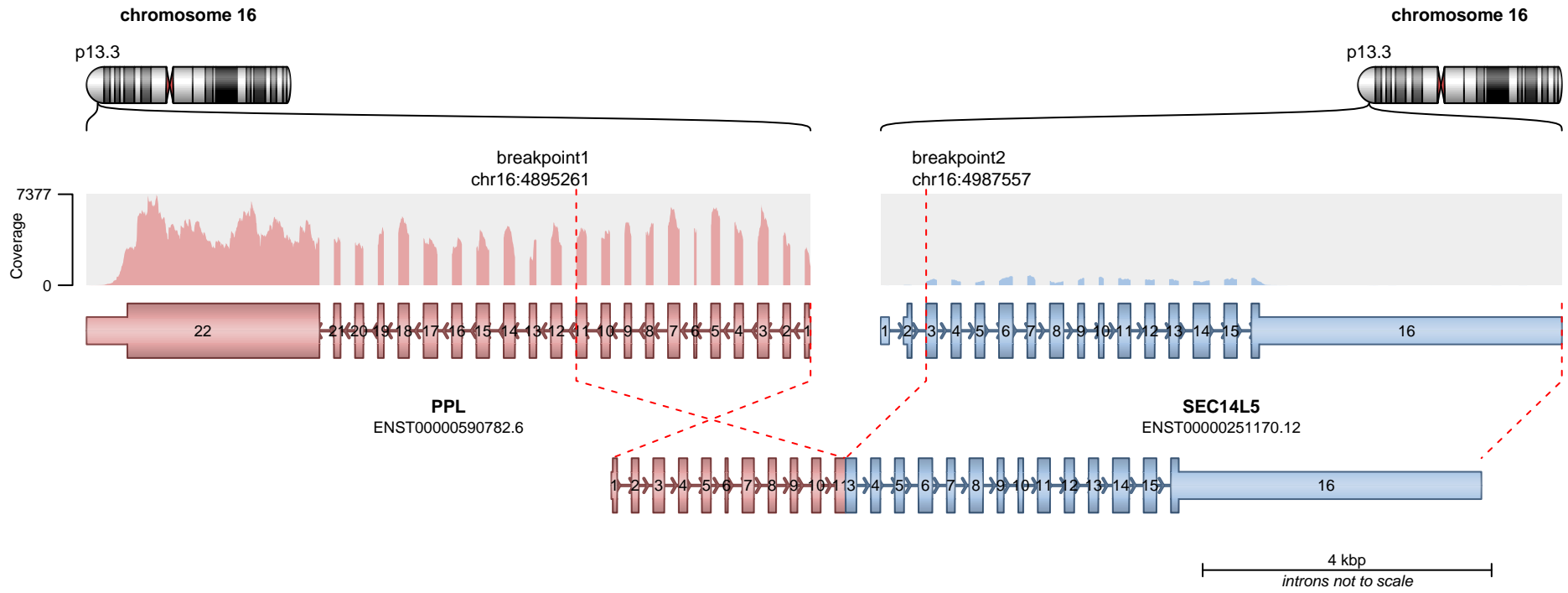

RETAINED PROTEIN DOMAINS
reading frame unclear

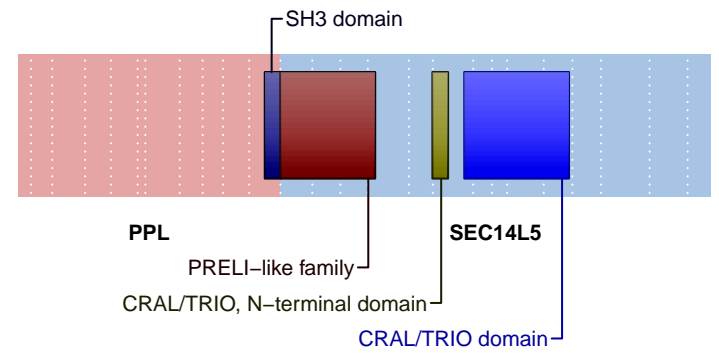

SUPPORTING READ COUNT

Split reads = 102
Discordant mates = 7

- translocation
- duplication
- deletion
- inversion

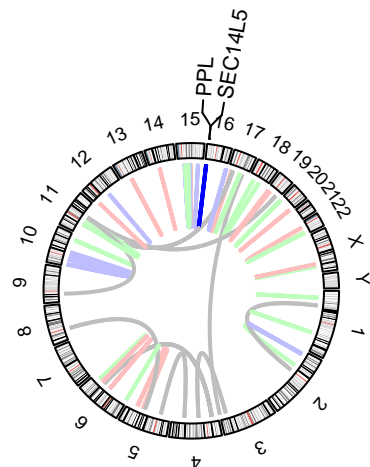
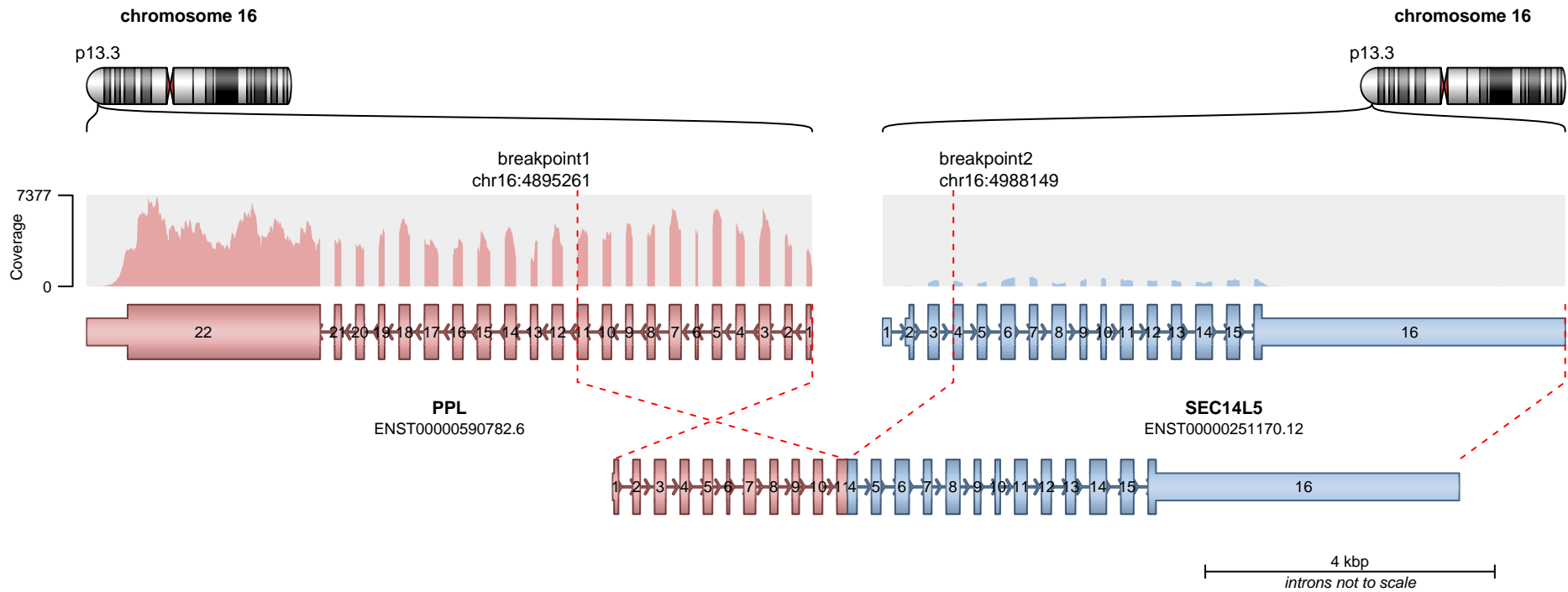

RETAINED PROTEIN DOMAINS
reading frame unclear

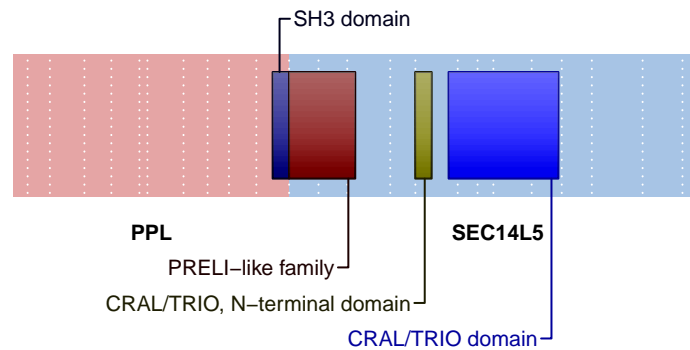

SUPPORTING READ COUNT

Split reads = 4
Discordant mates = 1

— translocation — deletion
— duplication — inversion

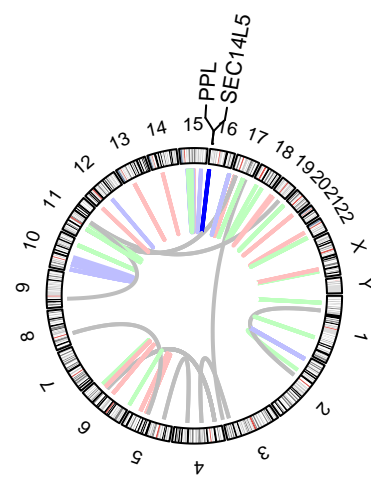
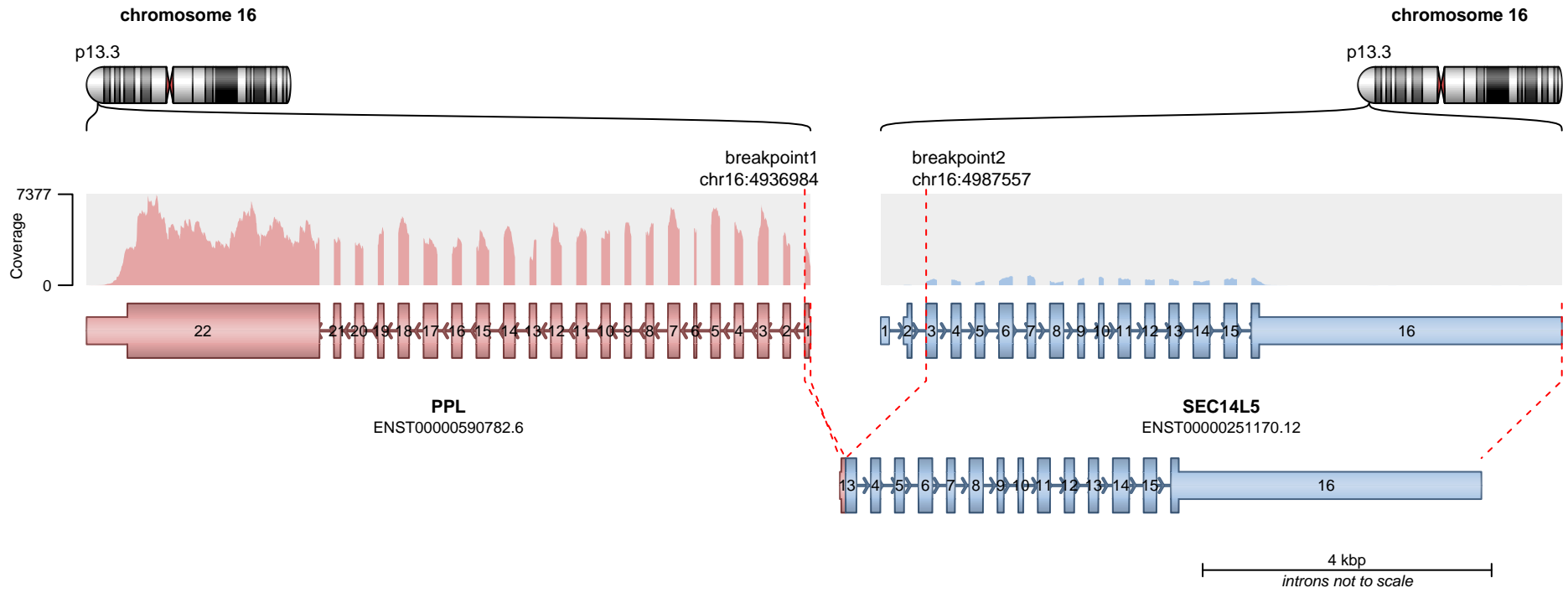

RETAINED PROTEIN DOMAINS
reading frame unclear

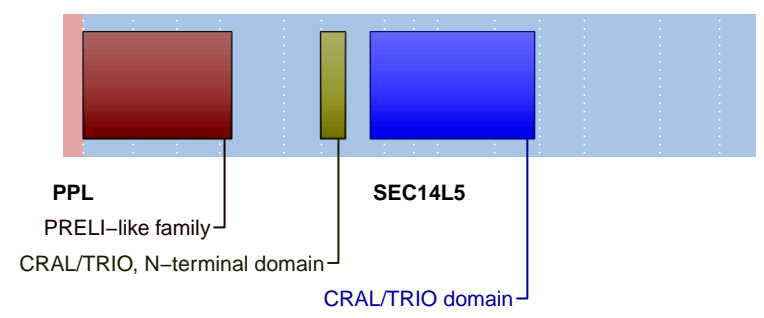

SUPPORTING READ COUNT

Split reads = 1
Discordant mates = 0

— translocation — deletion
— duplication — inversion

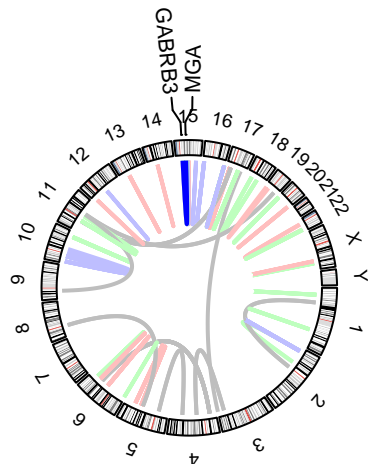
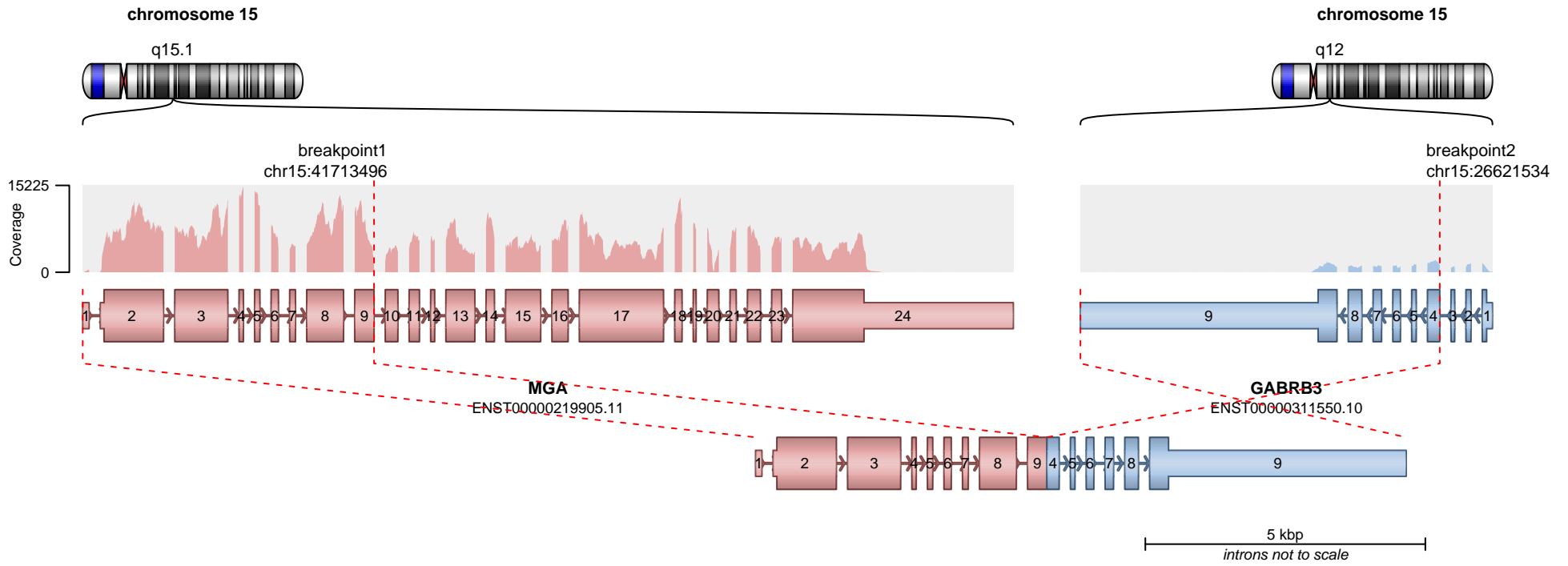

RETAINED PROTEIN DOMAINS
reading frame unclear

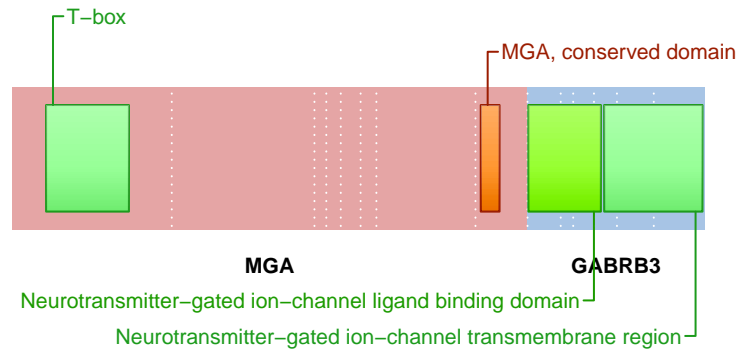

SUPPORTING READ COUNT

Split reads = 92
Discordant mates = 4

— translocation — deletion
— duplication — inversion

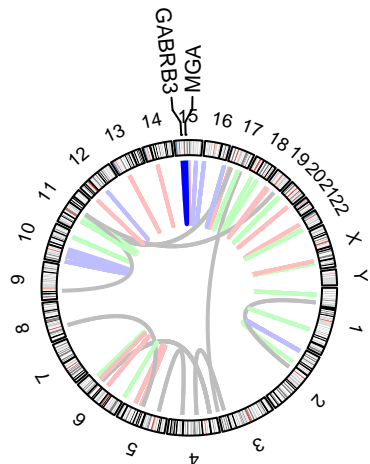
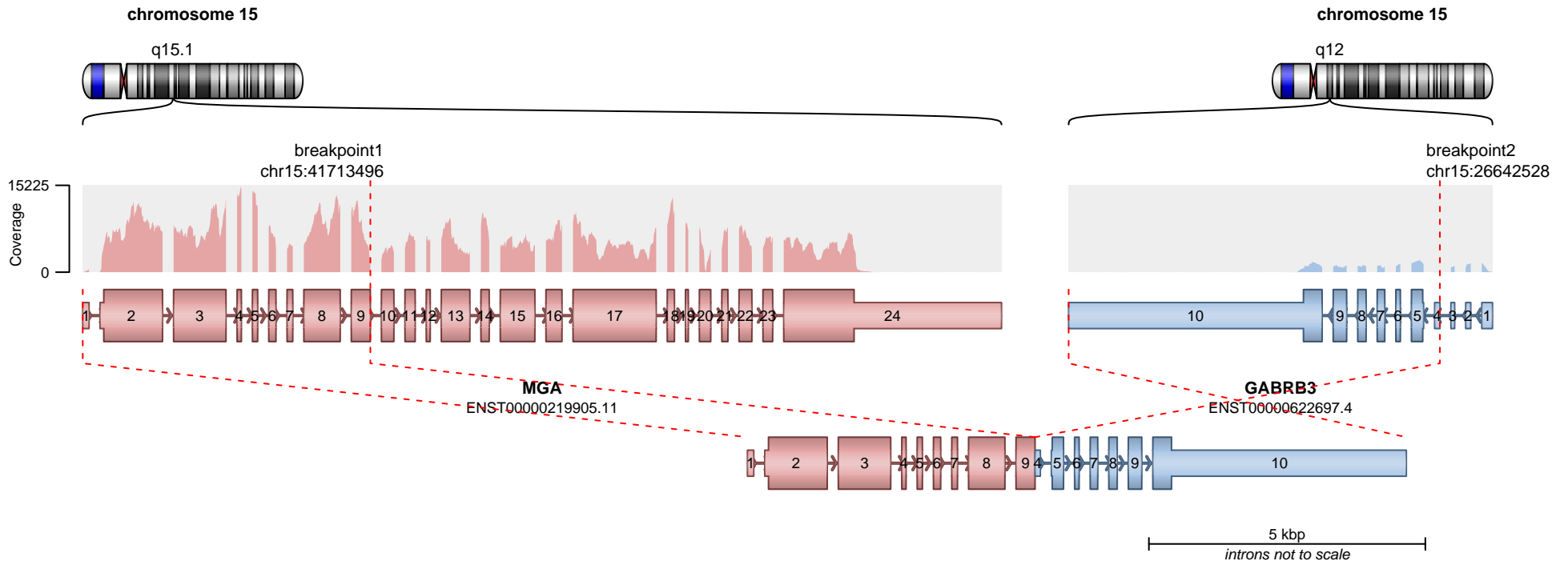

RETAINED PROTEIN DOMAINS
reading frame unclear

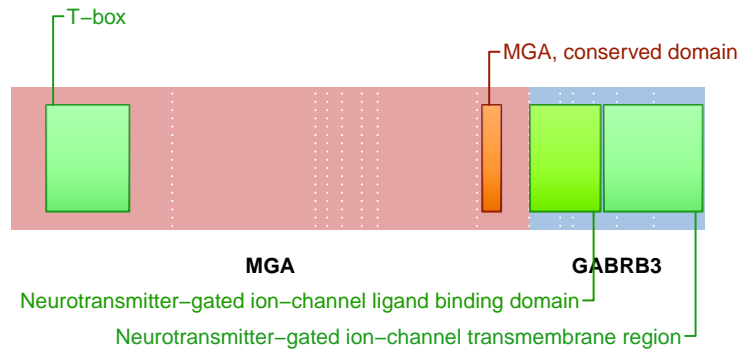

SUPPORTING READ COUNT

Split reads = 17
Discordant mates = 10

— translocation — deletion
— duplication — inversion

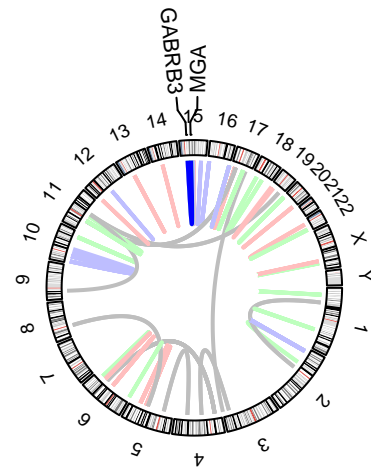
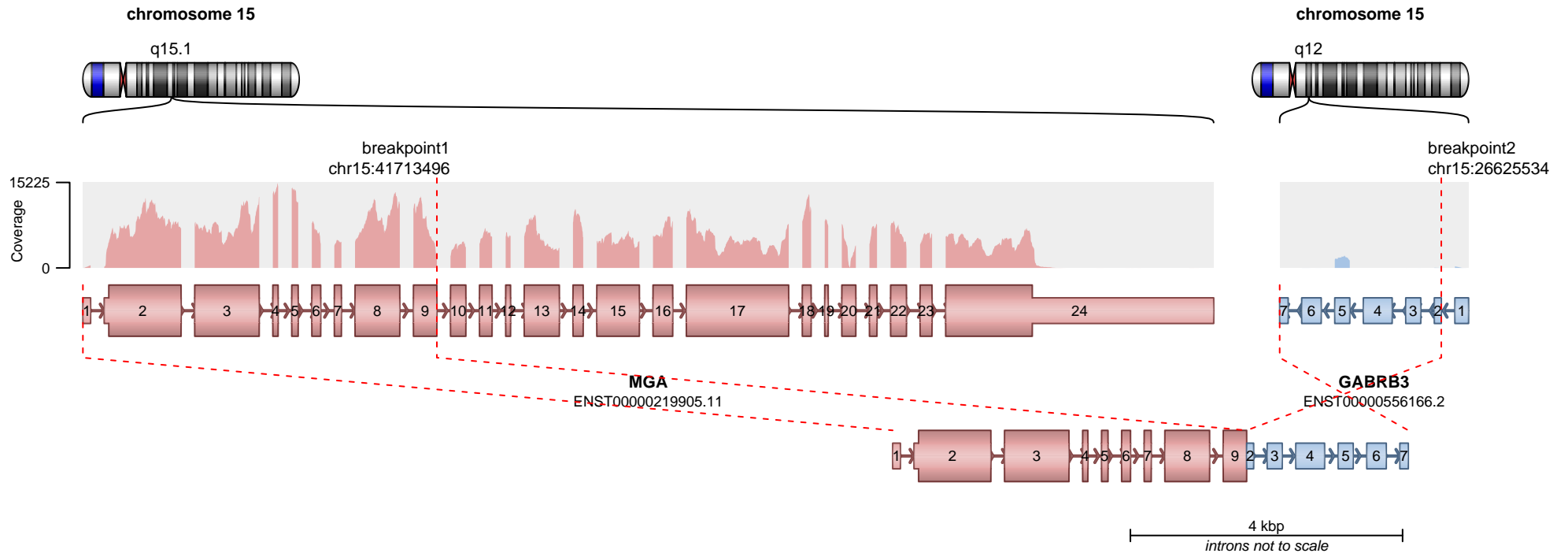

RETAINED PROTEIN DOMAINS
reading frame unclear

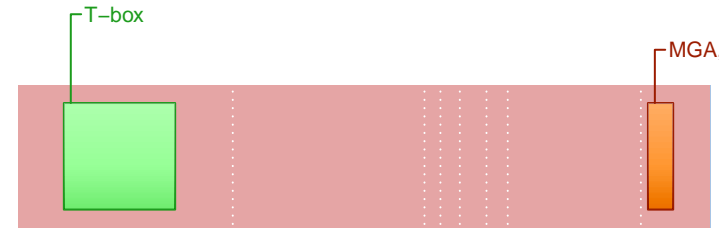

SUPPORTING READ COUNT

Split reads = 4
Discordant mates = 4

- translocation
- duplication
- deletion
- inversion

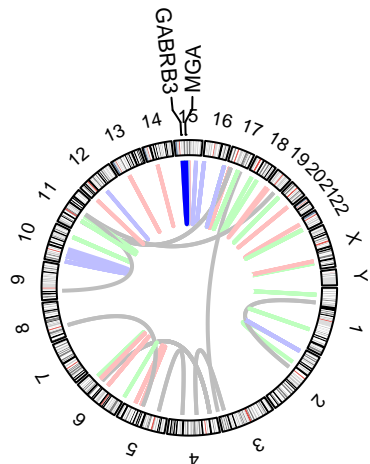
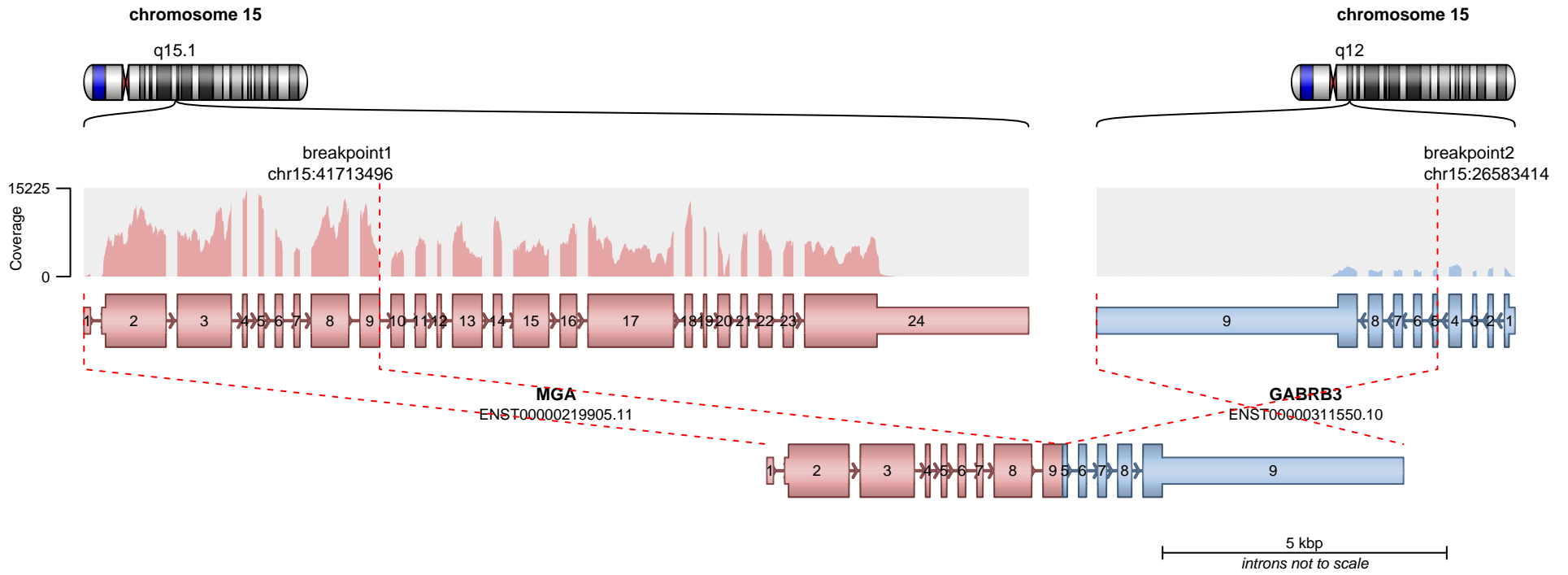

RETAINED PROTEIN DOMAINS
reading frame unclear

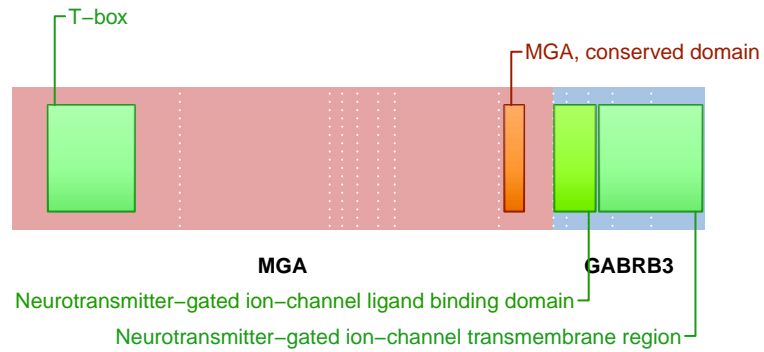

SUPPORTING READ COUNT

Split reads = 1
Discordant mates = 0

— translocation — deletion
— duplication — inversion

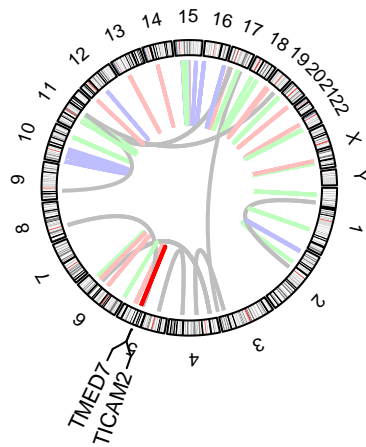
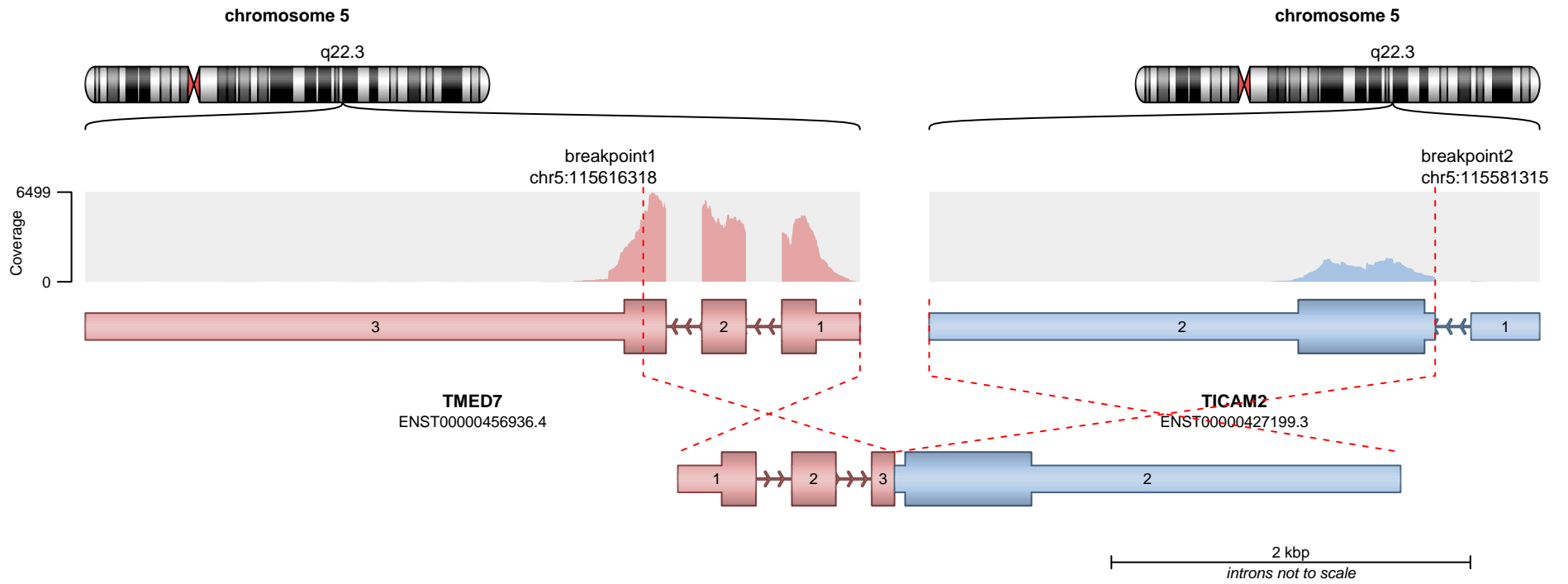

RETAINED PROTEIN DOMAINS
reading frame unclear

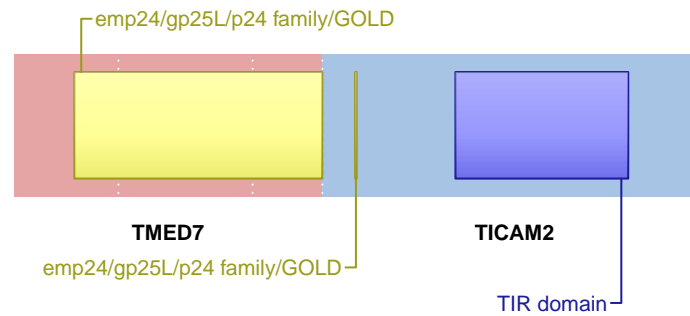

SUPPORTING READ COUNT

Split reads = 87
Discordant mates = 19

— translocation — deletion
— duplication — inversion

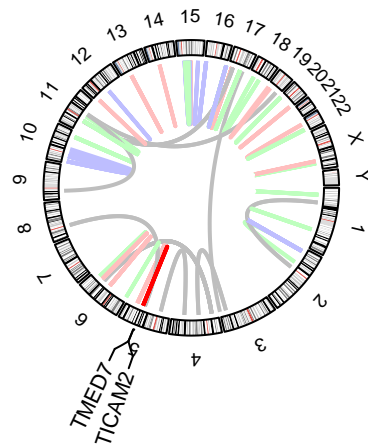
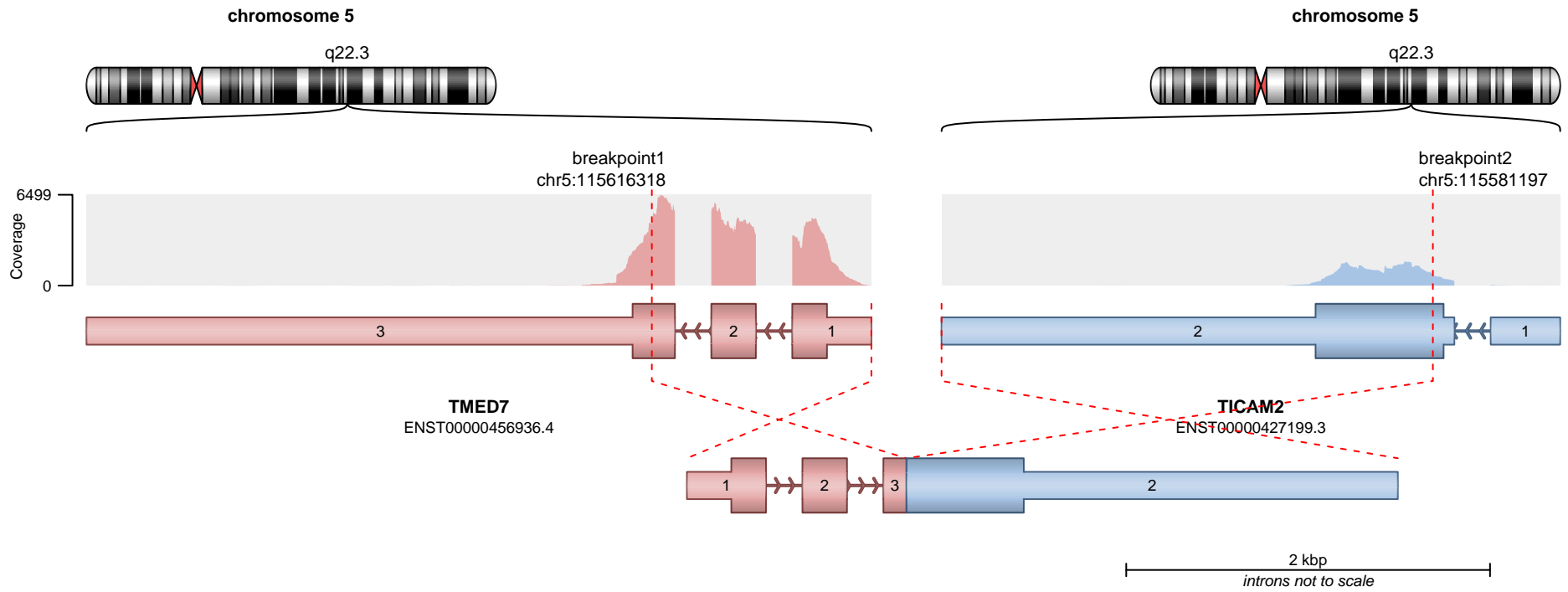

RETAINED PROTEIN DOMAINS
reading frame unclear

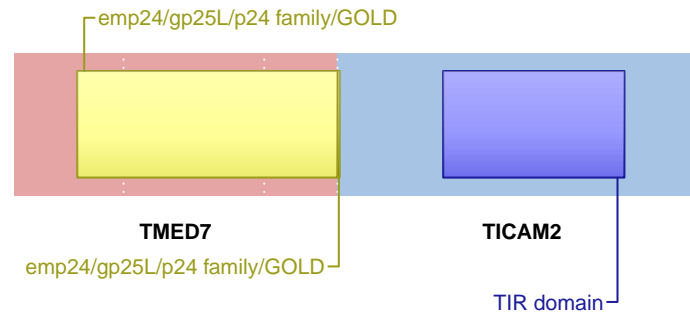

SUPPORTING READ COUNT

Split reads = 35
Discordant mates = 4

— translocation — deletion
— duplication — inversion

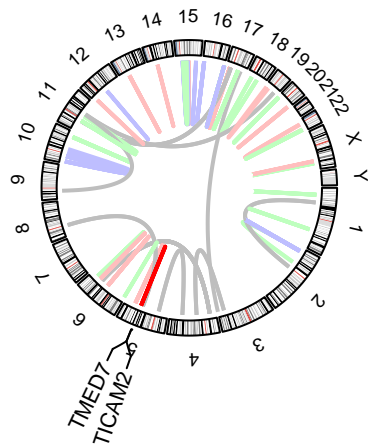
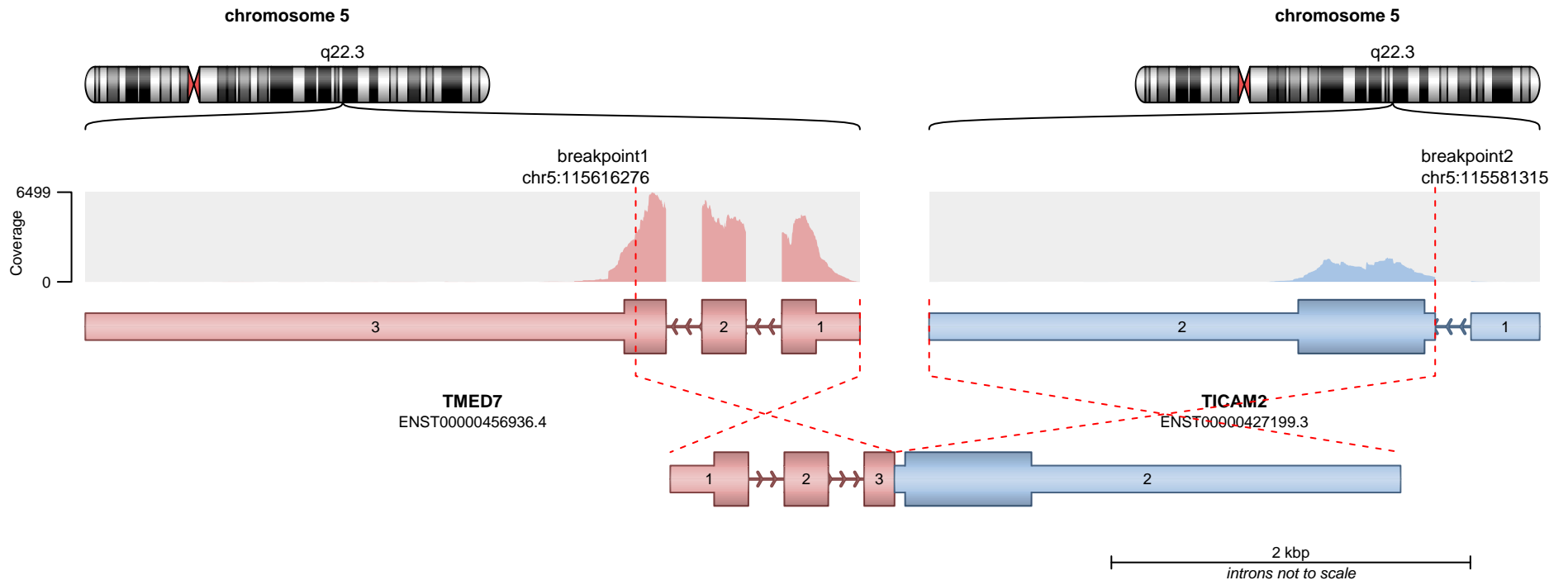

RETAINED PROTEIN DOMAINS
reading frame unclear

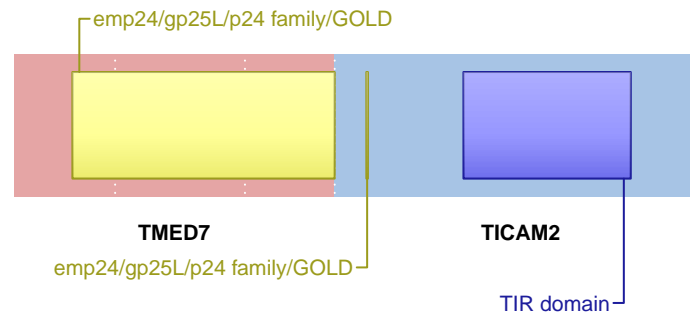

SUPPORTING READ COUNT

Split reads = 3
Discordant mates = 19

- translocation
- duplication
- deletion
- inversion

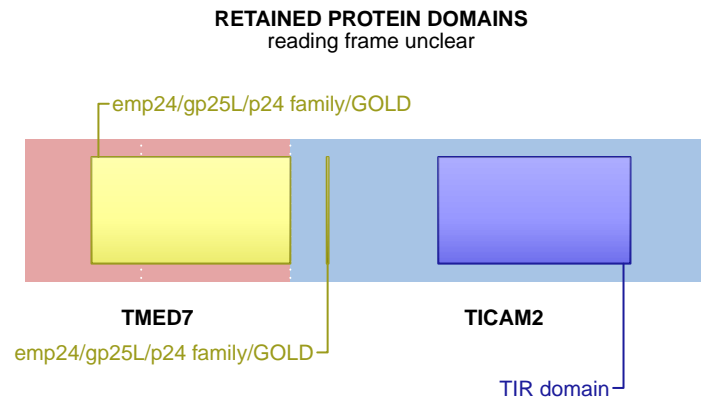
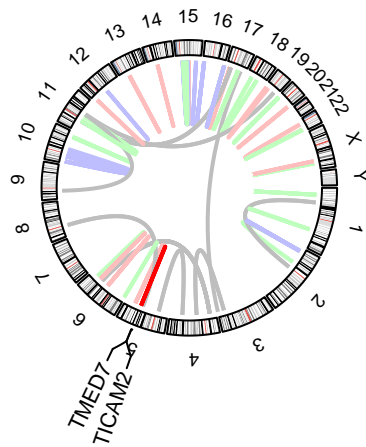
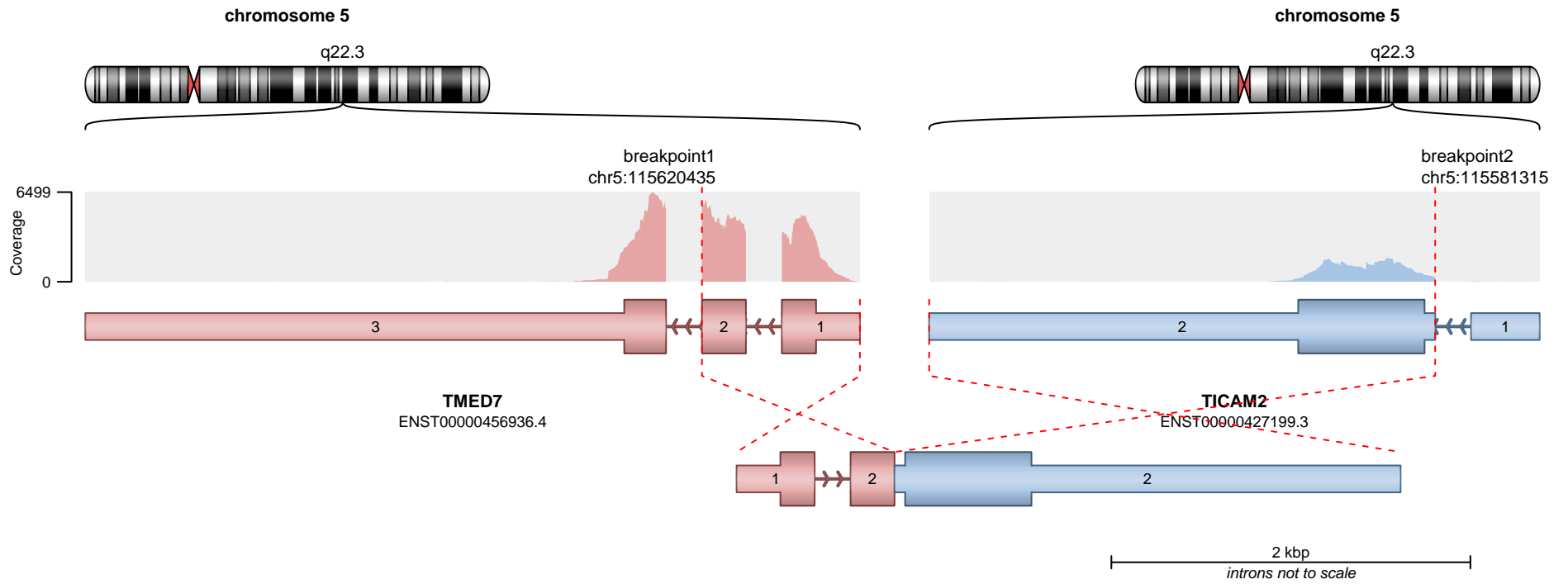

SUPPORTING READ COUNT

Split reads = 3
Discordant mates = 1

— translocation — deletion
— duplication — inversion

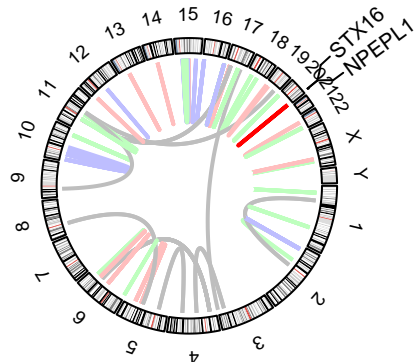
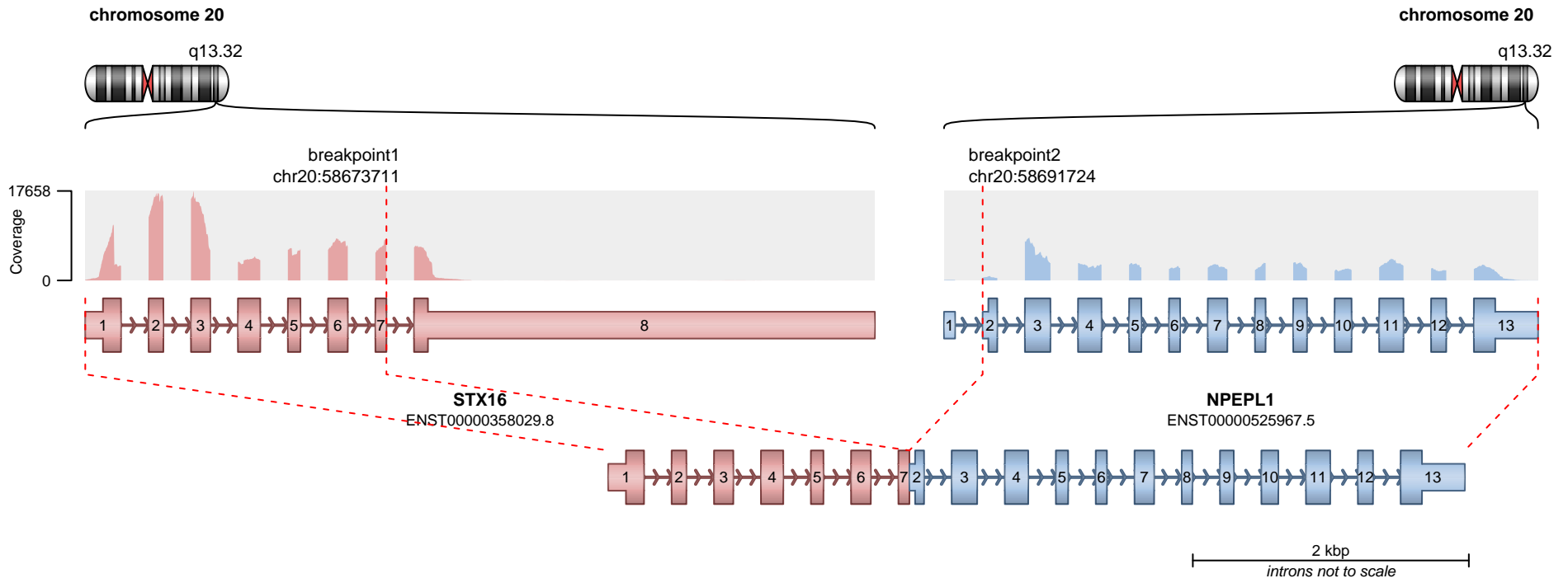

RETAINED PROTEIN DOMAINS
reading frame unclear

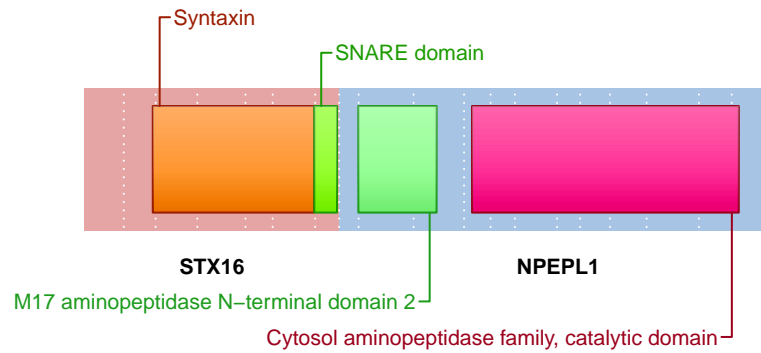

SUPPORTING READ COUNT

Split reads = 67
Discordant mates = 3

- translocation
- duplication
- deletion
- inversion

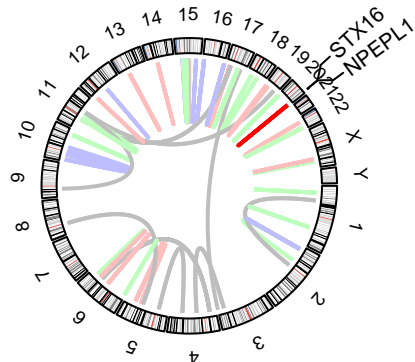
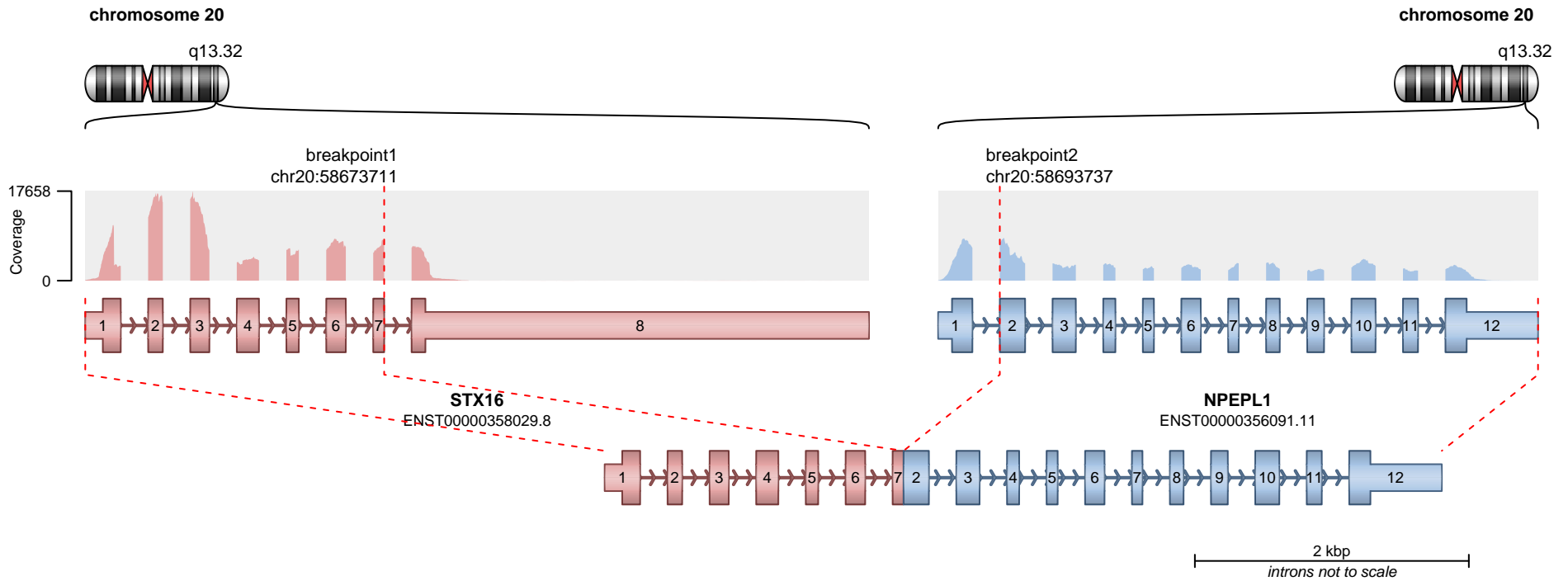

RETAINED PROTEIN DOMAINS
reading frame unclear

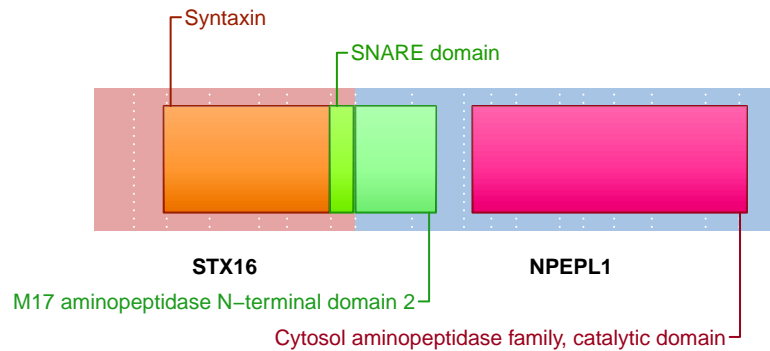

SUPPORTING READ COUNT

Split reads = 9
Discordant mates = 0

— translocation — deletion
— duplication — inversion

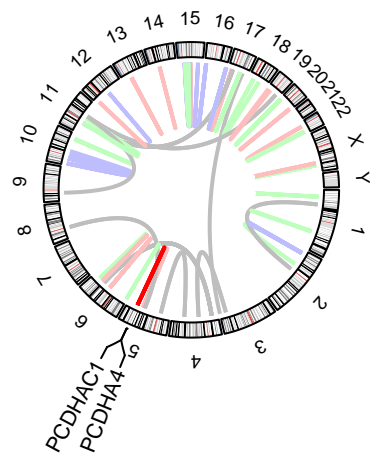
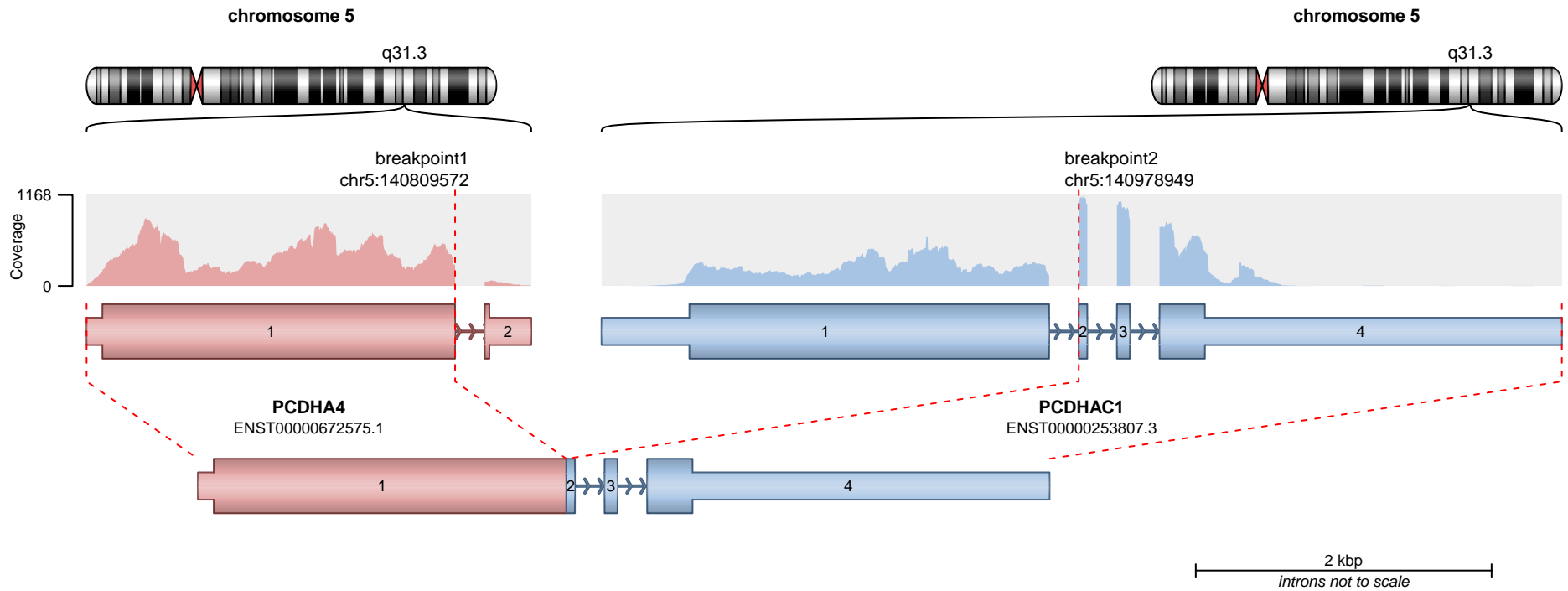

RETAINED PROTEIN DOMAINS
reading frame unclear

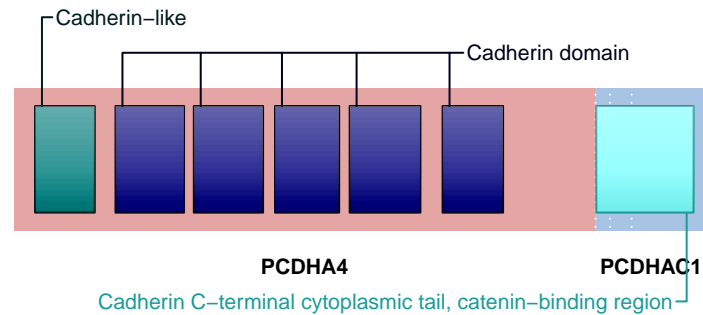

SUPPORTING READ COUNT

Split reads = 66
Discordant mates = 0

— translocation — deletion
— duplication — inversion

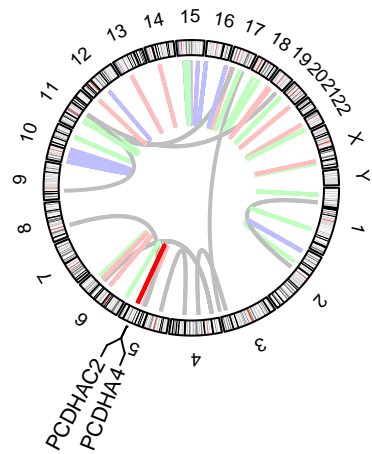
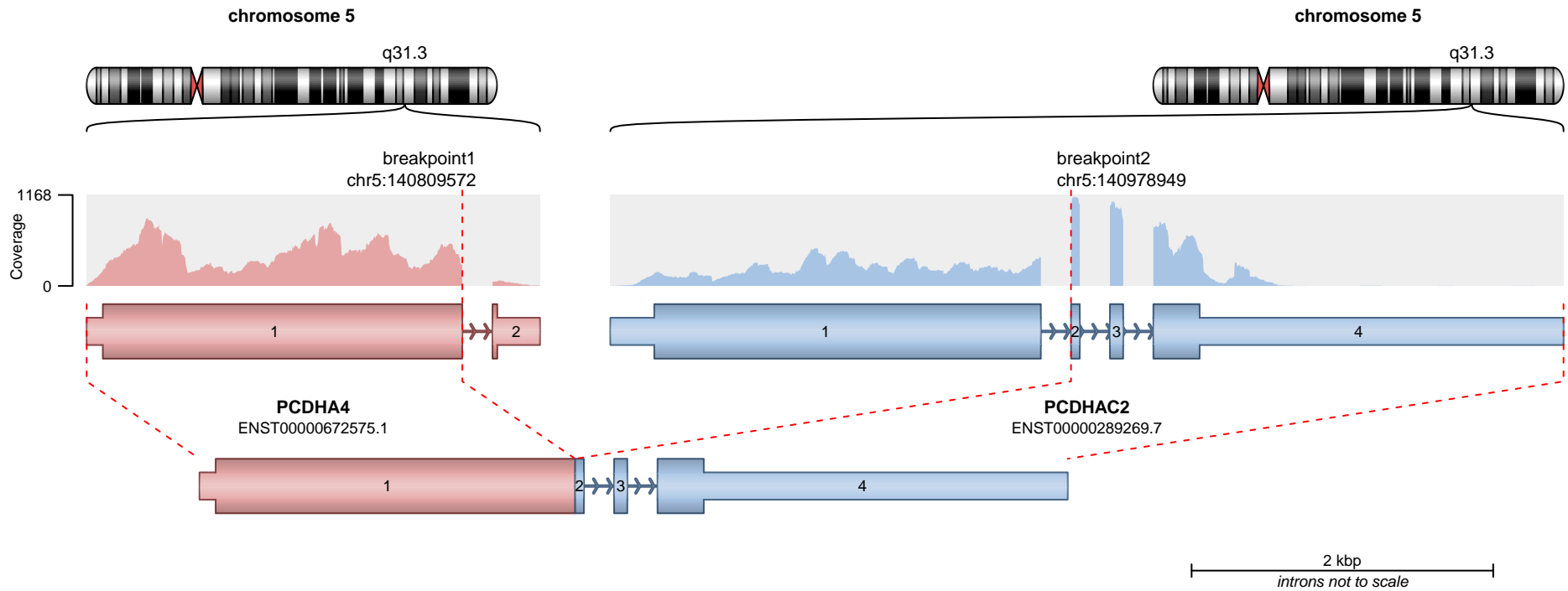

RETAINED PROTEIN DOMAINS
reading frame unclear

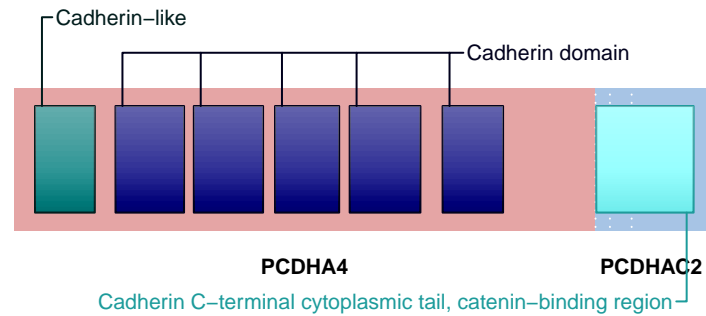

SUPPORTING READ COUNT

Split reads = 66
Discordant mates = 0

— translocation — deletion
— duplication — inversion

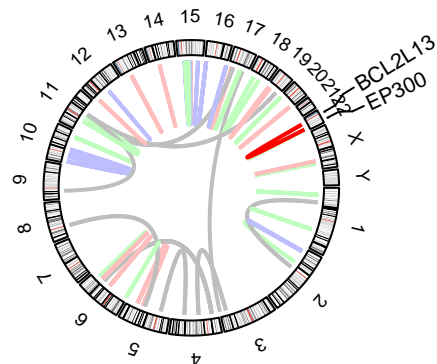
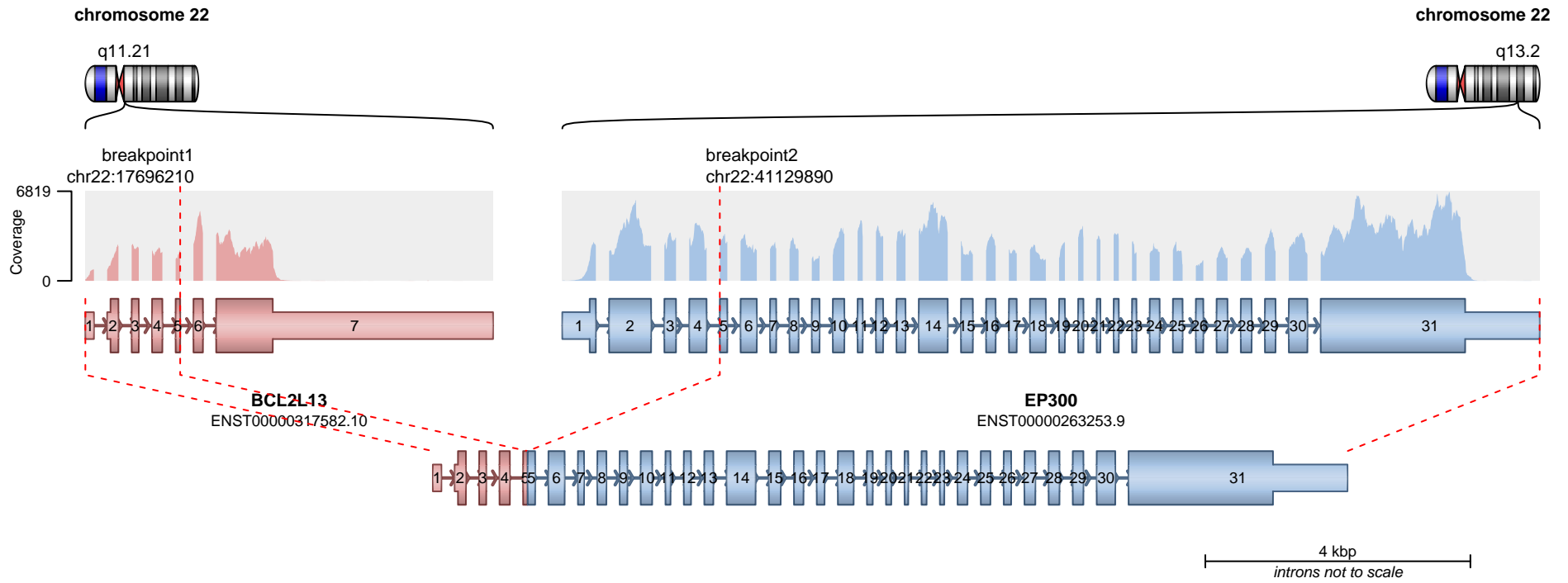

— translocation — deletion
— duplication — inversion

RETAINED PROTEIN DOMAINS
reading frame unclear

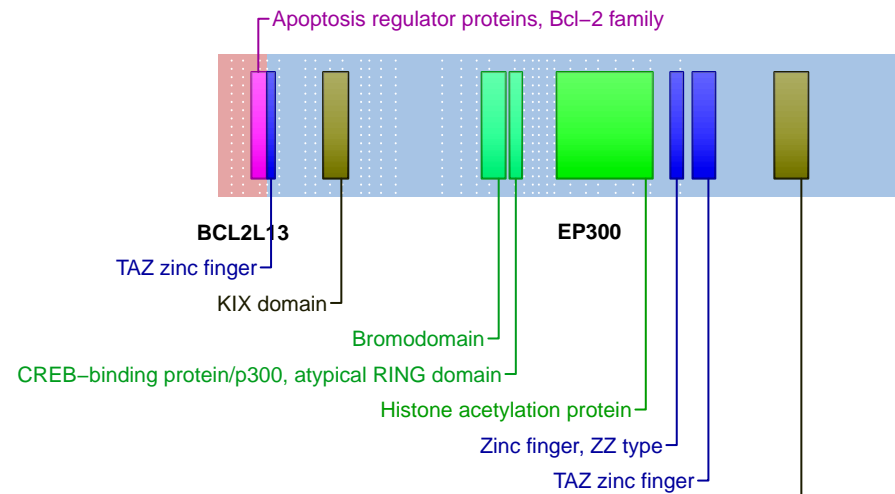

SUPPORTING READ COUNT

Split reads = 62
Discordant mates = 3

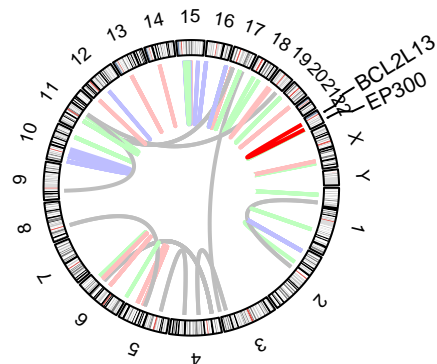
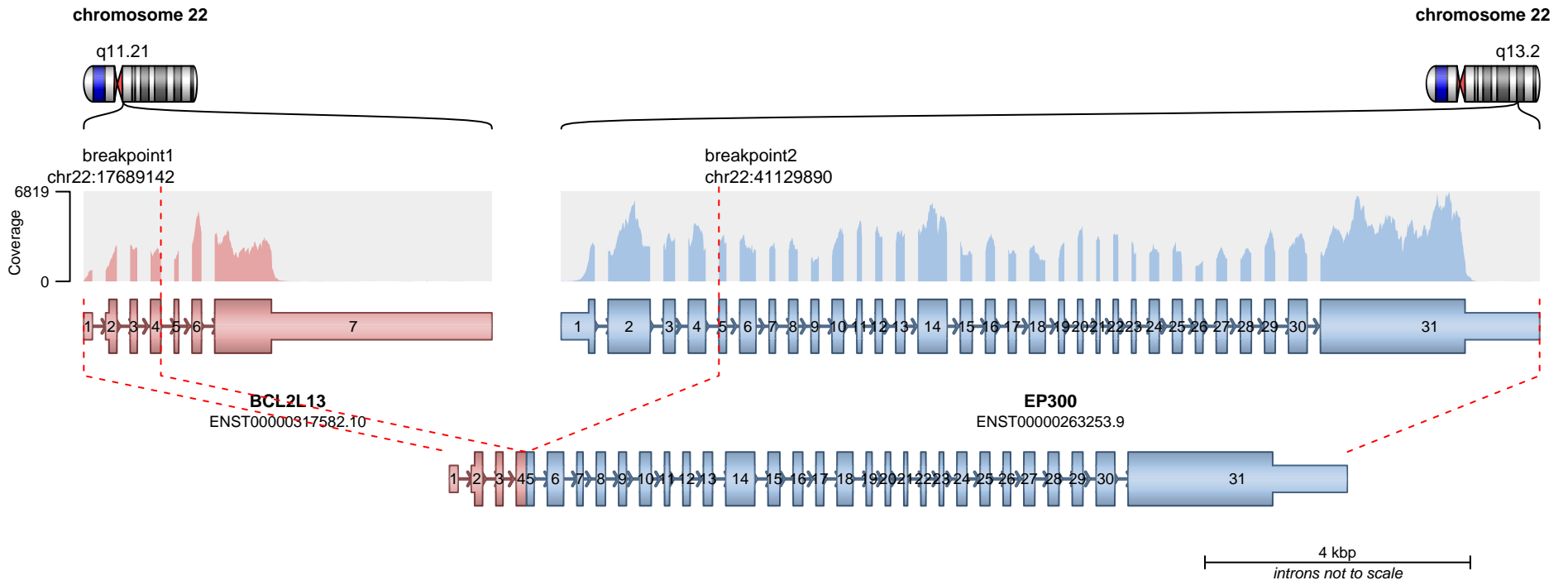

— translocation — deletion
— duplication — inversion

RETAINED PROTEIN DOMAINS
reading frame unclear

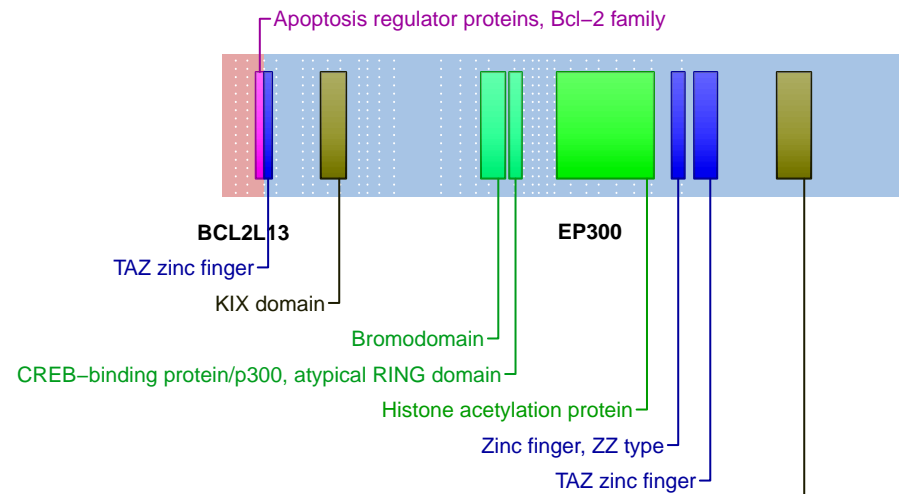

SUPPORTING READ COUNT

Split reads = 21
Discordant mates = 2

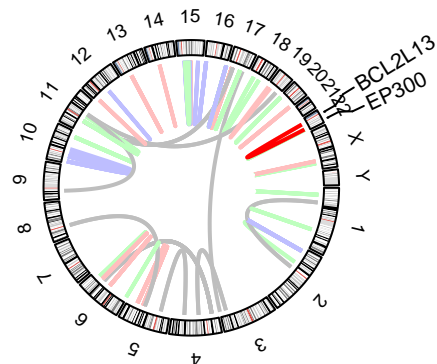
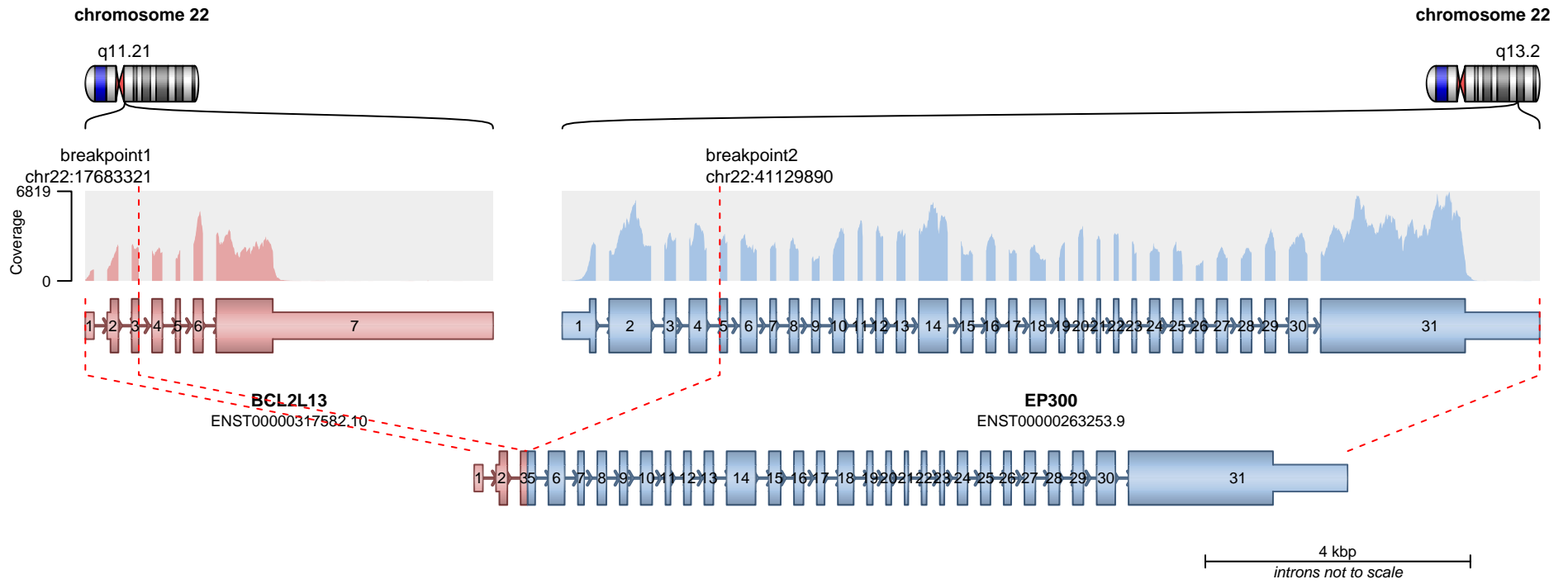

— translocation — deletion
— duplication — inversion

RETAINED PROTEIN DOMAINS
reading frame unclear

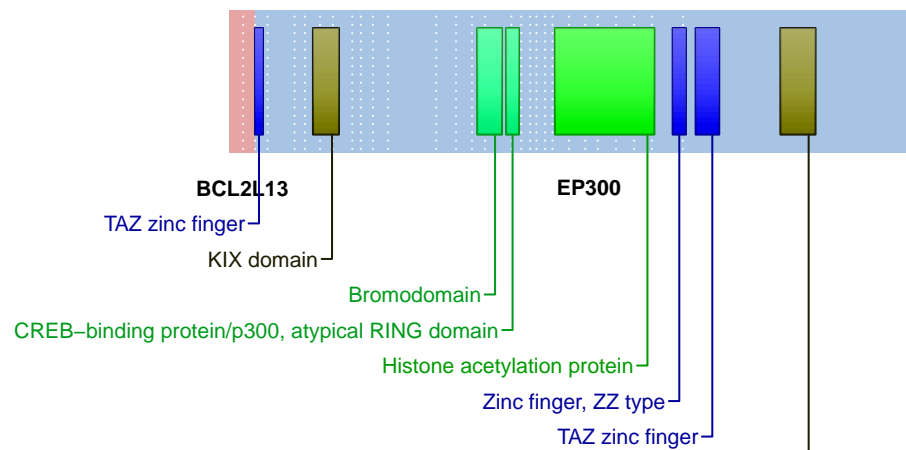

SUPPORTING READ COUNT

Split reads = 2
Discordant mates = 0

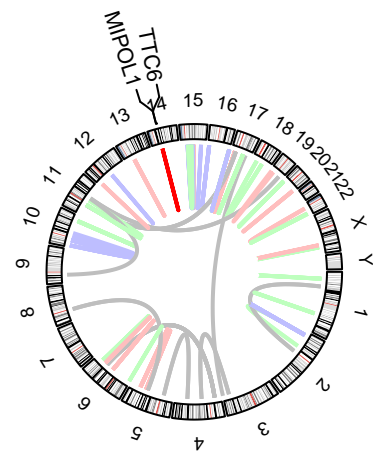
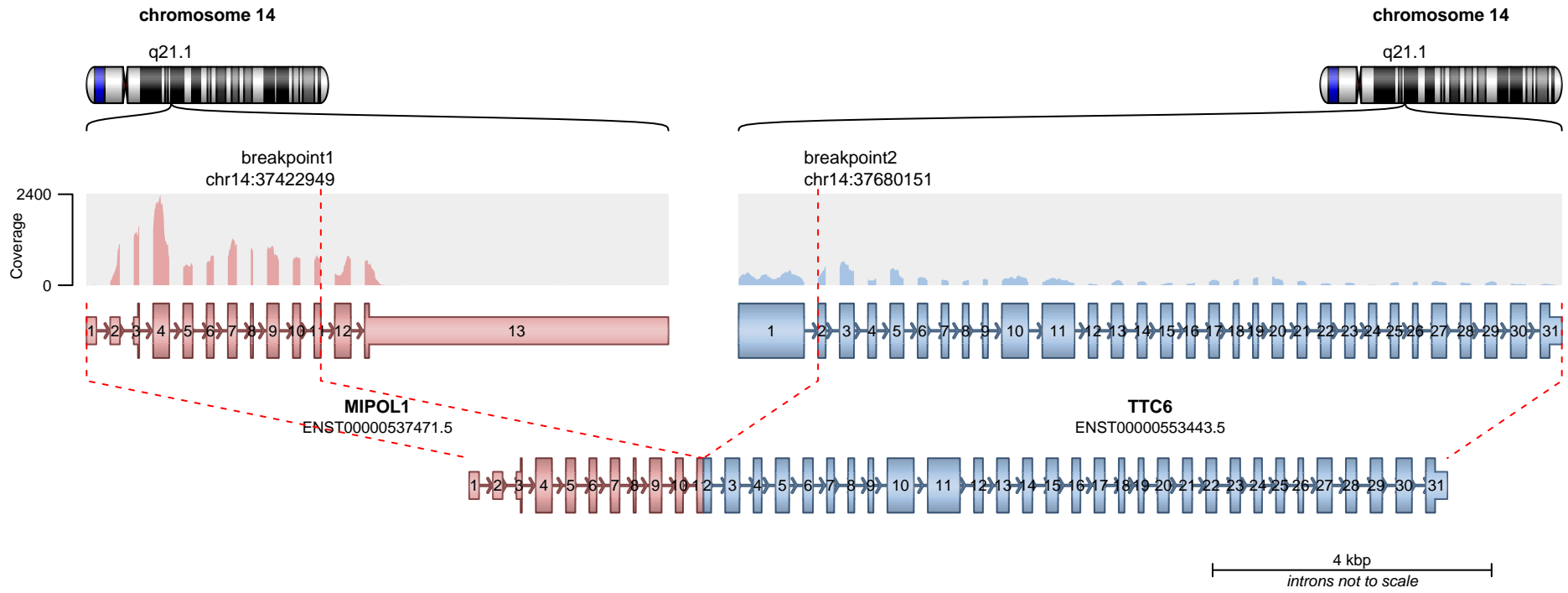

— translocation — deletion
— duplication — inversion

RETAINED PROTEIN DOMAINS
reading frame unclear

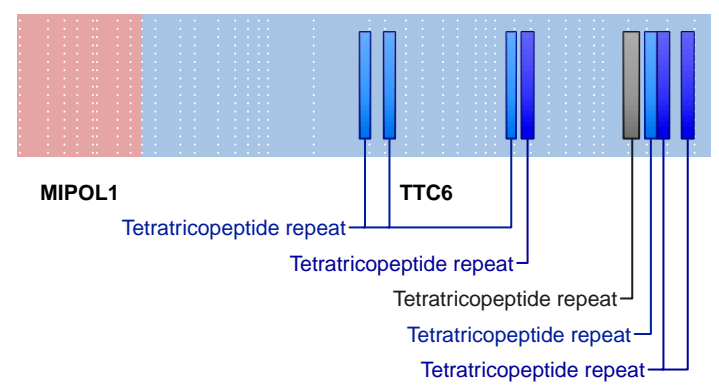

SUPPORTING READ COUNT

Split reads = 56
Discordant mates = 3

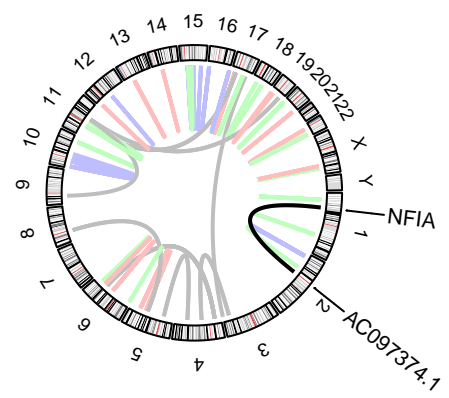
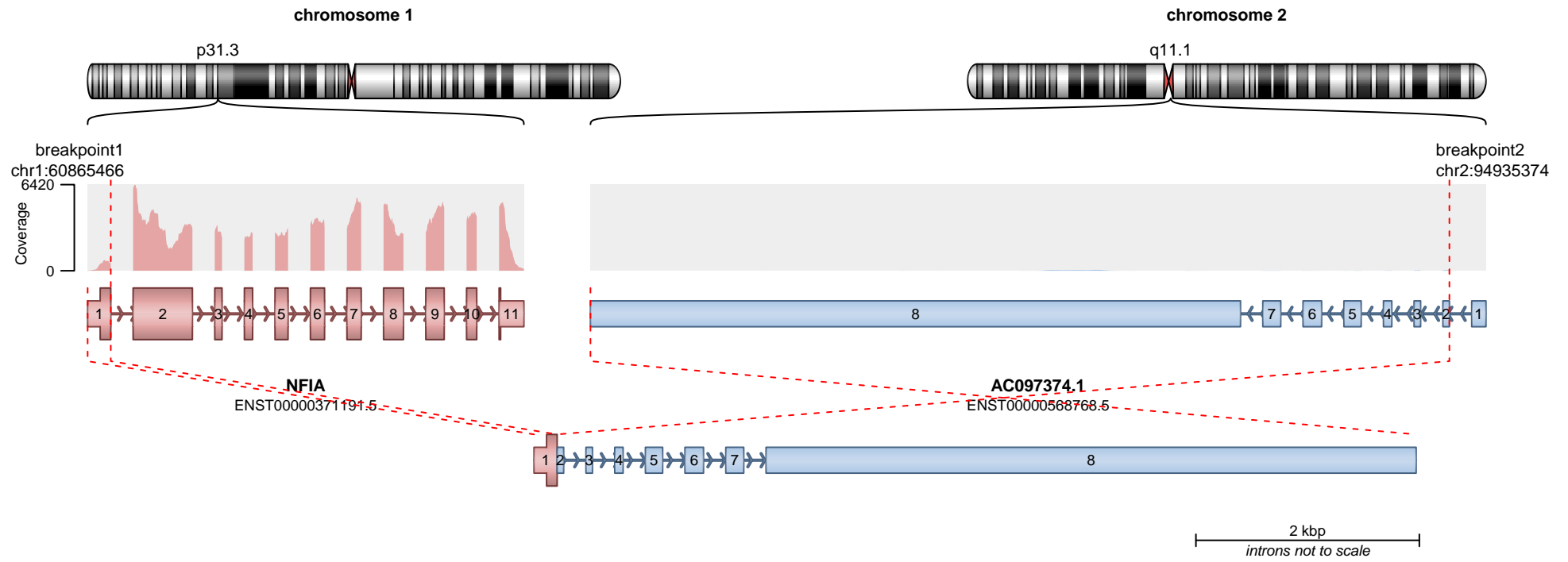

No protein domains retained in fusion.

SUPPORTING READ COUNT

Split reads = 52
Discordant mates = 0

- translocation
- duplication
- deletion
- inversion

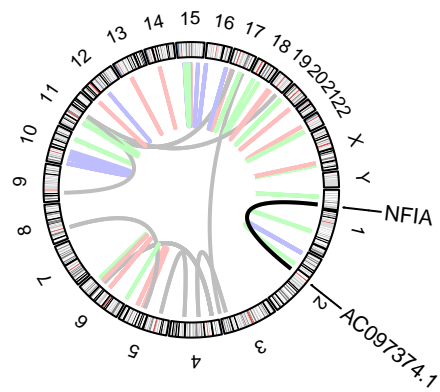
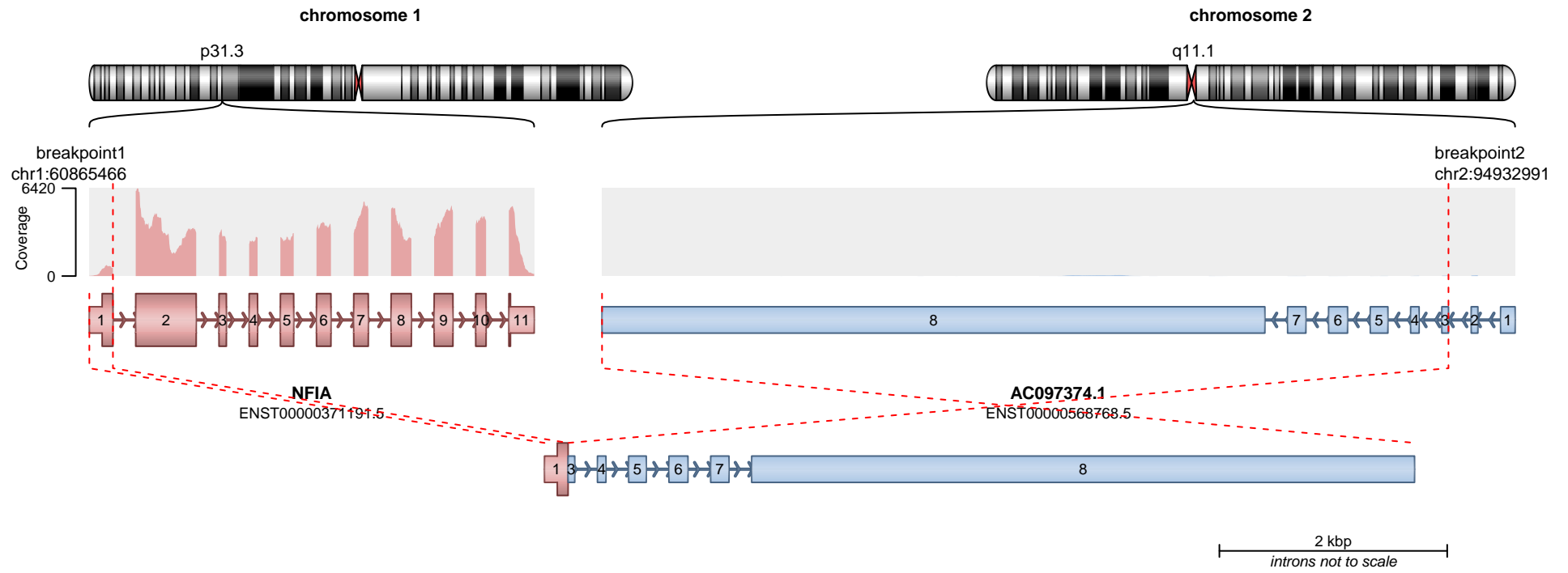

— translocation — deletion
— duplication — inversion

No protein domains retained in fusion.

SUPPORTING READ COUNT

Split reads = 6
Discordant mates = 0

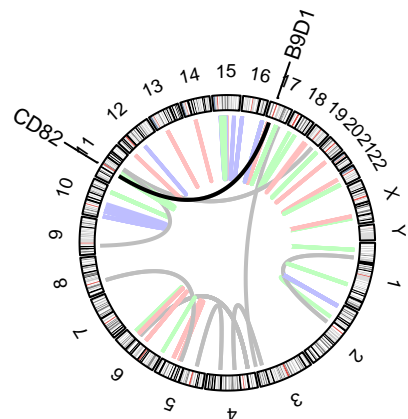
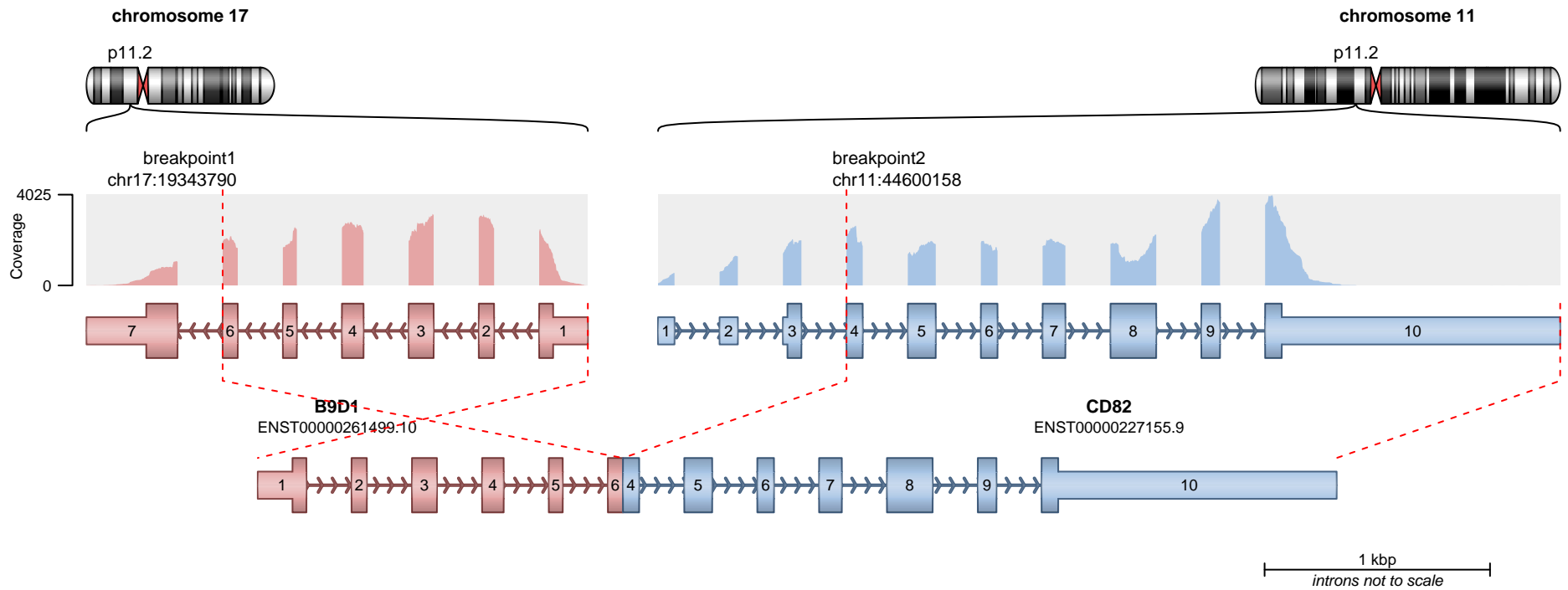

RETAINED PROTEIN DOMAINS
reading frame unclear

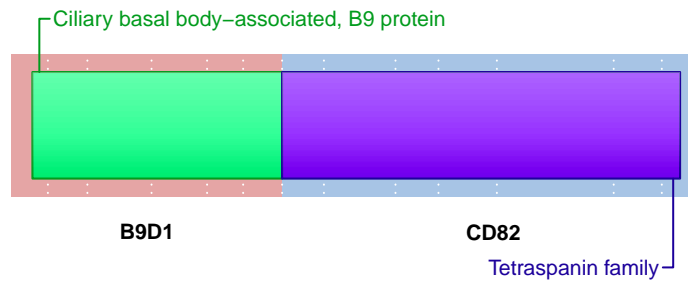

SUPPORTING READ COUNT

Split reads = 51
Discordant mates = 2

— translocation — deletion
— duplication — inversion

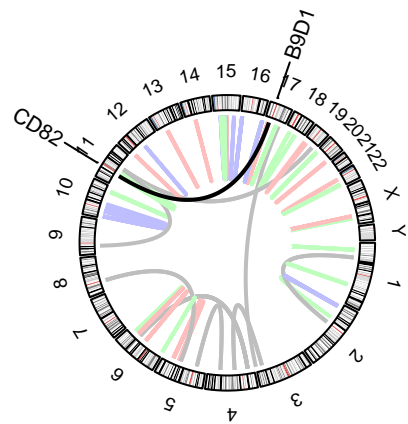
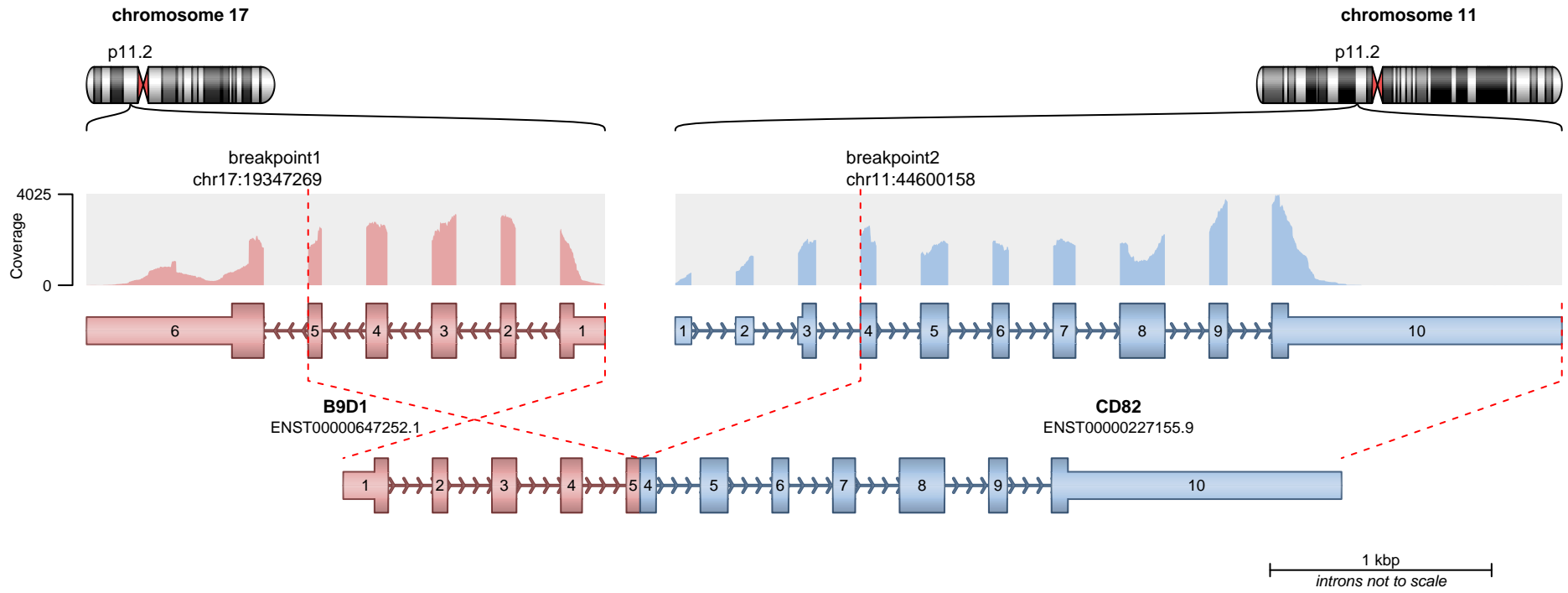

RETAINED PROTEIN DOMAINS
reading frame unclear

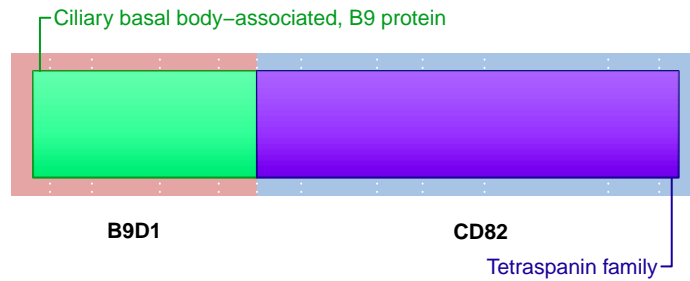

SUPPORTING READ COUNT

Split reads = 23
Discordant mates = 0

- translocation
- duplication
- deletion
- inversion

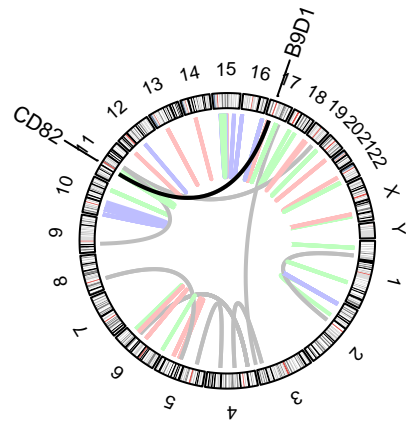
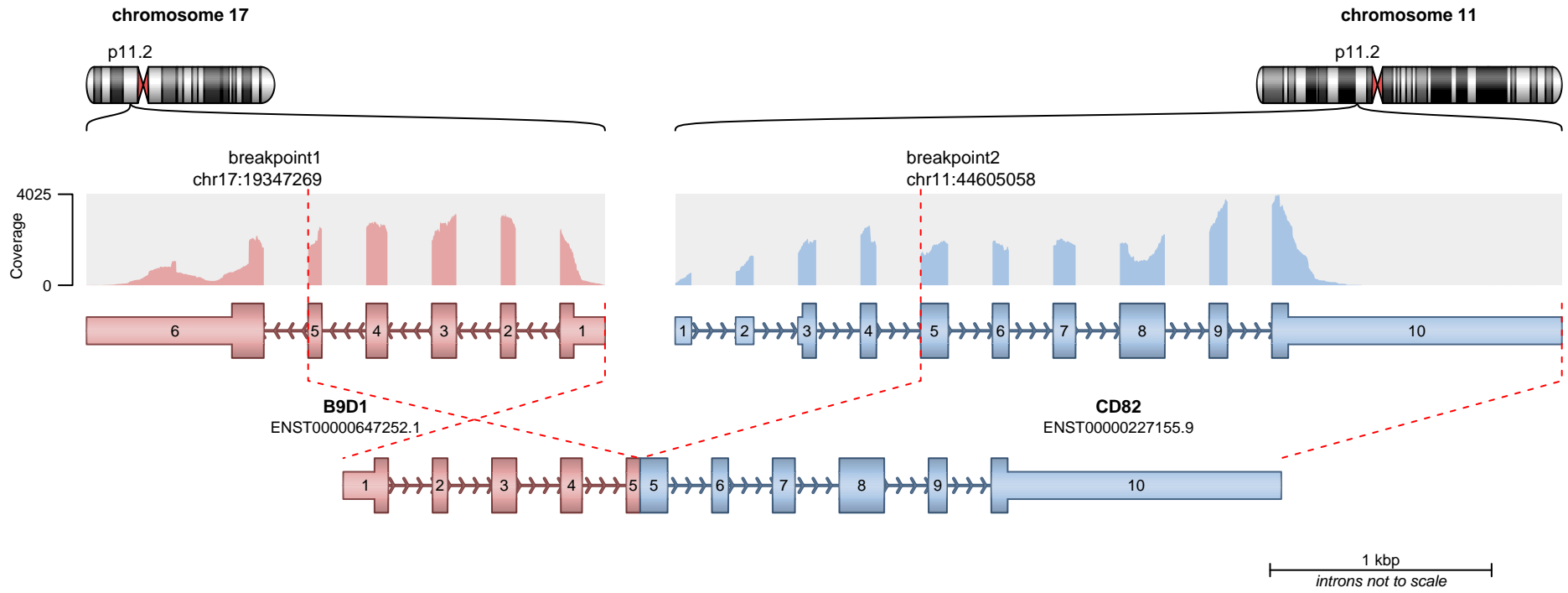

RETAINED PROTEIN DOMAINS
reading frame unclear

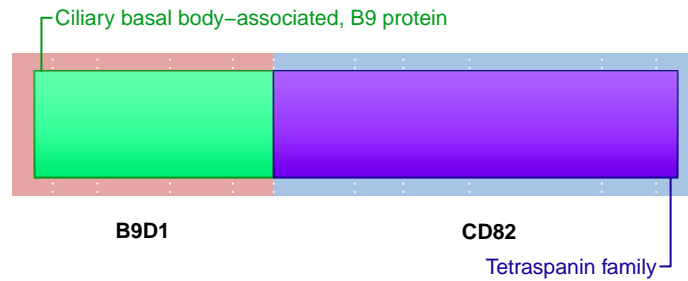

SUPPORTING READ COUNT

Split reads = 1
Discordant mates = 0

— translocation — deletion
— duplication — inversion

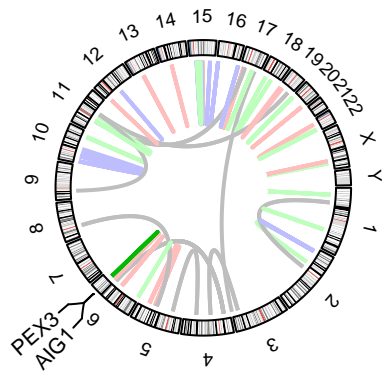
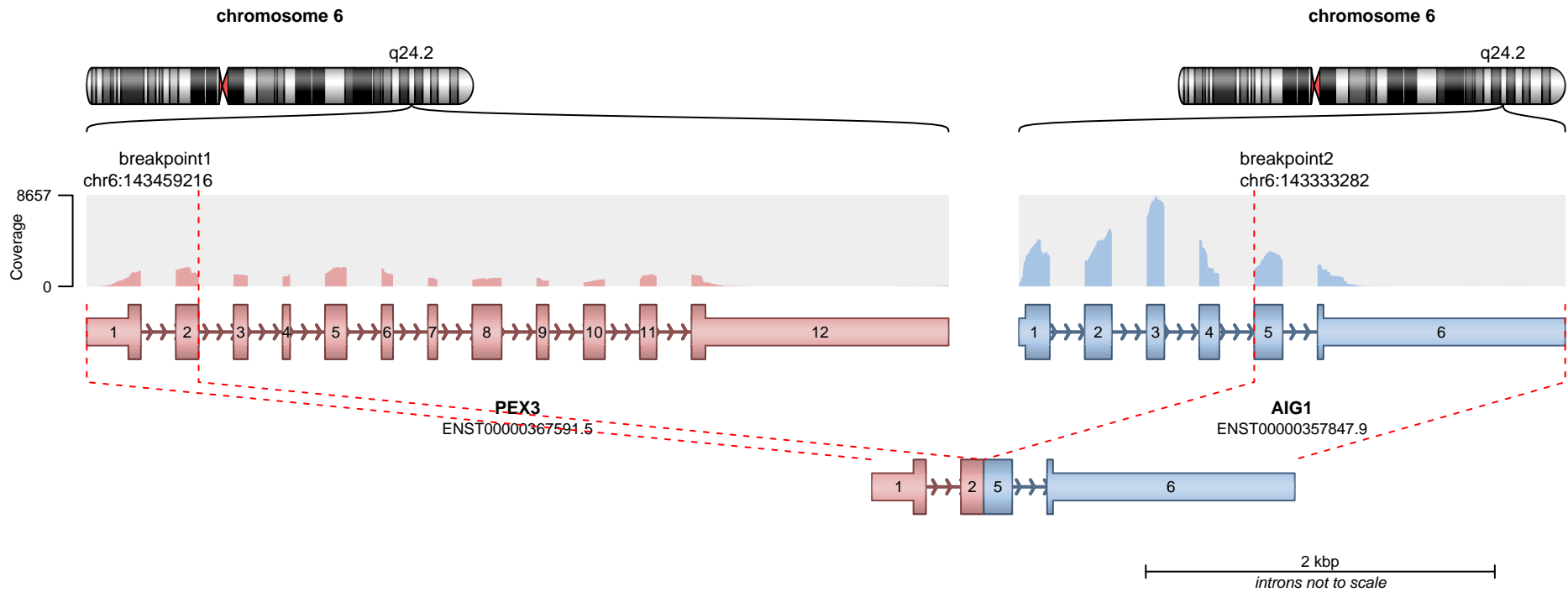

RETAINED PROTEIN DOMAINS
reading frame unclear

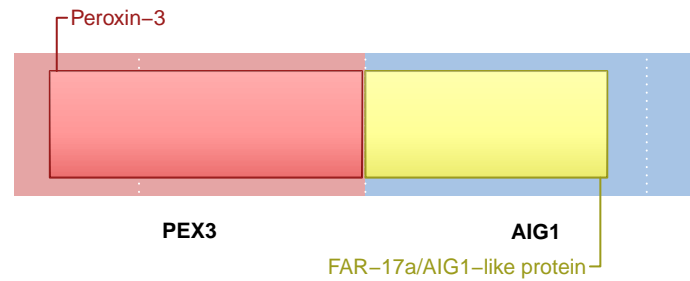

SUPPORTING READ COUNT

Split reads = 46
Discordant mates = 1

— translocation — deletion
— duplication — inversion

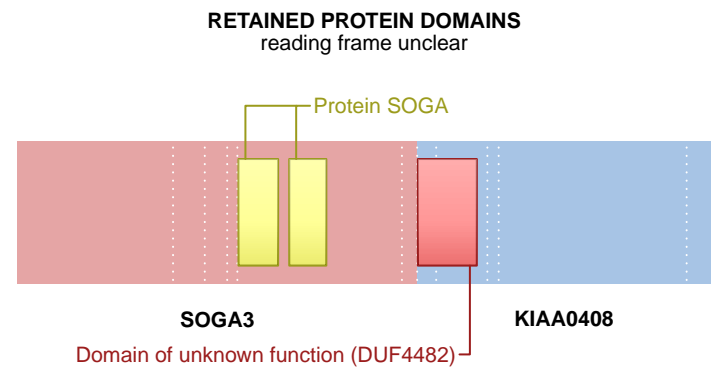
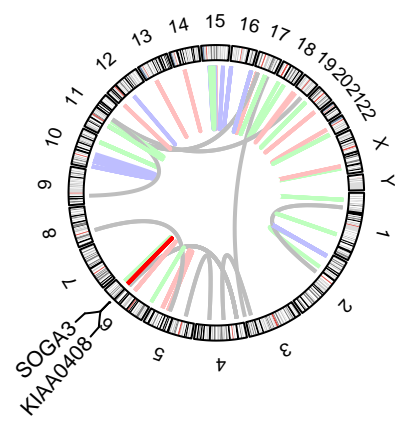
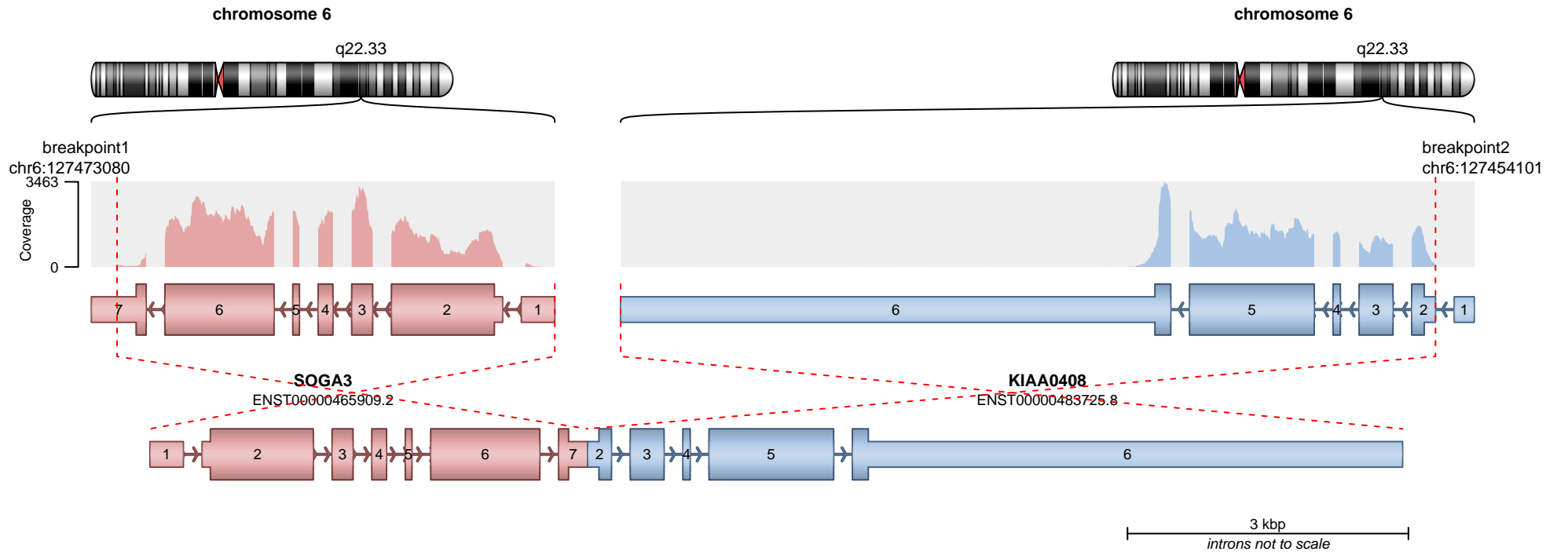

SUPPORTING READ COUNT

Split reads = 42
Discordant mates = 5

— translocation — deletion
— duplication — inversion

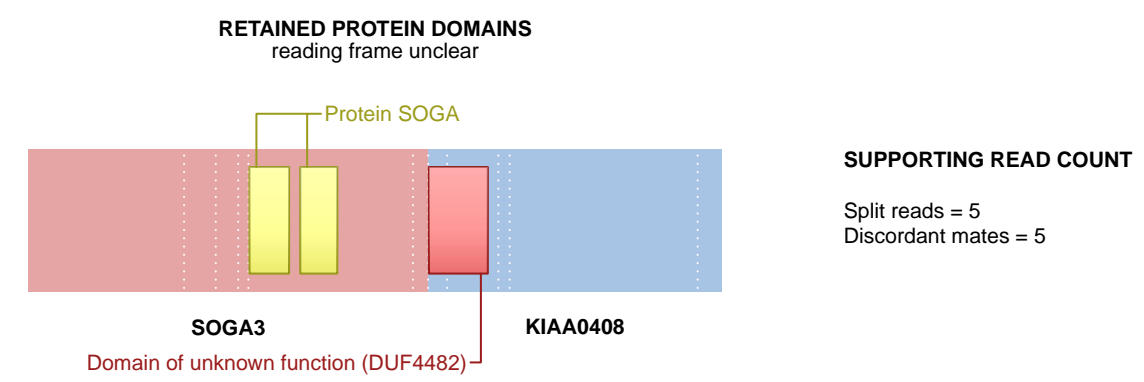
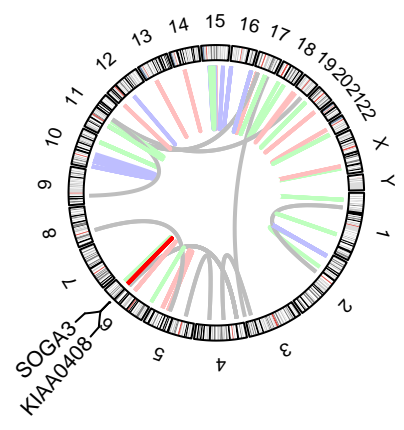
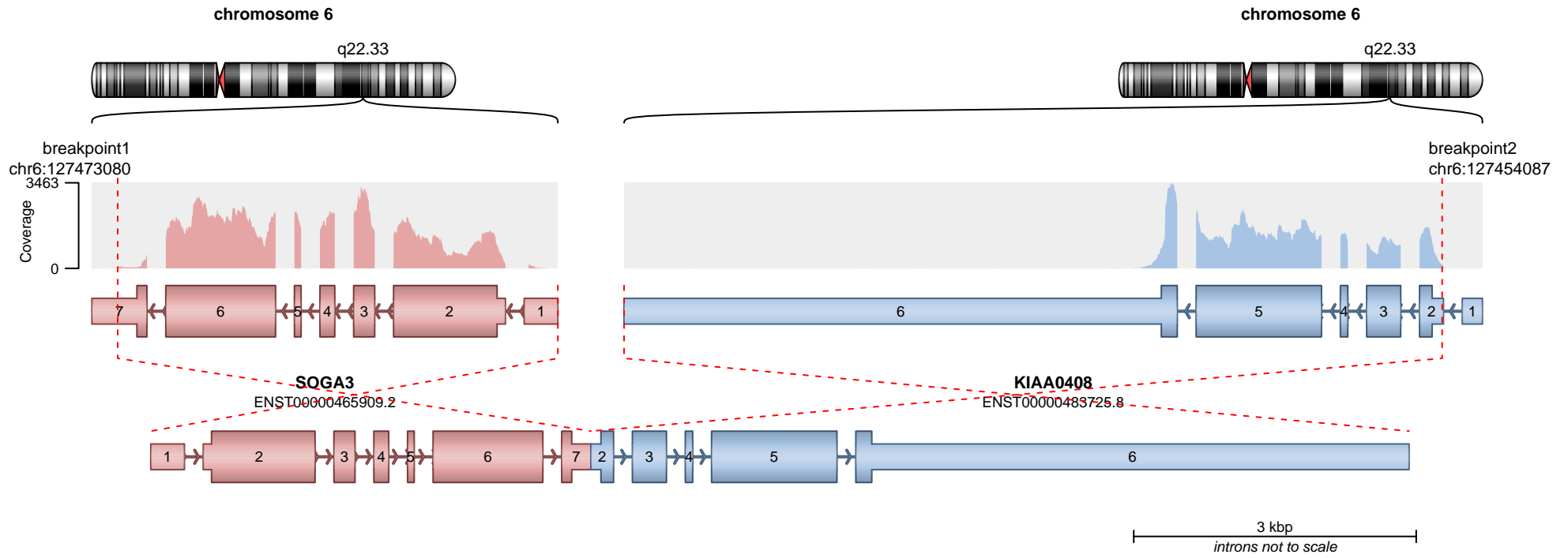

— translocation — deletion
— duplication — inversion

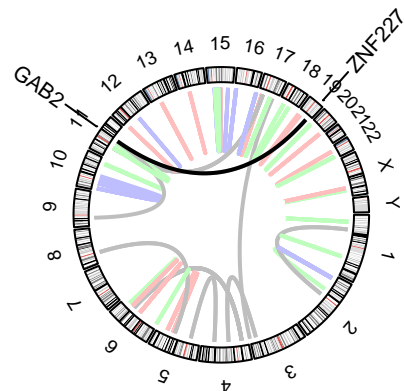
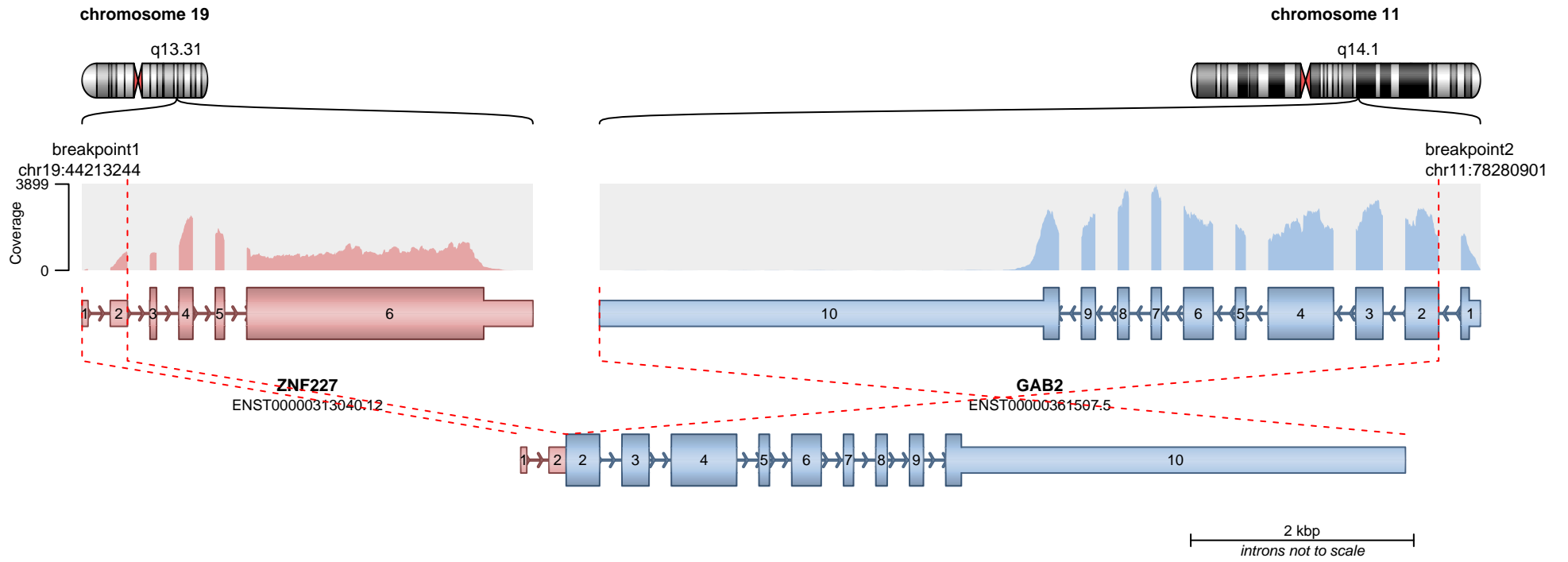

RETAINED PROTEIN DOMAINS
reading frame unclear

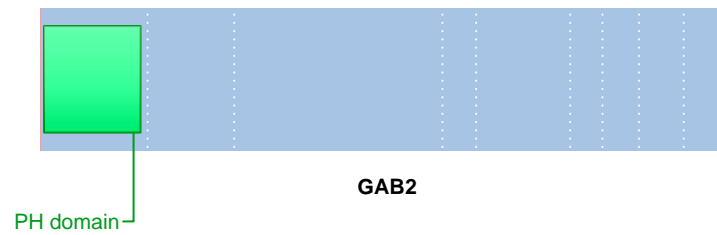

SUPPORTING READ COUNT

Split reads = 42
Discordant mates = 4

— translocation — deletion
— duplication — inversion

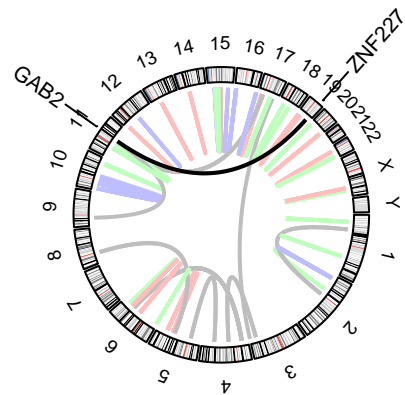
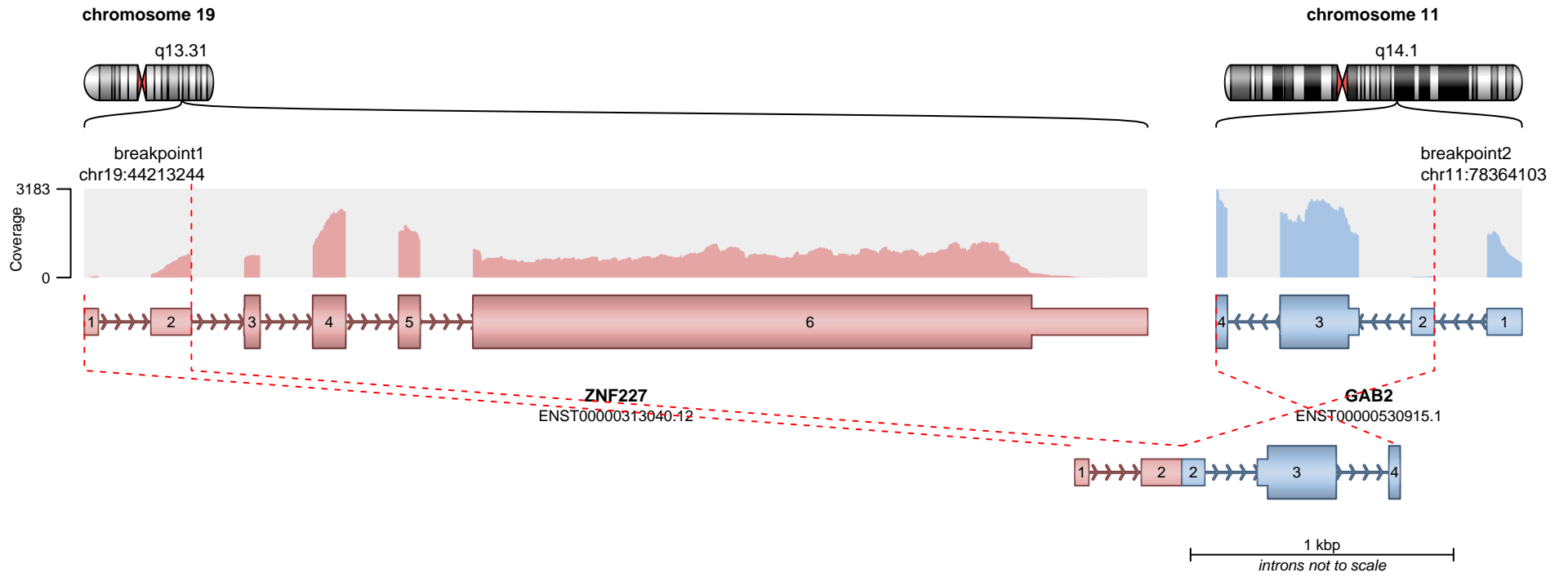

RETAINED PROTEIN DOMAINS
reading frame unclear

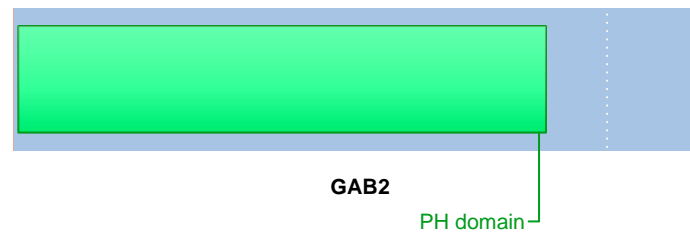

SUPPORTING READ COUNT

Split reads = 1
Discordant mates = 4

— translocation — deletion
— duplication — inversion

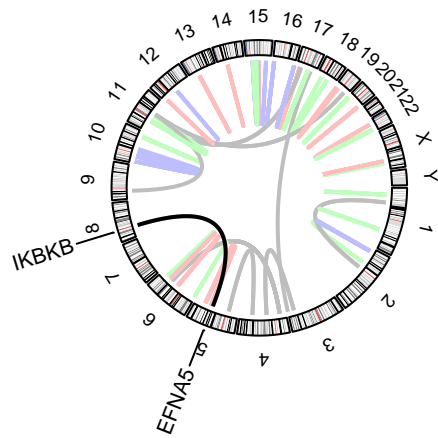
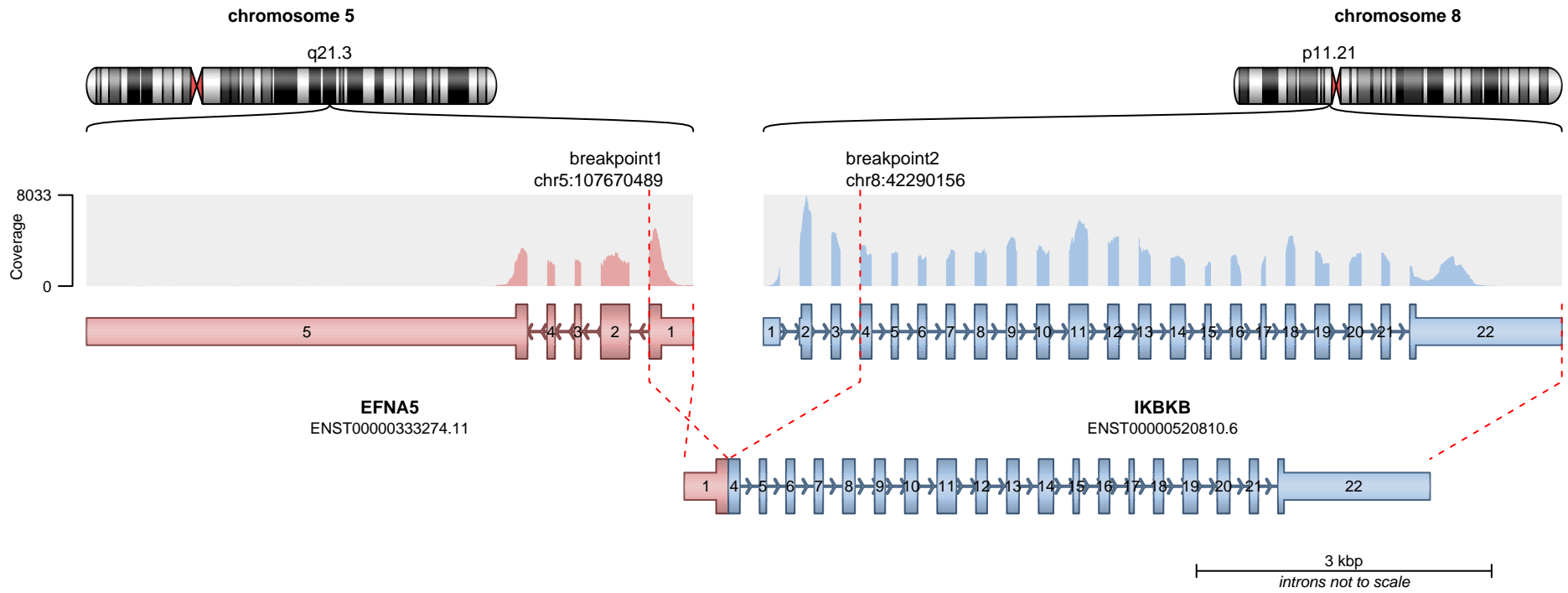

RETAINED PROTEIN DOMAINS
reading frame unclear

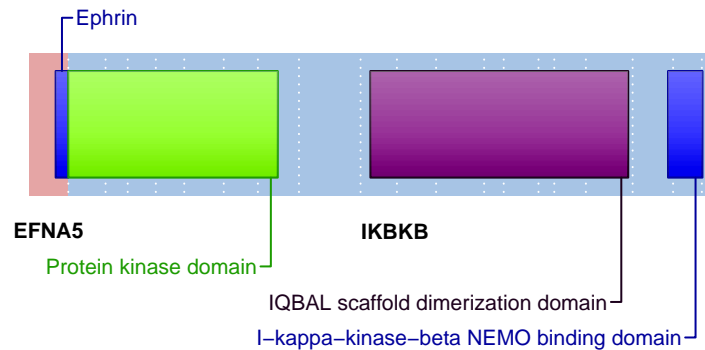

SUPPORTING READ COUNT

Split reads = 42
Discordant mates = 1

— translocation — deletion
— duplication — inversion

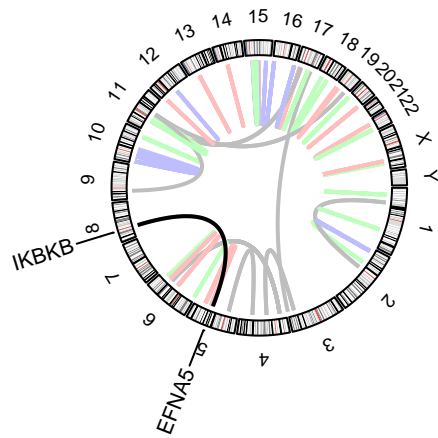
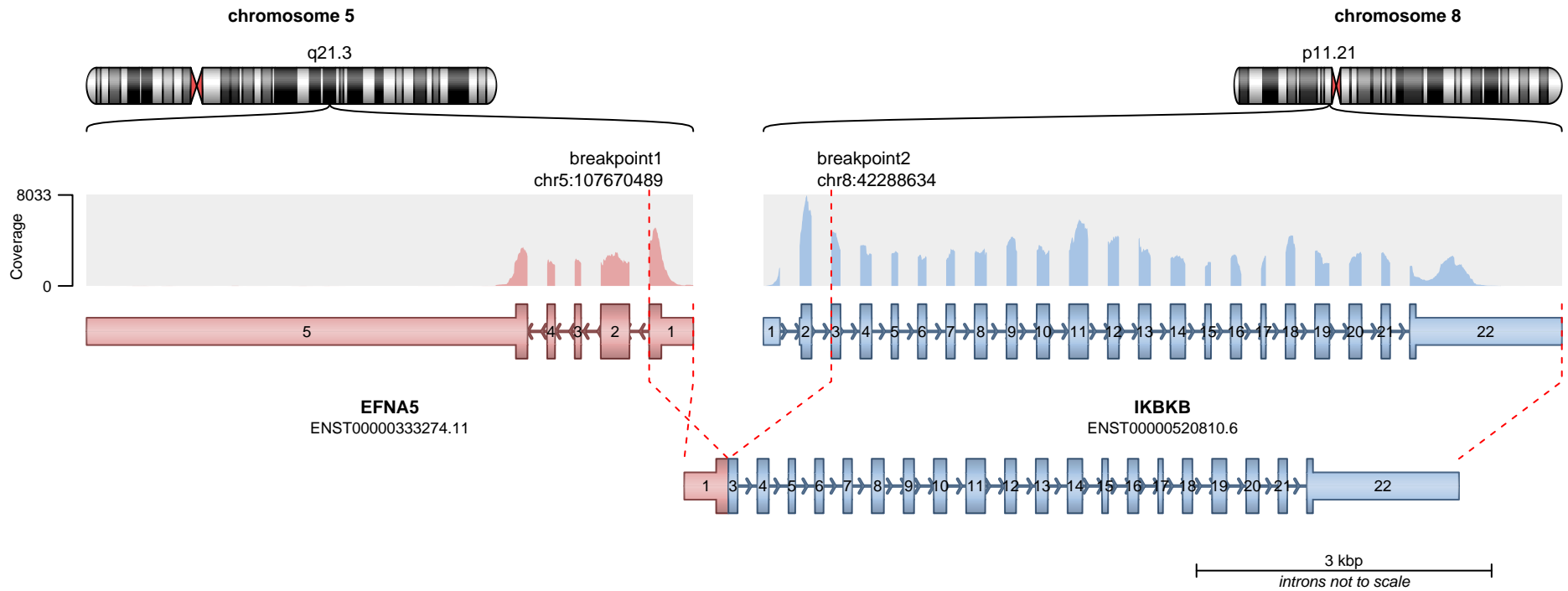

RETAINED PROTEIN DOMAINS
reading frame unclear

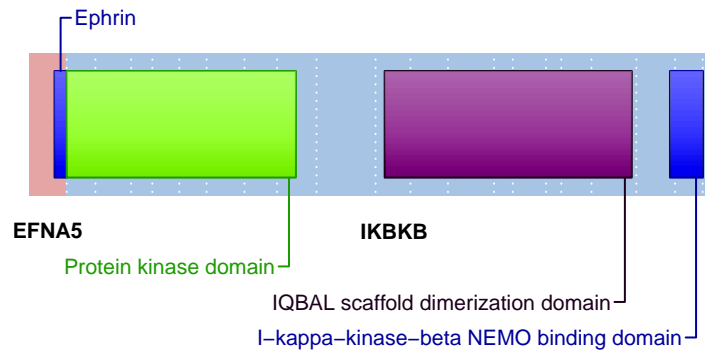

SUPPORTING READ COUNT

Split reads = 1
Discordant mates = 1

— translocation — deletion
— duplication — inversion

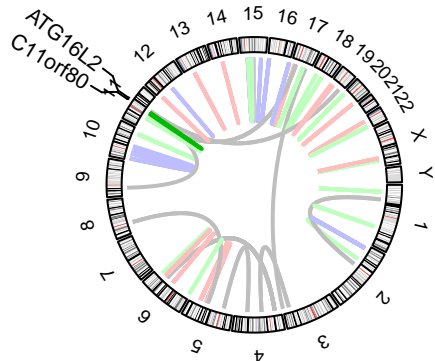
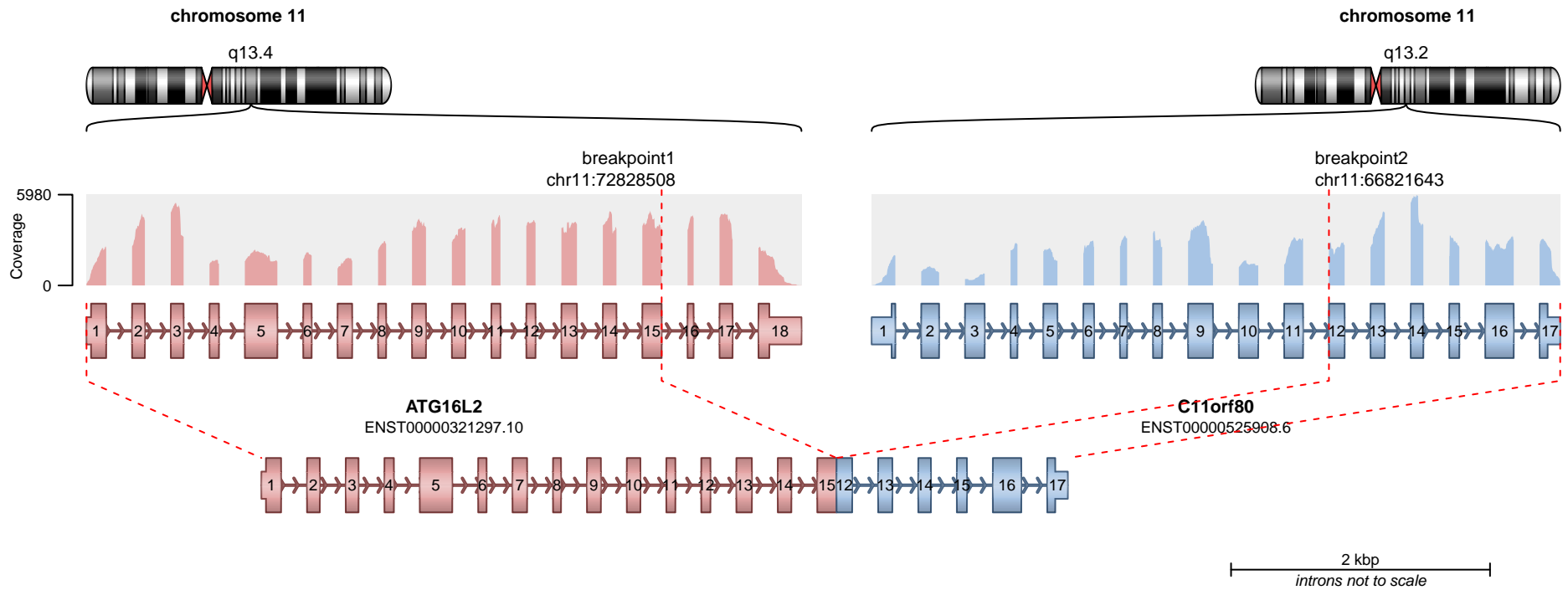

RETAINED PROTEIN DOMAINS
reading frame unclear

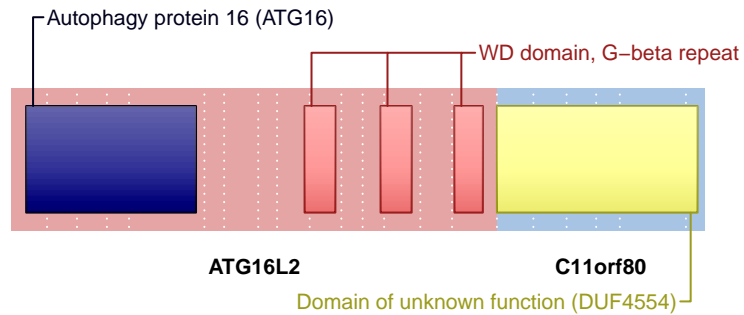

SUPPORTING READ COUNT

Split reads = 41
Discordant mates = 0

- translocation
- duplication
- deletion
- inversion

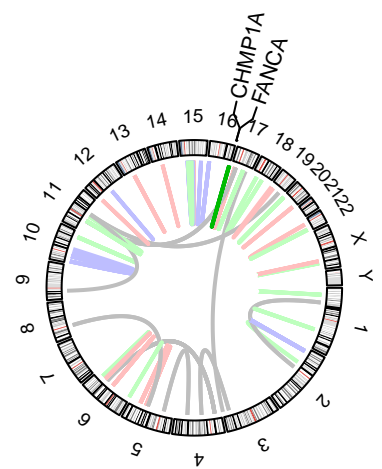
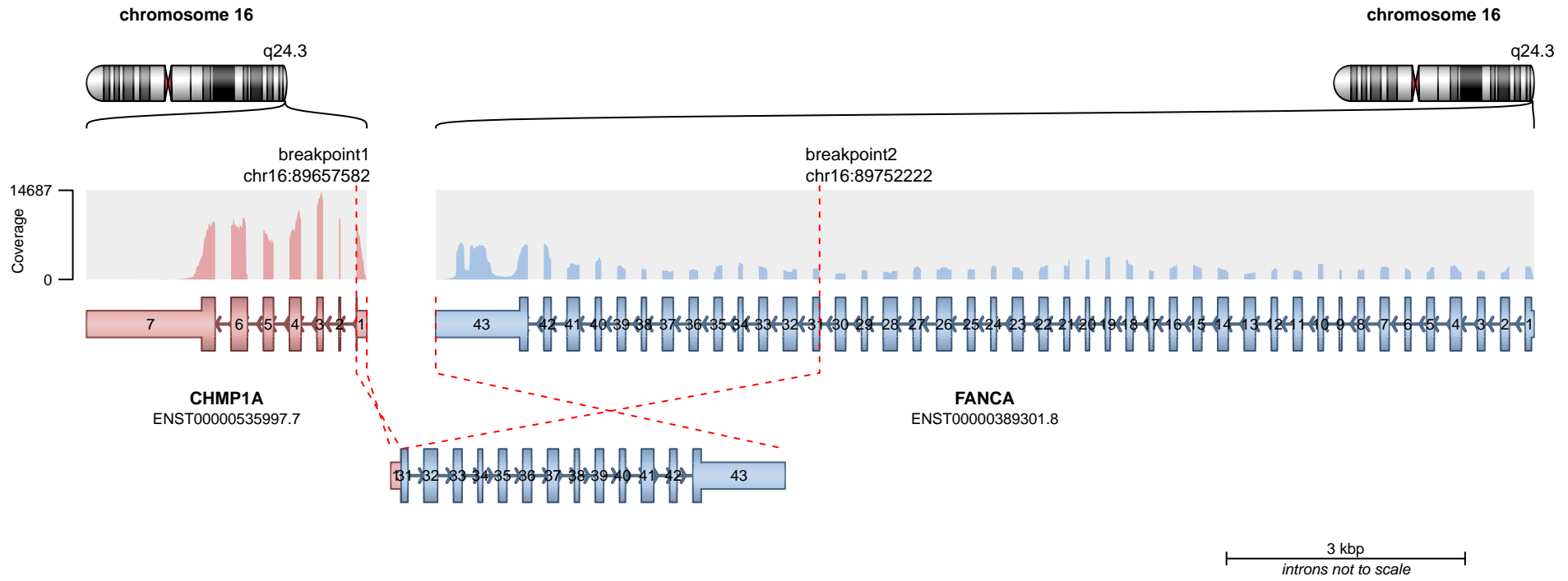

RETAINED PROTEIN DOMAINS
reading frame unclear

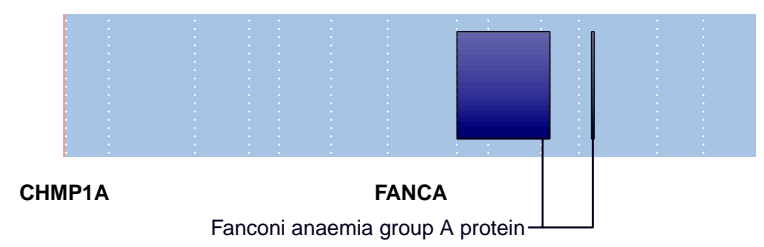

SUPPORTING READ COUNT

Split reads = 39
Discordant mates = 0

- translocation
- duplication
- deletion
- inversion

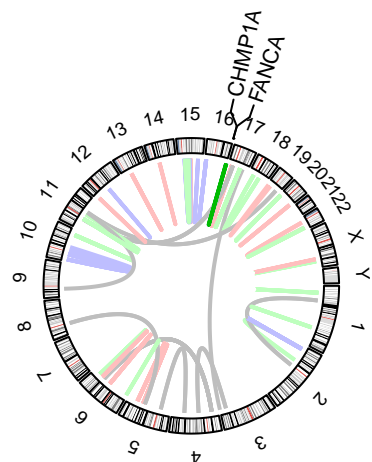
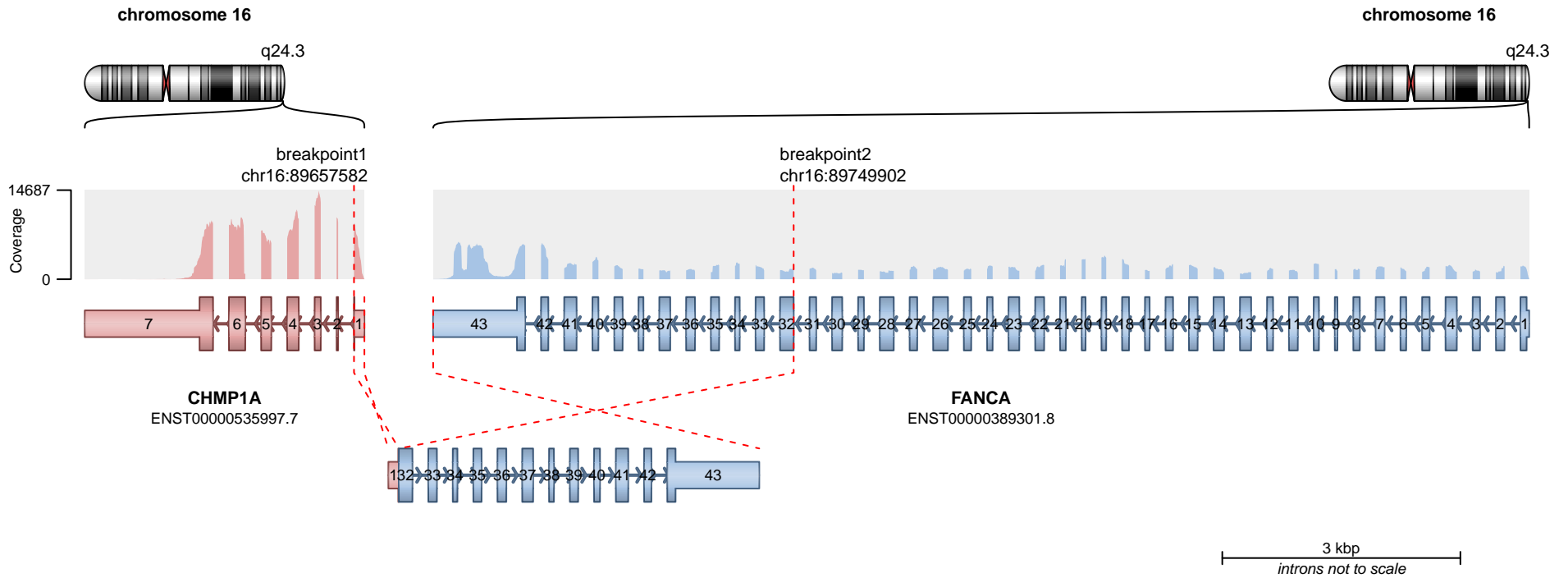

— translocation — deletion
— duplication — inversion

RETAINED PROTEIN DOMAINS
reading frame unclear

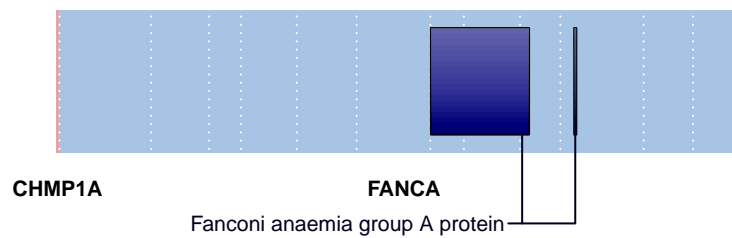

SUPPORTING READ COUNT

Split reads = 9
Discordant mates = 0

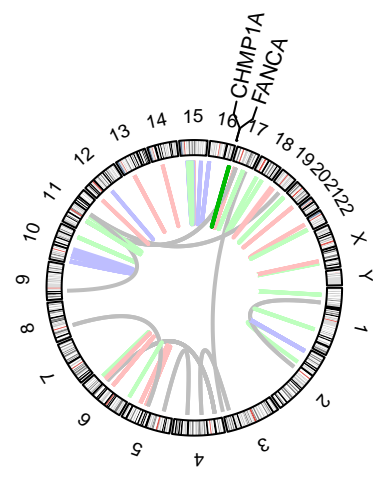
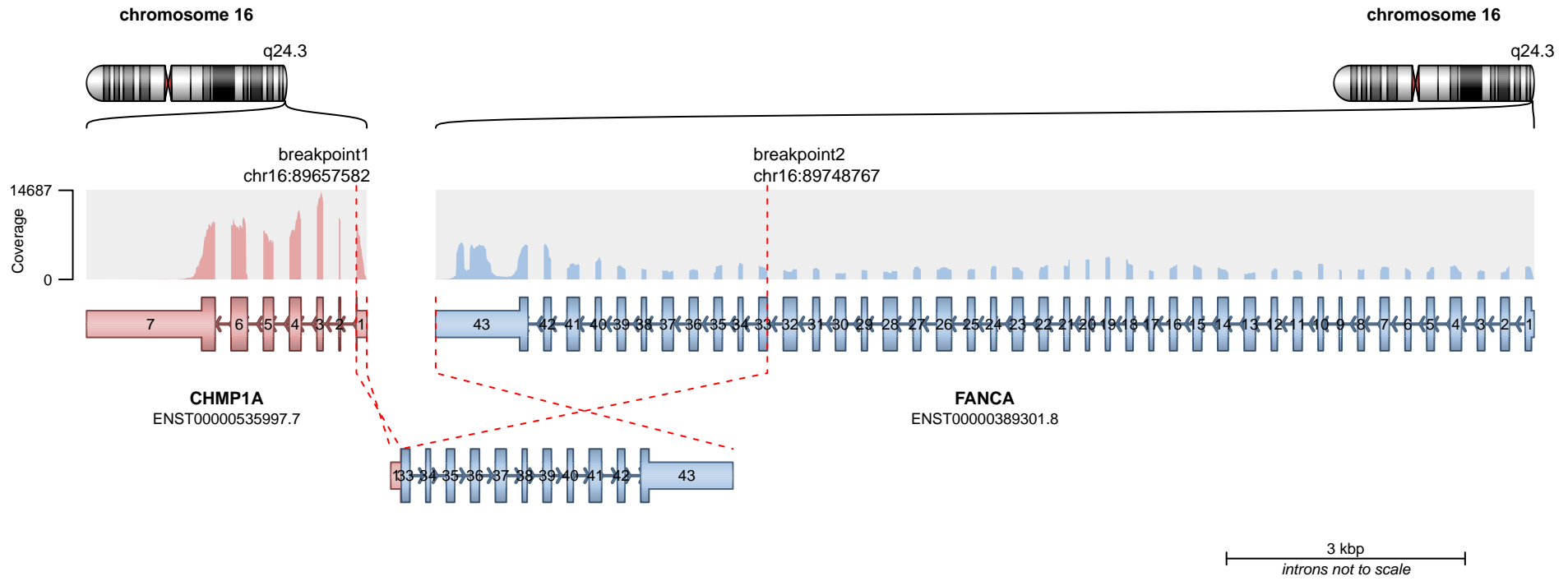

RETAINED PROTEIN DOMAINS
reading frame unclear

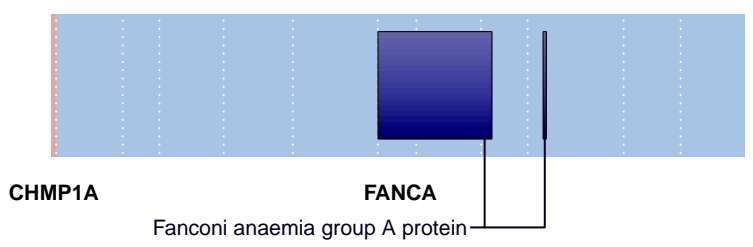

SUPPORTING READ COUNT

Split reads = 2
Discordant mates = 0

- translocation
- duplication
- deletion
- inversion

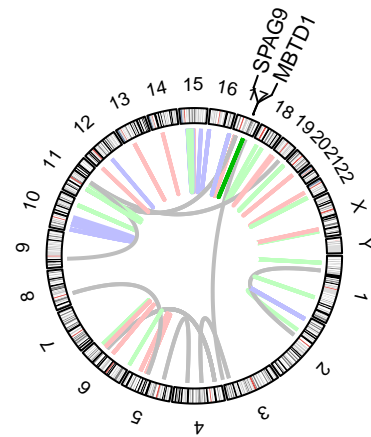
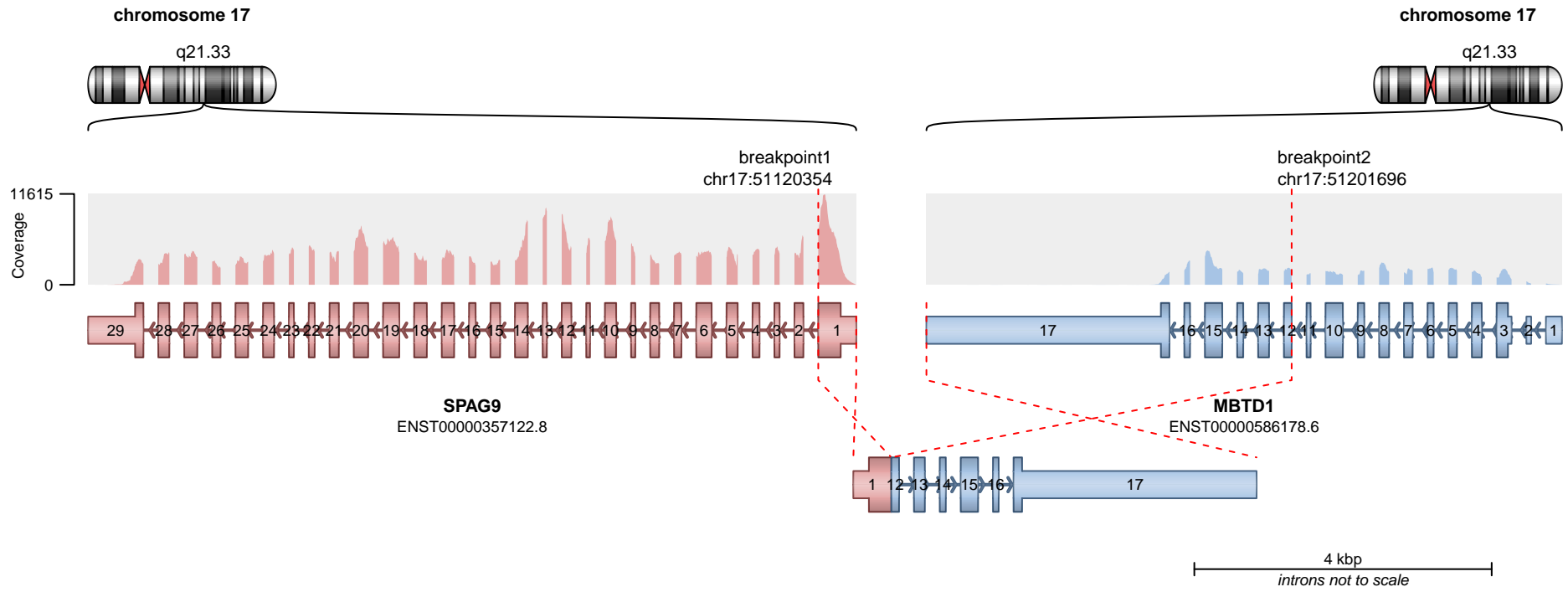

RETAINED PROTEIN DOMAINS
reading frame unclear

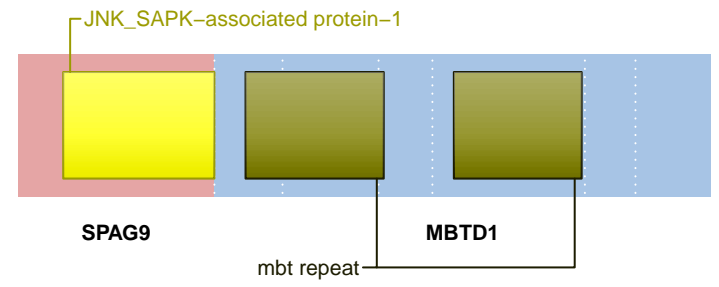

SUPPORTING READ COUNT

Split reads = 38
Discordant mates = 0

- translocation
- duplication
- deletion
- inversion

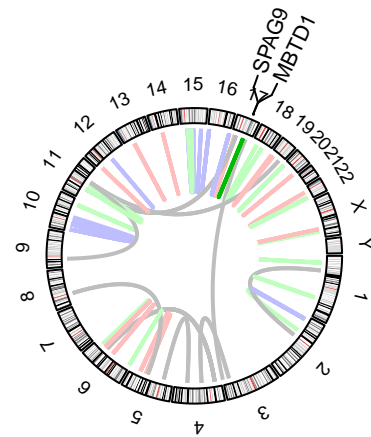
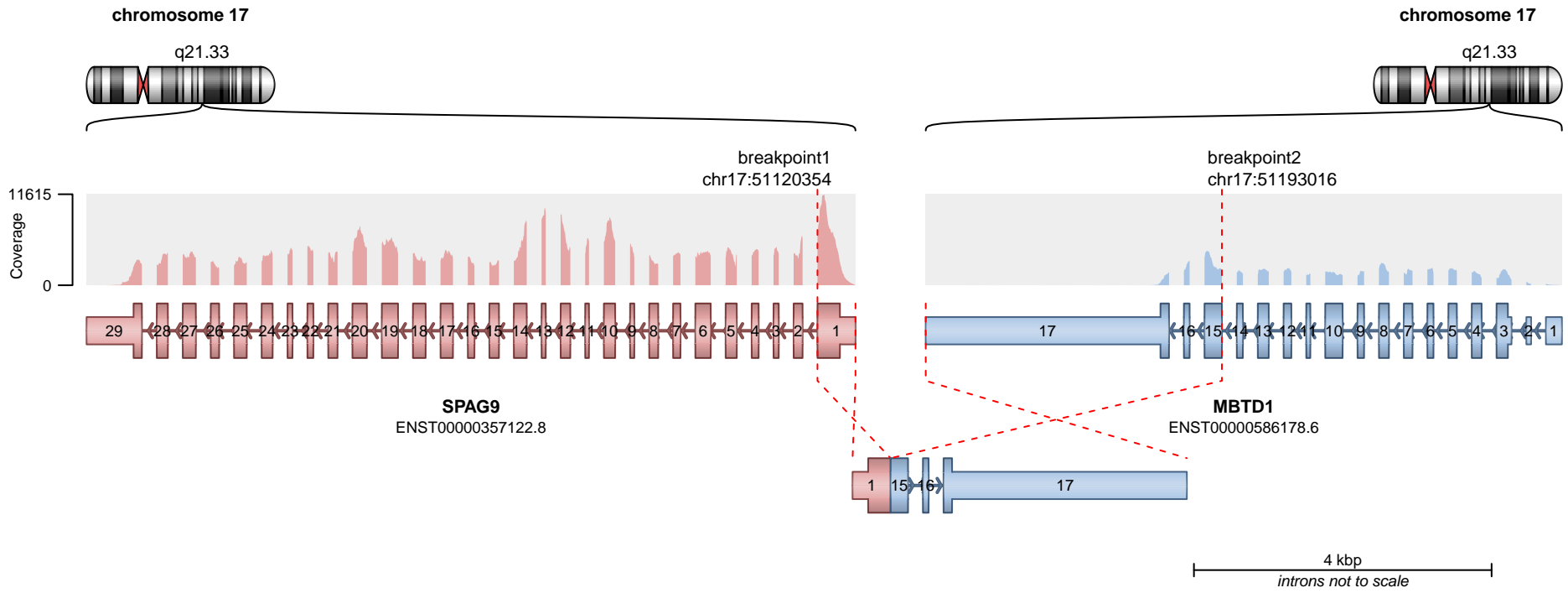

RETAINED PROTEIN DOMAINS
reading frame unclear

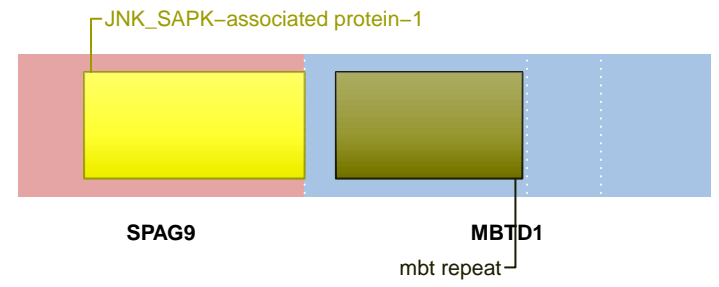

SUPPORTING READ COUNT

Split reads = 6
Discordant mates = 0

- translocation
- duplication
- deletion
- inversion

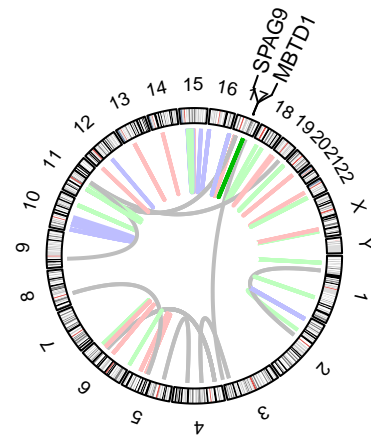
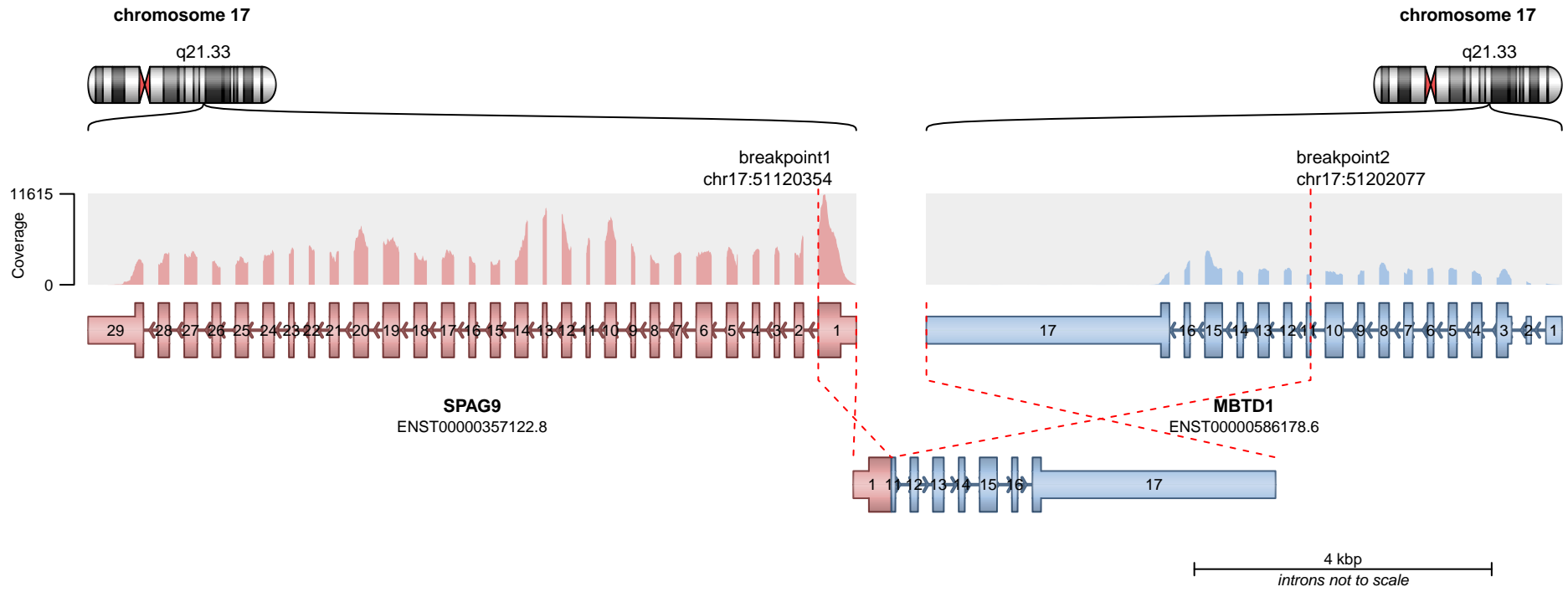

RETAINED PROTEIN DOMAINS
reading frame unclear

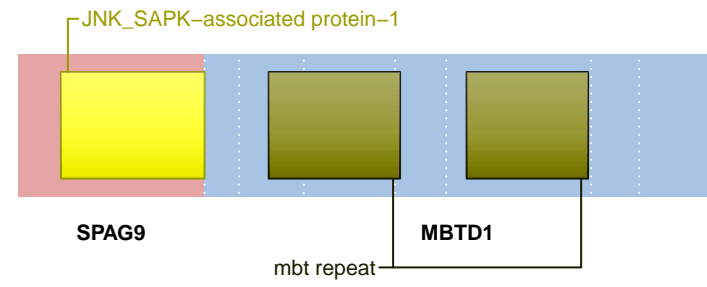

SUPPORTING READ COUNT

Split reads = 5
Discordant mates = 0

- translocation
- duplication
- deletion
- inversion

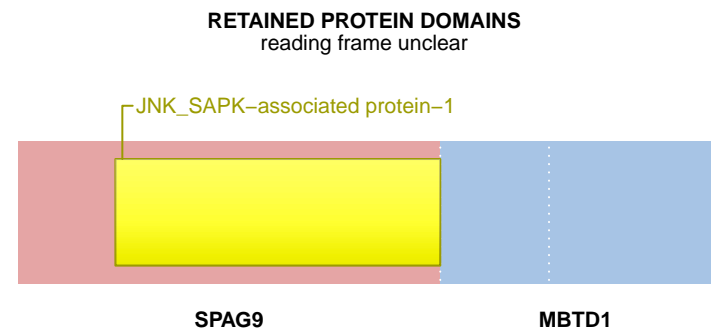
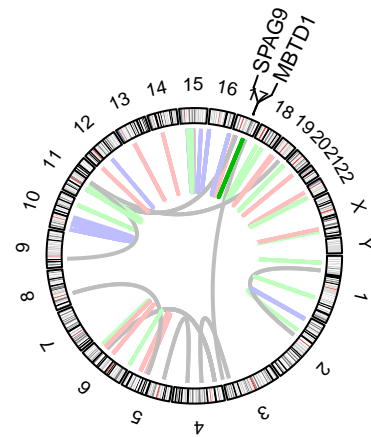
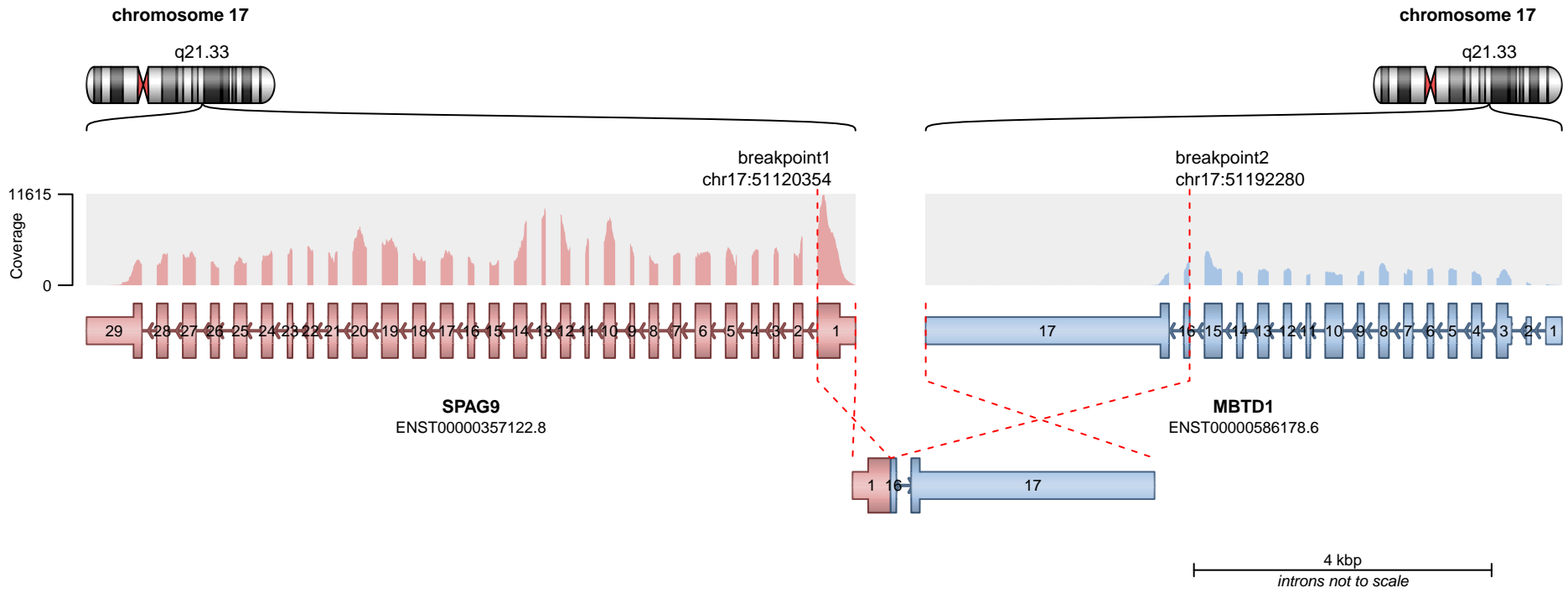

SUPPORTING READ COUNT

Split reads = 4
Discordant mates = 0

— translocation — deletion
— duplication — inversion

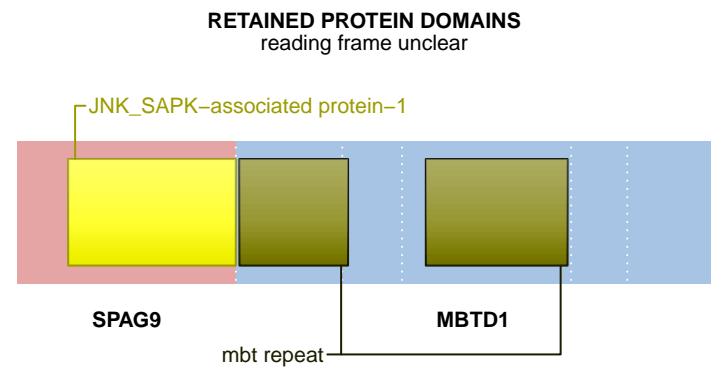
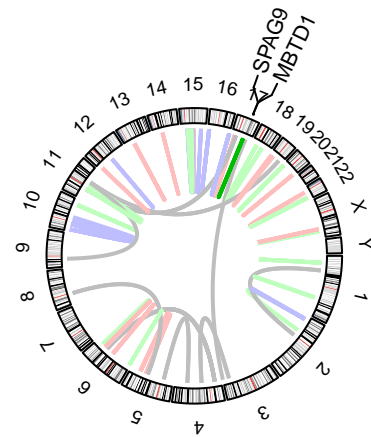
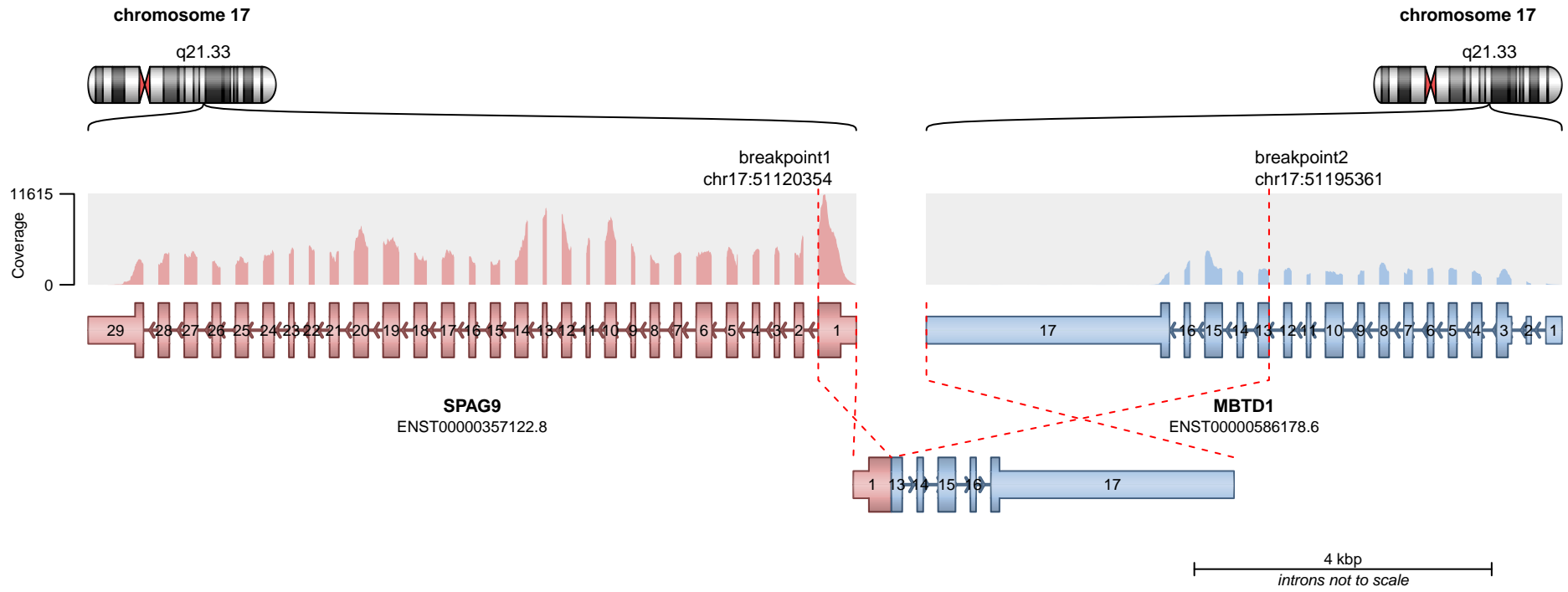

SUPPORTING READ COUNT

Split reads = 2
Discordant mates = 0

— translocation — deletion
— duplication — inversion

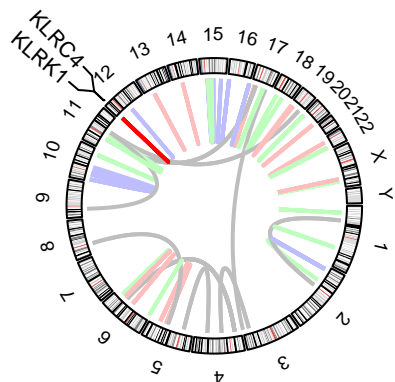
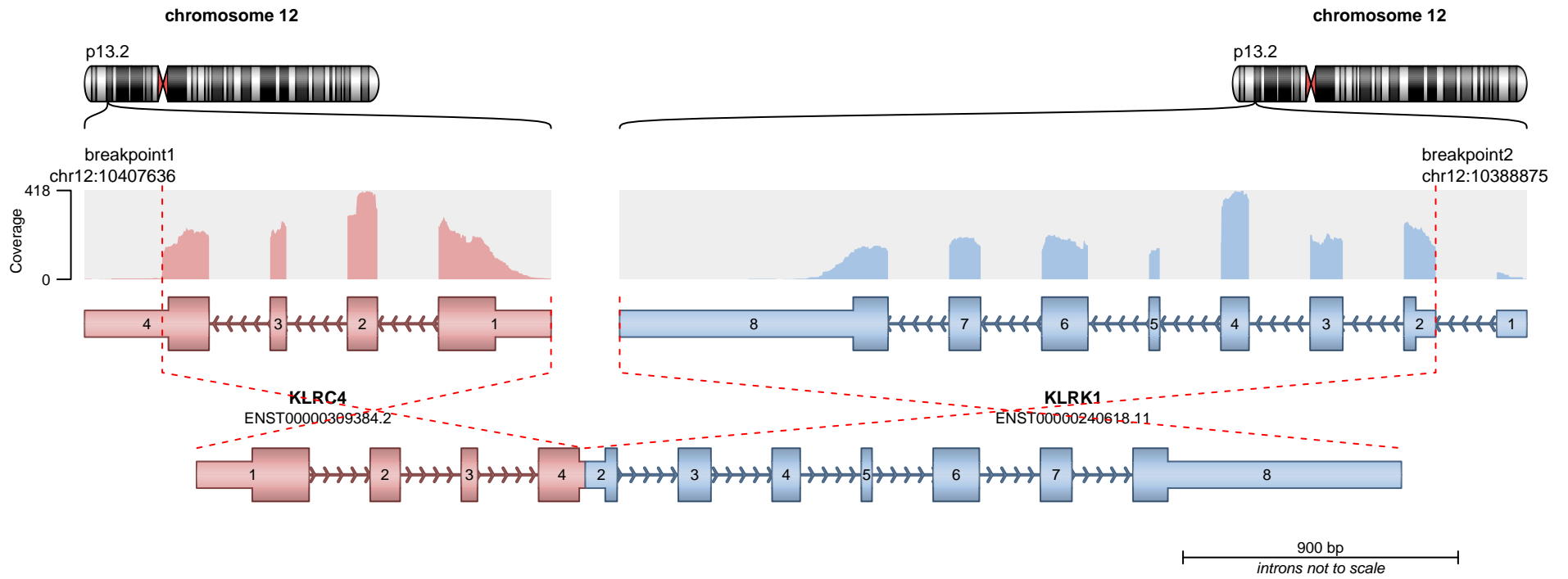

RETAINED PROTEIN DOMAINS
reading frame unclear

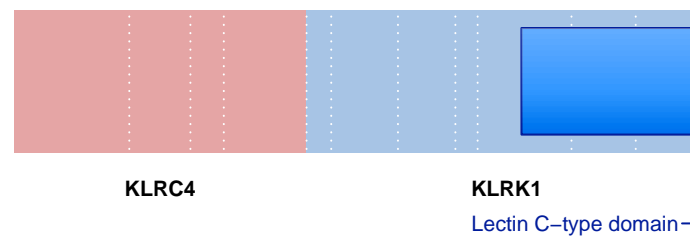

SUPPORTING READ COUNT

Split reads = 37
Discordant mates = 0

— translocation — deletion
— duplication — inversion

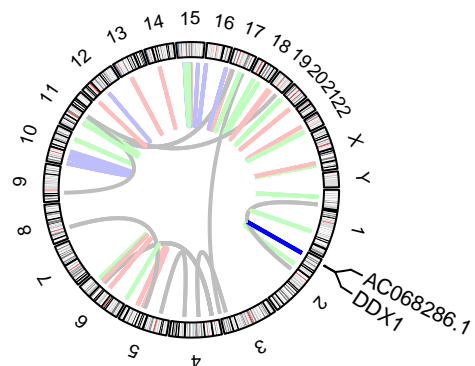
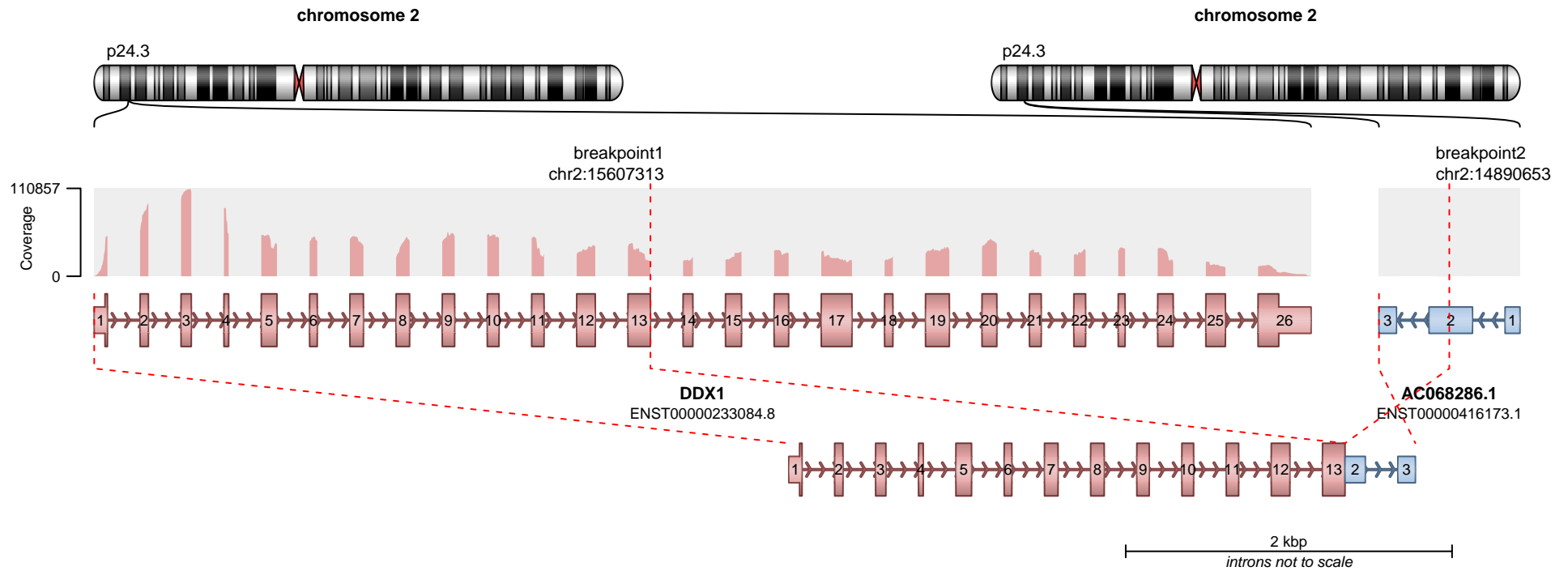

RETAINED PROTEIN DOMAINS
reading frame unclear

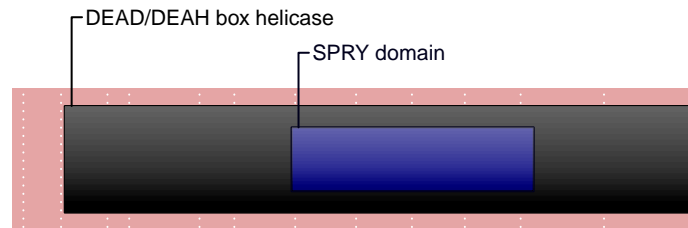

DDX1

SUPPORTING READ COUNT

Split reads = 35
Discordant mates = 7

- translocation
- deletion
- duplication
- inversion

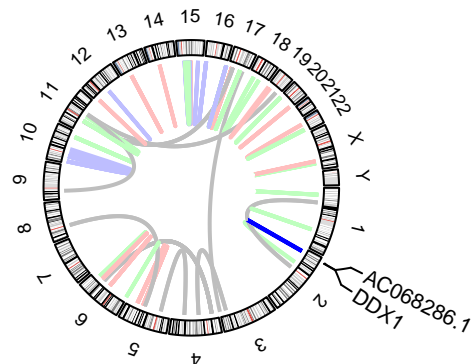
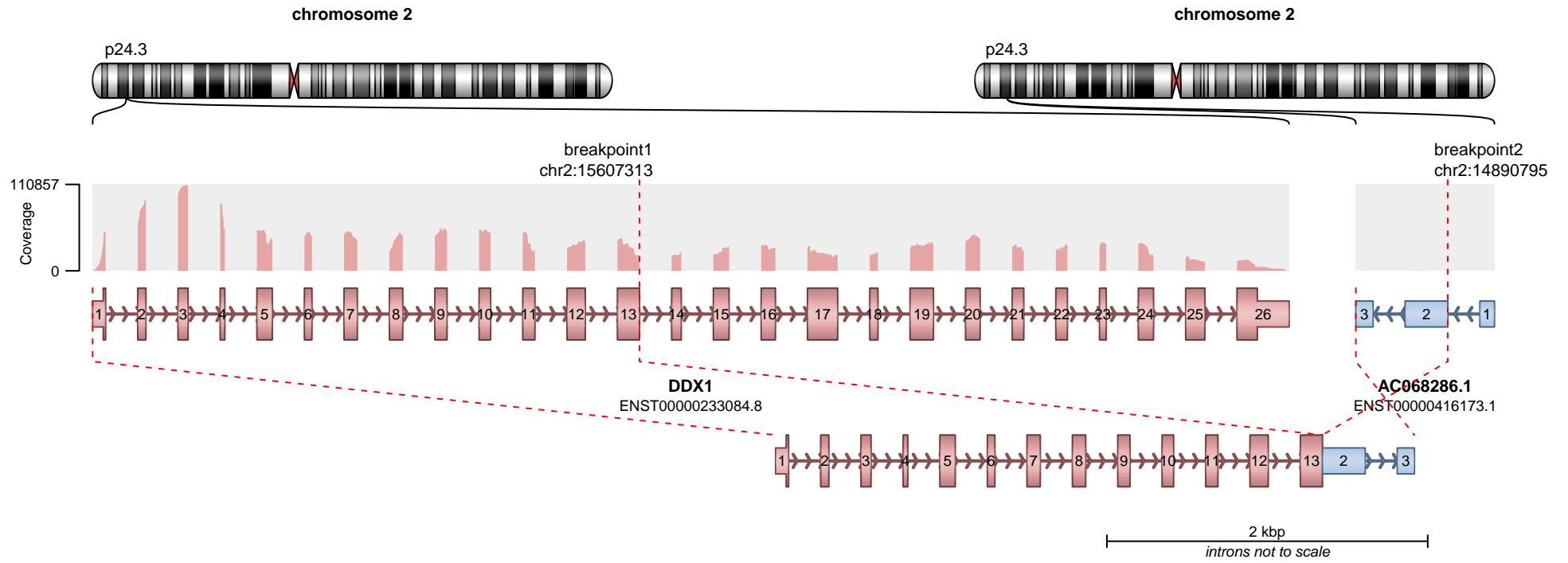

RETAINED PROTEIN DOMAINS
reading frame unclear

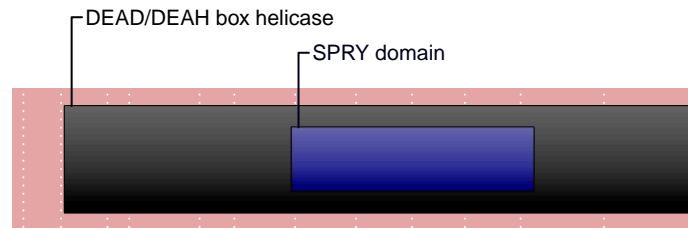

SUPPORTING READ COUNT

Split reads = 30
Discordant mates = 12

- translocation
- duplication
- deletion
- inversion

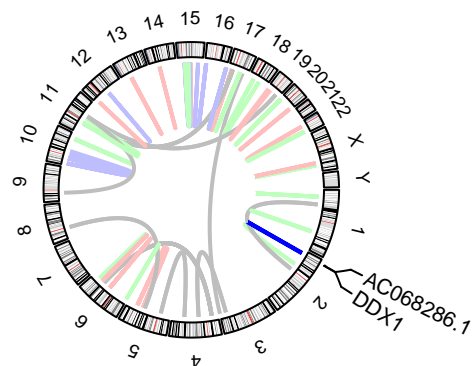
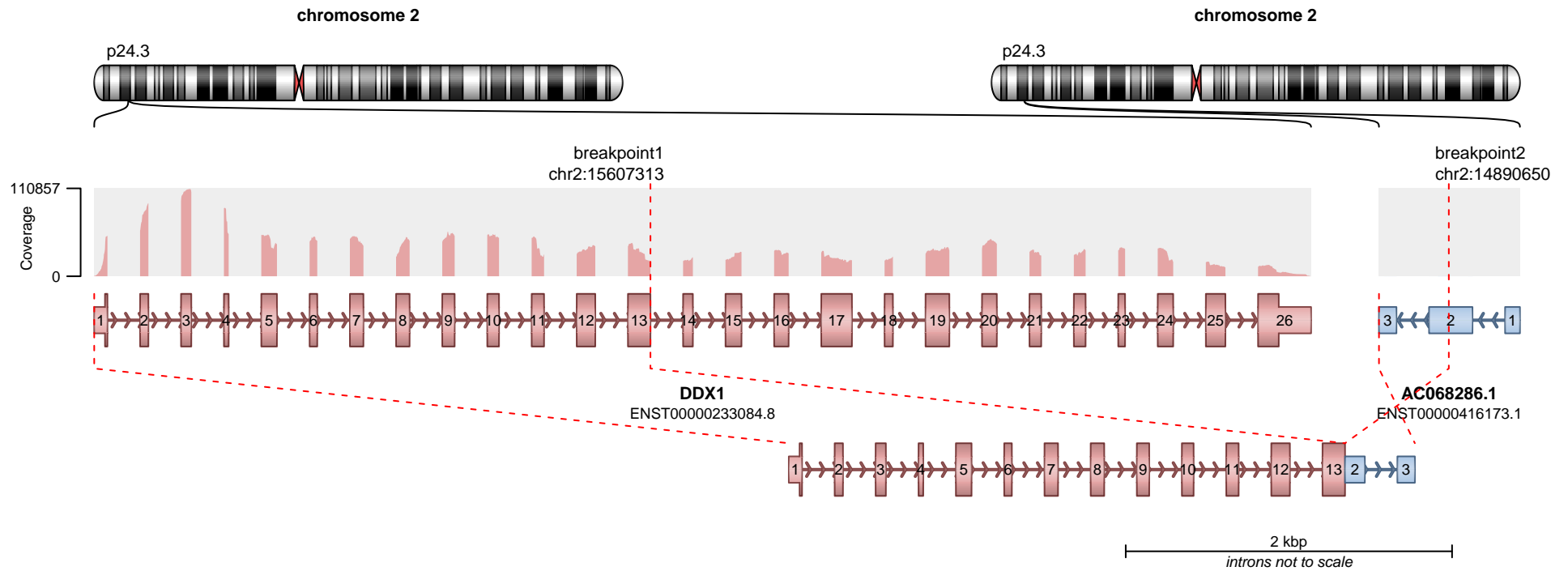

RETAINED PROTEIN DOMAINS
reading frame unclear

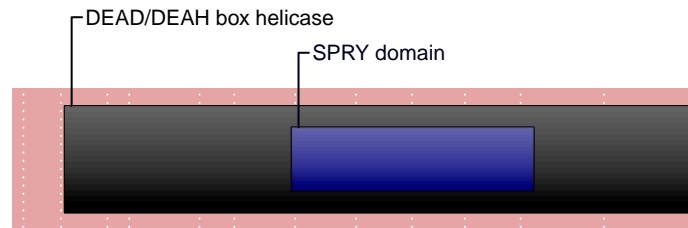

DDX1

SUPPORTING READ COUNT

Split reads = 22
Discordant mates = 7

- translocation
- duplication
- deletion
- inversion

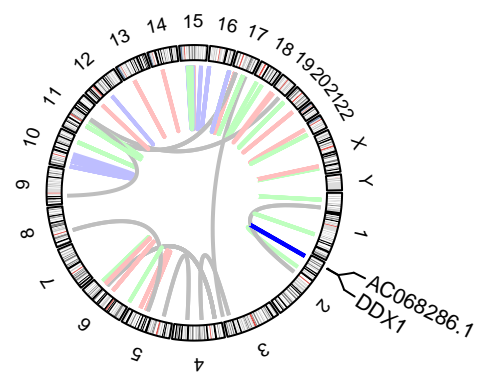
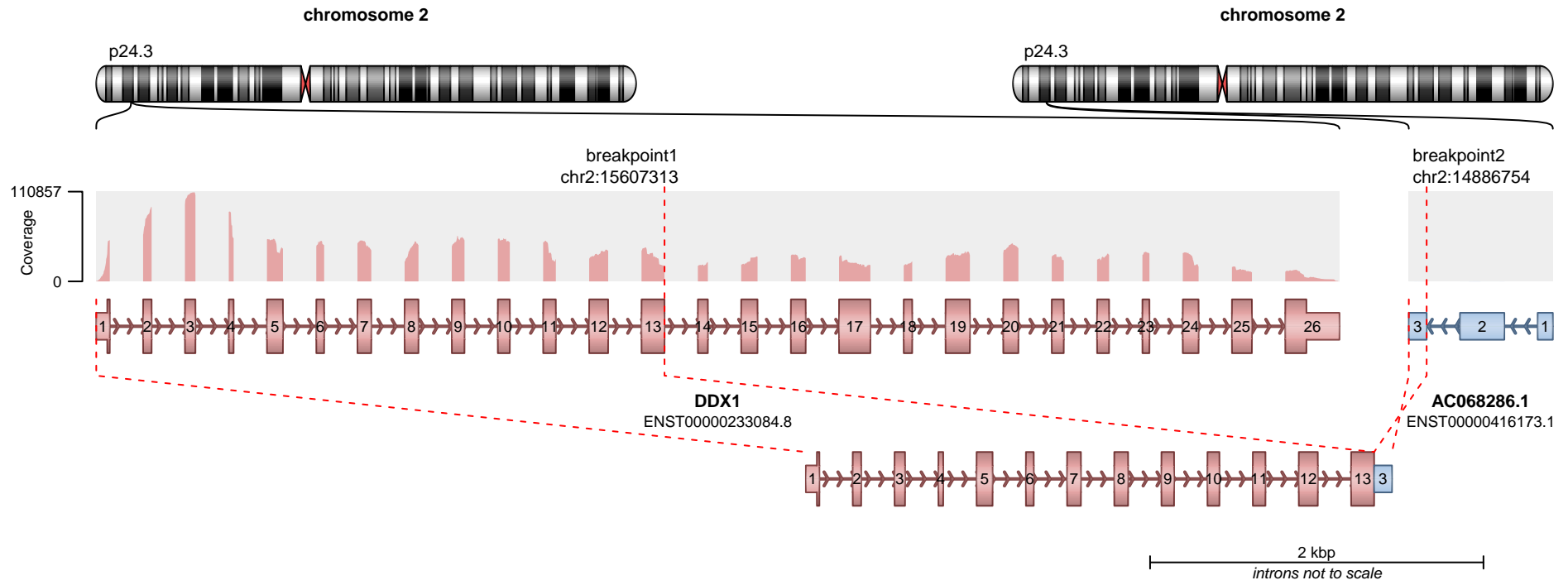

RETAINED PROTEIN DOMAINS
reading frame unclear

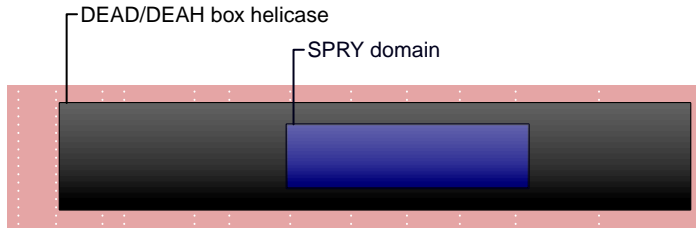

SUPPORTING READ COUNT

Split reads = 18
Discordant mates = 2

- translocation
- duplication
- deletion
- inversion

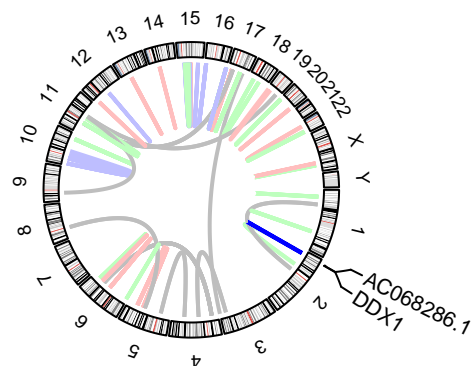
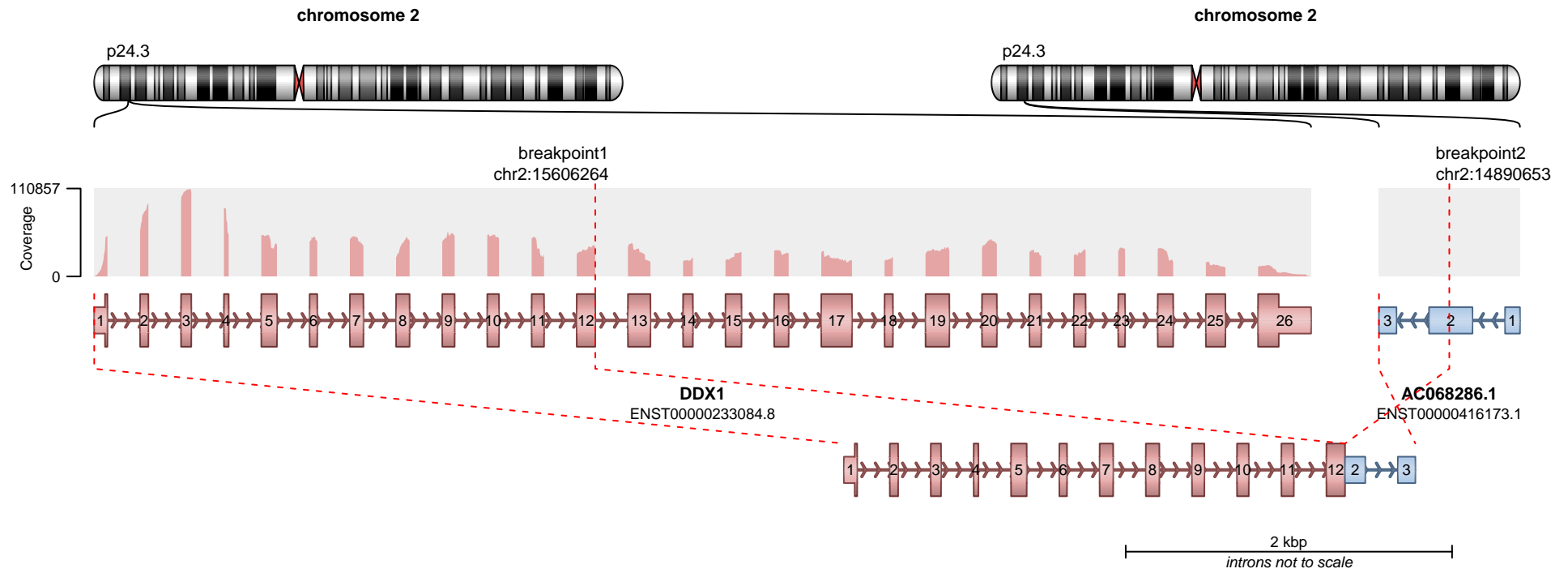

RETAINED PROTEIN DOMAINS
reading frame unclear

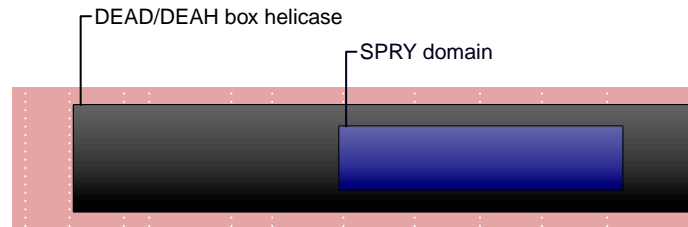

SUPPORTING READ COUNT

Split reads = 5
Discordant mates = 2

— translocation — deletion
— duplication — inversion

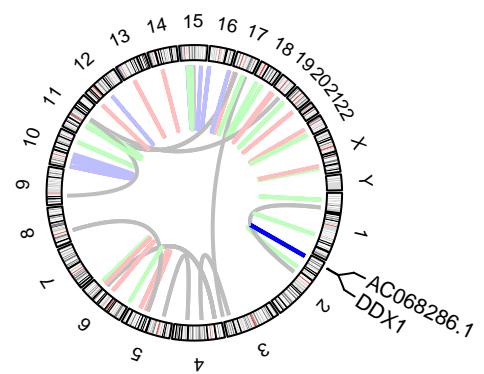
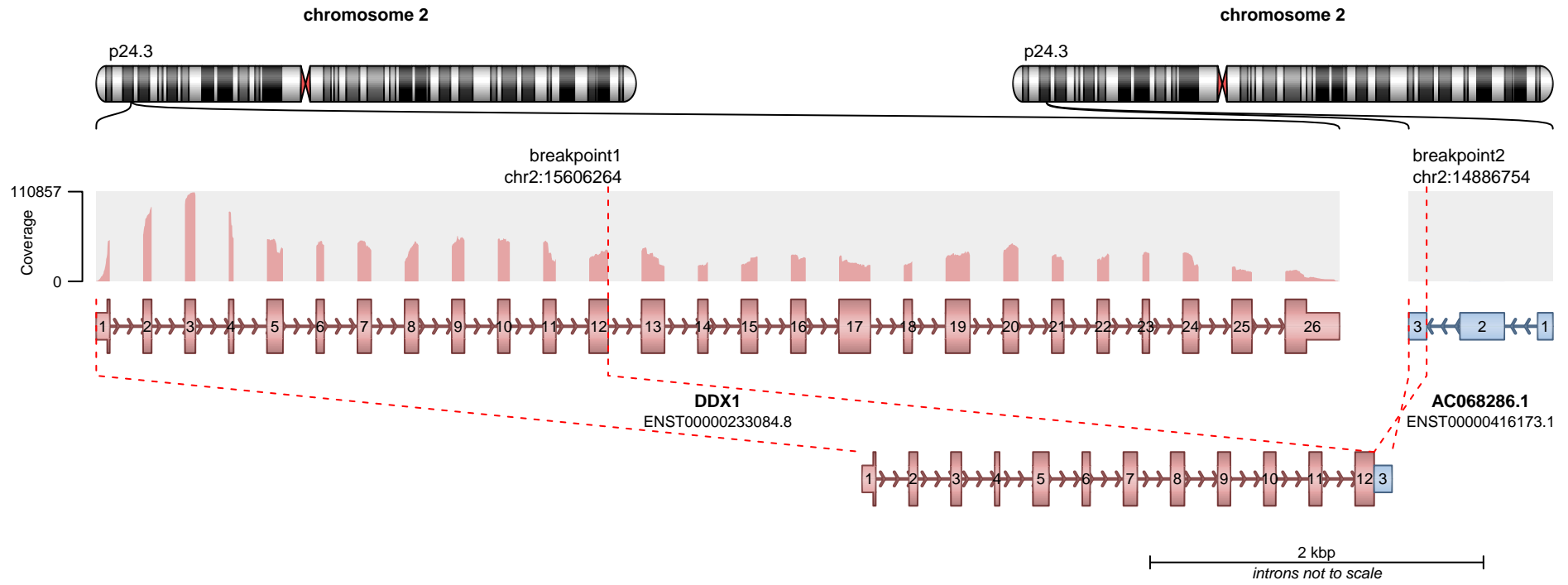

RETAINED PROTEIN DOMAINS
reading frame unclear

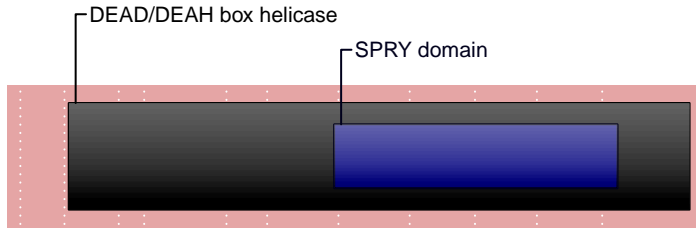

SUPPORTING READ COUNT

Split reads = 1
Discordant mates = 1

- translocation
- duplication
- deletion
- inversion

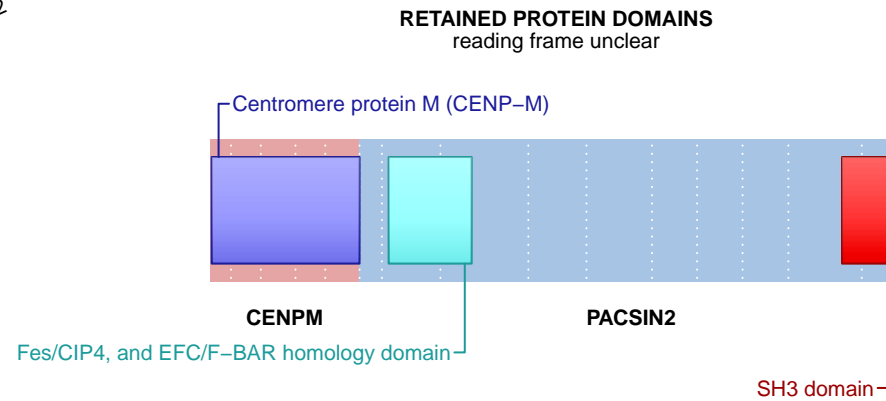
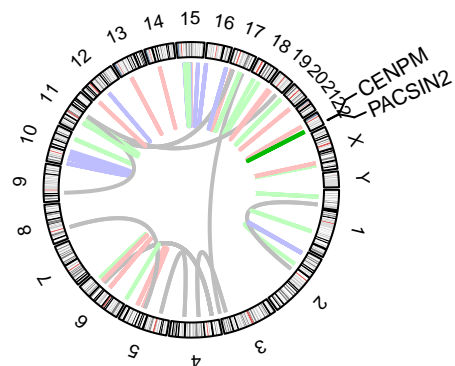
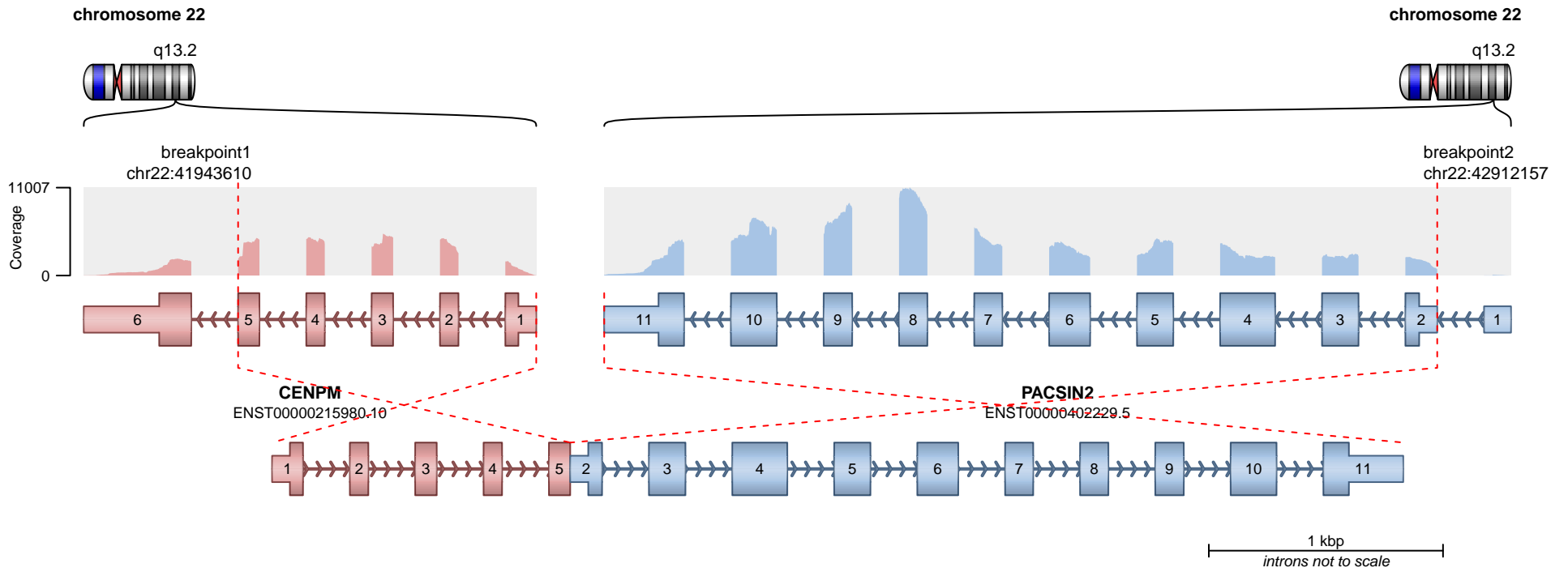

SUPPORTING READ COUNT

Split reads = 29
Discordant mates = 4

— translocation — deletion
— duplication — inversion

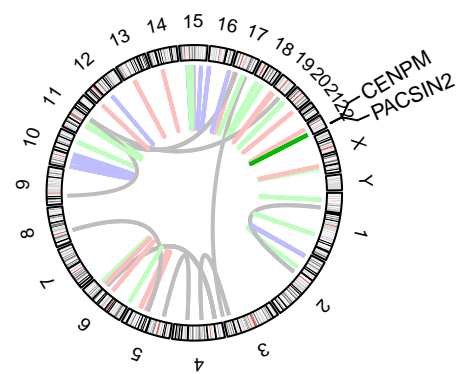
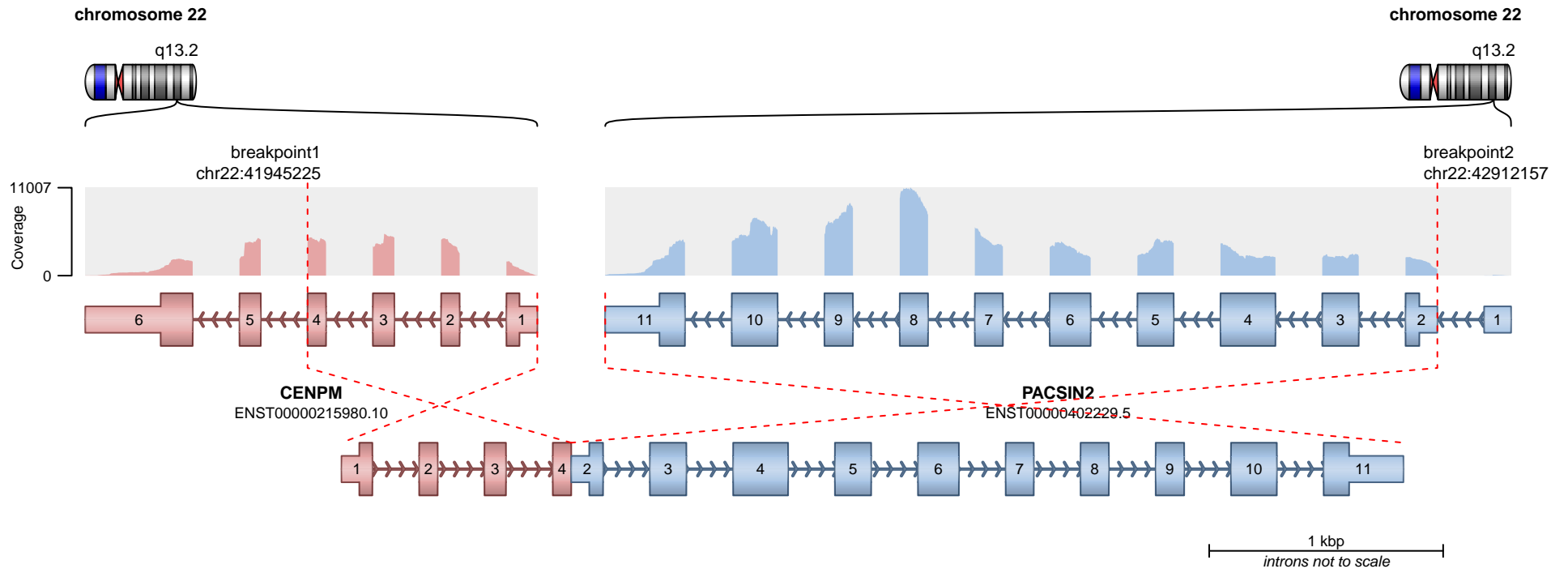

RETAINED PROTEIN DOMAINS
reading frame unclear

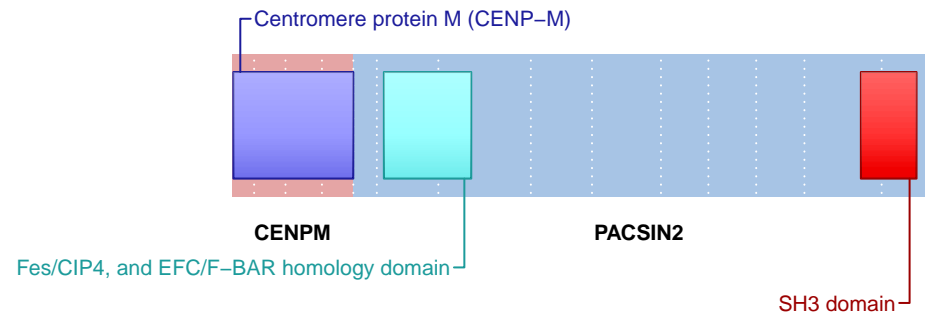

SUPPORTING READ COUNT

Split reads = 12
Discordant mates = 0

- translocation
- duplication
- deletion
- inversion

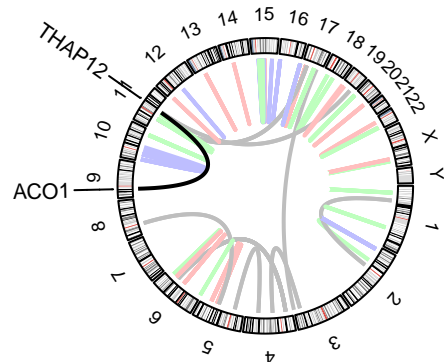
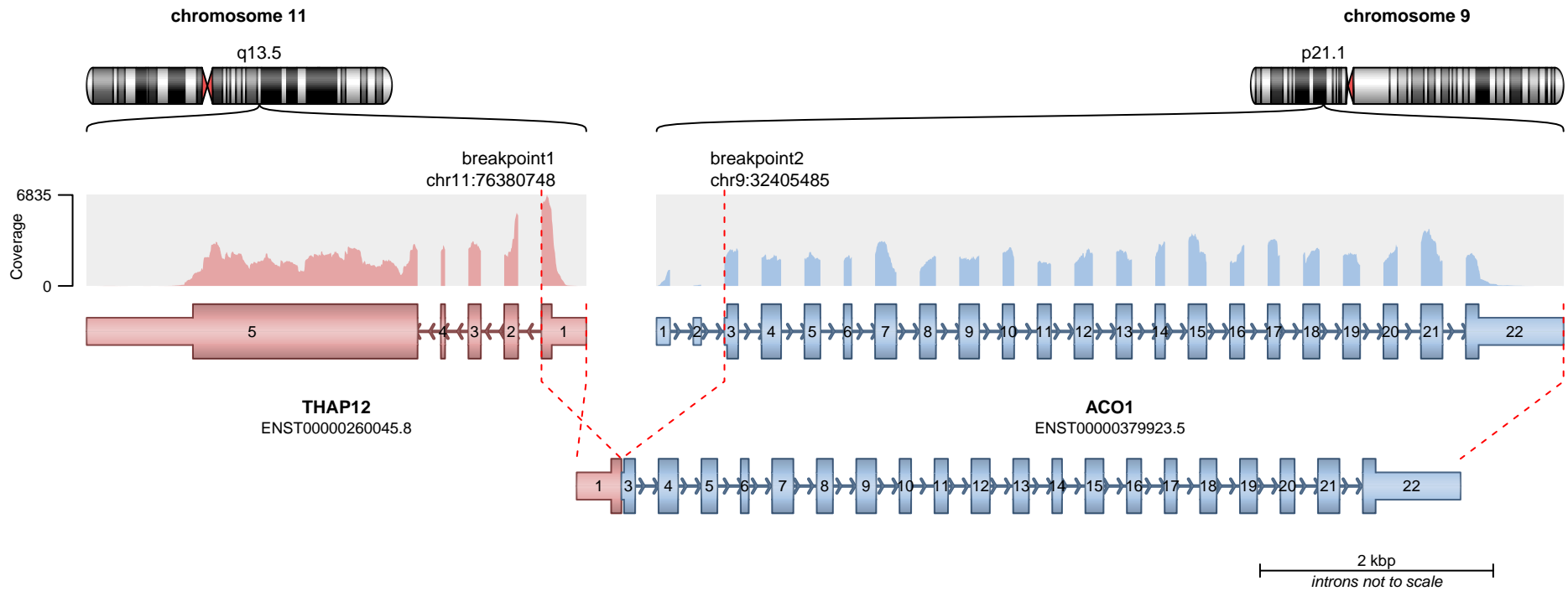

RETAINED PROTEIN DOMAINS
reading frame unclear

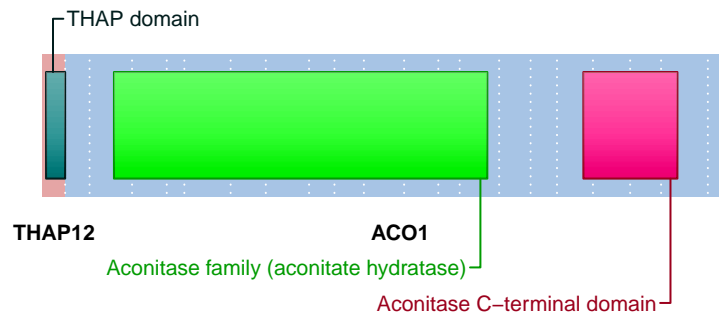

SUPPORTING READ COUNT

Split reads = 29
Discordant mates = 1

— translocation — deletion
— duplication — inversion

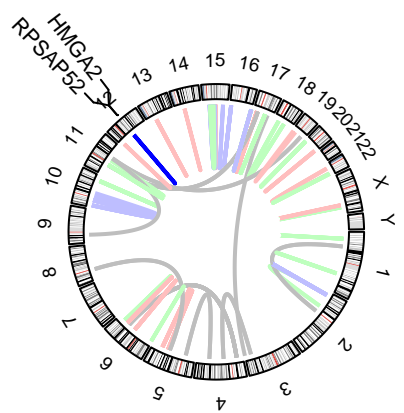
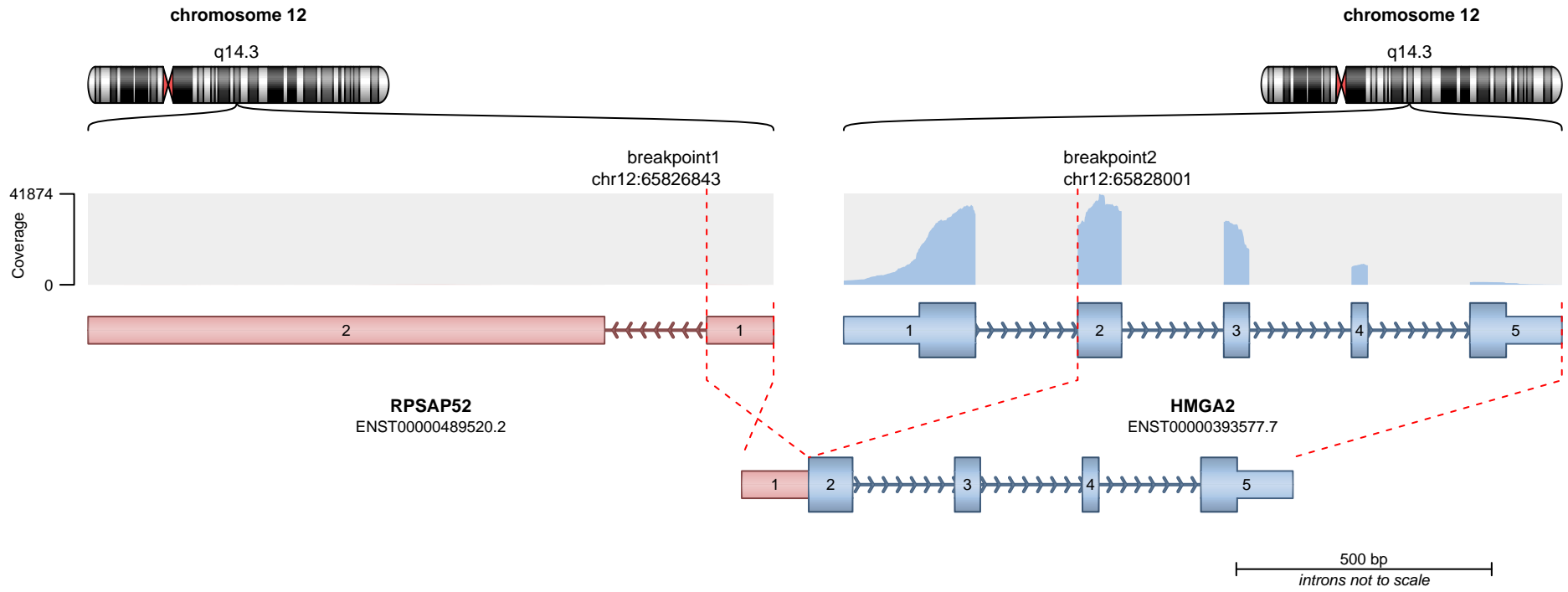

RETAINED PROTEIN DOMAINS
reading frame unclear

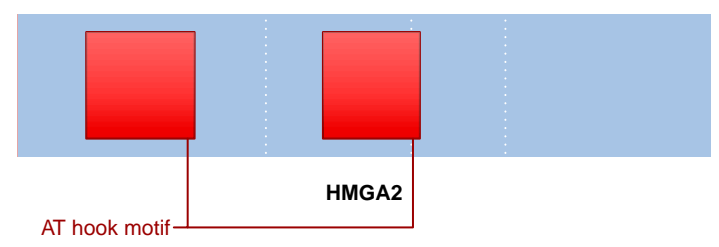

SUPPORTING READ COUNT

Split reads = 26
Discordant mates = 1

— translocation — deletion
— duplication — inversion

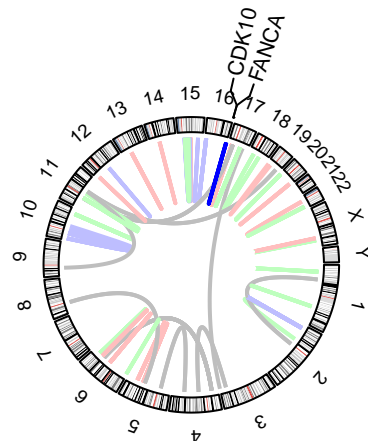
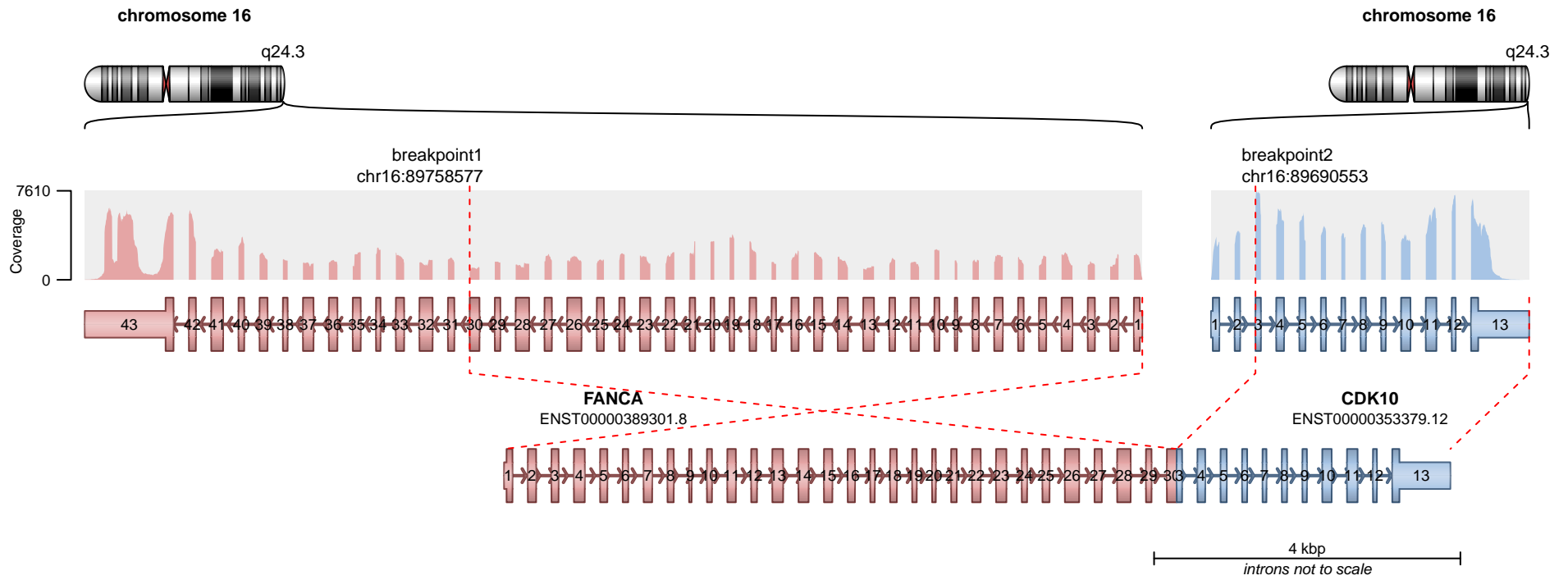

RETAINED PROTEIN DOMAINS
reading frame unclear

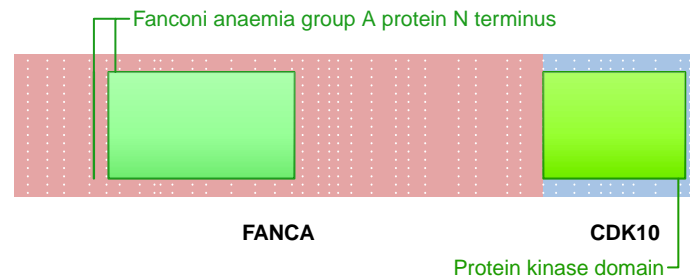

SUPPORTING READ COUNT

Split reads = 26
Discordant mates = 0

- translocation
- duplication
- deletion
- inversion

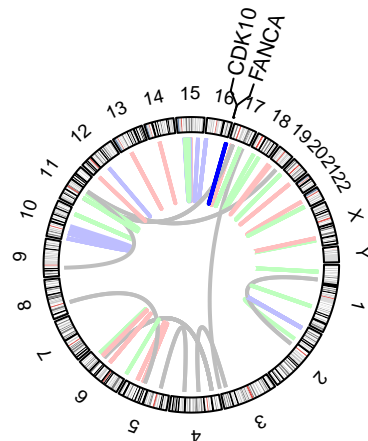
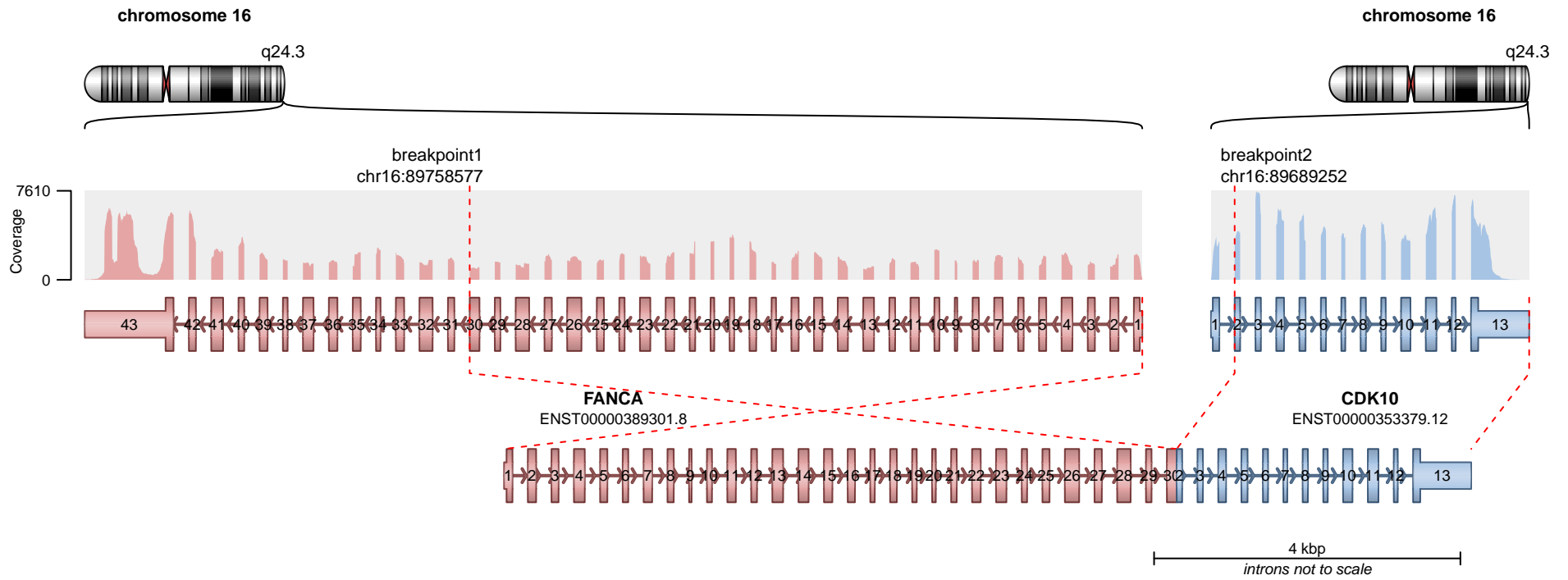

RETAINED PROTEIN DOMAINS
reading frame unclear

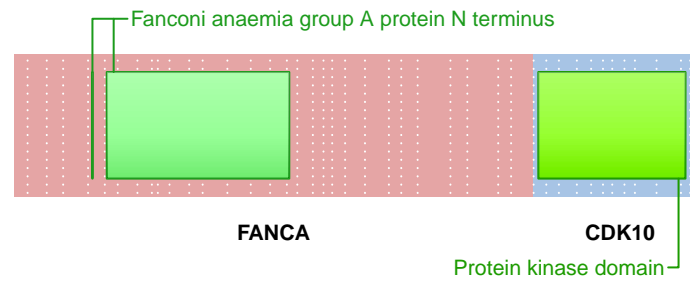

SUPPORTING READ COUNT

Split reads = 10
Discordant mates = 0

- translocation
- duplication
- deletion
- inversion

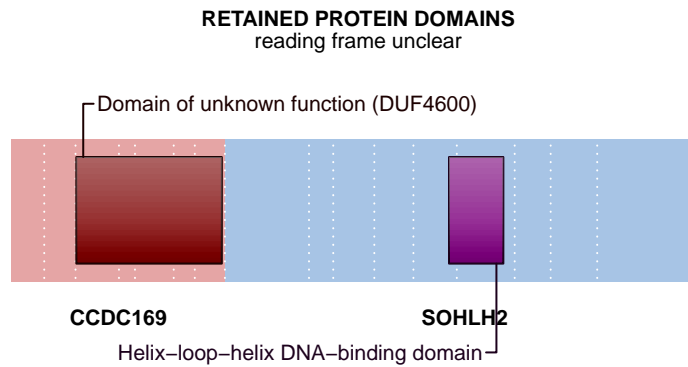
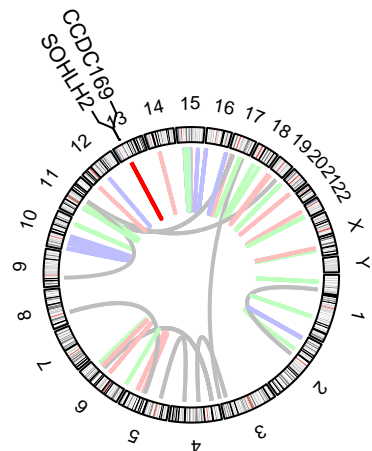
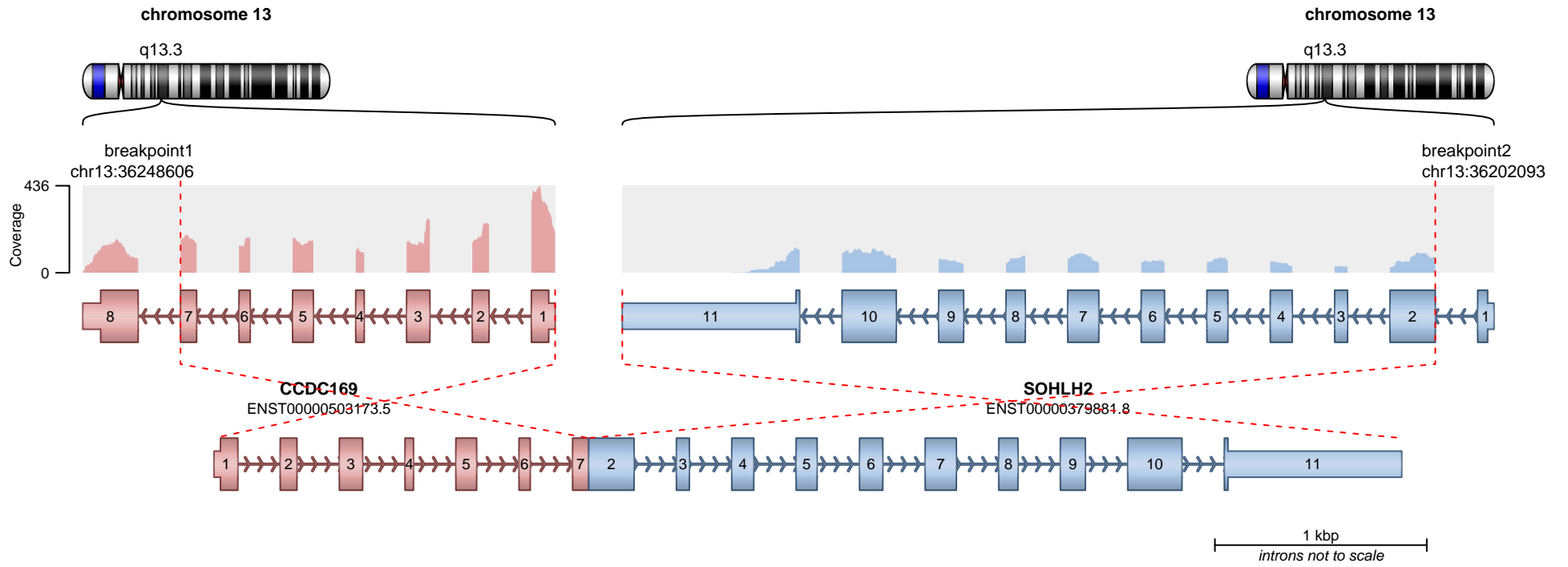

SUPPORTING READ COUNT

Split reads = 22
Discordant mates = 0

— translocation — deletion
— duplication — inversion

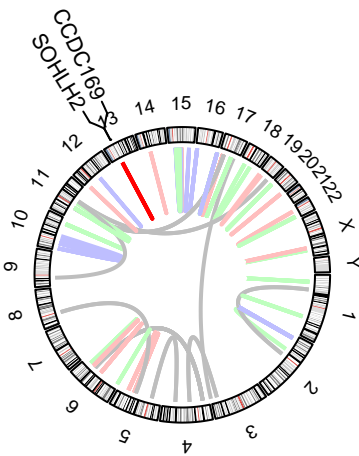
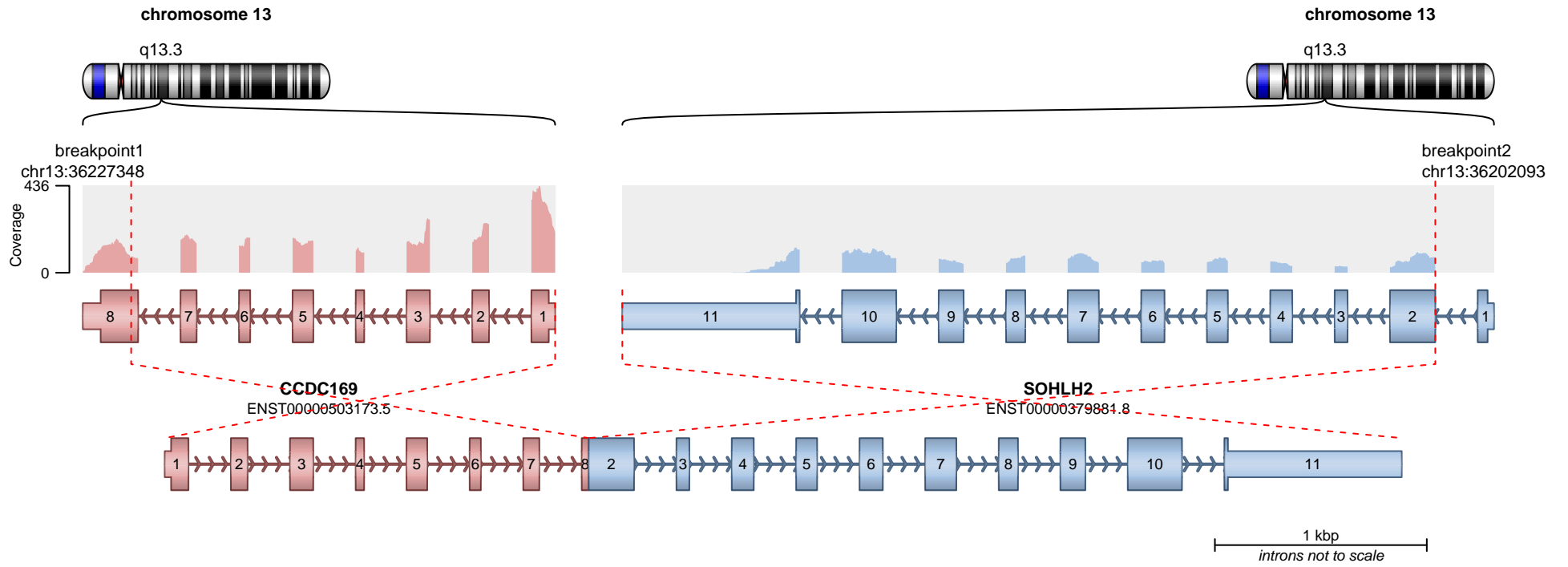

RETAINED PROTEIN DOMAINS
reading frame unclear

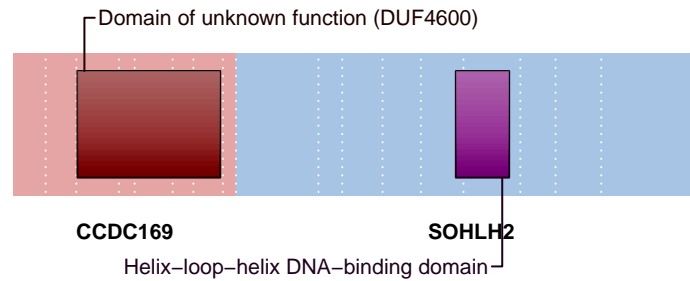

SUPPORTING READ COUNT

Split reads = 4
Discordant mates = 0

- translocation
- duplication
- deletion
- inversion

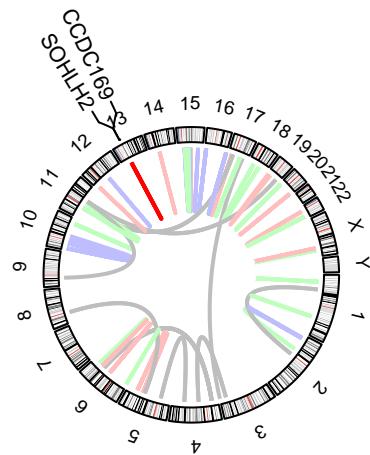
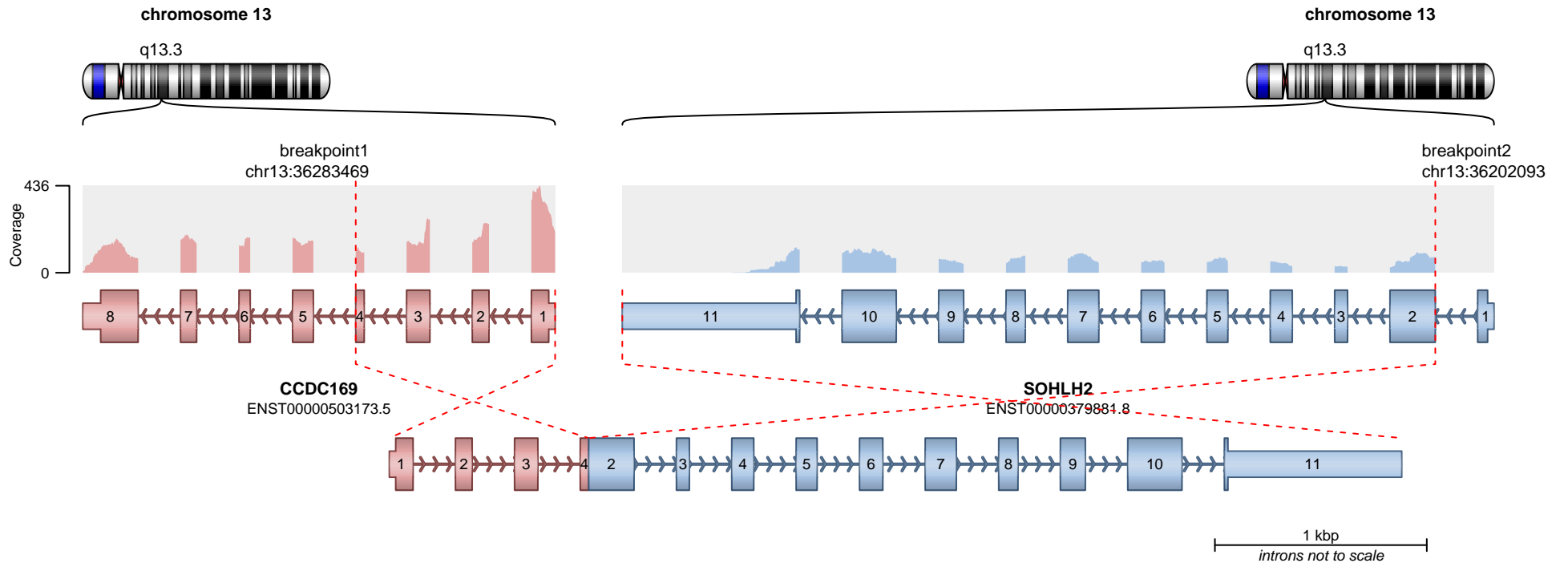

RETAINED PROTEIN DOMAINS
reading frame unclear

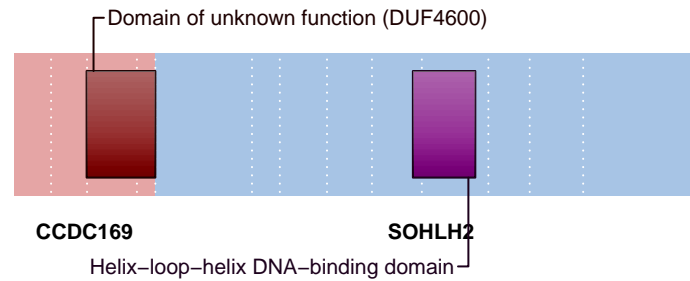

SUPPORTING READ COUNT

Split reads = 2
Discordant mates = 0

— translocation — deletion
— duplication — inversion

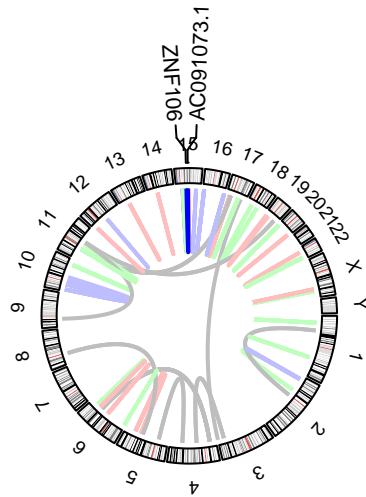
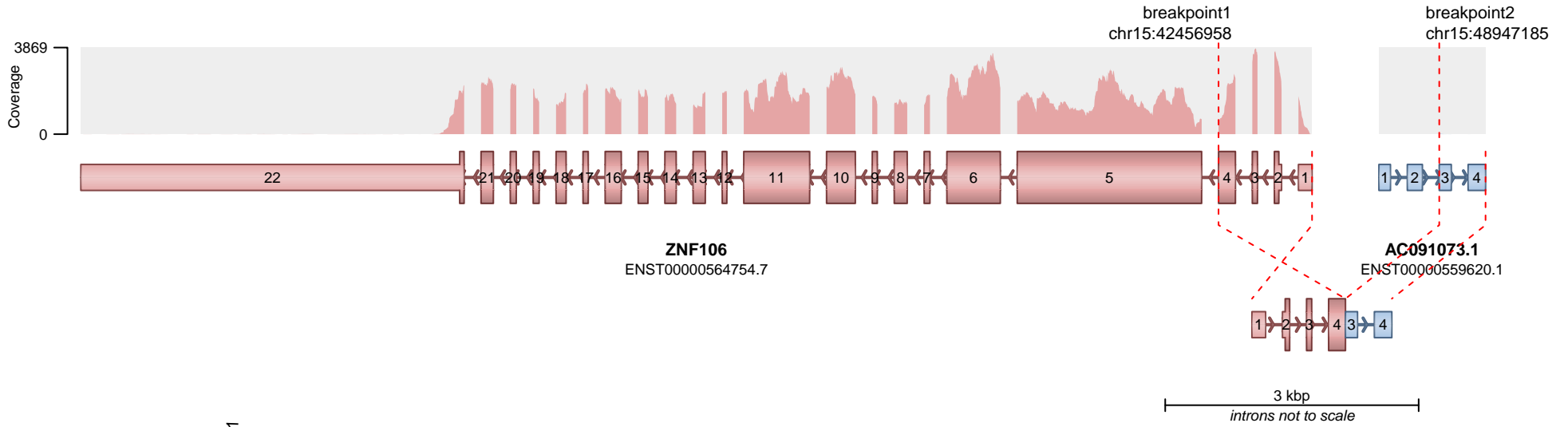
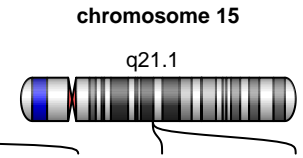
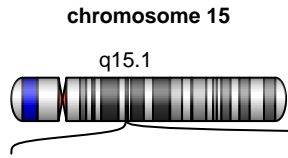

— translocation — deletion
— duplication — inversion

No protein domains retained in fusion.

SUPPORTING READ COUNT

Split reads = 20
Discordant mates = 1

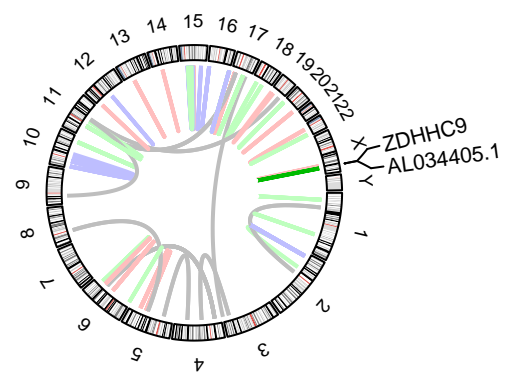
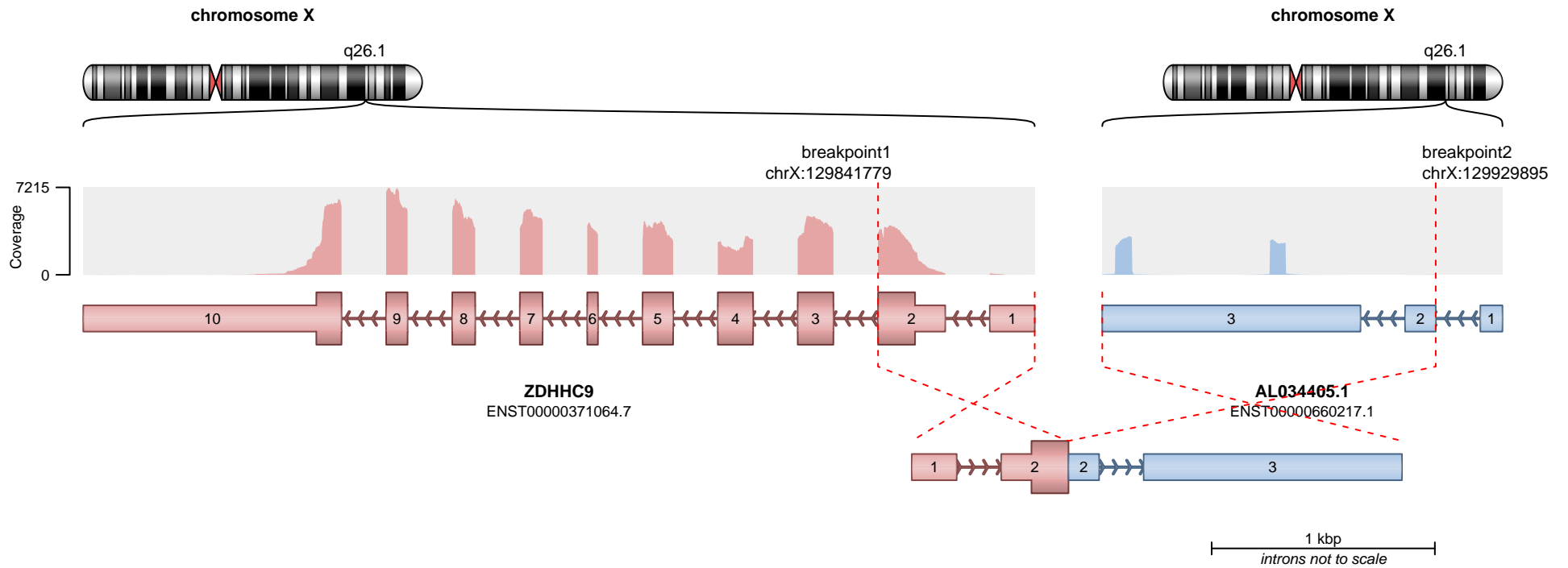

No protein domains retained in fusion.

SUPPORTING READ COUNT

Split reads = 20
Discordant mates = 0

- translocation
- duplication
- deletion
- inversion

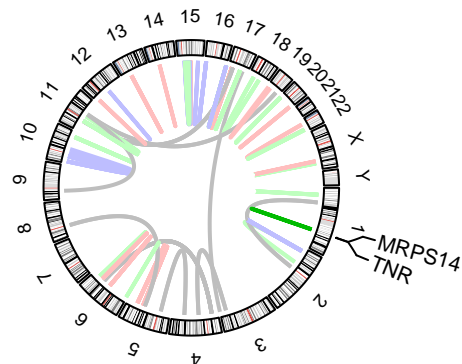
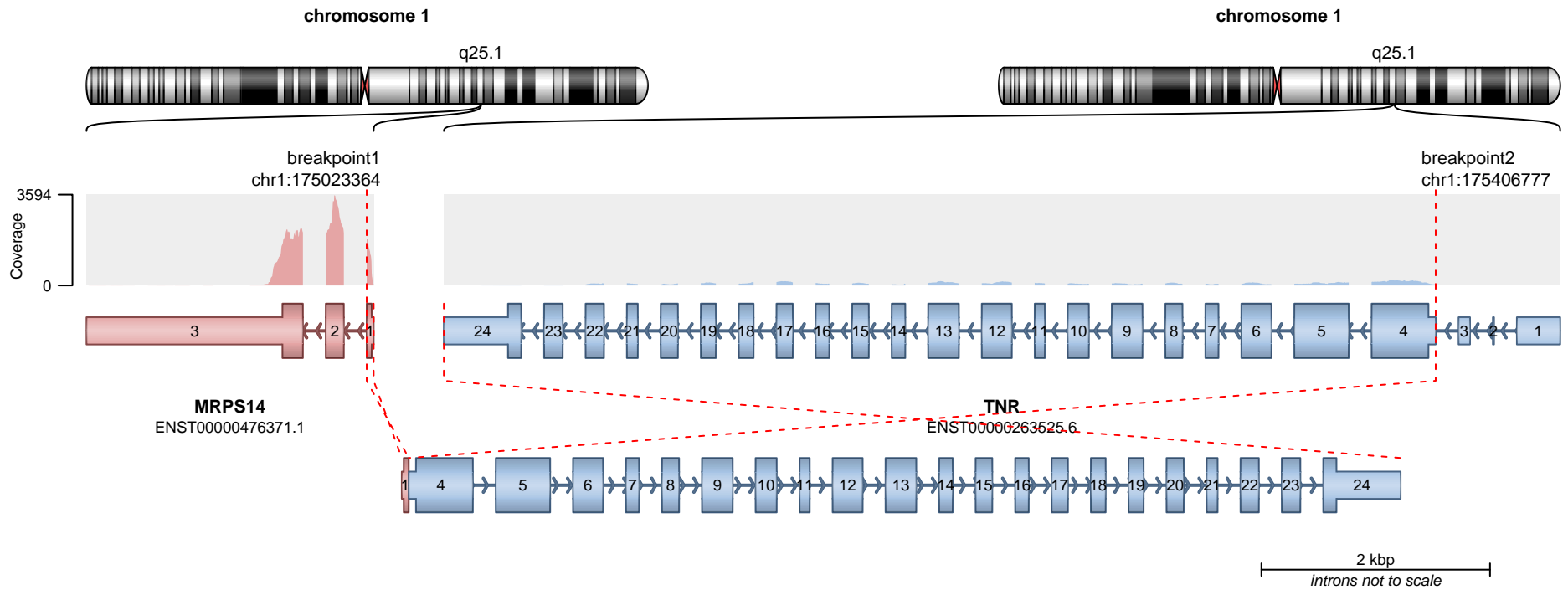

— translocation — deletion
— duplication — inversion

RETAINED PROTEIN DOMAINS
reading frame unclear

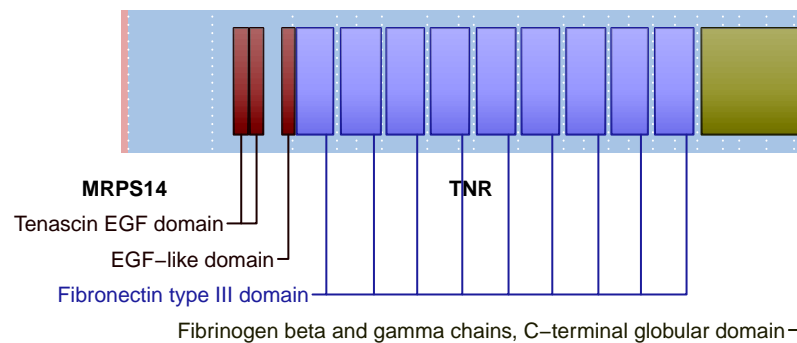

SUPPORTING READ COUNT

Split reads = 15
Discordant mates = 0

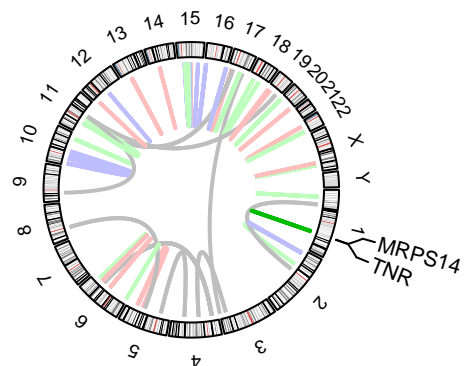
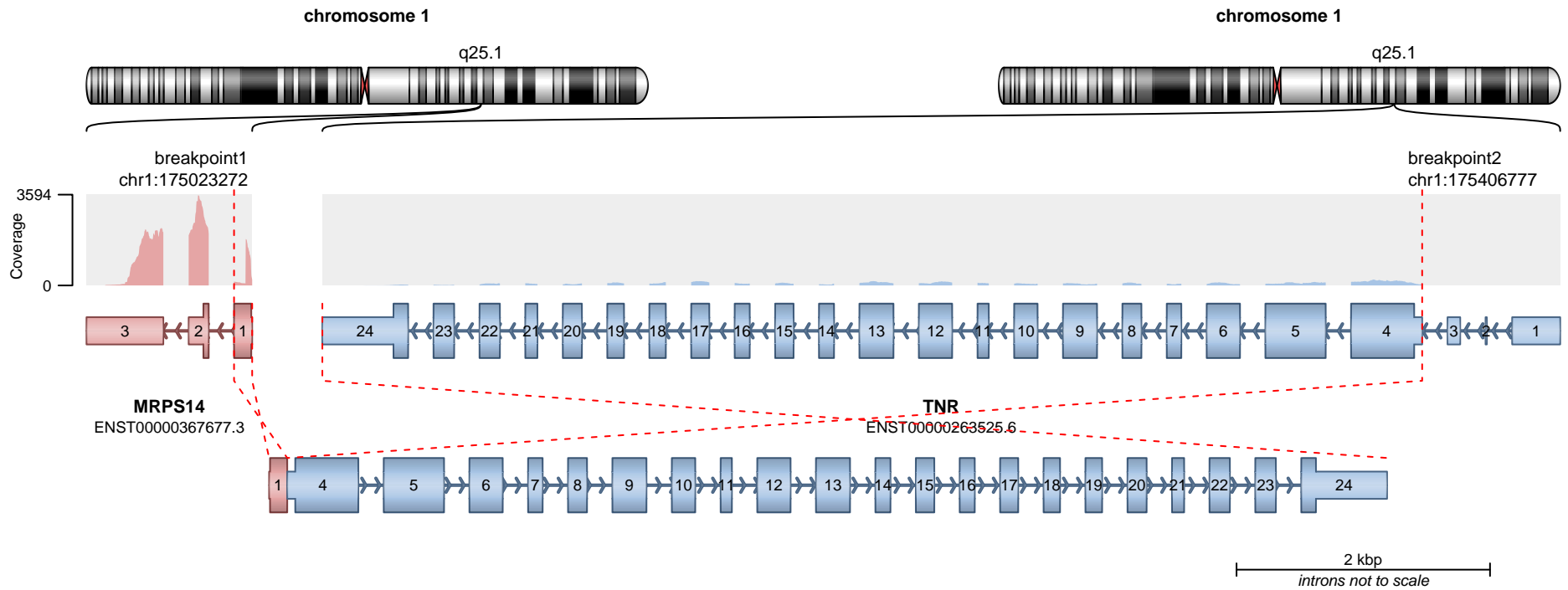

— translocation — deletion
— duplication — inversion

RETAINED PROTEIN DOMAINS
reading frame unclear

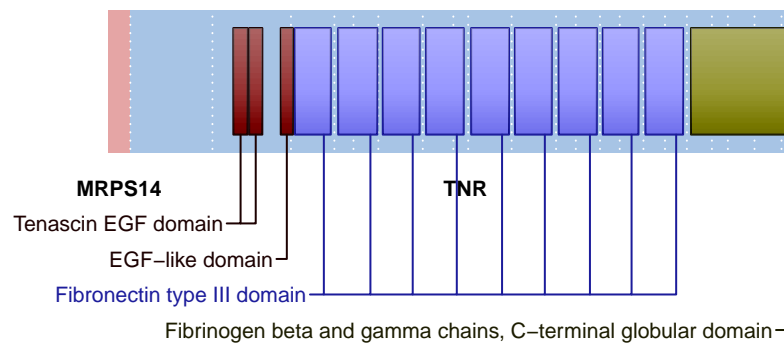

SUPPORTING READ COUNT

Split reads = 4
Discordant mates = 0

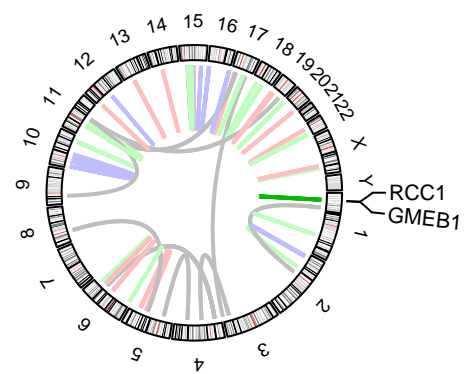
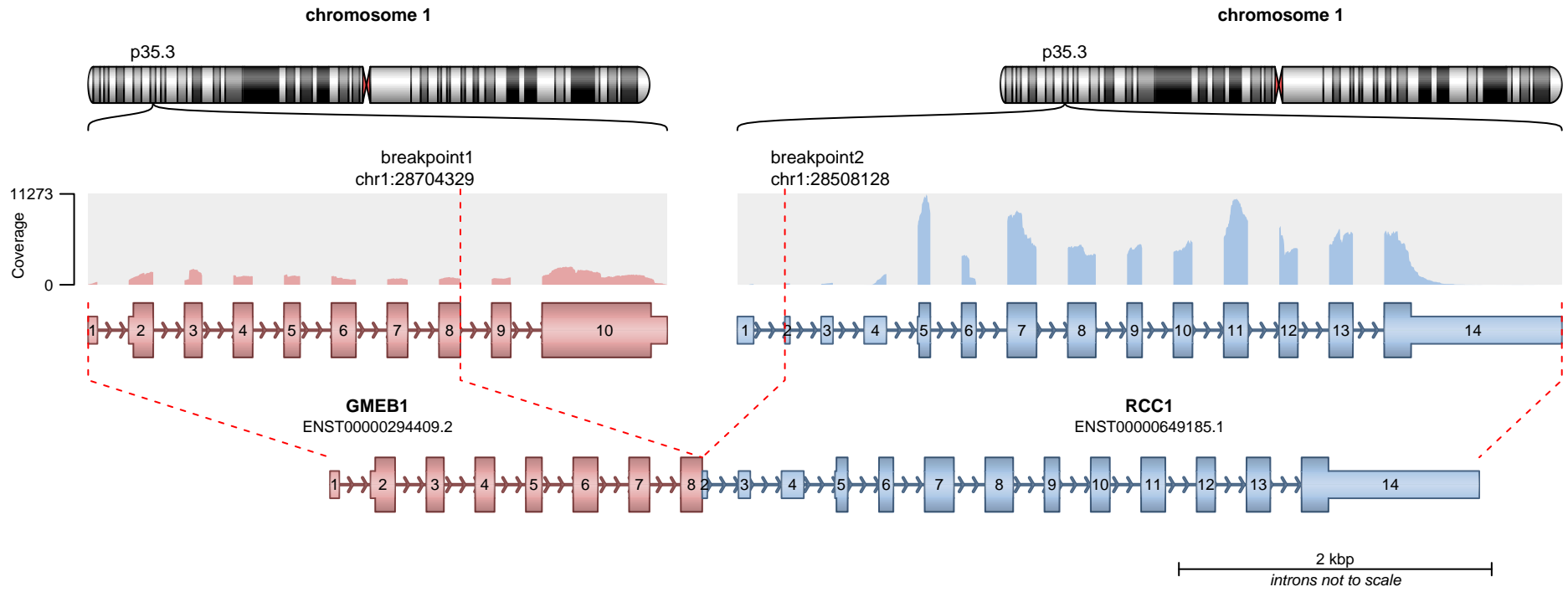

RETAINED PROTEIN DOMAINS
reading frame unclear

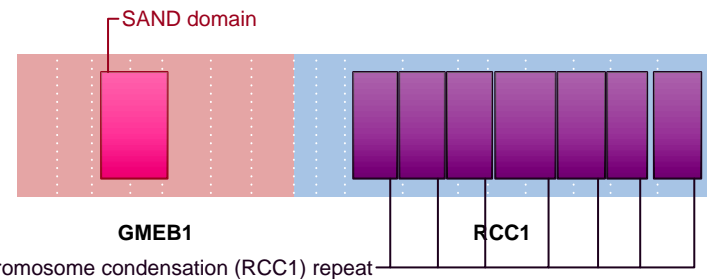

SUPPORTING READ COUNT

Split reads = 14
Discordant mates = 2

- translocation
- duplication
- deletion
- inversion

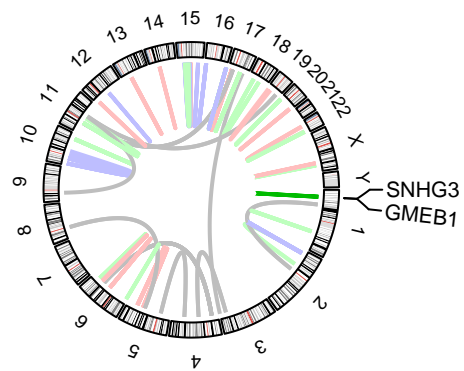
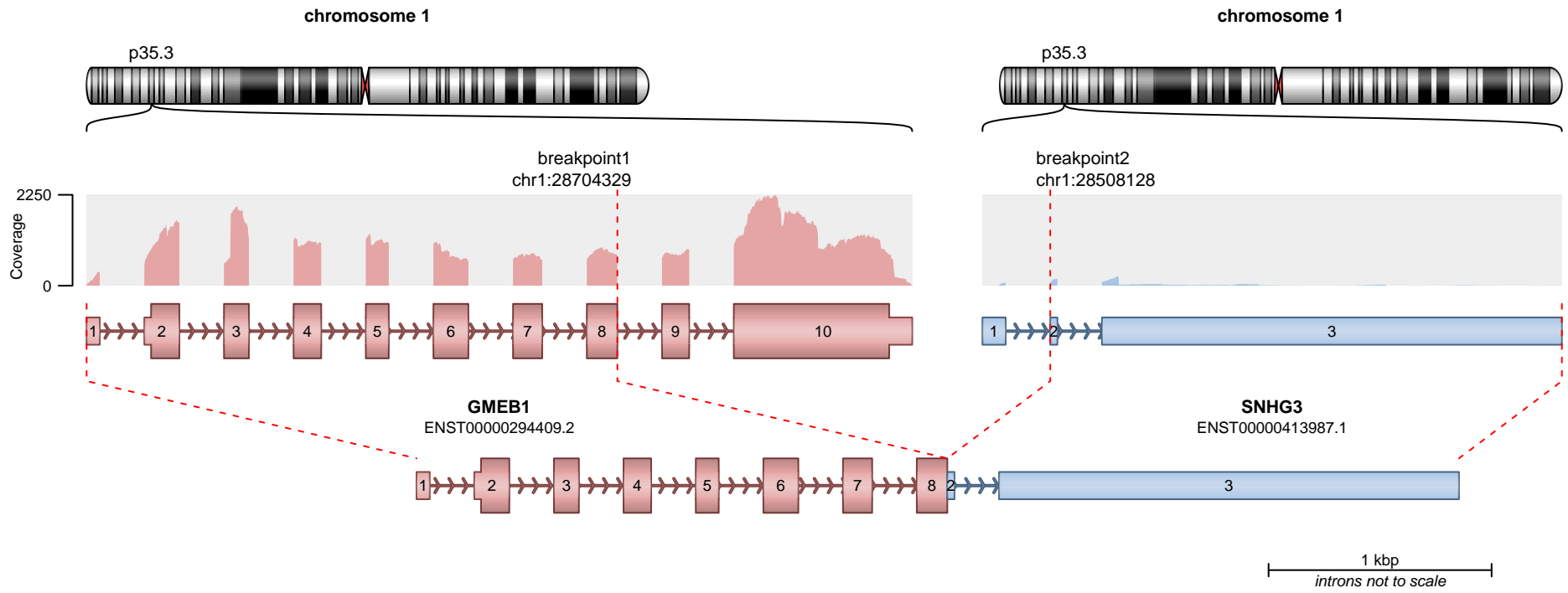

RETAINED PROTEIN DOMAINS
reading frame unclear

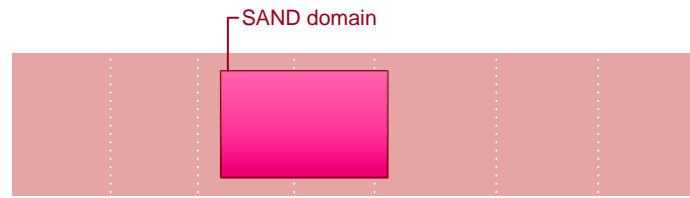

SUPPORTING READ COUNT

Split reads = 14
Discordant mates = 2

- translocation
- duplication
- deletion
- inversion

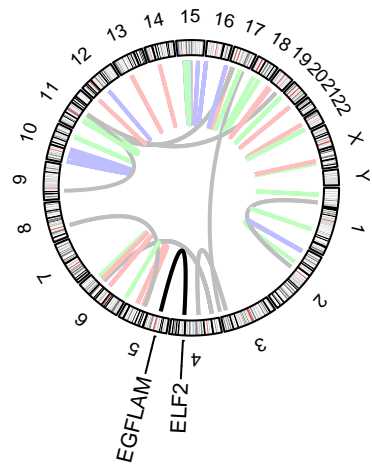
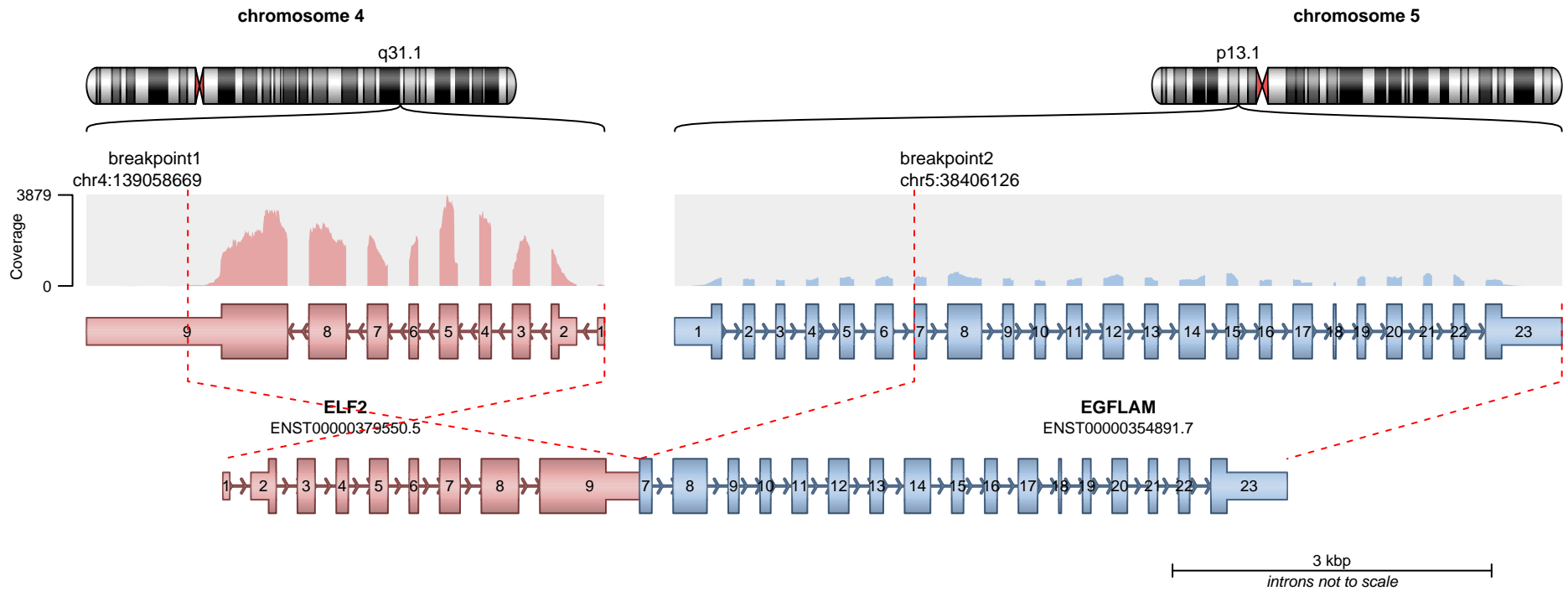

— translocation — deletion
— duplication — inversion

RETAINED PROTEIN DOMAINS
reading frame unclear

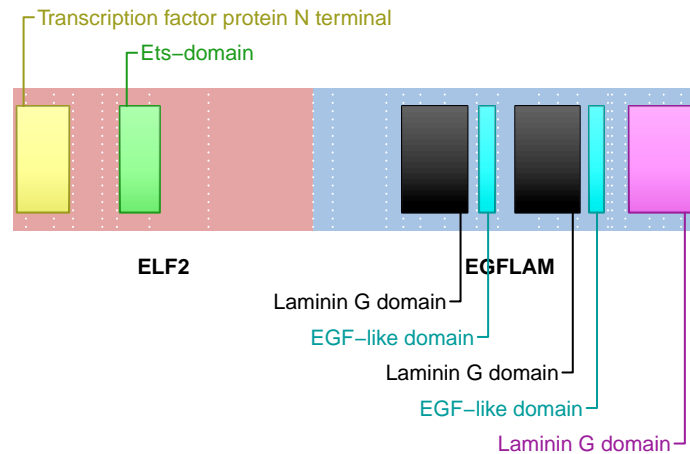

SUPPORTING READ COUNT

Split reads = 14
Discordant mates = 1

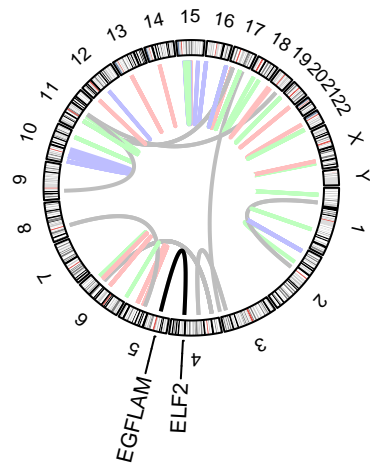
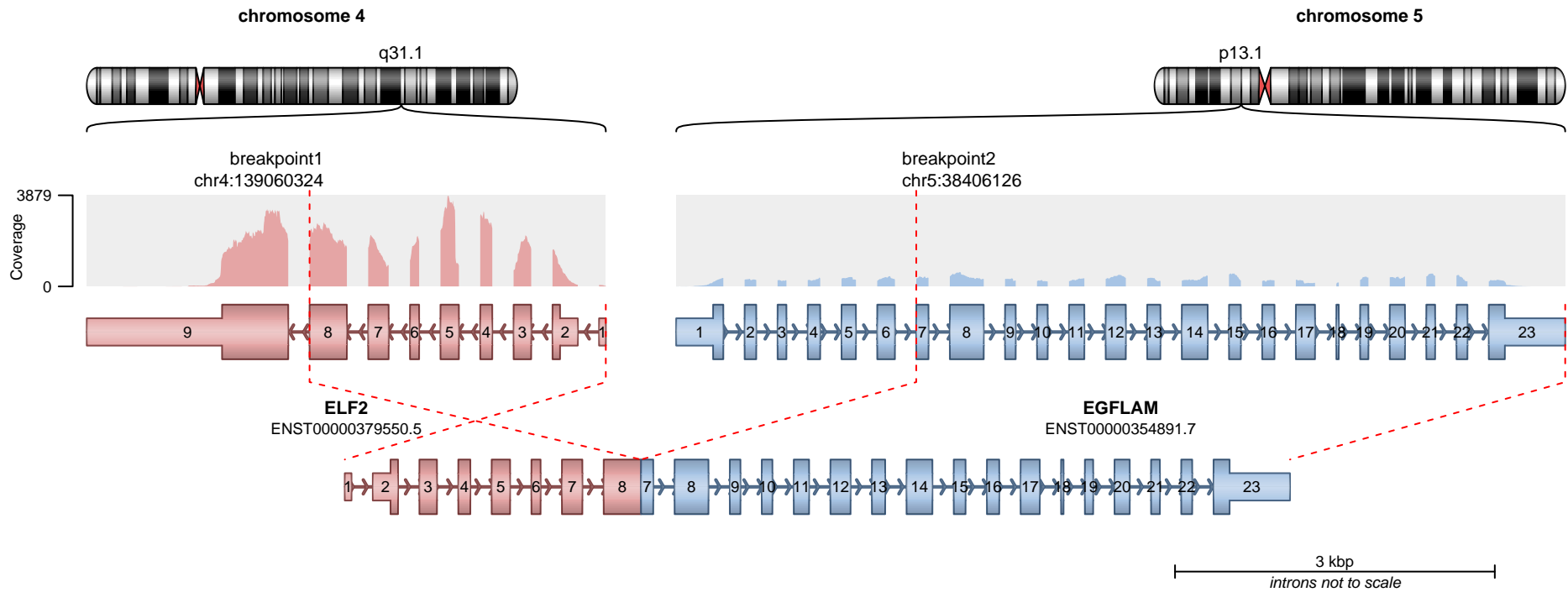

— translocation — deletion
— duplication — inversion

RETAINED PROTEIN DOMAINS
reading frame unclear

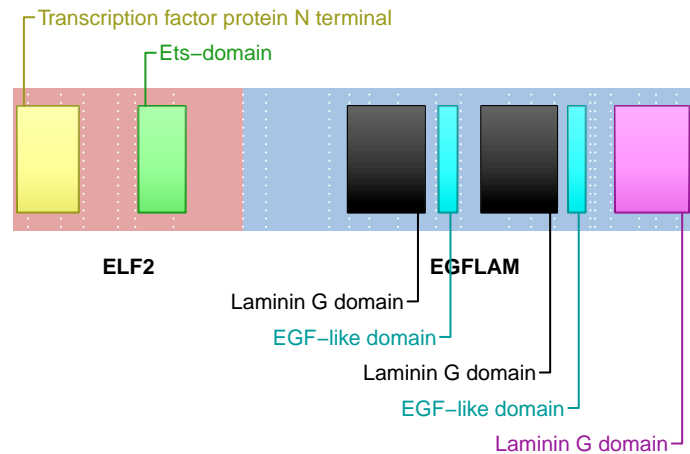

SUPPORTING READ COUNT

Split reads = 4
Discordant mates = 0

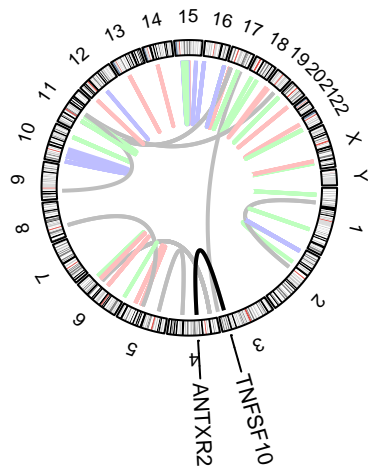
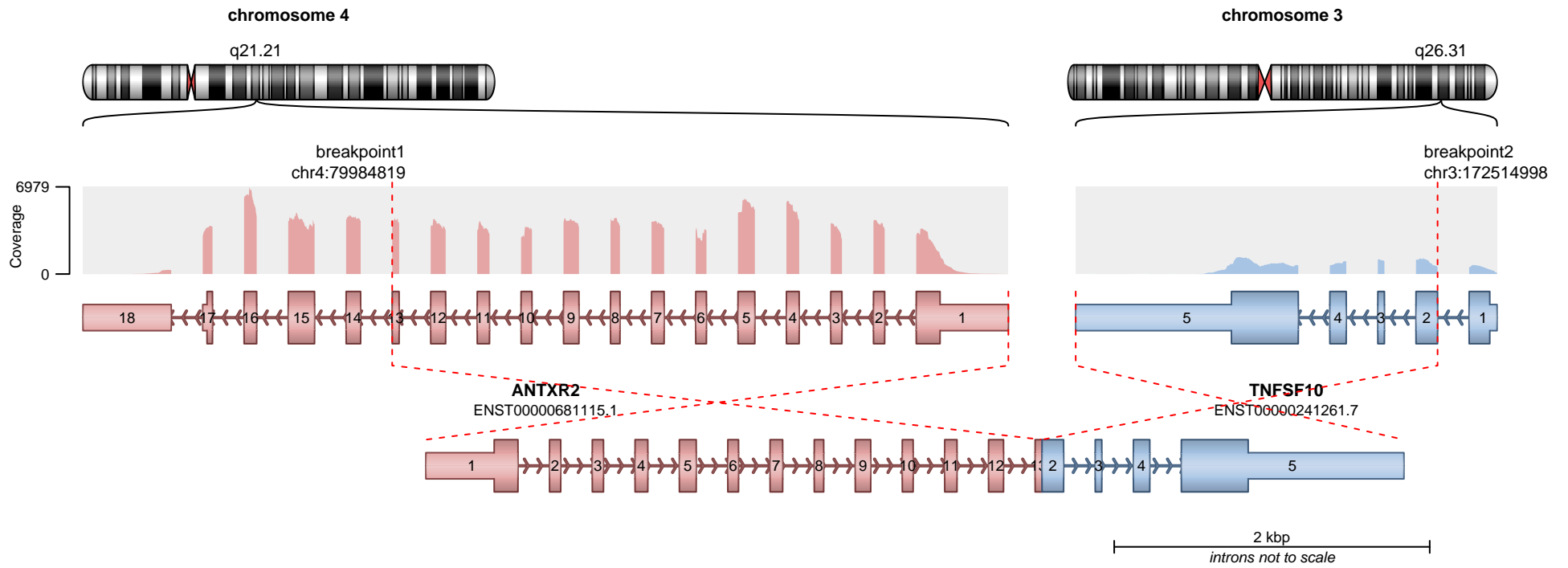

RETAINED PROTEIN DOMAINS
reading frame unclear

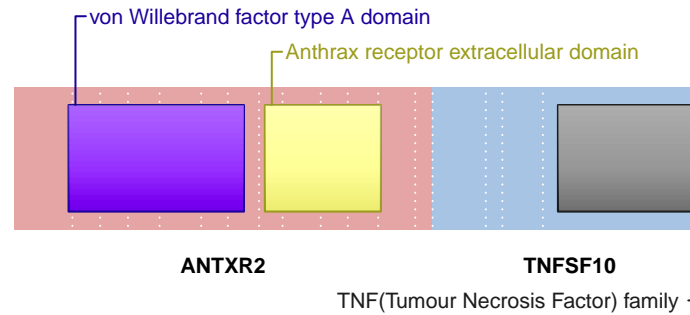

SUPPORTING READ COUNT

Split reads = 13
Discordant mates = 1

— translocation — deletion
— duplication — inversion

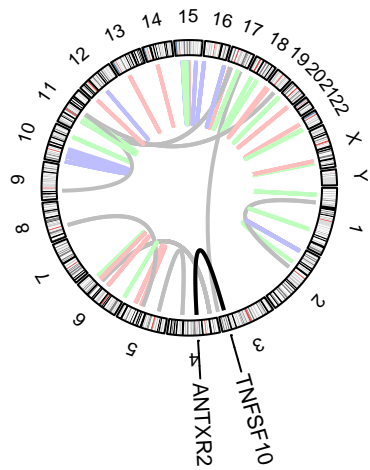
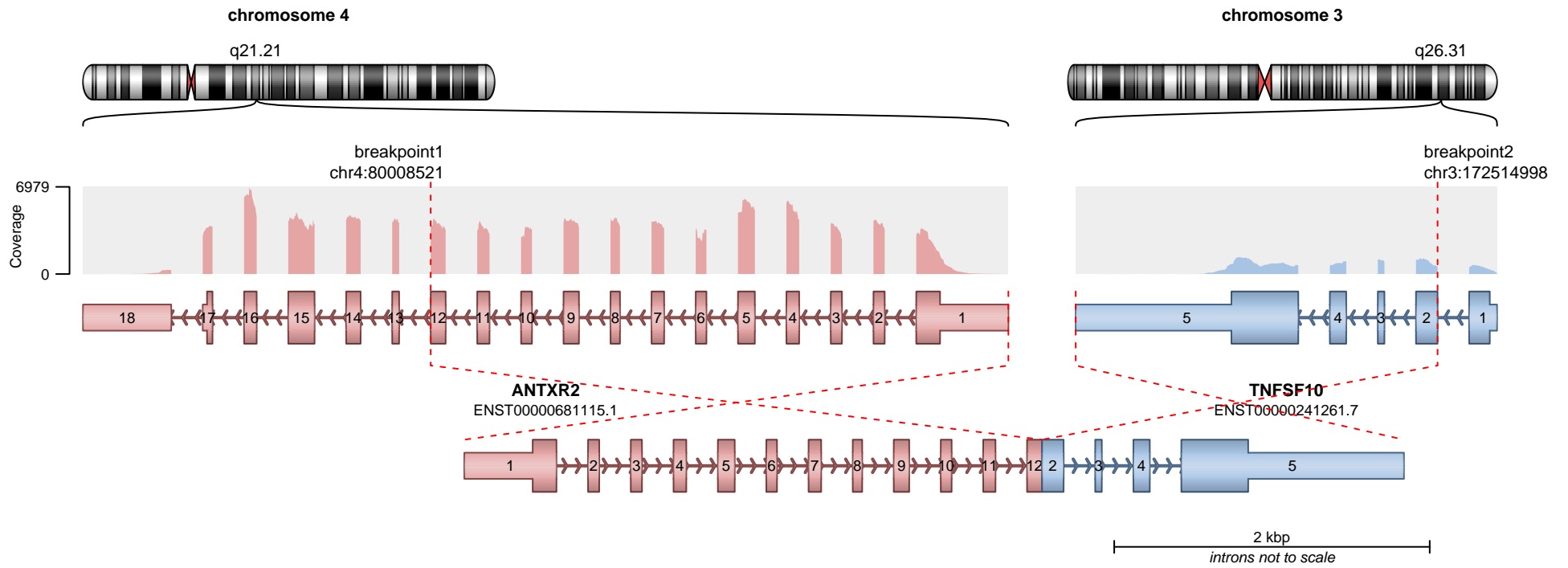

RETAINED PROTEIN DOMAINS
reading frame unclear

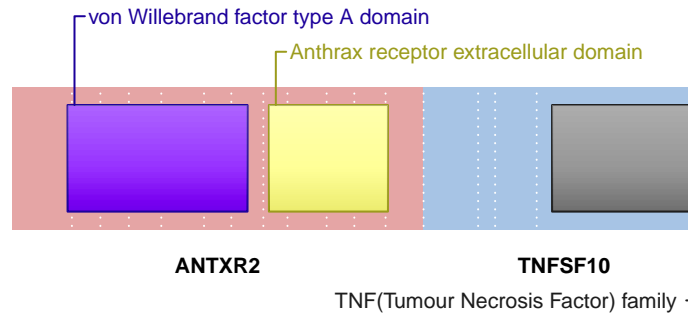

SUPPORTING READ COUNT

Split reads = 2
Discordant mates = 1

— translocation — deletion
— duplication — inversion

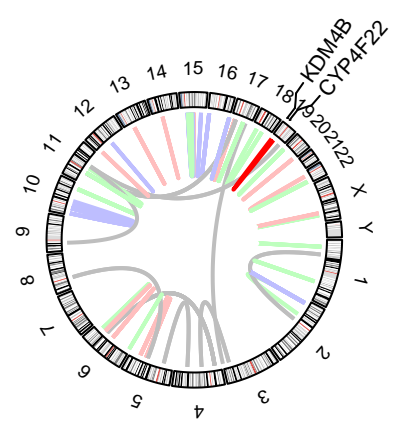
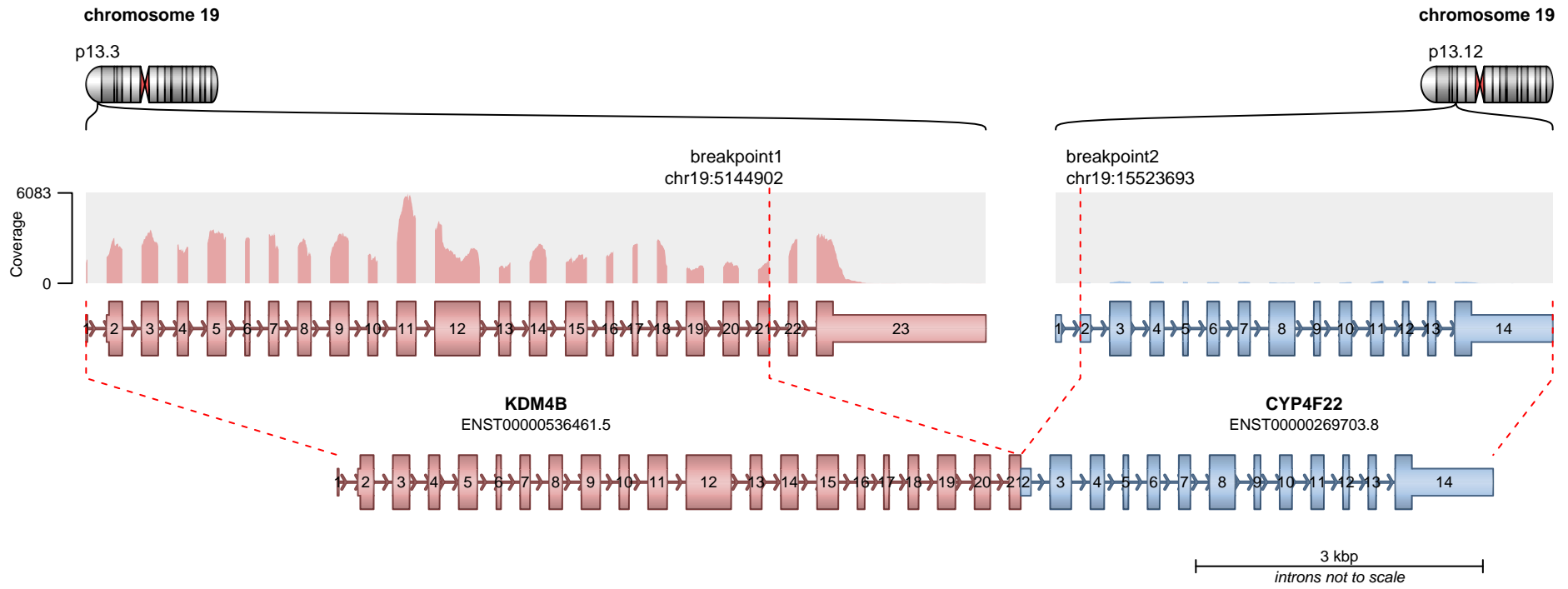

RETAINED PROTEIN DOMAINS
reading frame unclear

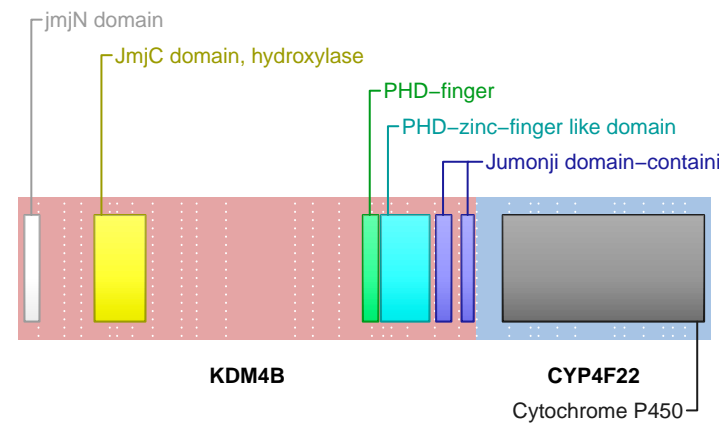

SUPPORTING READ COUNT

Split reads = 13
Discordant mates = 0

- translocation
- duplication
- deletion
- inversion

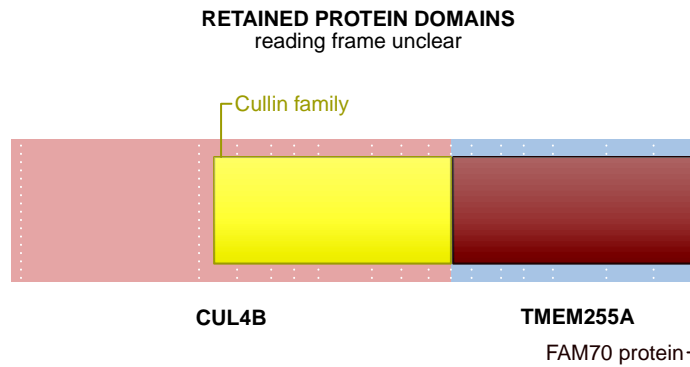
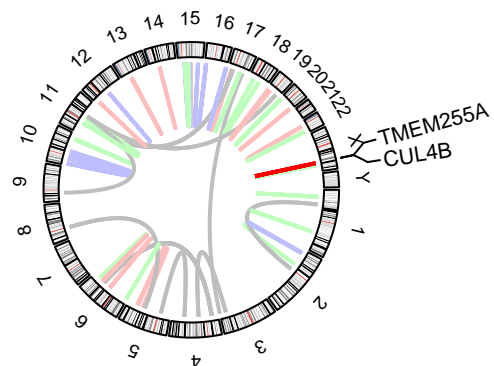
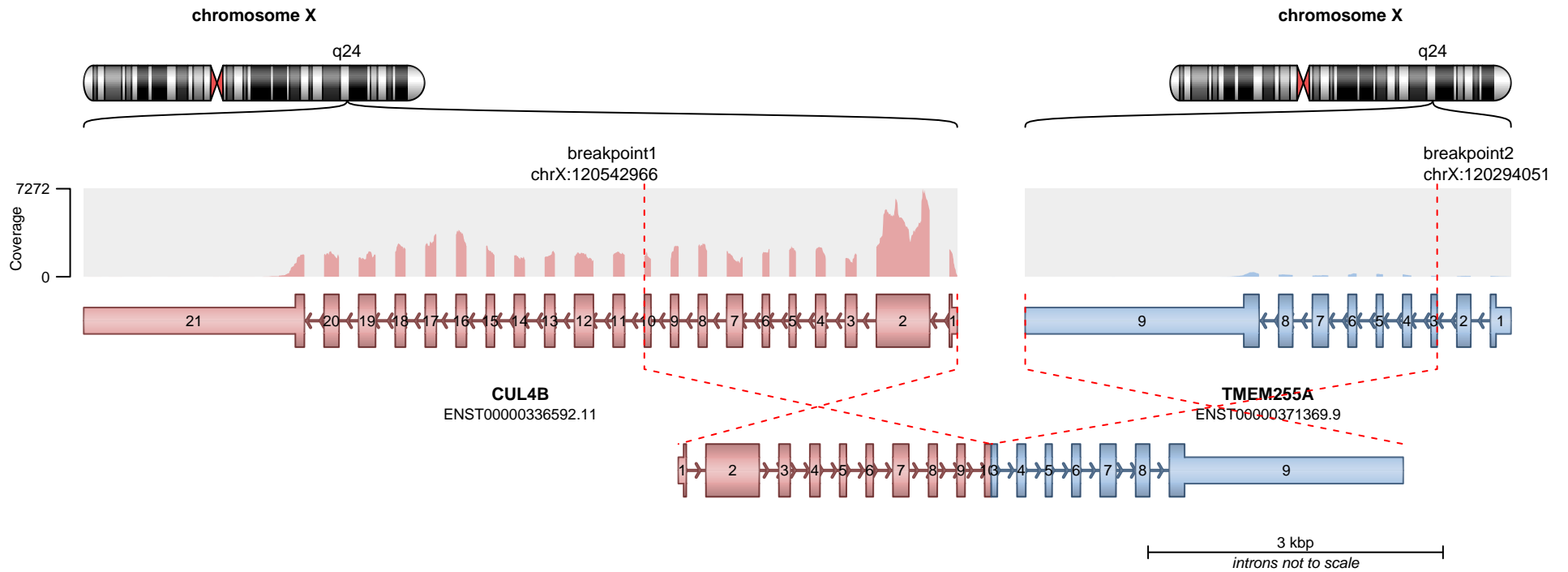

SUPPORTING READ COUNT

Split reads = 12
Discordant mates = 1

— translocation — deletion
— duplication — inversion

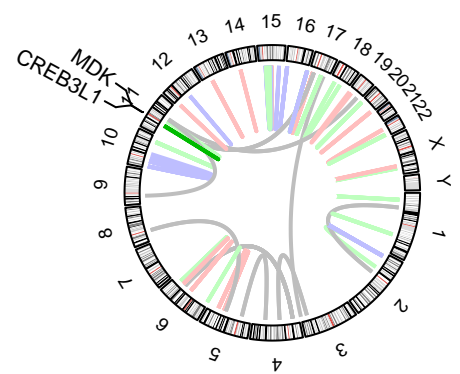
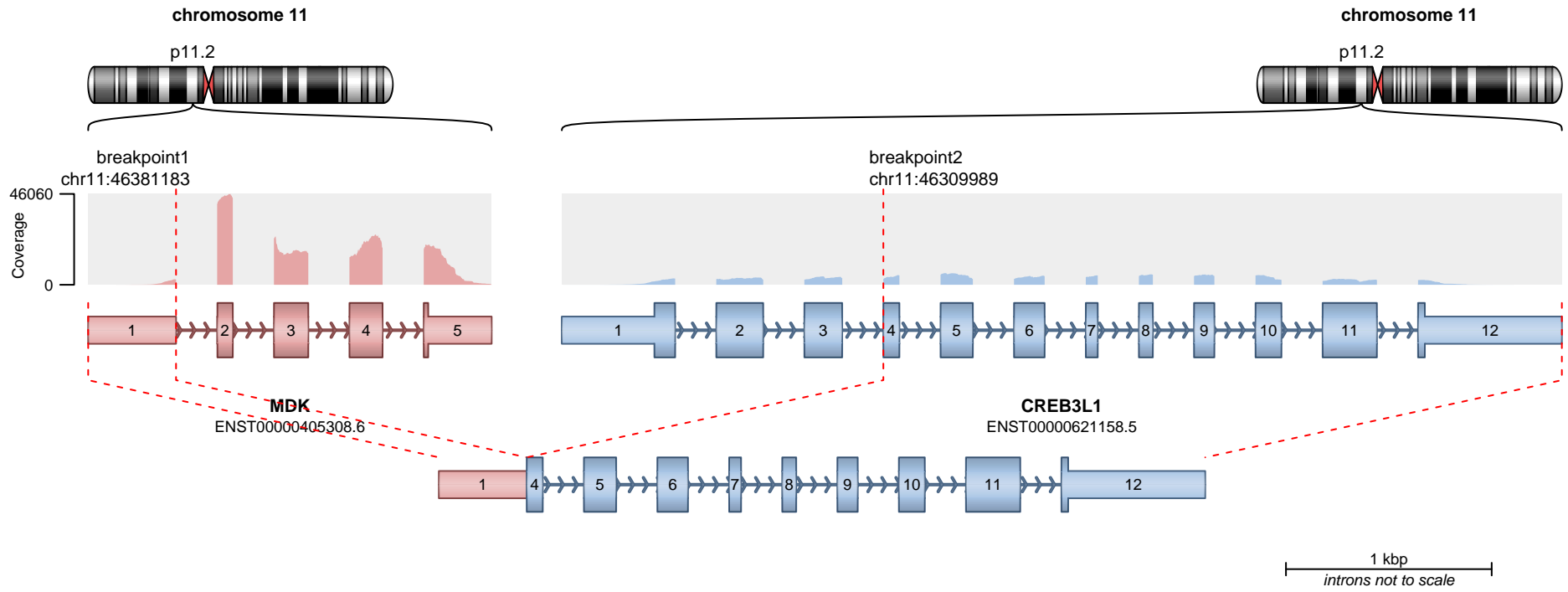

RETAINED PROTEIN DOMAINS
reading frame unclear

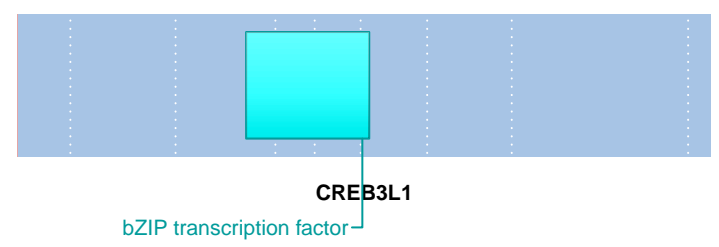

SUPPORTING READ COUNT

Split reads = 11
Discordant mates = 0

— translocation — deletion
— duplication — inversion

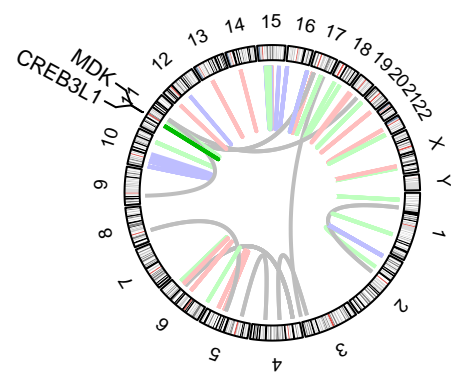
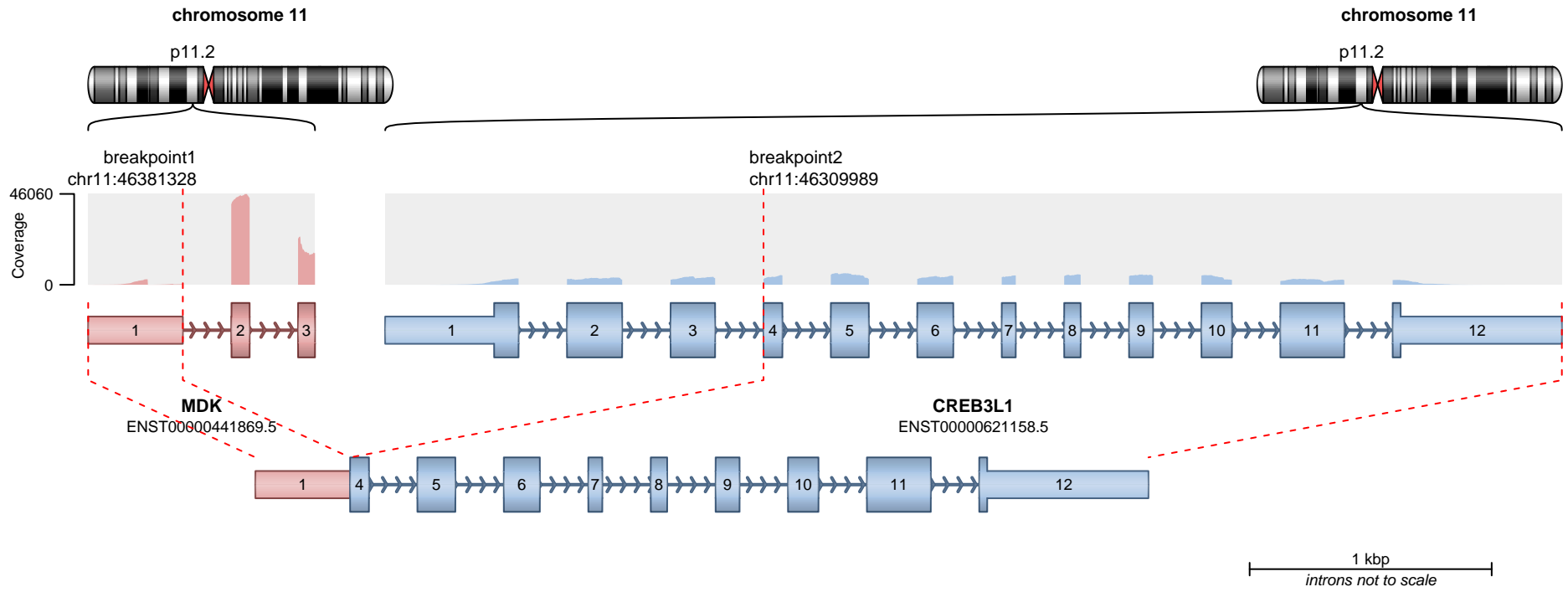

— translocation — deletion
— duplication — inversion

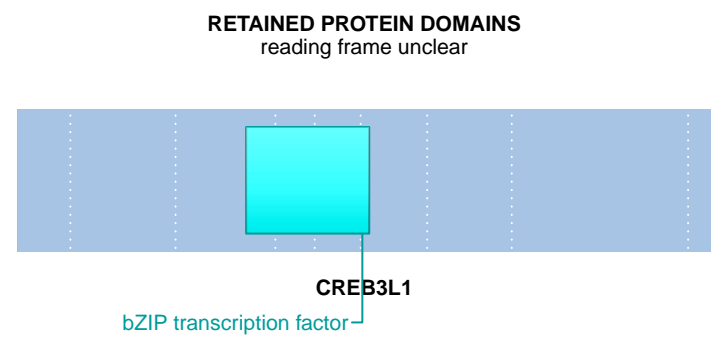

SUPPORTING READ COUNT

Split reads = 2
Discordant mates = 0

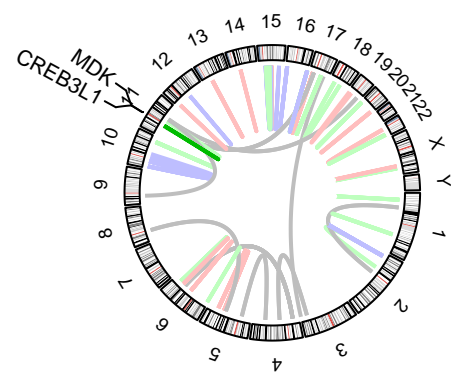
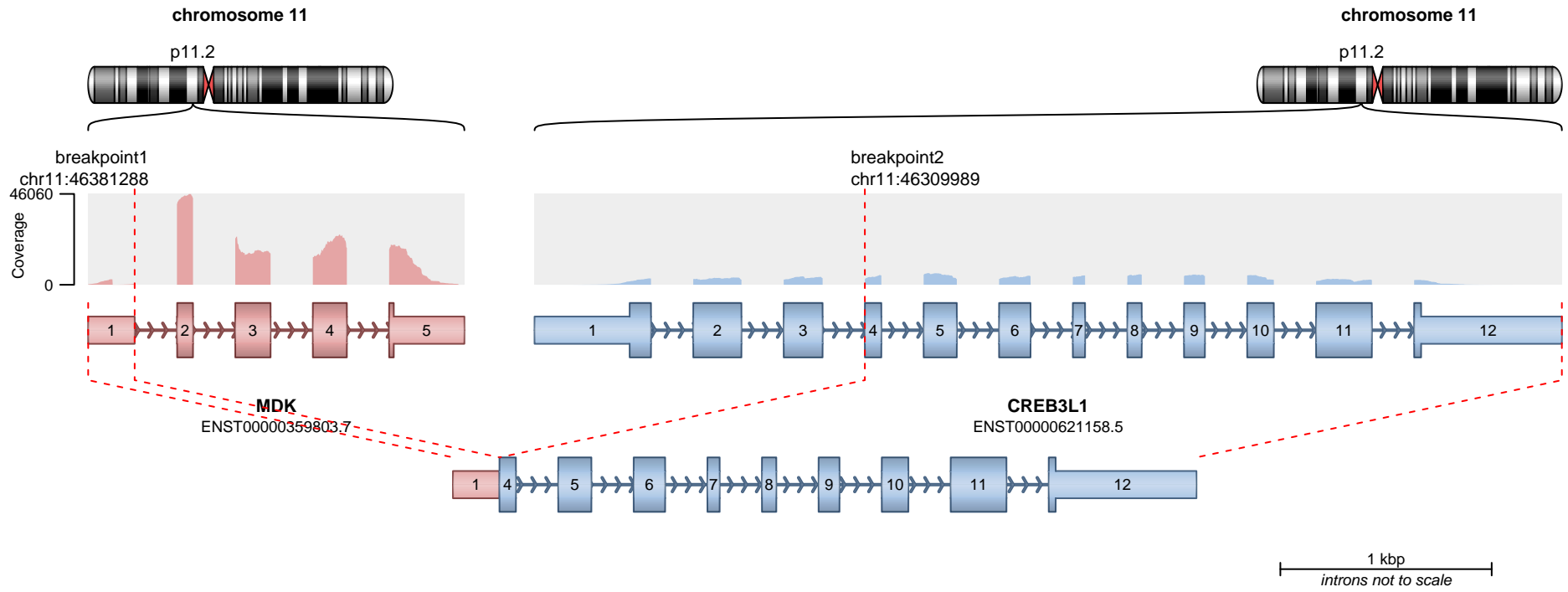

RETAINED PROTEIN DOMAINS
reading frame unclear

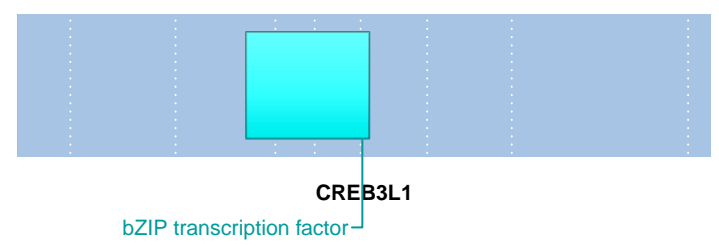

SUPPORTING READ COUNT

Split reads = 1
Discordant mates = 0

— translocation — deletion
— duplication — inversion

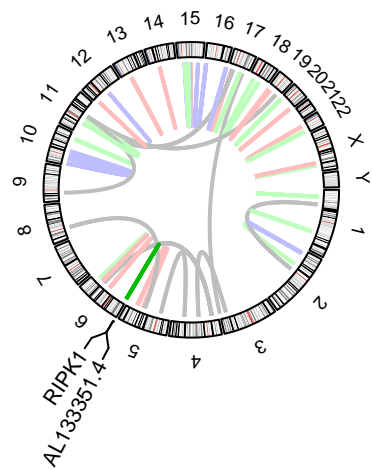
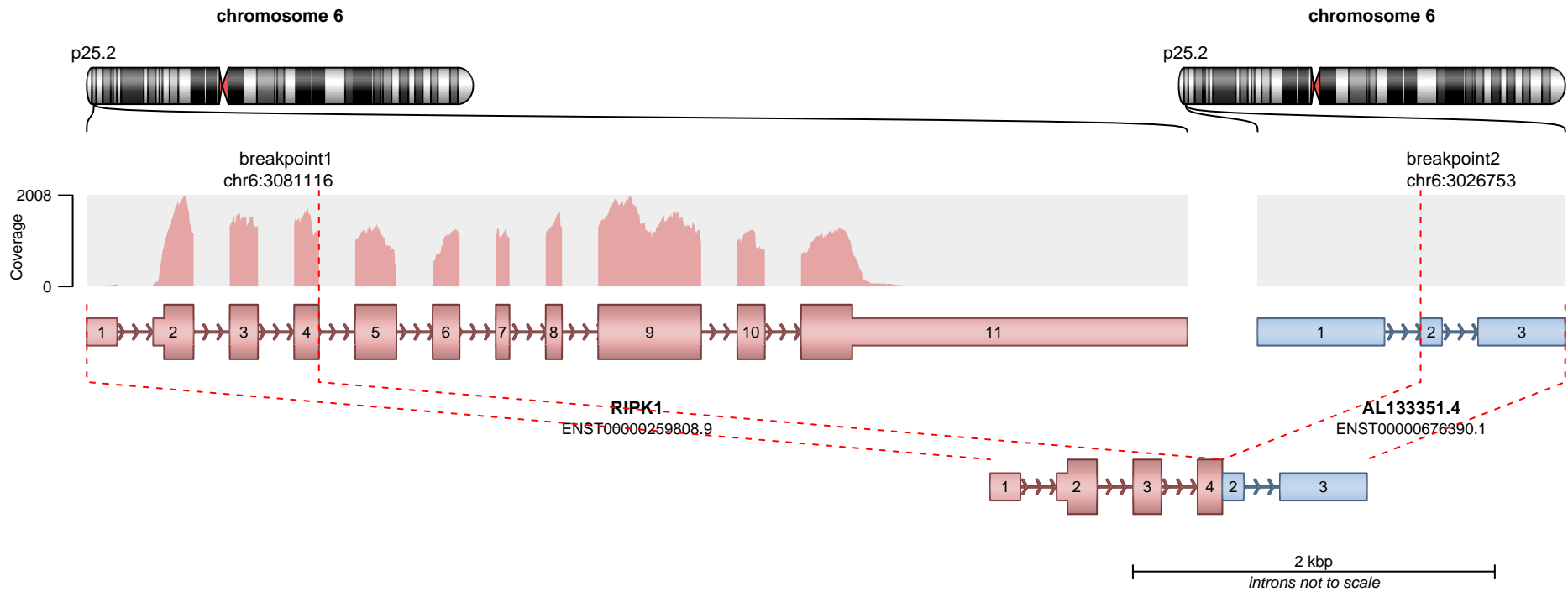

— translocation — deletion
— duplication — inversion

RETAINED PROTEIN DOMAINS
reading frame unclear

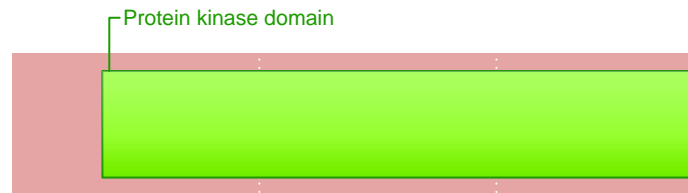

RIPK1

SUPPORTING READ COUNT

Split reads = 6
Discordant mates = 1

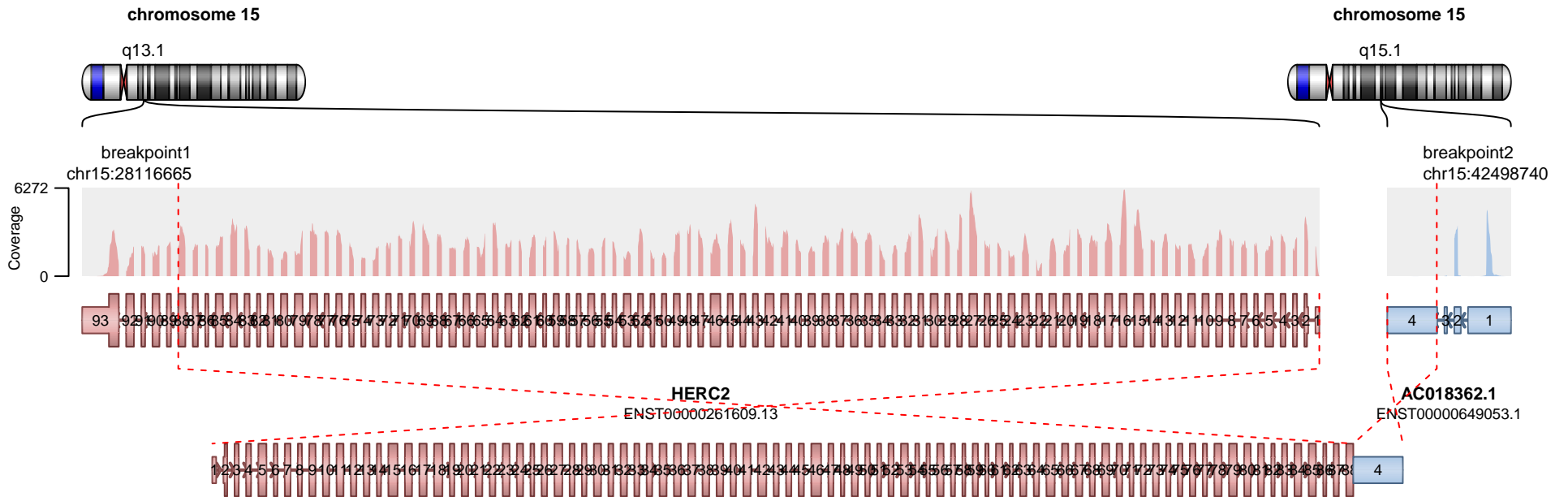

RETAINED PROTEIN DOMAINS
reading frame unclear

7 kbp
introns not to scale

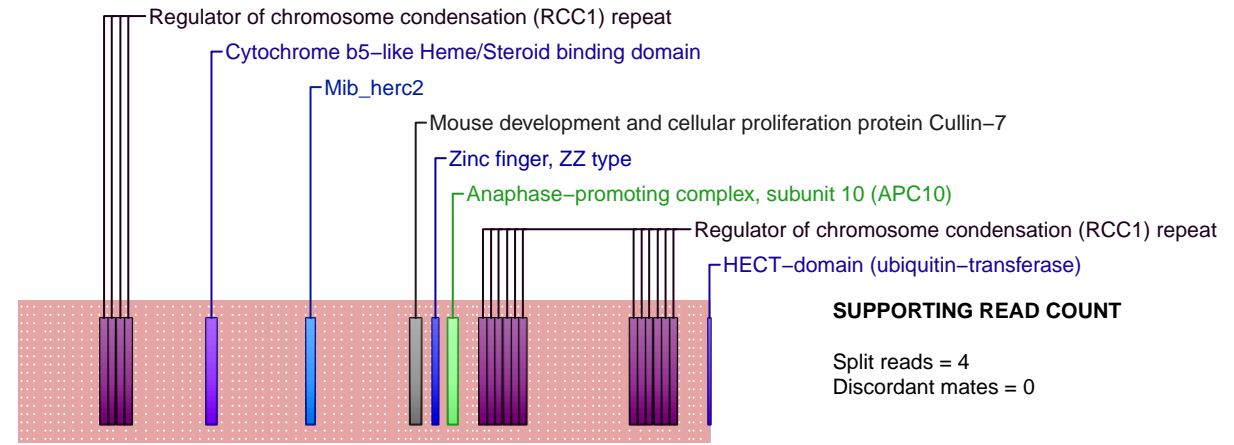
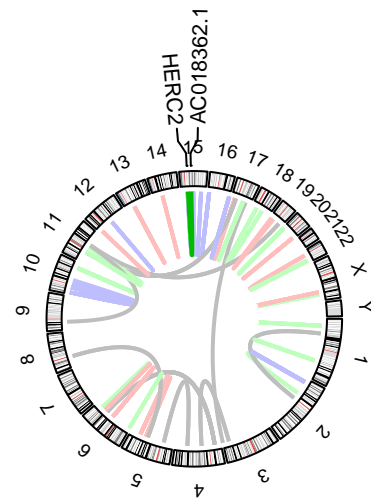

SUPPORTING READ COUNT

Split reads = 4
Discordant mates = 0

HERC2

— translocation — deletion
— duplication — inversion

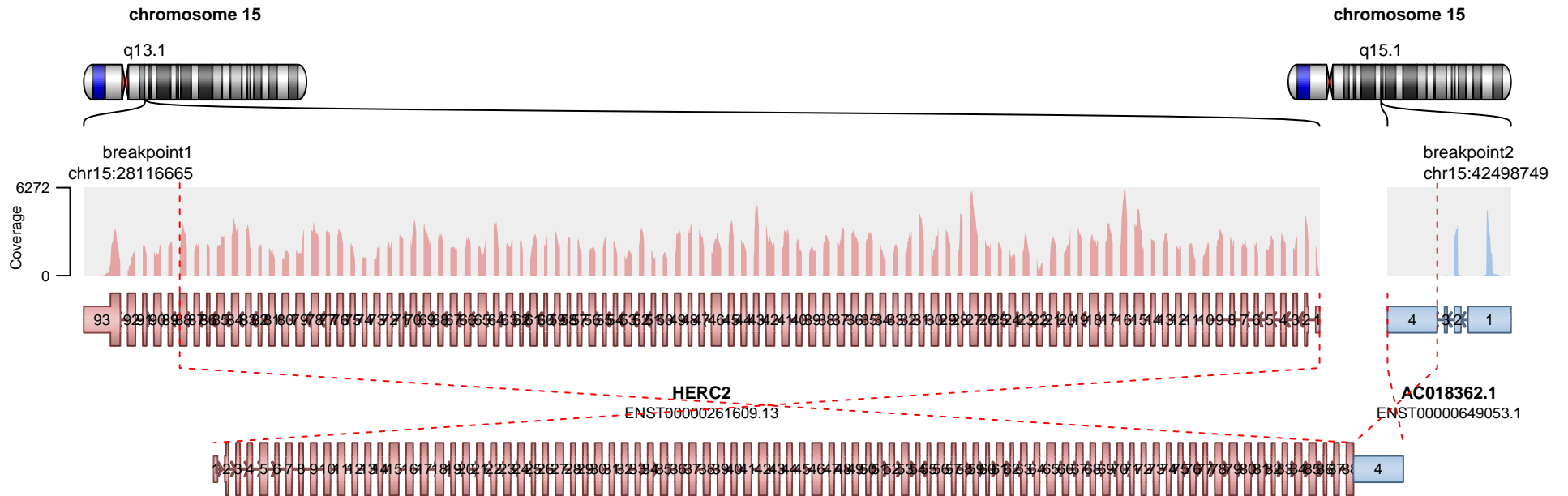

RETAINED PROTEIN DOMAINS
reading frame unclear

7 kbp
introns not to scale

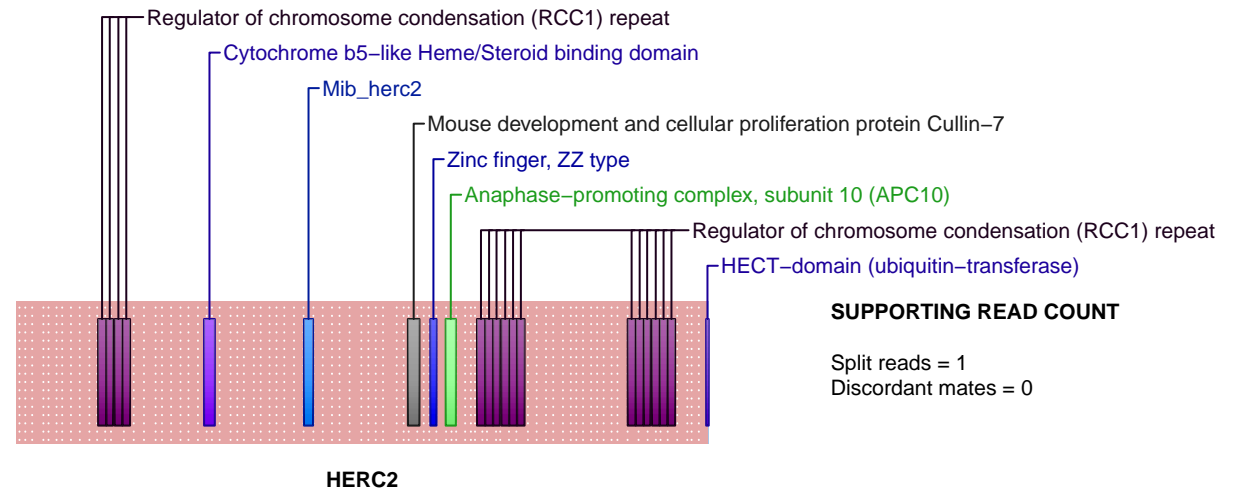
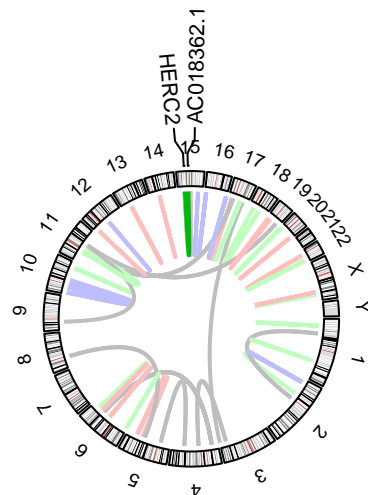

— translocation — deletion
— duplication — inversion